

- F NOTICE DE MONTAGE (NICHE)
- GB INSTALLATION INSTRUCTIONS (RECESS)
- E MANUAL DE INSTALACION (EMPOTRADO)
- I ISTRUZIONI DI MONTAGGIO (INCASSO)
- NL INSTALLATIE VOORSCHRIFTEN (INGEBOUWD)
- D INSTALLATIONSANLEITUNG (NISCHENAUSFÜHRUNG)

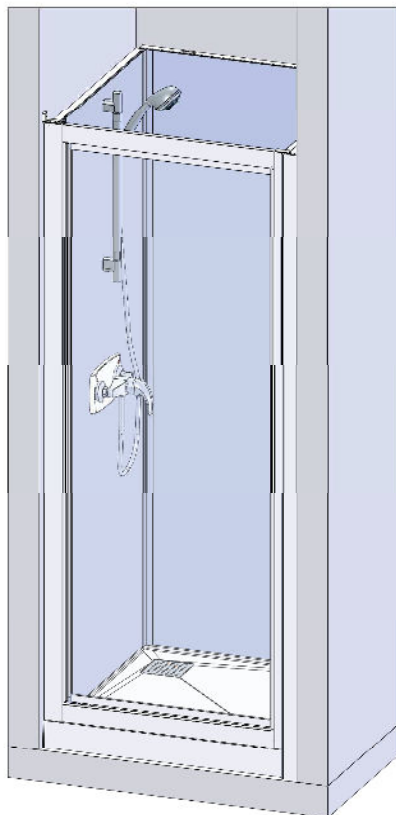

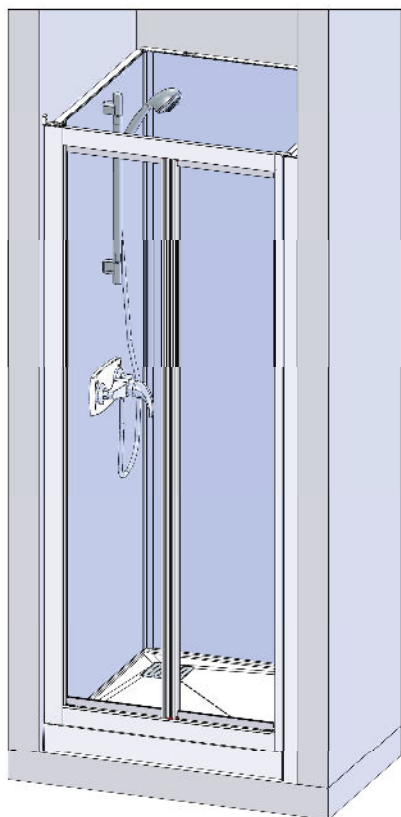
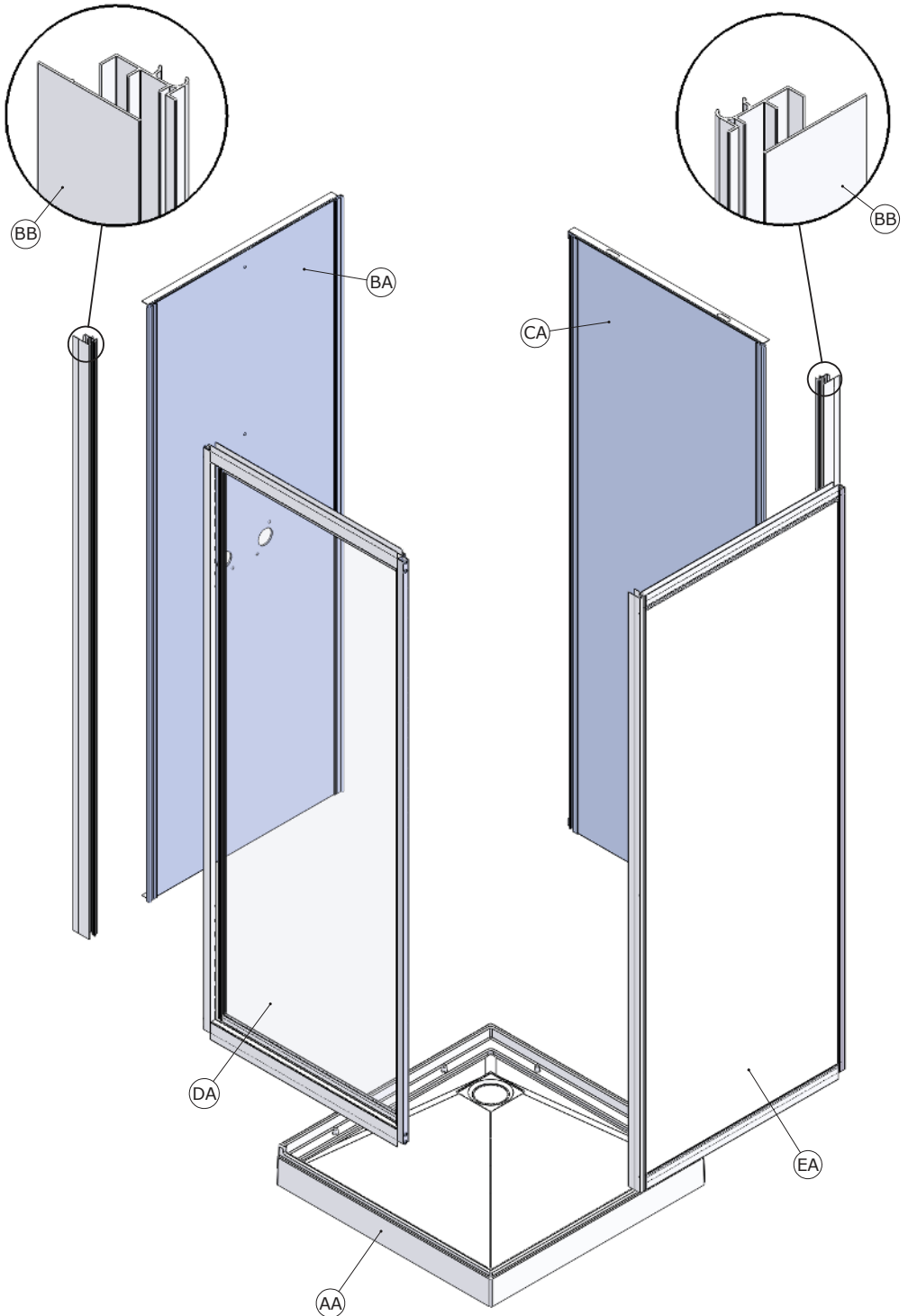

**PIECES DETACHEES - SPARE PARTS - PIEZAS DE REPUESTO
PEZZI DI RICAMBIO - ONDERDELEN - ERSATZTEILE**

Rep	70 x 70		80 x 80		90 x 90		100 x 80		Qté
	BAS/LOW	HAUT/HIGH	BAS/LOW	HAUT/HIGH	BAS/LOW	HAUT/HIGH	BAS/LOW	HAUT/HIGH	

COLIS 1

AA	REC417	REC423	REC418	REC424	REC419	REC425	REC420	REC426	1
AB	BOND14								1
AC	TOL54								1
AD	TUY62								1
AE	MOU08								1

COLIS 2

BA	CP367	CP369	CP371	CP369	1
BB	5003				2
BC	PPL776				2
BD	VIS41				2
BE	PPL775				2
BF	EQU68				2
BG	CHE02				2
BH	VIS 3,5x25				8
BK	PPL735				1
BL	PPL736				1

COLIS 3

CA	CP366	CP368	CP370	CP372	1
----	-------	-------	-------	-------	---

COLIS 4

DA	1P	C8360	C8361	C8362	C8363	1
	2P	C11122	C11123	C11124	C11121	1
DB	JOI235				1	
DC	JOI287				2	

COLIS 5

EA	C8376	C8377	C8378	C8377	1
EB	PPL739				1
EC	PPL740				1

COLIS 6

FA	63mm	PUS63	1
	95mm	PUS64	1
	127mm	PUS65	1
FB	4199		1
FC	4197		1
FE	RON34		3
FF	RON05		5
FG	CHE02		3
FH	VIS17		3
FI	VIS117		5

BOITE

GA	Mitigeur MECA	SET50	1
	Mitigeur THERMO <td>SET51</td> <td>1</td>	SET51	1
GB	TUY60		1
GC	TUY61		1
GD	ECR77		6
GE	VIS200		6
GF	CAP18		4
GG	KIT109		1

Colis 1 - Parcel 1 - Paquete 1
 Pacchetto 1 - Verpakking 1 - Paket 1

S1552

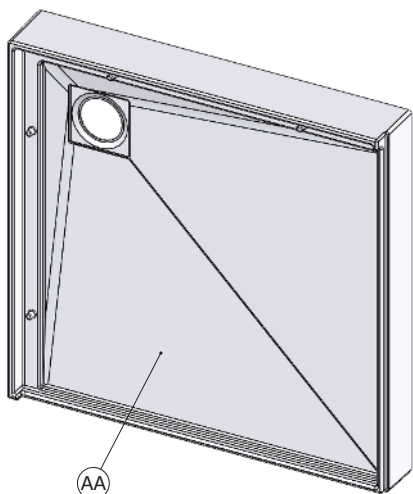

+

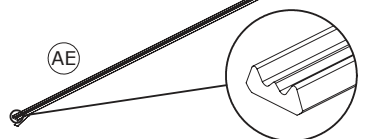
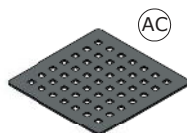
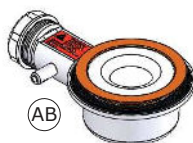

Colis 2 - Parcel 2 - Paquete 2
 Pacchetto 2 - Verpakking 2 - Paket 2

S1555

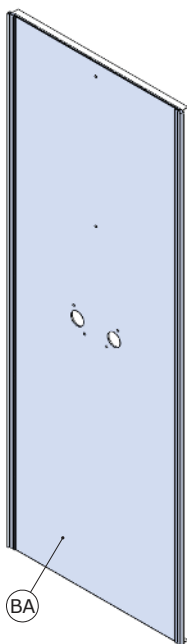

+



+

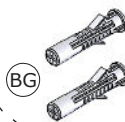
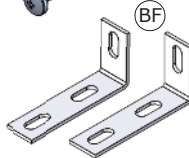
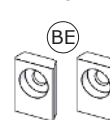

X8

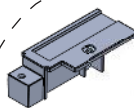

BK

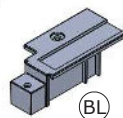

BL

- F Colis 3
- GB Parcel 3
- E Paquete 3
- I Pacchetto 3
- NL Verpakking 3
- D Paket 3

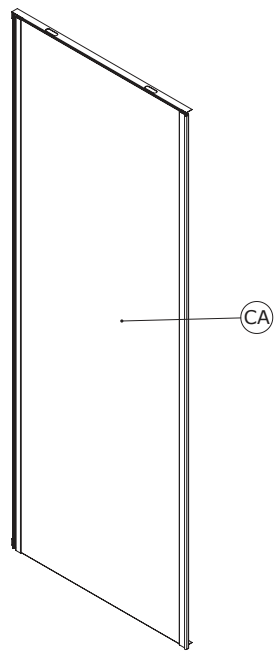

- F Colis 4
- GB Parcel 4
- E Paquete 4
- I Pacchetto 4
- NL Verpakking 4
- D Paket 4

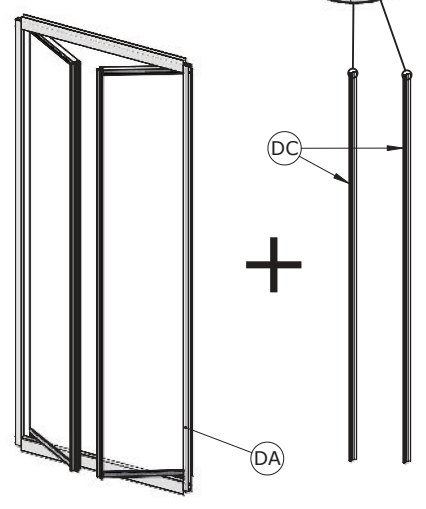
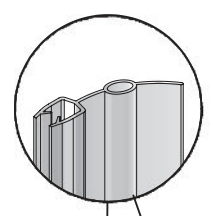
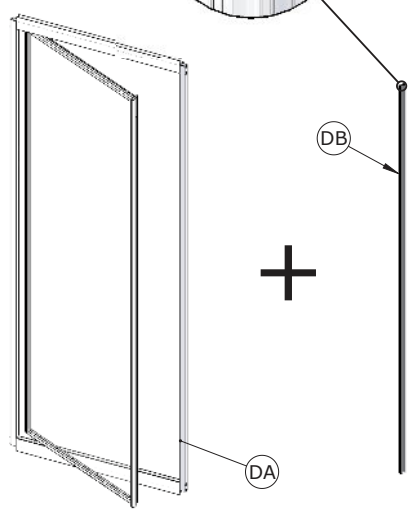
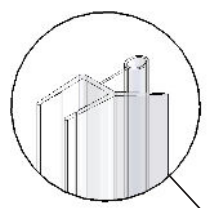

- F Colis 5 GB Parcel 5
 E Paquete 5 I Pacchetto 5
 NL Verpakking 5 D Paket 5

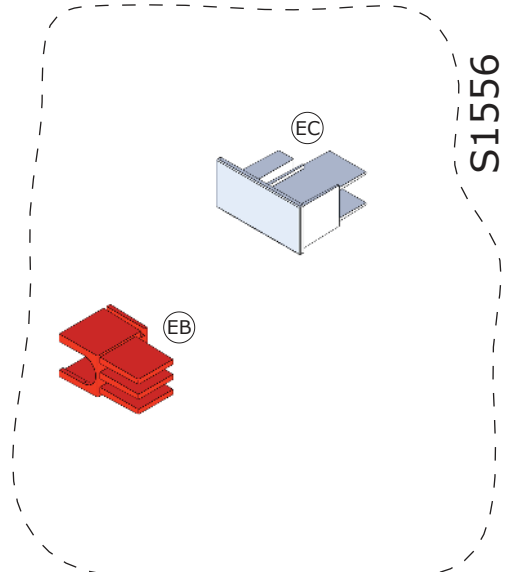
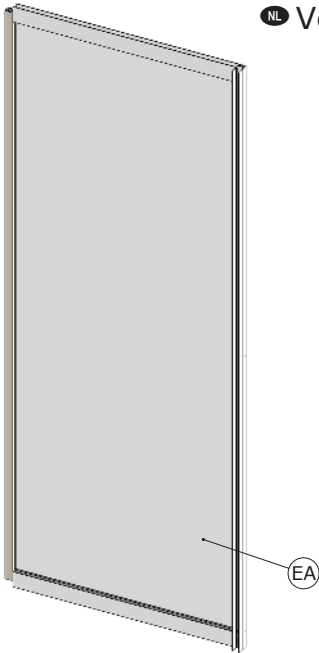

- F Colis 6 GB Parcel 6

- E Paquete 6 I Pacchetto 6
 NL Verpakking 6 D Paket 6

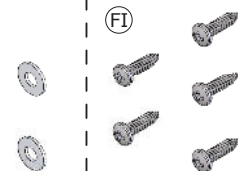
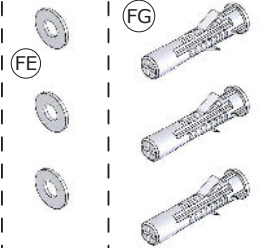
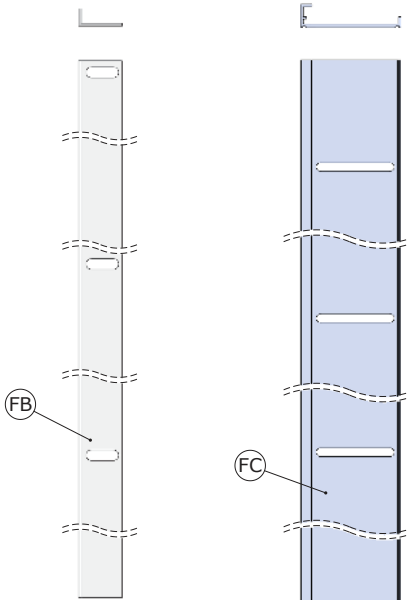
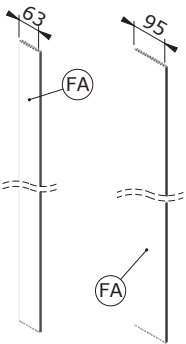

F Boite GB Box E Caja
 I Scatola NL Doos D Kiste

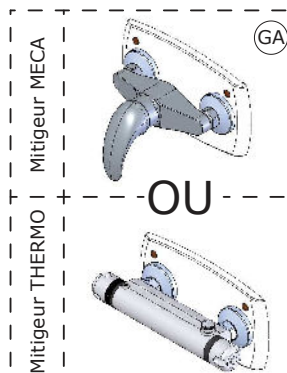
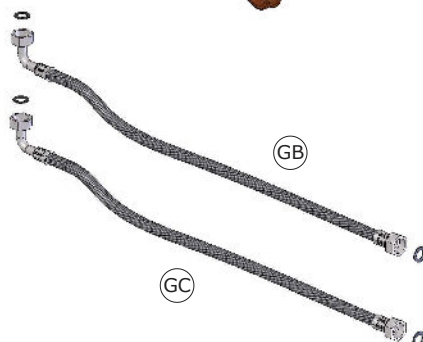
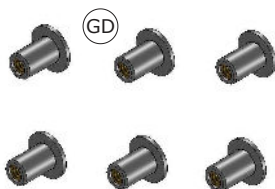

Matériel nécessaire - Tools required - Herramientas necesarias
Materiale necessario - Benodigd gereedschap - Werkzeuge erforderlich

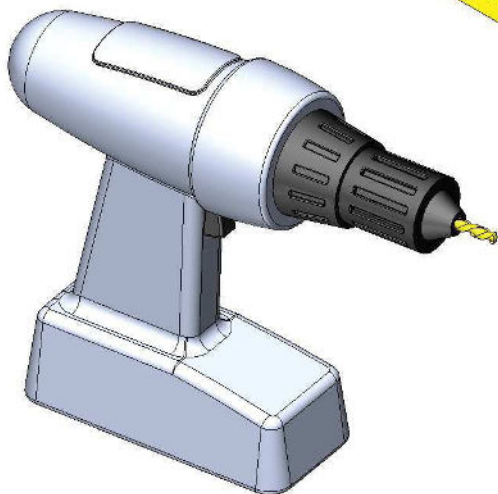
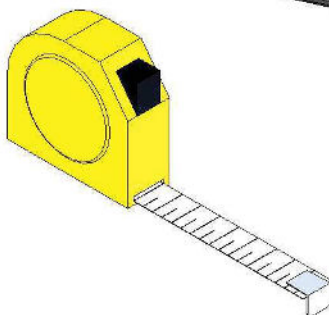
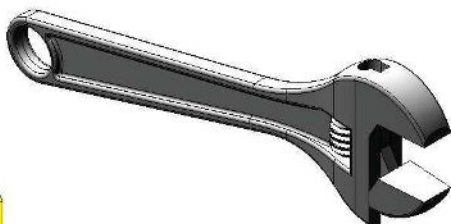
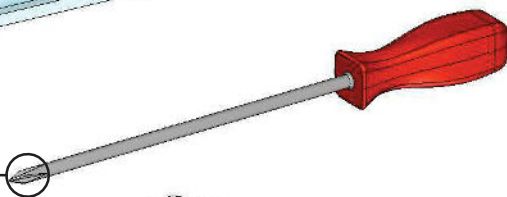
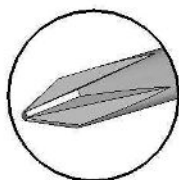
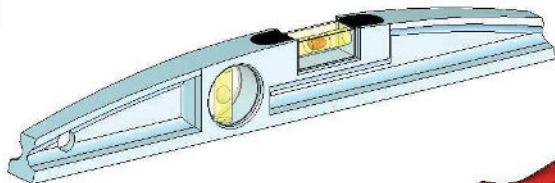
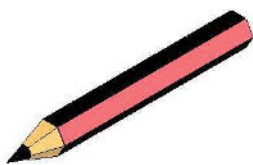

Ø 3 mm



Ø 6 mm



Ø 8 mm



● REVERSIBILITE ● REVERSIBILITY ● REVERSIBILIDAD
 ● REVERSIBILITA ● OMKEERBAARHEID ● WAHLWEISE MONTAGE

● MONTAGE A GAUCHE
 ● LEFT HAND
 ● MONTAJE A LA IZQUIERDA
 ● MONTAGGIO A SINISTRA
 ● MONTAGE LINKS
 ● MONTAGE LINKS

● MONTAGE A DROITE
 ● RIGHT HAND
 ● MONTAJE A LA DERECHA
 ● MONTAGGIO A DESTRA
 ● MONTAGE RECHTS
 ● MONTAGE RECHTS

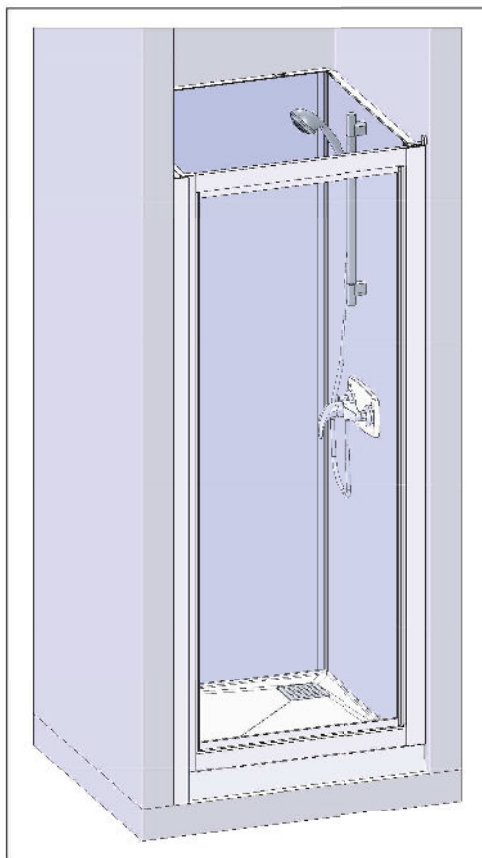
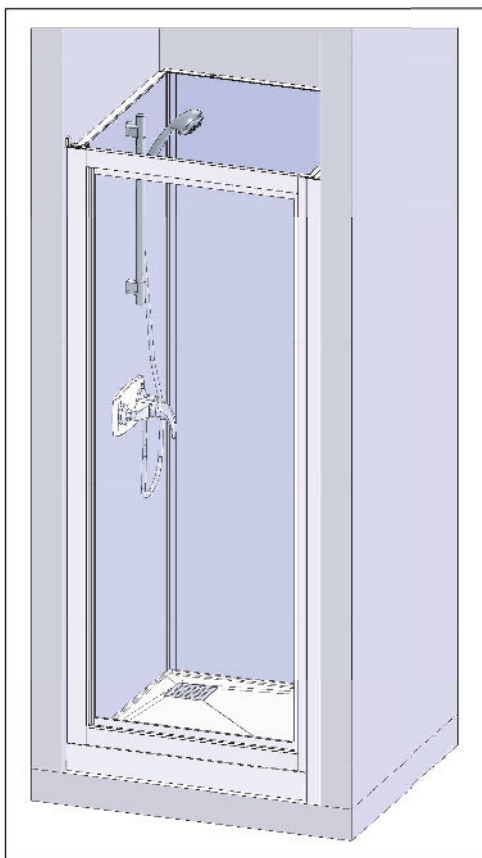

● Vous avez la possibilité de réaliser un montage à droite ou un montage à gauche. Notre notice d'installation décrit un montage à gauche. Si vous voulez réaliser un montage à droite, il vous suffit d'inverser le montage.

● This cubicle can be installed either left or right hand. These installation instructions show a left hand installation.

● Puede realizar un montaje a la derecha o un montaje a la izquierda. Nuestro folleto de instalación describe un montaje a la izquierda. Si desea montar su cabina a la derecha sólo tendrá que realizar el montaje al contrario.

● Avete la possibilità di effettuare il montaggio a destra o a sinistra. Il nostro manuale descrive il montaggio a sinistra. Se volete realizzare il montaggio a destra è sufficiente invertire varie fasi di montaggio.

● U kunt de douche cabine rechts of links monteren. Onze handleiding beschrijft de links montage van de cabine. Keer de montage om als u de cabine rechts wilt monteren.

● Sie haben die Möglichkeit, eine Montage auf der linken Seite oder eine Montage auf der rechten Seite durchzuführen. Unsere Montageanleitung beschreibt eine Montage auf der linken Seite. Wenn Sie die Montage lieber auf der rechten Seite durchführen wollen, müssen Sie nur den Montageprozess umkehren.

①

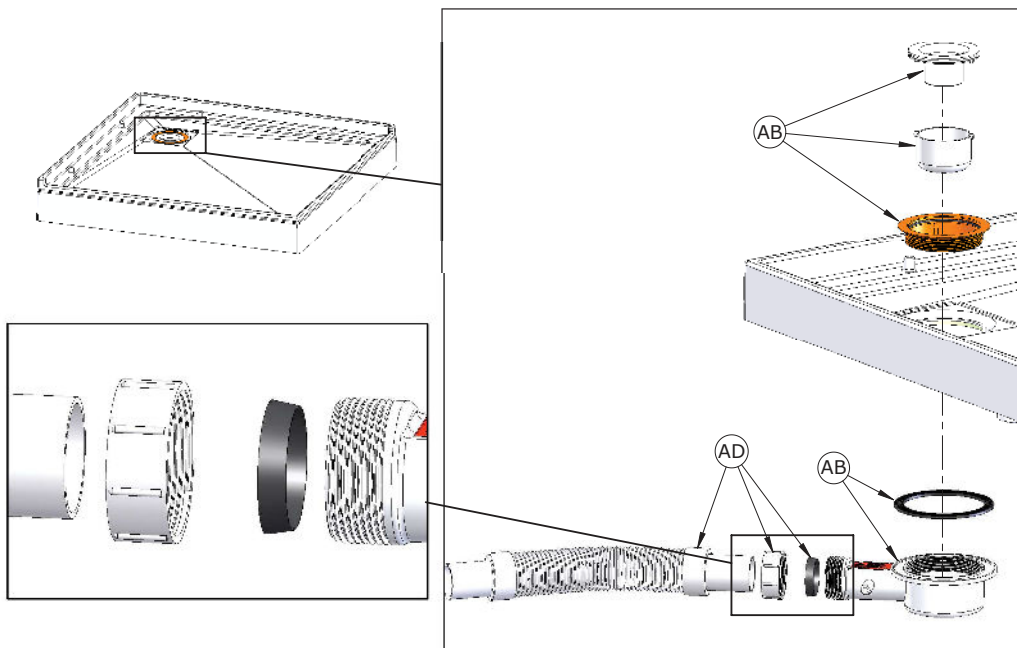

②

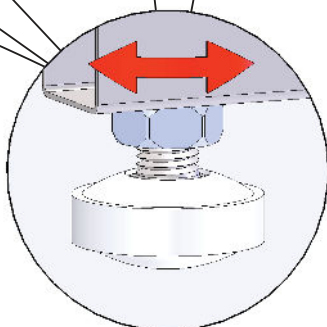
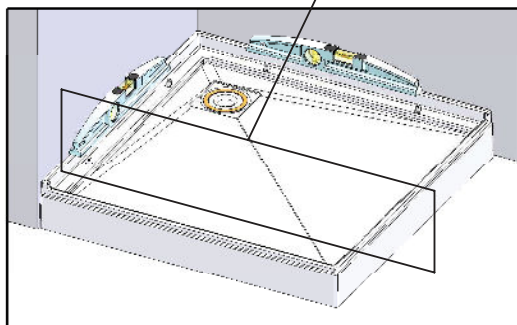
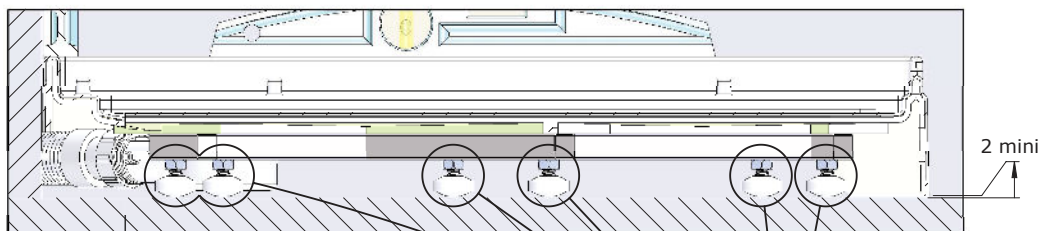

- Pieds en contact avec le sol.
- Feet in contact with the ground.
- Pies en contacto con el suelo.
- Piedi a contatto con il terreno.
- Voeten in contact met de grond.
- Sockelfüße im Kontakt mit dem Boden.

03

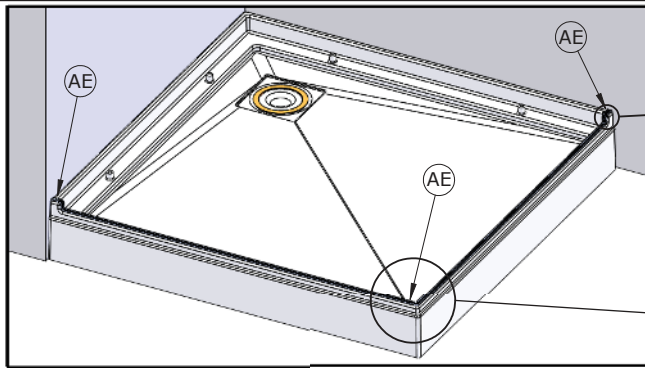

OU
OR
O
OF
ODER

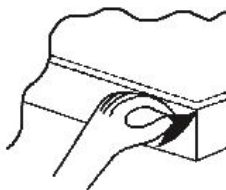
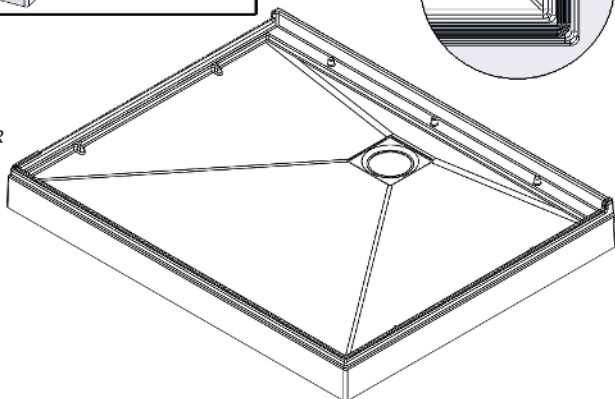
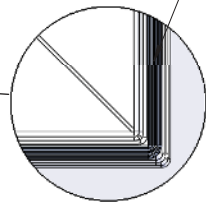
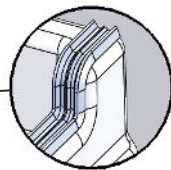

04

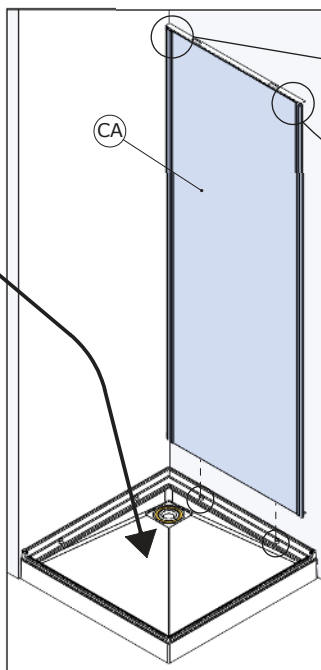

Protéger le receveur
Protect the shower tray
Protegere il piatto
Scherm de douchebak
Duschtaße schützen

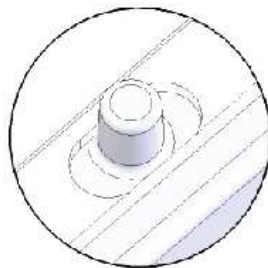
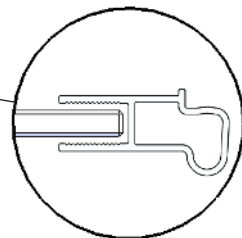
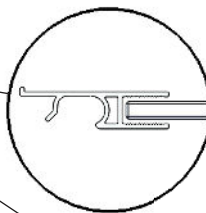

05

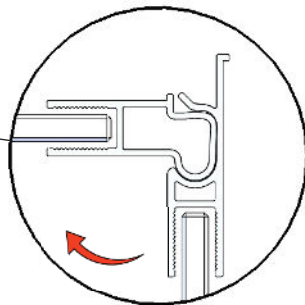
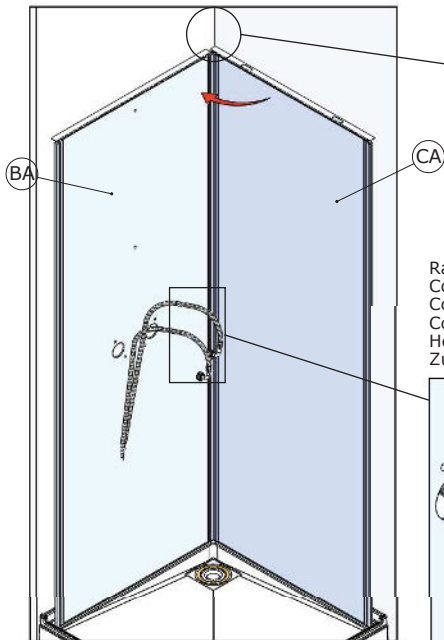

Raccorder l'arrivée d'eau et la liaison équipotentielle.
 Connecting the water inlet and the equipotential link.
 Collegare l'ingresso dell'acqua e il collegamento equipotenziale.
 Conexión de la entrada de agua y la conexión equipotencial.
 Het aansluiten van de watertoevoer en de equipotentiaalverbinding.
 Zufluss und Potenzialausgleich anschließen.

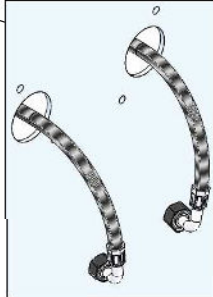

Passer vos flexibles d'alimentation dans les ouvertures prévues.
 Pass your supply hoses in the planned openings.
 Pase los flexibles de alimentación en las aperturas previstas.
 Passate i tubi flessibili di alimentazione nelle aperture previste.
 Geven de flexibele leidingen van voedsel in de voorziene openingen.
 Zulaufschläuche durch die vorgesehenen Öffnungen führen.

06

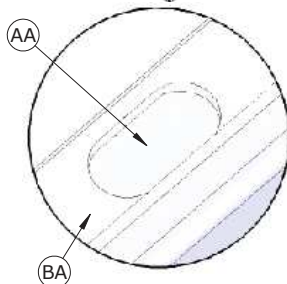
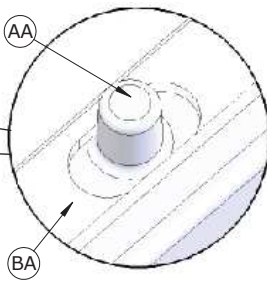
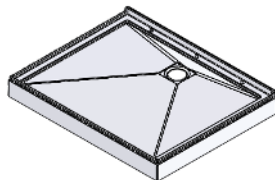
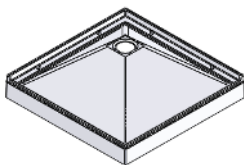
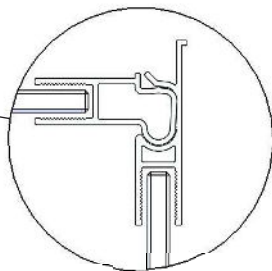
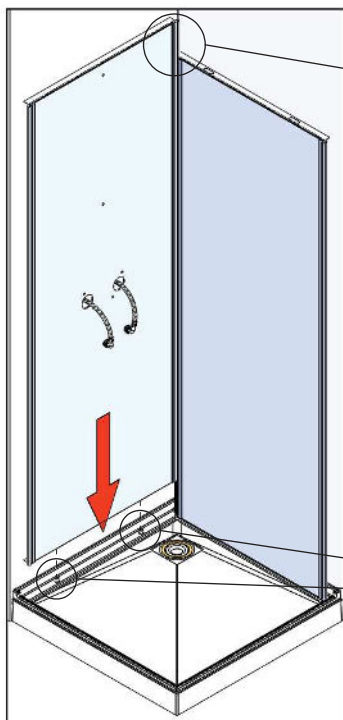

07

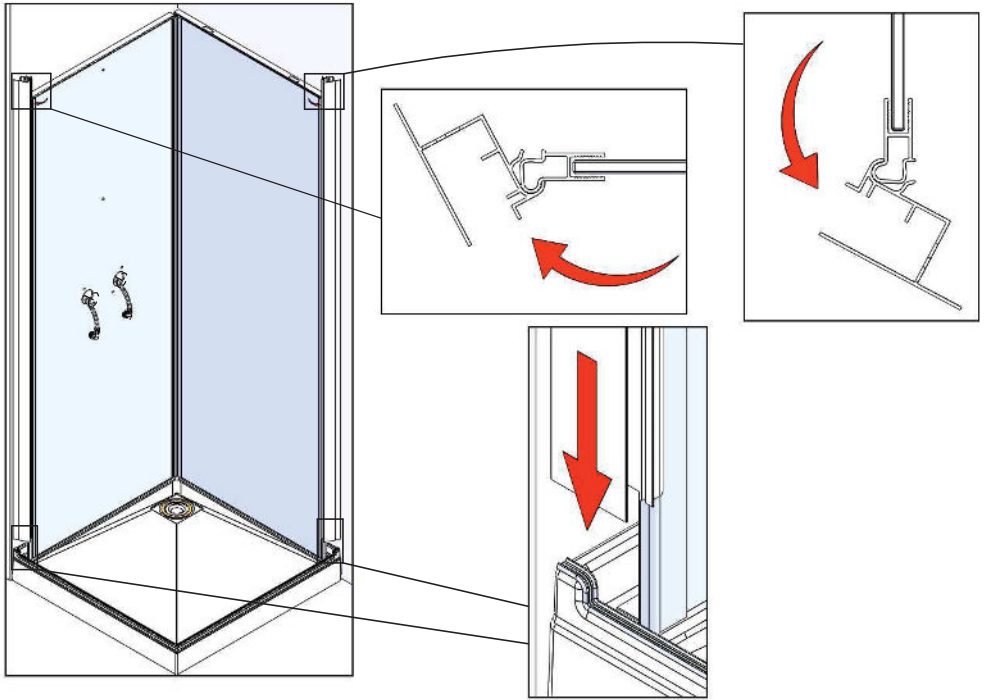

08

Raccorder vos flexibles d'alimentation avec votre mitigeur.
 Connect your supply hoses with your mixer.
 Conectar los latiguillos al grifo.
 Raccordare i flessibili di alimentazione al miscelatore.
 Sluit de watertoevoerslangen aan de kraan aan.
 Zulaufschläuche an Mischbatterie anschließen.

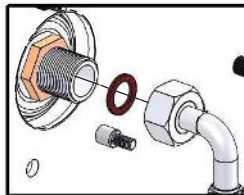
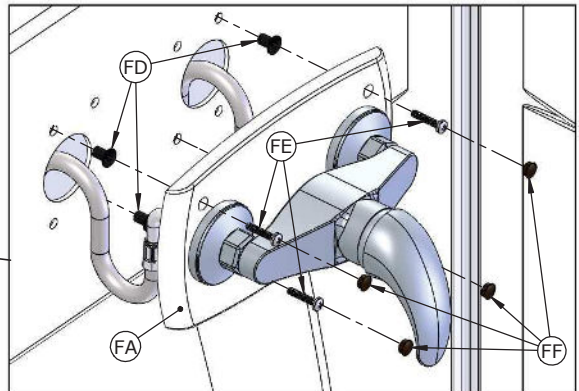
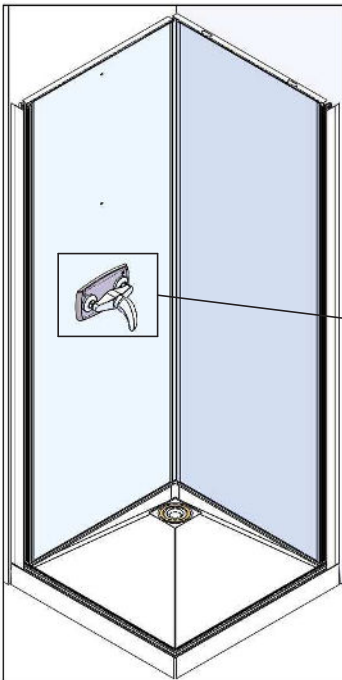

En fonction de votre version, possibilité mitigeur thermostatique ou pas de mitigeur.
 Depending on your version, possibility thermostatic mixer or no mixer.
 Según la versión, posibilidad mezclador termostático o no mezclador.
 Seconda della versione, possibilità miscelatore termostatico o non miscelatore.
 Afhankelijk van de versie, mogelijkheid thermostatische kraan of niet kraan.
 Mit oder ohne Mischbatterie, in Abhängigkeit von Ihrer Version.

09

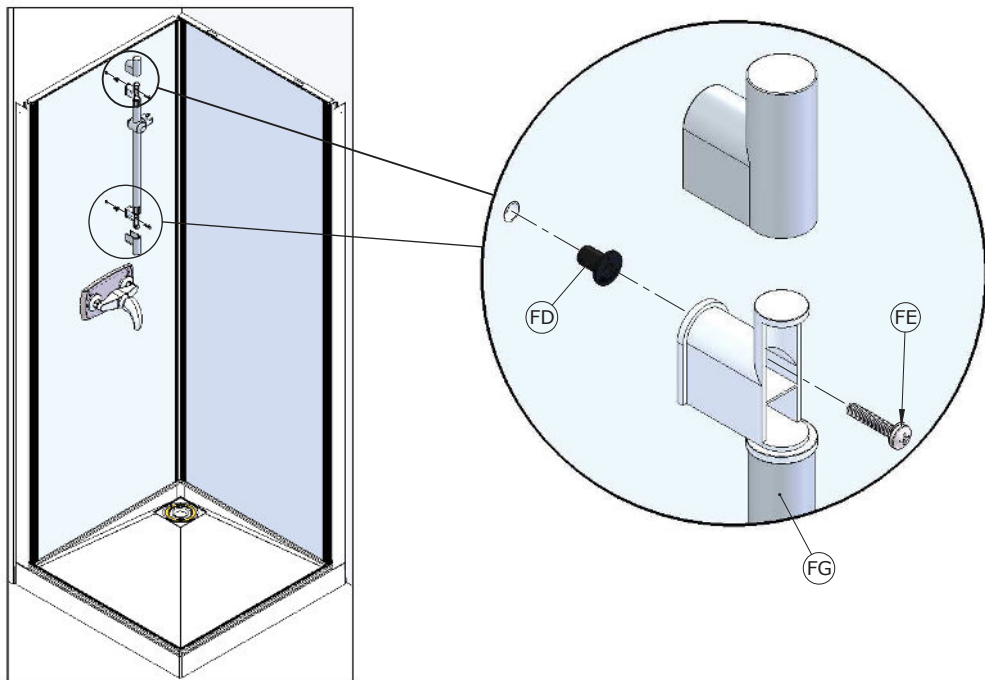

10

FR - En raison du transport et des diverses manipulations du produit, nous vous conseillons vivement de vérifier le bon serrage de chaque connexion, afin d'éviter tout problème de fuite lors de la mise en eau.

EN - Due to transportation and various product handling issues, we strongly recommend that you check that each connection is properly tightened in order to avoid any potential leakage problems when put under pressure.

ES - Debido al transporte y a las distintas manipulaciones del producto, le aconsejamos comprobar que sujeción de cada conexión sea correcta, para evitar los problemas de fuga una vez se conecte con el agua.

IT - A causa del trasporto e delle diverse manipolazioni del prodotto, vi consigliamo vivamente di controllare il buon serraggio di tutti i collegamenti allo scopo di evitare perdite d'acqua.

NL - Door het transport en de diverse logistieke handelingen met het product dient u elke slangconnectie (koppeling/aansluiting) extra te controleren op waterdichtheid alvorens u de douchecabine definitief plaatst. Hiermee vermijdt u mogelijke lekkages nadat het water op druk wordt aangesloten.

D - Nach Transport und Produkt-Handling empfehlen wir Ihnen dringend, jede Verbindung auf Dichtigkeit zu überprüfen, um beim Einlassen des Wassers jegliche Leckagen zu vermeiden.

⑪

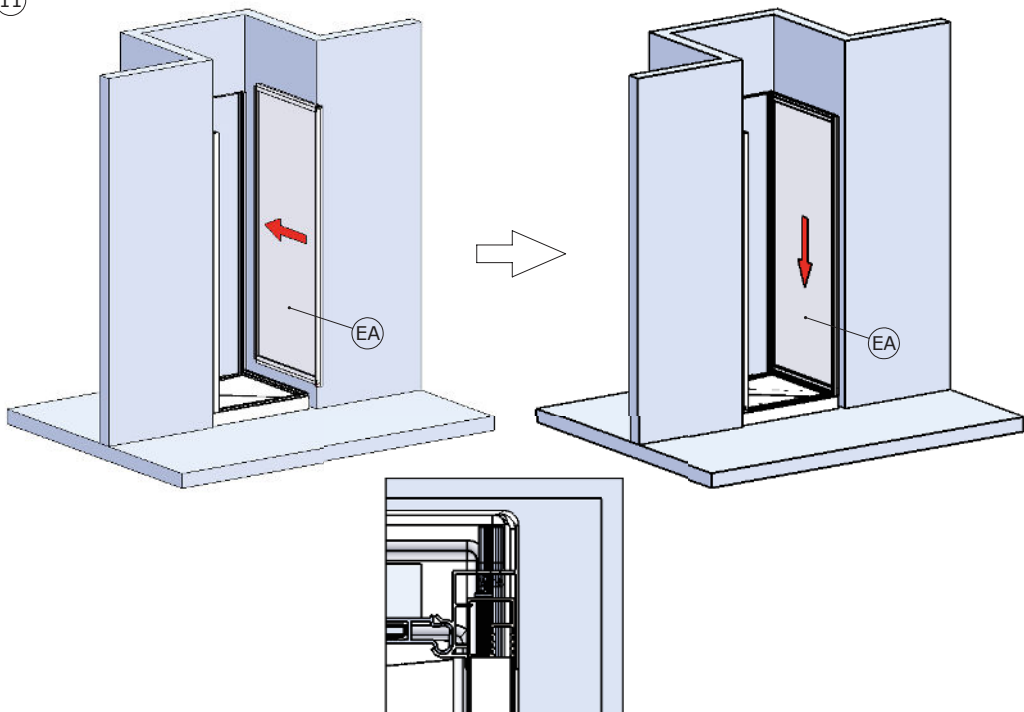

⑫

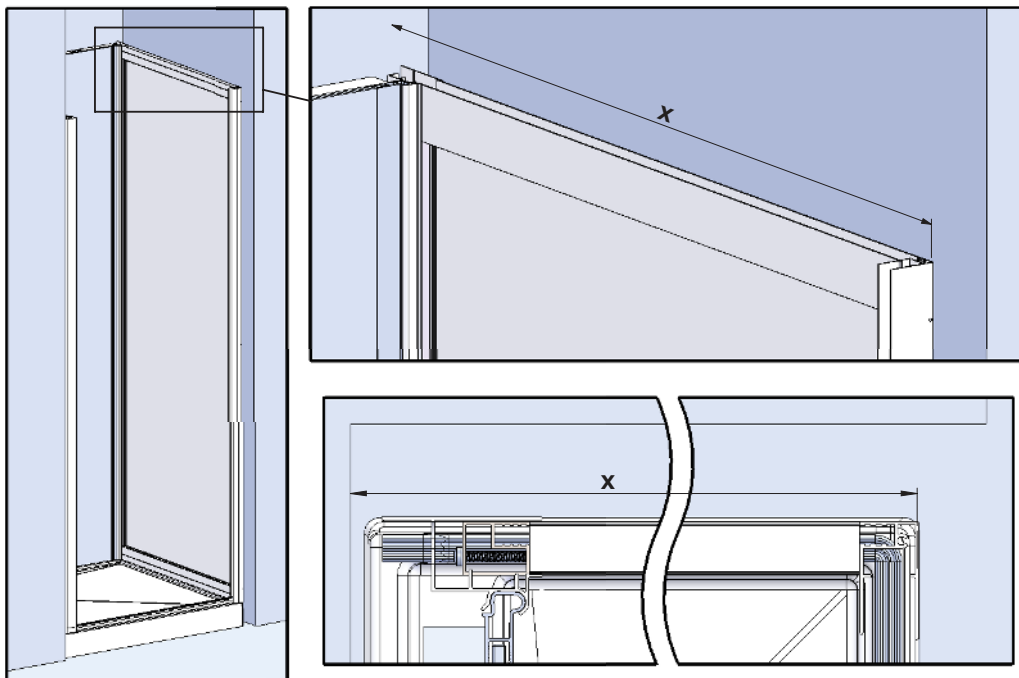

⑬

Receveur bas - Low tray - Plato bajo
 Piatto basso - Lage douchebak - Niedrige Duschtasse

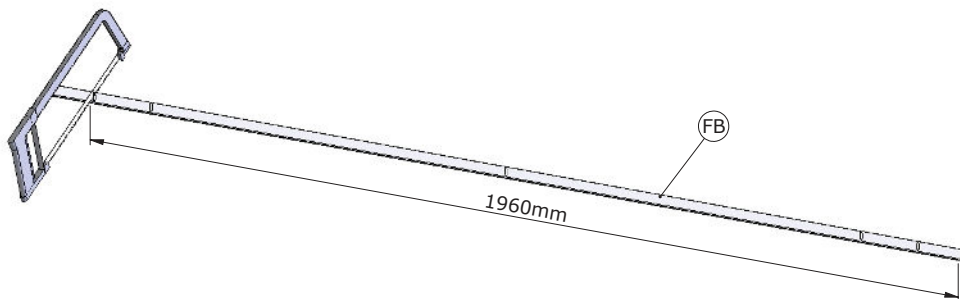

Receveur haut - High tray - Plato alto
 Piatto alto - Hoge douchebak - Hohe Duschtasse

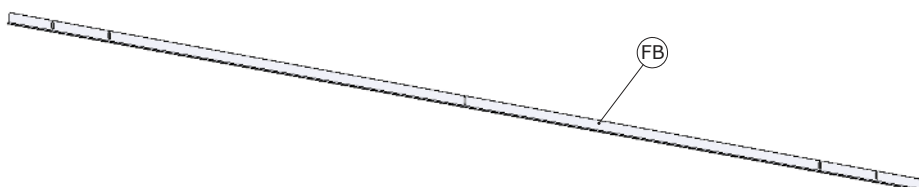

⑭

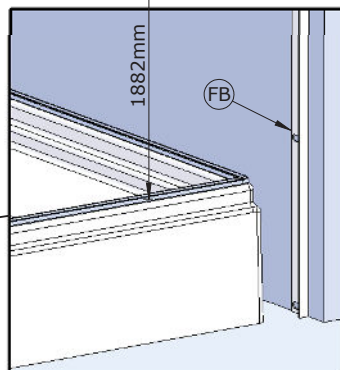
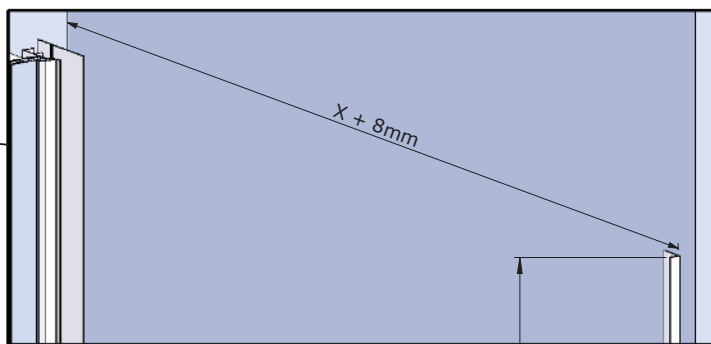
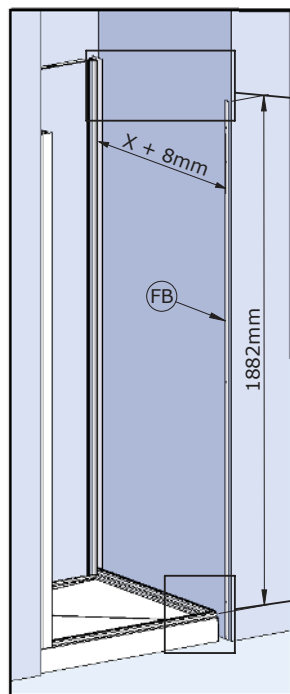

15

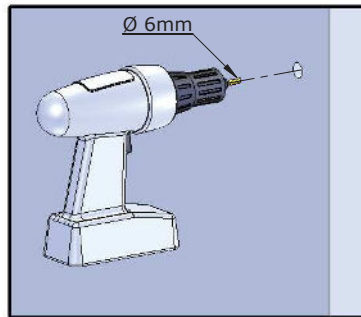
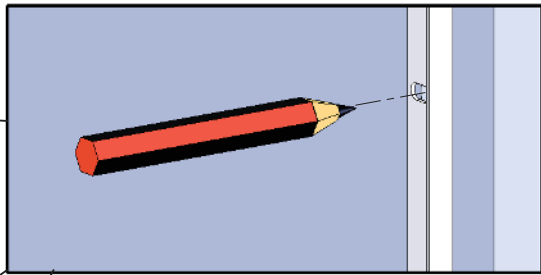
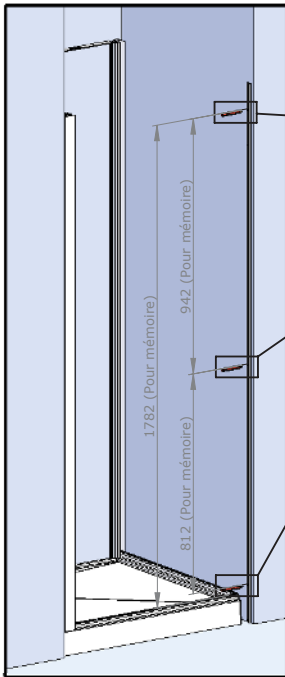

16

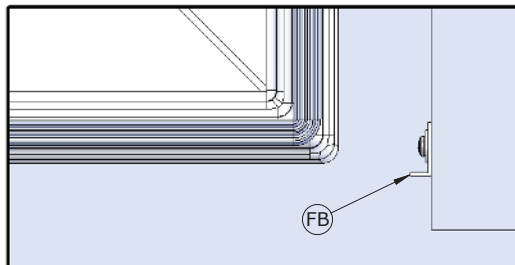
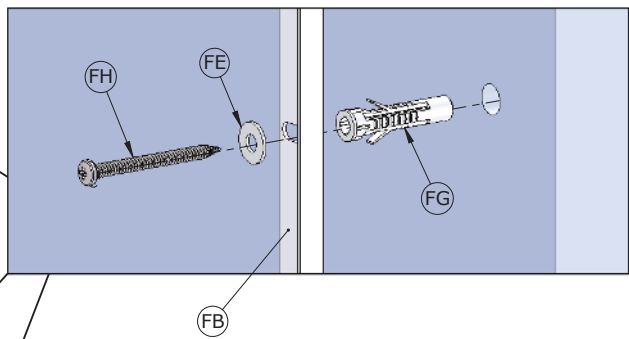
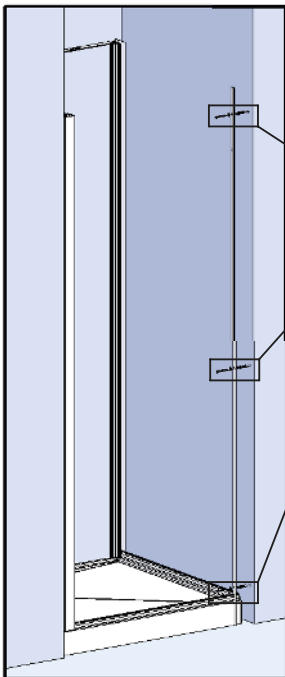

⑰

1P

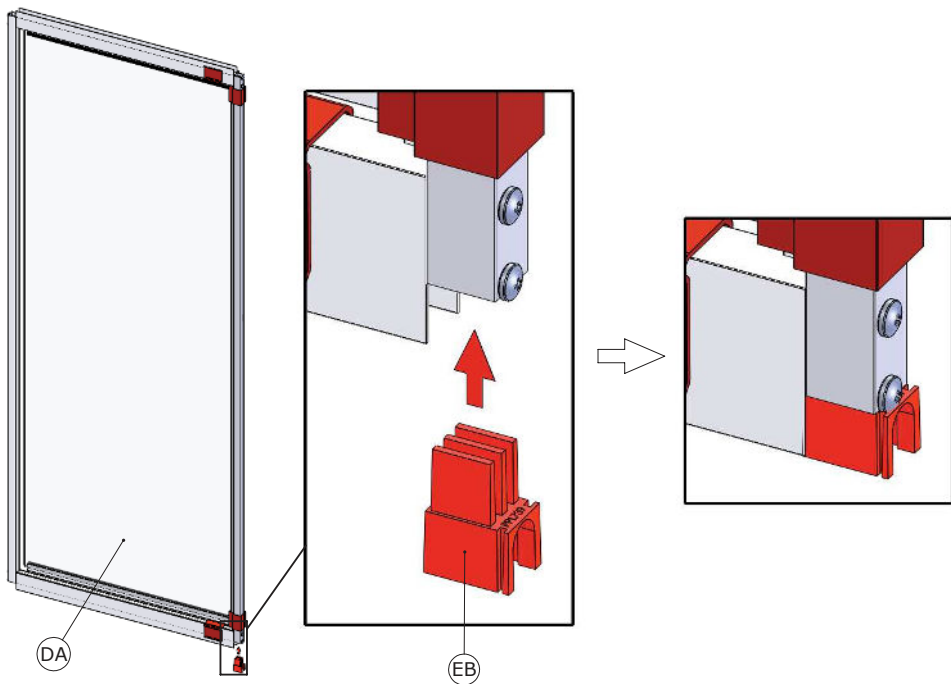

2P

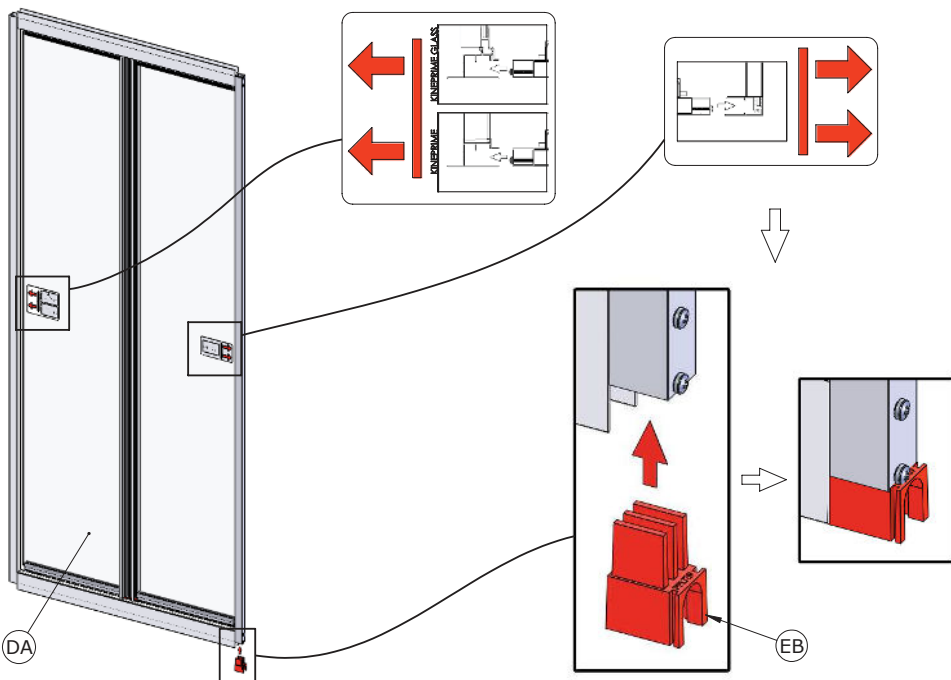

18

1P

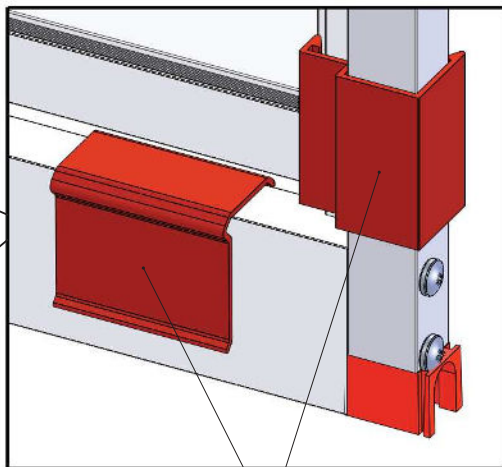
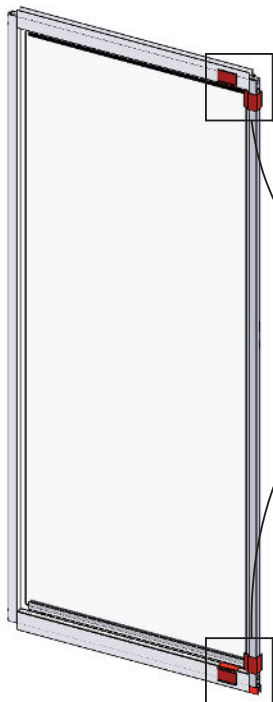

Retirer
Remove
Quitar
Rimuovere
Verwijderen
Entfernen

2P

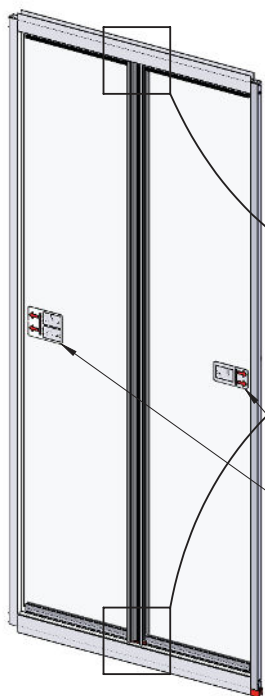

Intérieur douche - Inside shower - Interior ducha
Doccia interni - Binnen douche - Innenansicht der Kabine

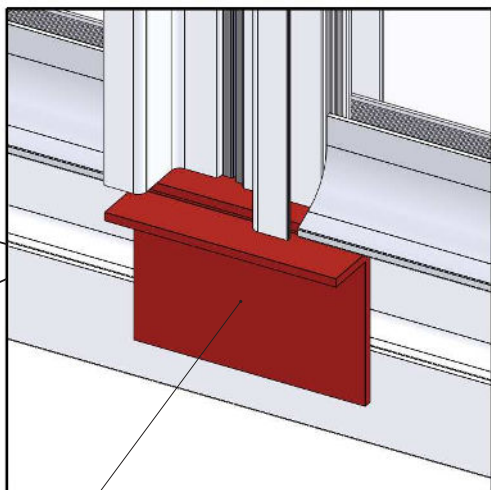

Retirer
Remove
Quitar
Rimuovere
Verwijderen
Entfernen

①9

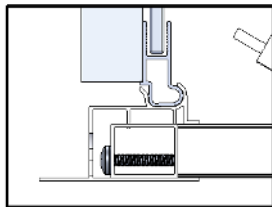
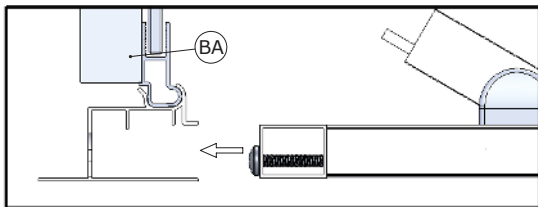
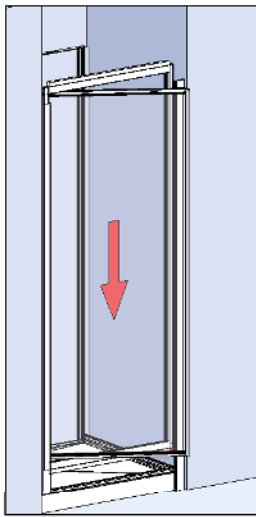
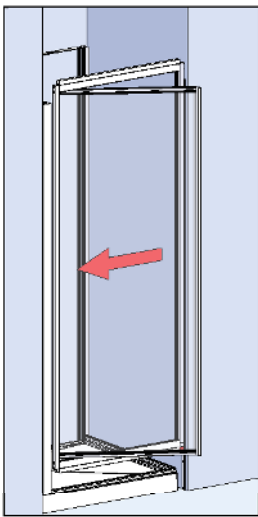

②0

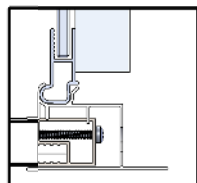
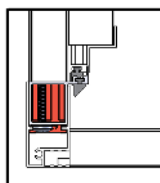
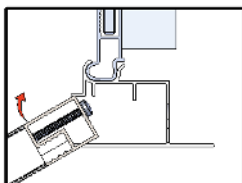
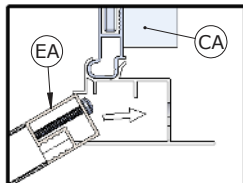
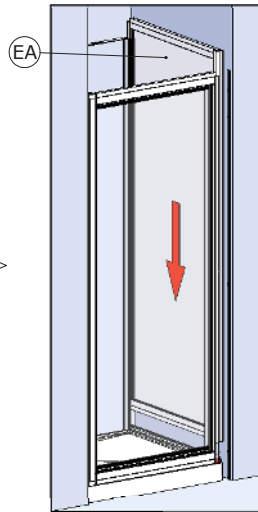
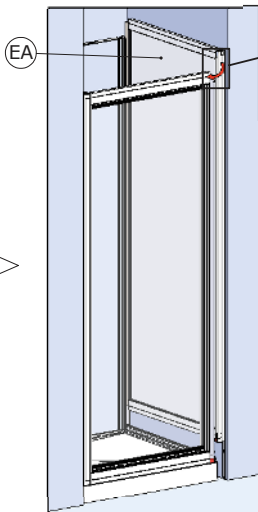
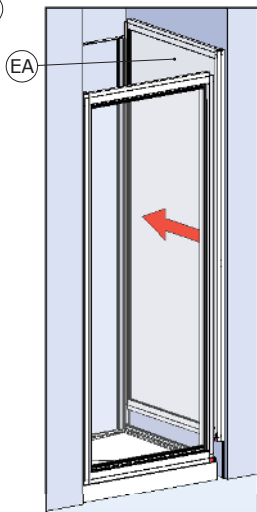

(21)

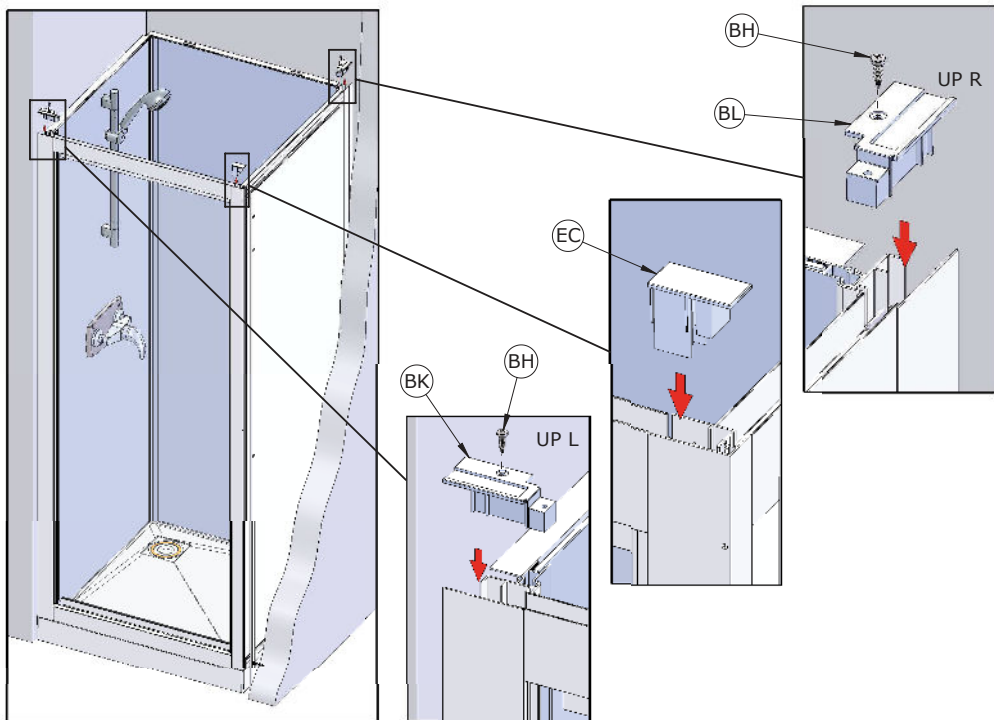

(22)

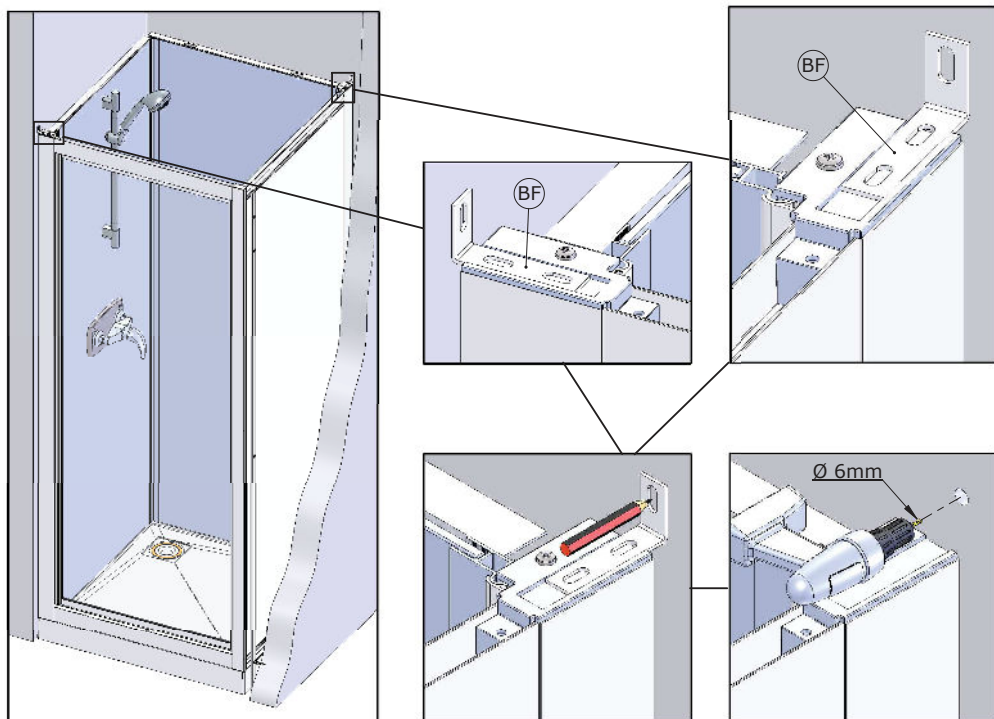

23

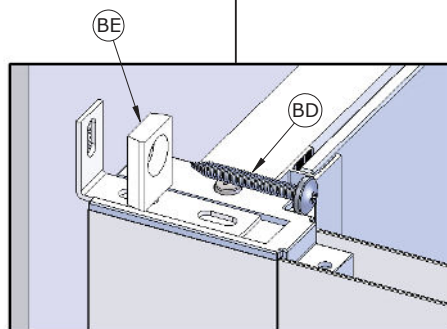
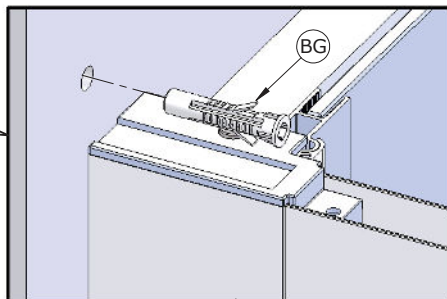
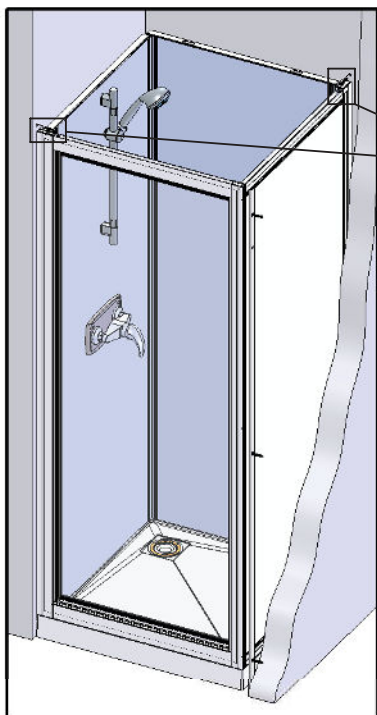

24

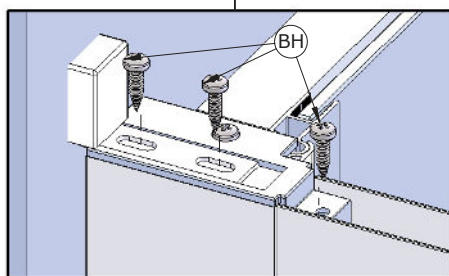
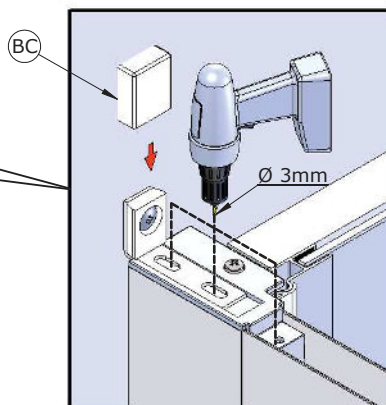
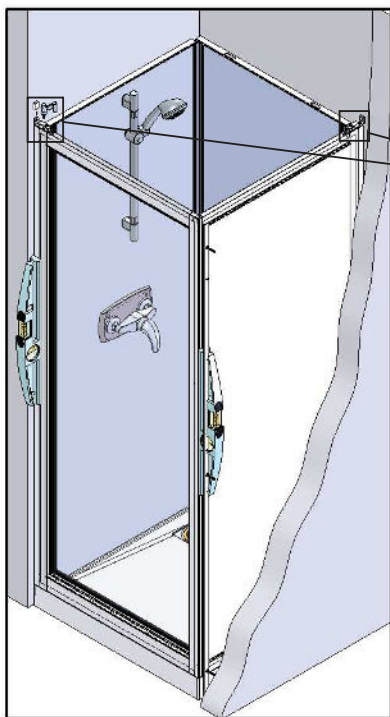

(25)

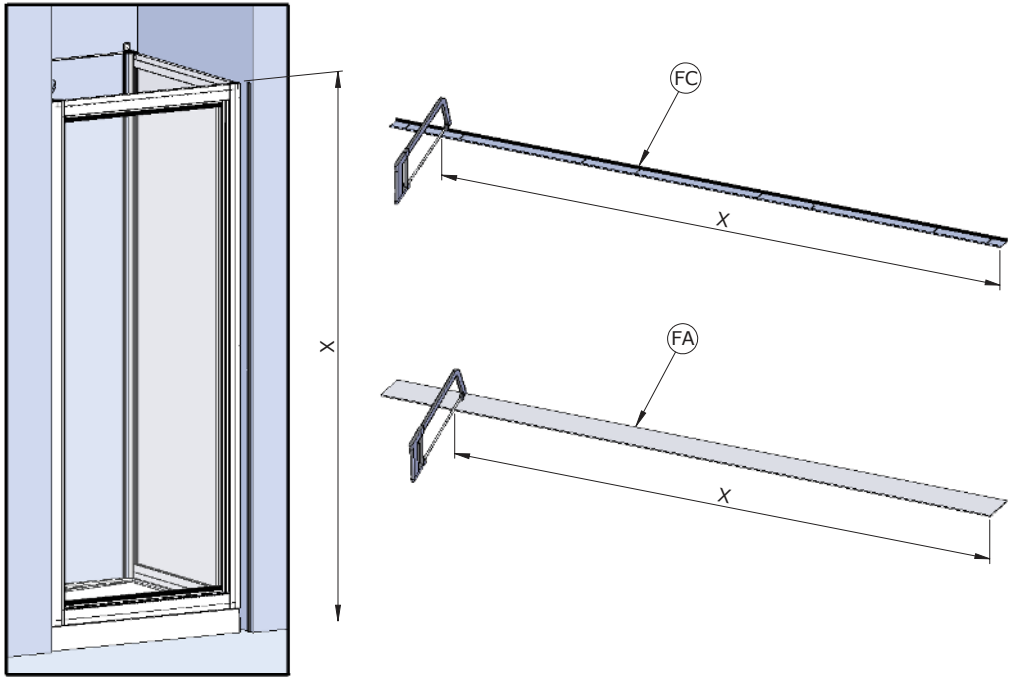

(26)

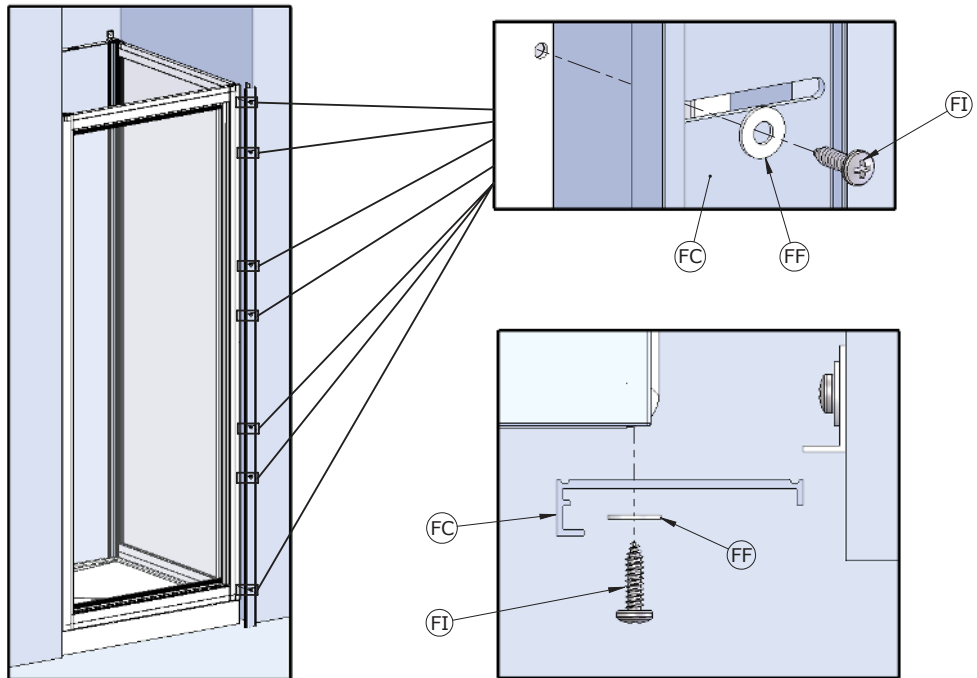

(27)

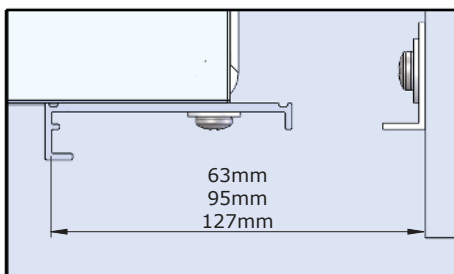
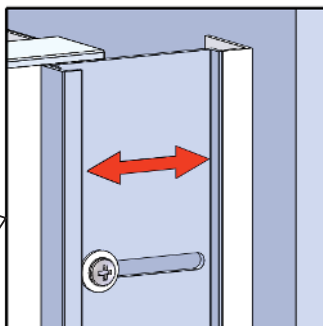
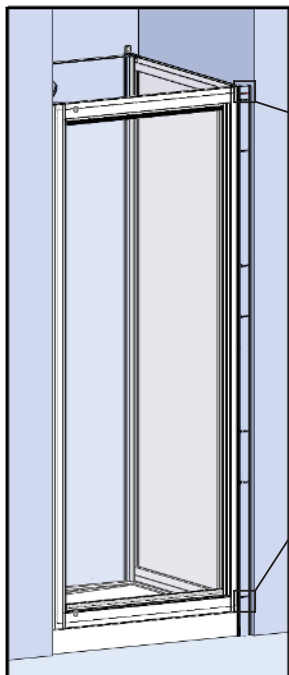

(28)

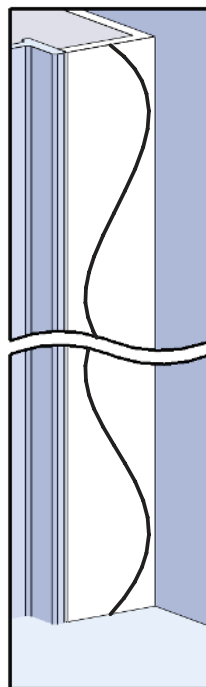
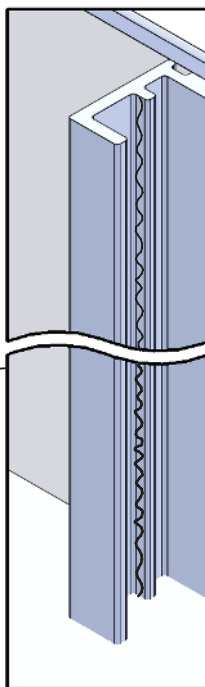
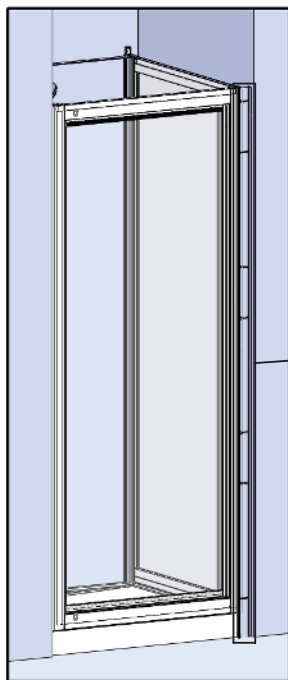

29

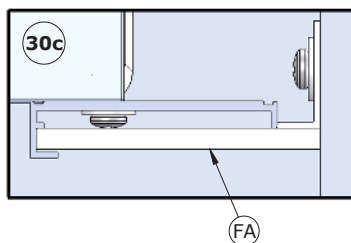
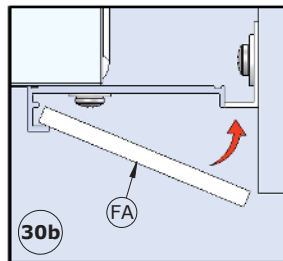
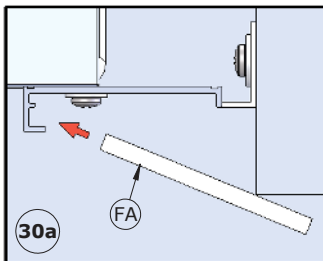
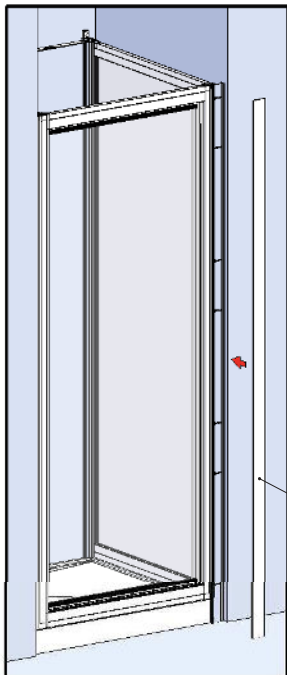

30

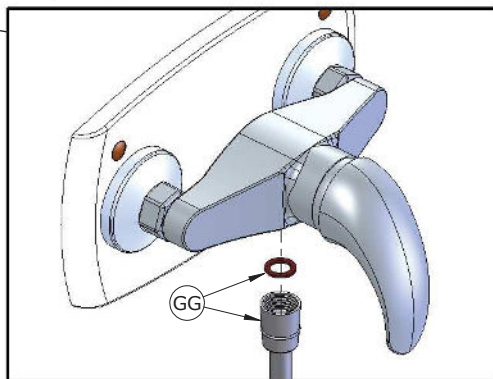
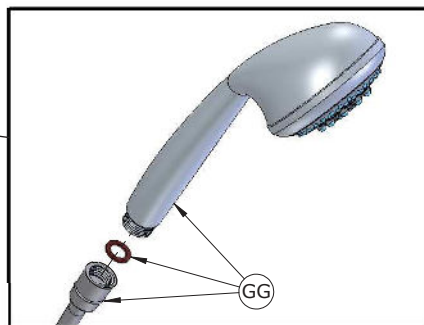
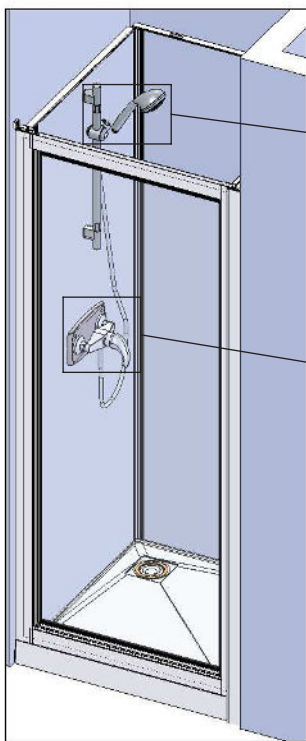

(31)

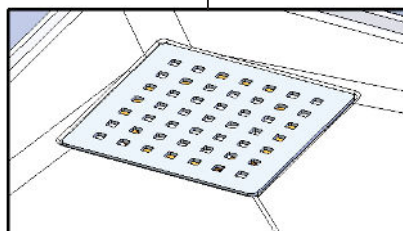
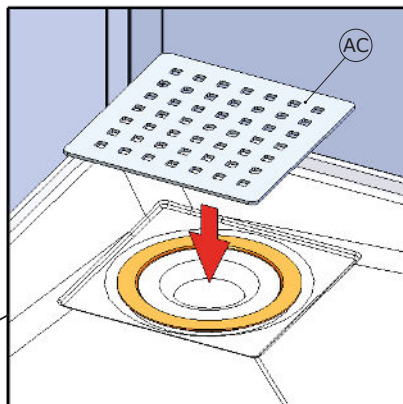
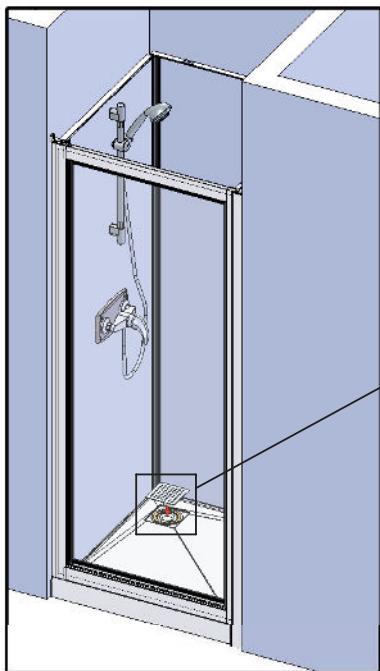

(32)

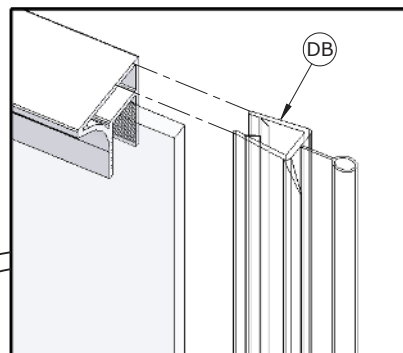
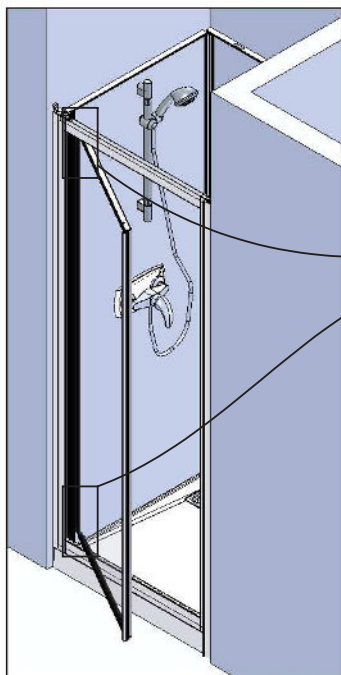

Intérieur douche - Inside shower - Interior ducha
 Doccia interni - Binnen douche - Innenansicht der Kabine

Extérieur - Outside - Exterior
 Esterno - Buitenkant - Außen

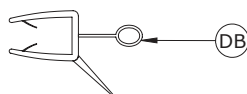

Intérieur - Inside - Interior
 Interno - Binnenkant - Innen

Ajuster si nécessaire - Cut if necessary
 Recortar si necesario - Tagliare si necesario
 Snijden indien nodig - Bei Bedarf zuschneiden

1P

33

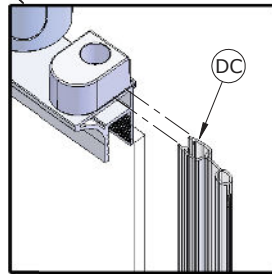
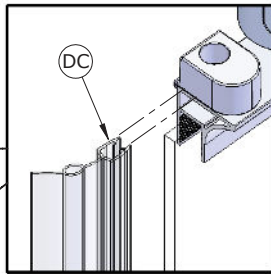
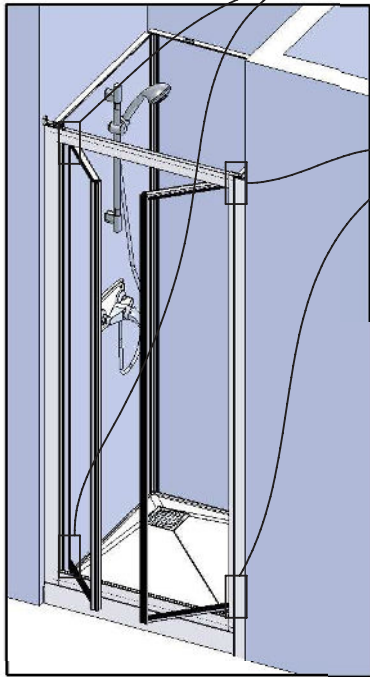

Intérieur douche - Inside shower - Interior ducha
Doccia interni - Binnen douche - Innenansicht der Kabine

Extérieur - Outside - Exterior
Esterno - Buitenkant - Außen

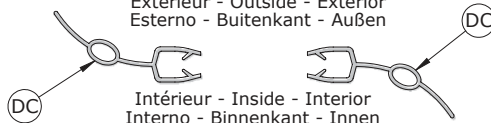

Intérieur - Inside - Interior
Interno - Binnenkant - Innen

Ajuster si nécessaire - Cut if necessary
Recortar si necesario - Tagliare si necessario
Snijden indien nodig - Bei Bedarf zuschneiden

34

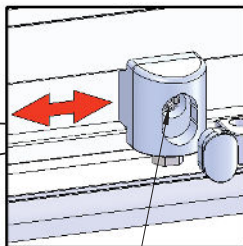
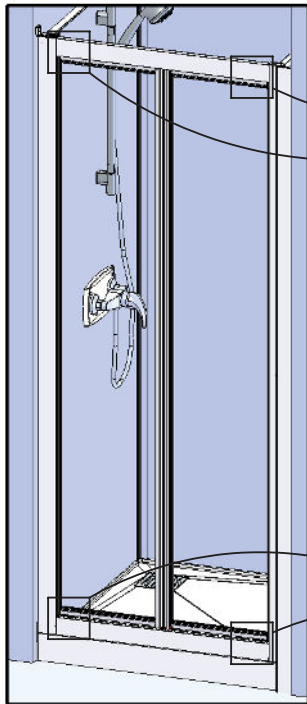

Ajuster si nécessaire, puis resserrer
Adjust if necessary, and tighten
Ajustar si es necesario, y apriete
Regolare se necessario, e stringere
Stel indien nodig, en draai
Bei Bedarf ausrichten, und festziehen

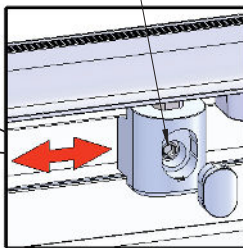
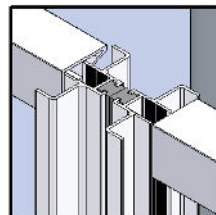



F

POUR LA PROTECTION ELECTRIQUE DE VOTRE DOUCHE, IL EST NECESSAIRE DE RELIER LES ORGANES METALLIQUES DE VOTRE PRODUIT AU CIRCUIT EQUIPOTENTIEL DE VOTRE INSTALLATION.

VOUS POUVEZ CONTACTER VOTRE INSTALLATEUR HABITUEL, IL SAURA VOUS CONSEILLER.

GB

FOR THE ELECTRONIC PROTECTION OF YOUR SHOWER, THE METAL PARTS OF YOUR PRODUCT SHOULD BE CONNECTED TO THE EQUIPOTENTIAL CIRCUIT OF YOUR INSTALLATION.

CONTACT YOUR USUAL SHOWER FITTER FOR ADVICE.

E

PARA LA PROTECCIÓN ELÉCTRICA DE SU DUCHA, SERÁ NECESARIO CONECTAR LOS ELEMENTOS METÁLICOS DE SU PRODUCTO AL CIRCUITO EQUIPOTENCIAL DE SU INSTALACIÓN.

PÓNGASE EN CONTACTO CON SU INSTALADOR HABITUAL, ÉSTE SABRÁ ACONSEJARLE.

I

PER GARANTIRE LA PROTEZIONE ELETTRICA DELLA DOCCIA OCCORRE COLLEGARE LE PARTI METALLICHE AL CIRCUITO EQUIPOTENZIALE DELL'APPARECCHIO.

CHIEDERE CONSIGLIO ALL'ELETTICISTA DI FIDUCIA.

NL

VOOR DE ELEKTRISCHE BESCHERMING VAN UW DOUCHE MOETEN DE METALEN DELEN VAN UW PRODUCT WORDEN AANGESLOTEN OP HET EQUIPOTENTIALE CIRCUIT VAN UW INSTALLATIE.

NEEM HIERVOOR CONTACT OP MET UW NORMALE INSTALLATEUR, HIJ KAN U ADVISEREN.

D

FÜR DEN ELEKTRISCHEN SCHUTZ IHRER DUSCHE IST ES ERFORDERLICH, DIE METALLELEMENTE IHRES PRODUKTS MIT DEM ÄQUIPOZENTIALSCHALTkreis IHRES INSTALLATEURS ZU VERBINDEN.

NEHMEN SIE DIESBEZÜGLICH GGF. KOMTAKT MIT IHREM HAUSINTALLATEUR AUF UND LASSEN SIE SICH BERATEN.



SAV
SERVICE HELPLINES
ASSISTENZA POST-VENDITA
SERVICIO POSTVENTA

FRANCE

02 40 21 29 45

SCHWEIZ

(01) 748 17 44

UK

020 8842 0033

ESPANA

93 544 60 76

IRELAND

04697 33102

NEDERLAND

0475 487 100

DEUTSCHLAND

0800 82 27 82 0

BELGIË

+31 475 487 100

ITALIA

(0382) 6181

BELGIQUE

+31 475 487 100

OSTEREICH

+43 1 710 60 70

РОССИЯ

963 19 40, 773 67 22