

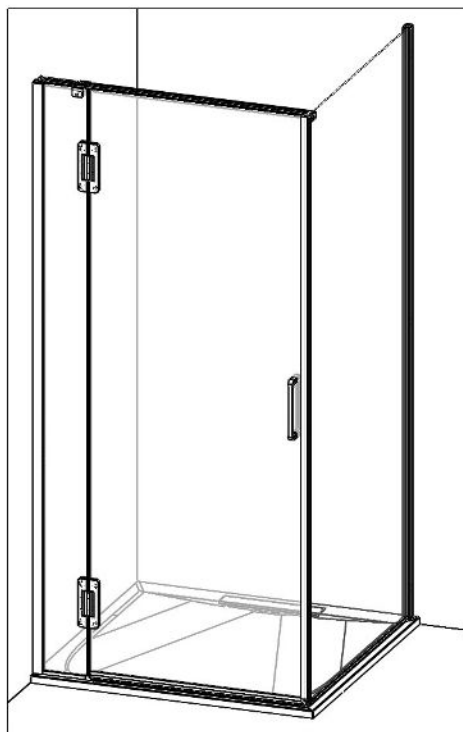

- F Notice de montage ● GB Installation instructions
- E Manual de instalación ● I Istruzioni di montaggio
- NL Montage-instructies ● D Montageanleitung

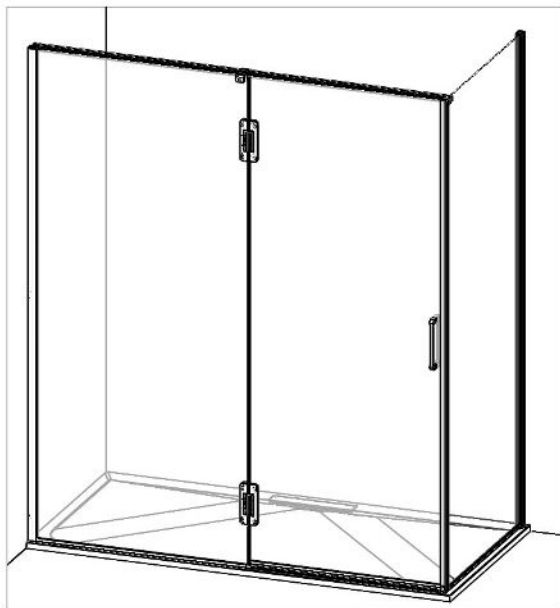
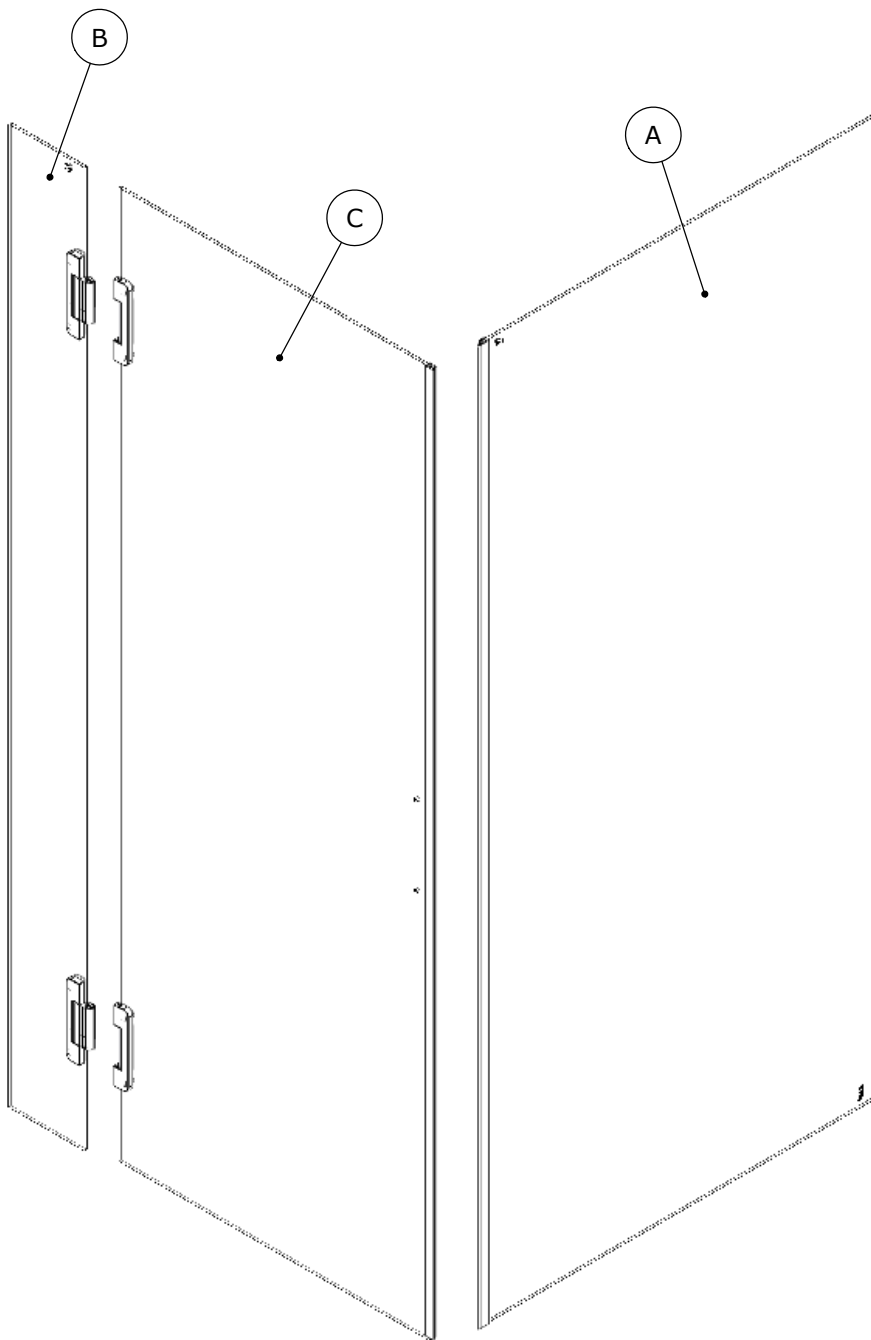

- Attention aux étapes :
- Check installation steps :
- Atención a los pasos :
- Attenzione ai passi :
- Aandacht voor de stappen :
- Achtung vor den Schritten :

P. 6 - 10 - 31

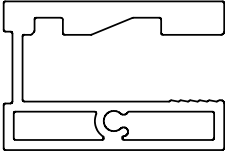
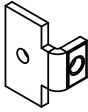
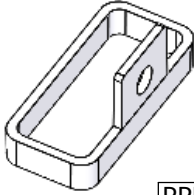
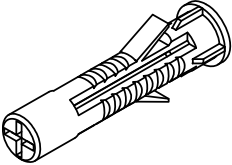
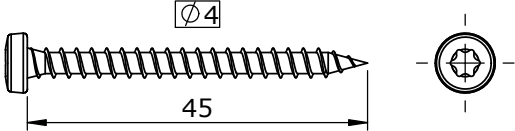
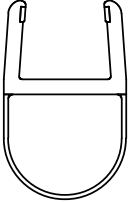
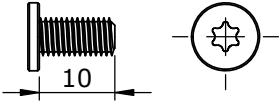
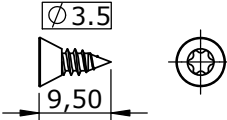
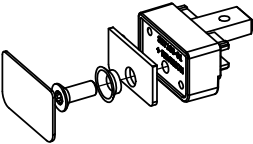
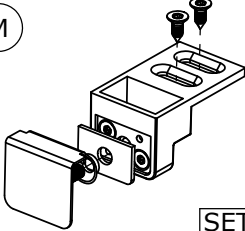

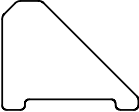
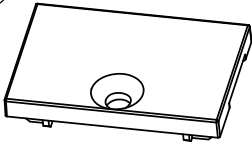
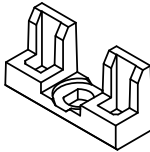
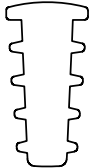
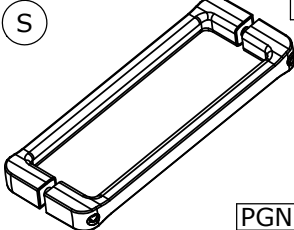
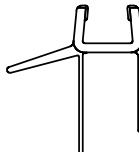
<p>D x2</p>  <p style="text-align: right;">6373</p>	<p>E x1</p>  <p style="text-align: right;">EQU83</p>	<p>F x1</p>  <p style="text-align: right;">PPL1452</p>
<p>G x7</p>  <p style="text-align: right;">CHE02</p>	<p>H x7</p>  <p style="text-align: right;">VIS231</p>	
<p>I x1</p>  <p style="text-align: right;">JOI323</p>	<p>J x2</p>  <p style="text-align: right;">VIS275</p>	<p>K x2</p>  <p style="text-align: right;">VIS261</p>
<p>L x1</p>  <p style="text-align: right;">SET188</p>	<p>M x1</p>  <p style="text-align: right;">SET187</p>	<p>N x1</p>  <p style="text-align: right;">Lg = 1850mm 6372</p>
<p>O x1</p>  <p style="text-align: right;">Lg = 1050mm 6285</p>	<p>P x2</p>  <p style="text-align: right;">PPL1453</p>	<p>Q x6</p>  <p style="text-align: right;">PPL1196</p>
<p>R x2</p>  <p style="text-align: right;">JOI299</p>	<p>S x1</p>  <p style="text-align: right;">PGN54</p>	<p>T x1</p>  <p style="text-align: right;">JOI322</p>

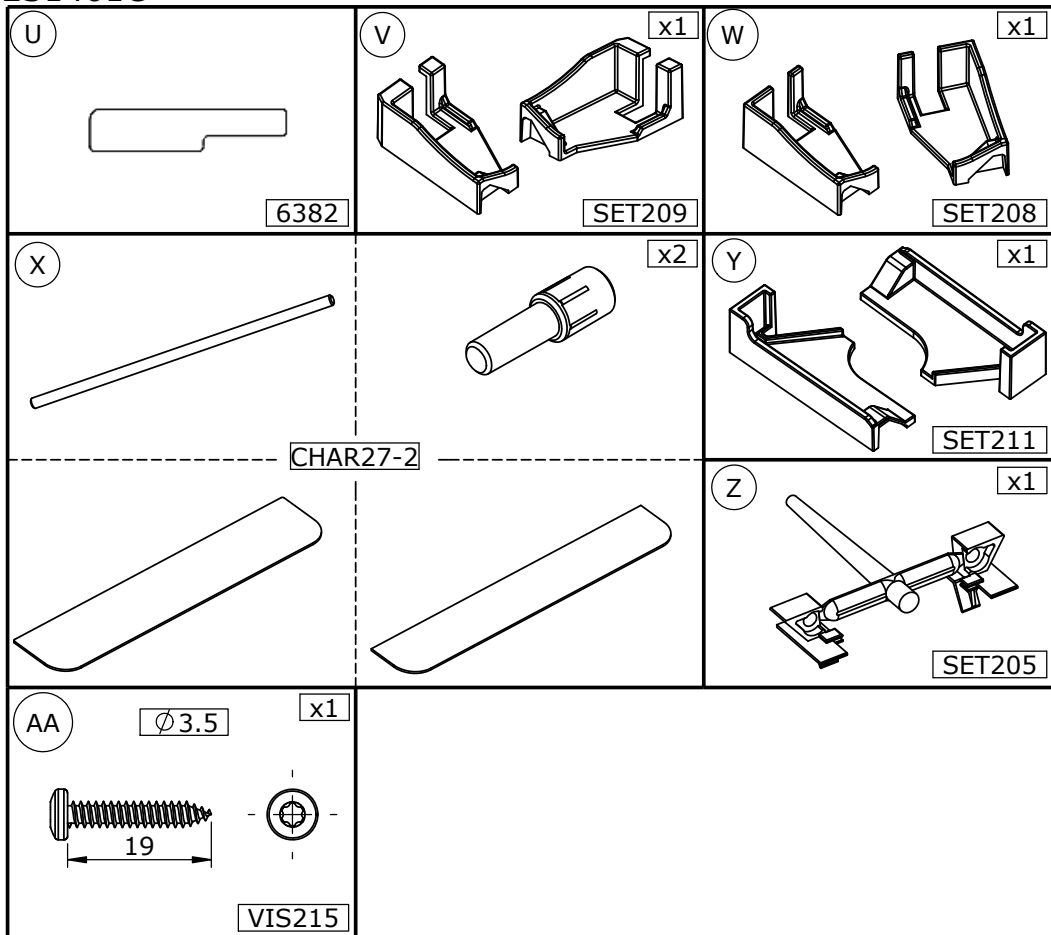

- Les quantités données sont les quantités utiles au montage. les sachets fournis contiennent des pièces supplémentaires.
- The quantities given are what are required for the installation. There may be some surplus in the package provide.
- Las cantidades indicadas son las cantidades necesarias para el montaje. Las bolsitas incluidas contienen piezas suplementarias.
- Le quantità fornite sono le quantità necessarie al montaggio. I sacchetti forniti contengono pezzi supplementari.
- De aangegeven aantallen zijn bestemd voor de montage. De bijgeleverde zakjes bevatten extra onderdelen
- Die Mengenangaben beziehen sich auf die für die Montage nötigen Teile. Eventuell weitere beige packte Teile ignorieren.

F Matériel nécessaire **GB** Tools required **E** Material necesario
I Materiale necessario **NL** Benodigdheden **D** Erforderliche Werkzeuge

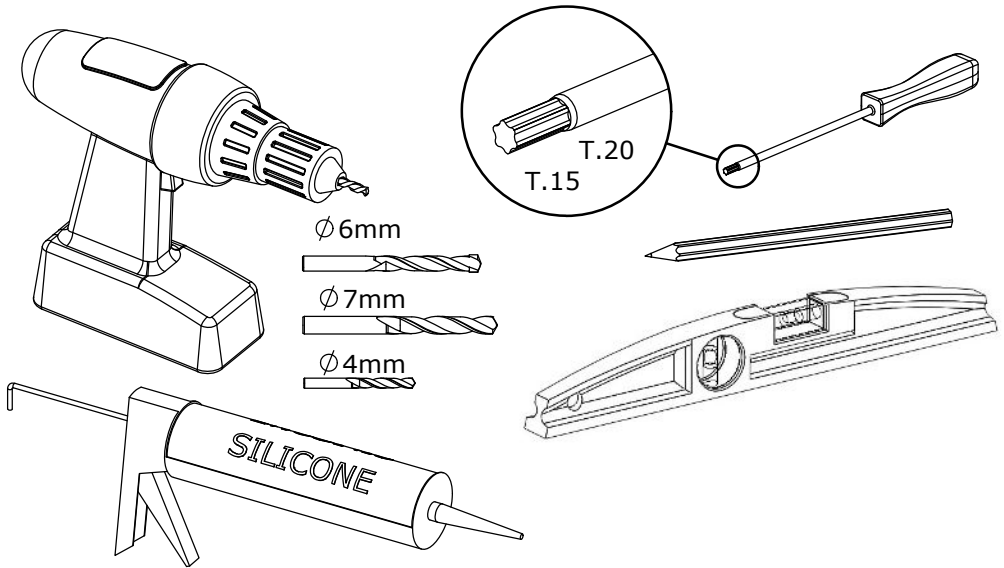

- Utiliser un silicone adapté au matériau de chaque support (faïence, acrylique, etc.)
- Use a silicone sealant that is intended for the surrounding materials (ceramic, acrylic, etc)
- Usar una silicona adecuada para cada tipo de material (loza, acrílico, etc.)
- Utilizzare un silicone adatto a qualsiasi materiale (ceramica, acrilico ecc.)
- Gebruik een silicone die geschikt is voor het materiaal (wandtegels, acryl,...)
- Verwenden Sie ein Silikon, das auf das Material des jeweiligen Trägers abgestimmt ist (Steingut, Acryl etc.)

F Fourni dans la boîte d'accessoires **GB** Supplied in the accessory box
E Se suministra en la caja de accesorios **I** Fornito nella scatola degli accessori
NL Meegeleverd in de verpakking **D** Im Zubehörset enthalten

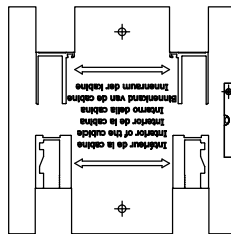

CAR342



● REVERSIBILITE ● REVERSIBILITY

● REVERSIBILITA ● OMKEERBAARHEID ● WAHLWEISE MONTAGE

● MONTAGE A GAUCHE

● LEFT HAND

● MONTAGGIO A SINISTRA

● MONTAGE LINKS

● MONTAGE LINKS

● MONTAGE A DROITE

● RIGHT HAND

● MONTAGGIO A DESTRA

● MONTAGE RECHTS

● MONTAGE RECHTS

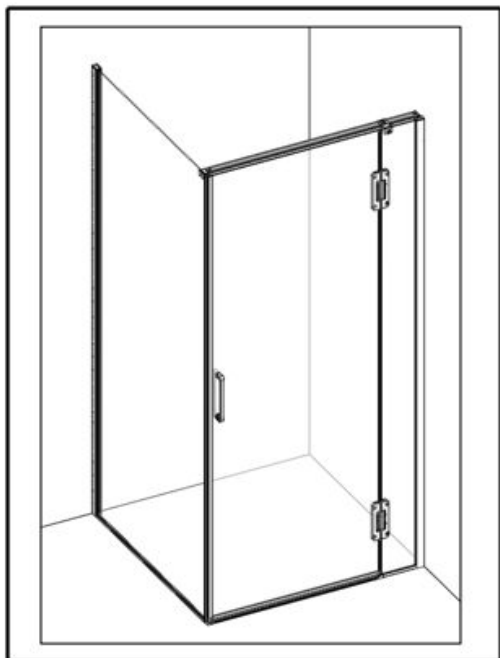
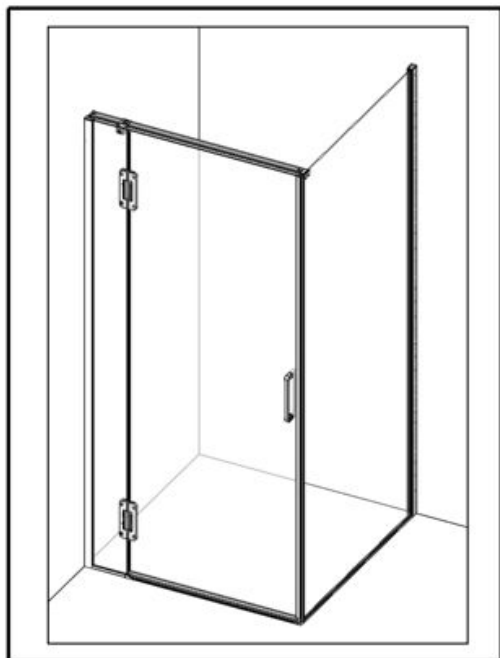

● Vous avez la possibilité de réaliser un montage à droite ou un montage à gauche. Notre notice d'installation décrit un montage à gauche. Si vous voulez réaliser un montage à droite, il vous suffit d'inverser le montage.

● This cubicle can be installed either left or right hand. These installation instructions show a left hand installation.

● Avete la possibilità di effettuare il montaggio a destra o a sinistra. Il nostro manuale descrive il montaggio a sinistra. Se volete realizzare il montaggio a destra è sufficiente invertire varie fasi di montaggio.

● U kunt de douchecabine rechts of links monteren. Onze handleiding beschrijft de links montage van de cabine. Keer de montage om als u de cabine rechts wilt monteren.

● Sie haben die Möglichkeit, eine Montage auf der linken Seite oder eine Montage auf der rechten Seite durchzuführen. Unsere Montageanleitung beschreibt eine Montage auf der linken Seite. Wenn Sie die Montage lieber auf der rechten Seite durchführen wollen, müssen Sie nur den Montageprozess umkehren.

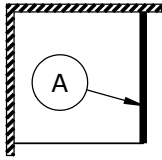
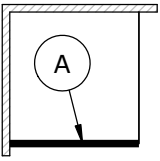

- Si receveur ^{GB} If shower tray
 ● Se piatto
 ● Als douchebak ● Wenn Duschanne

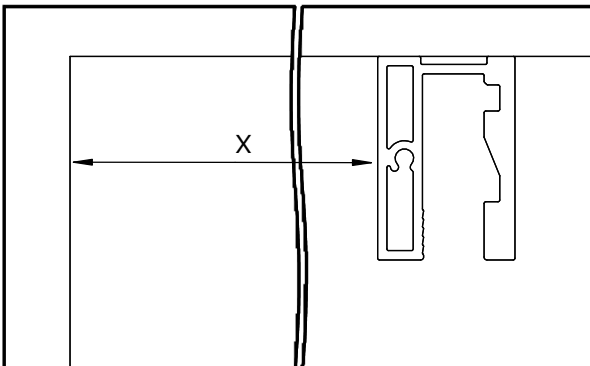
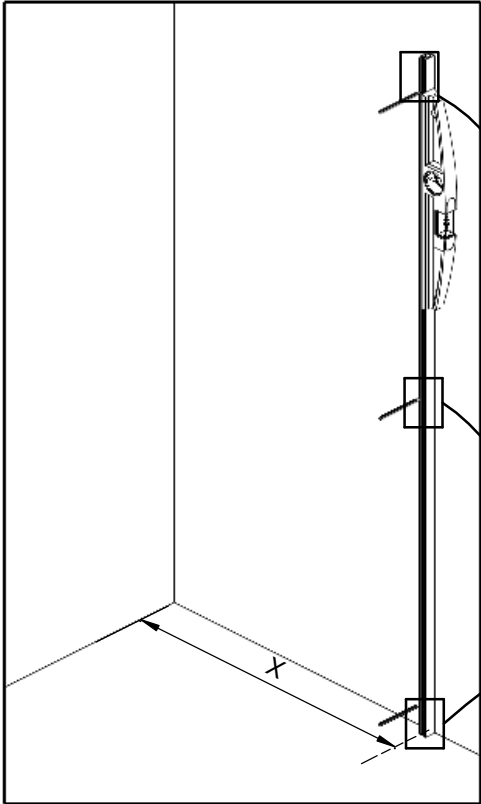
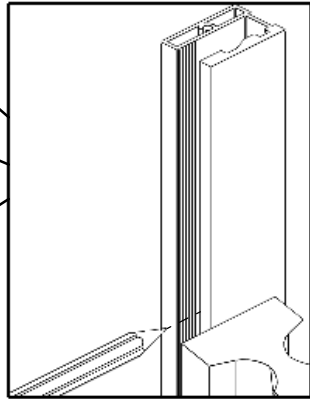
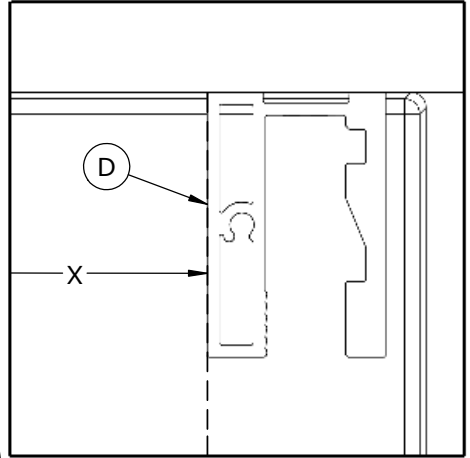

DIMENSION (cm)	X (mm)
70	652-667
80	752-767
90	852-867
100	952-967
120	1152-1167
140	1352-1367
160	1552-1567
170	1652-1667
180	1752-1767

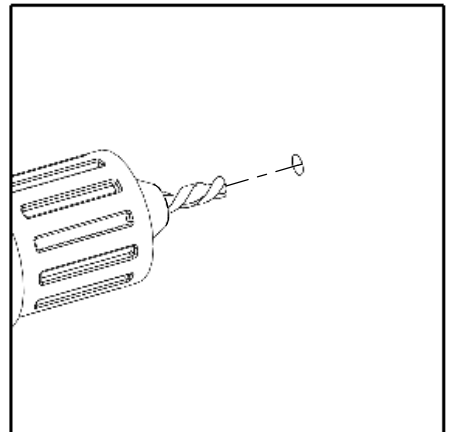
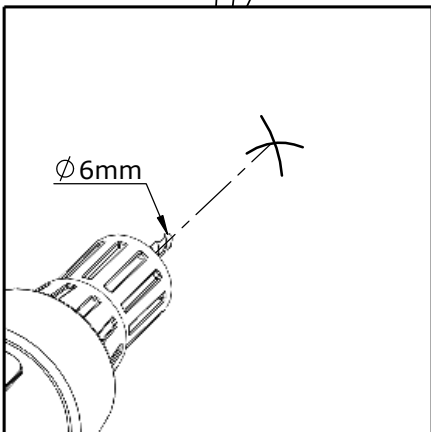
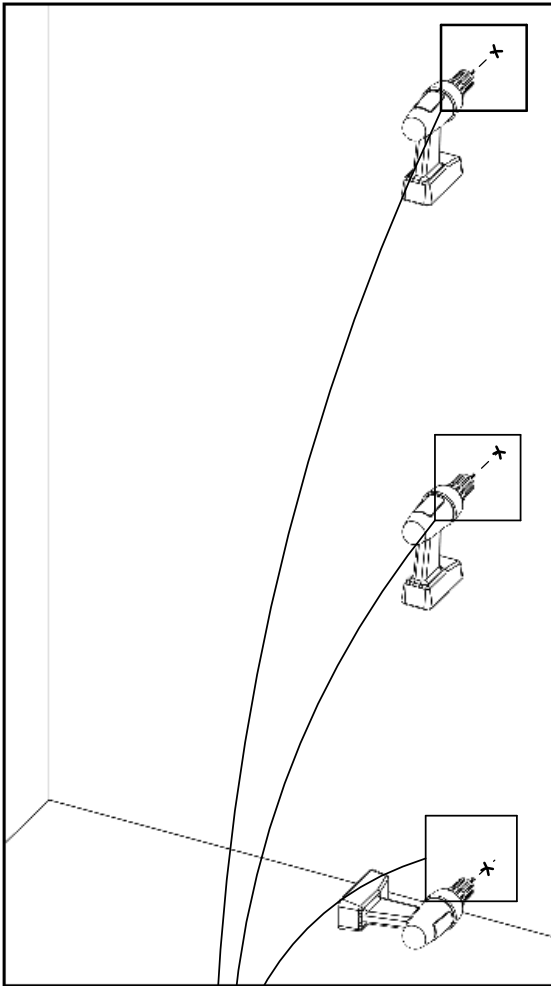

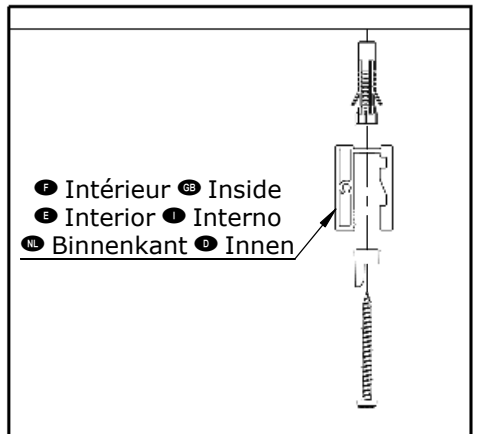
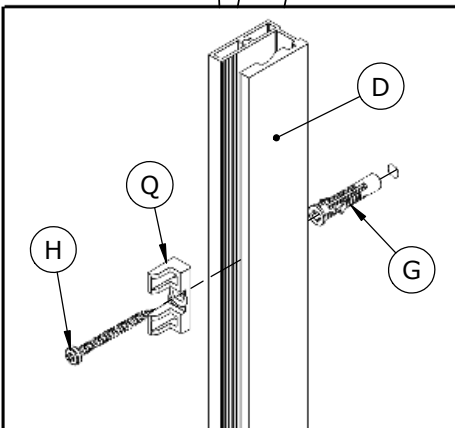
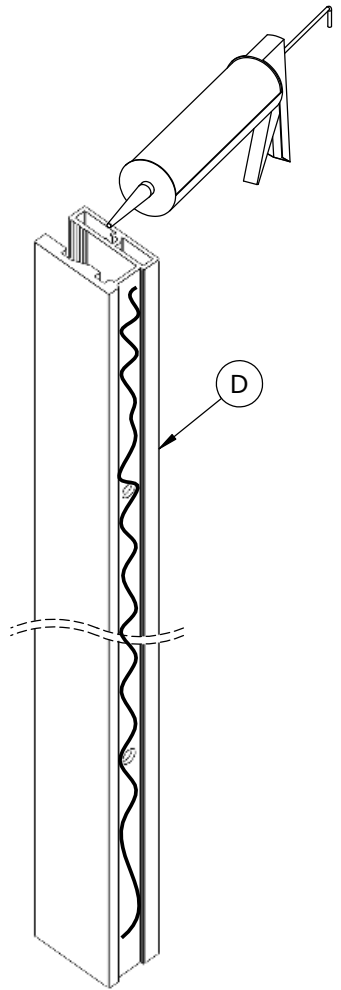
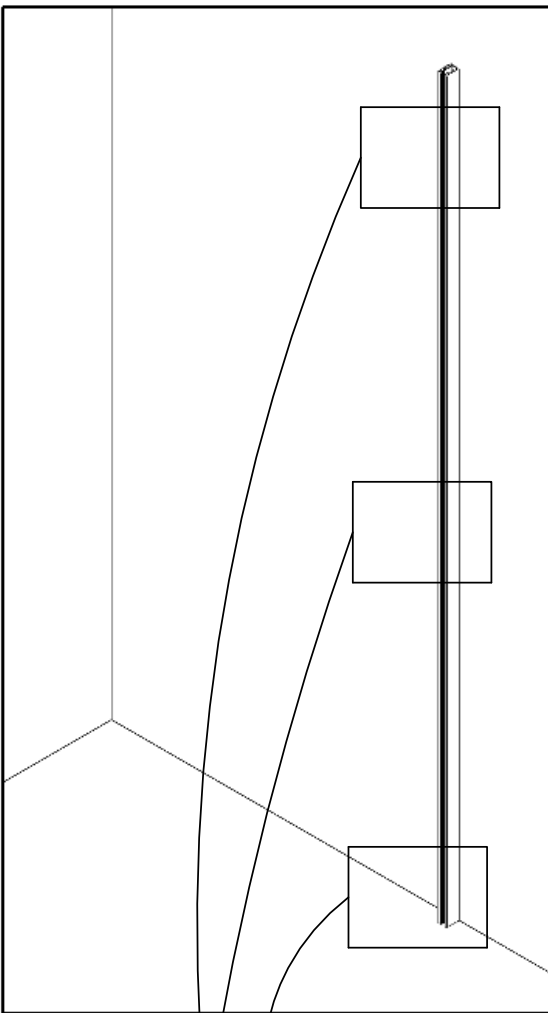

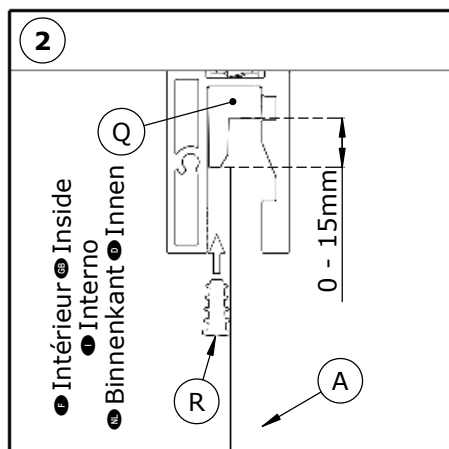
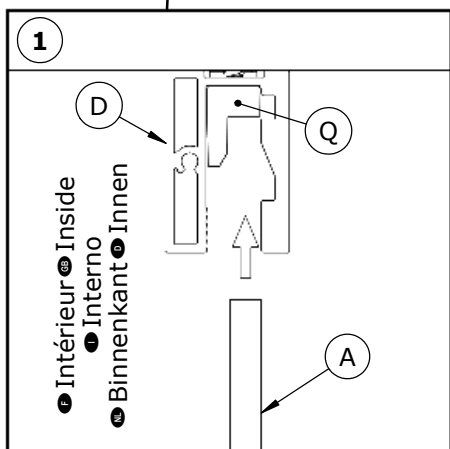
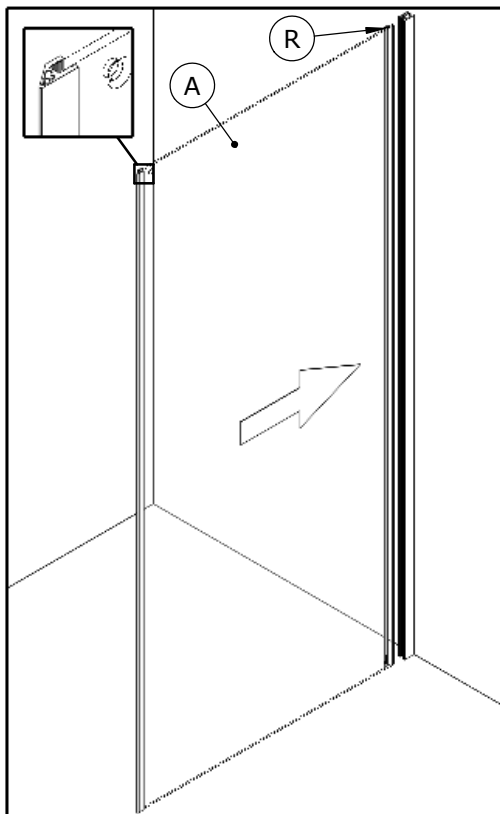
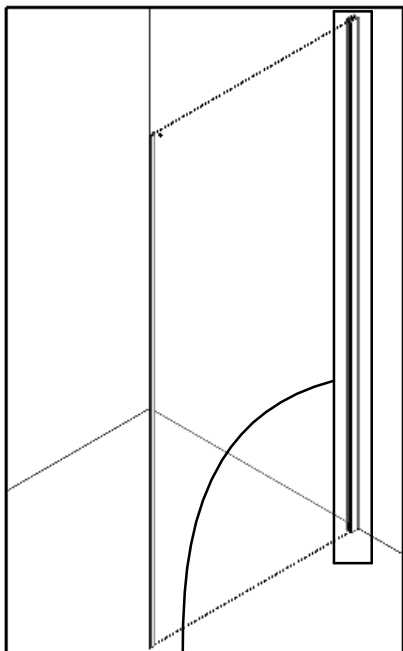

- Ajuster puis verrouiller
● Fit then block
- Regolare e poi bloccare
● Afstellen en slot
● Ausrichten und sperren

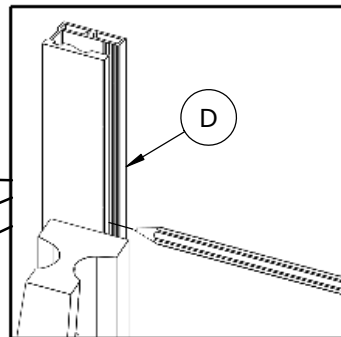
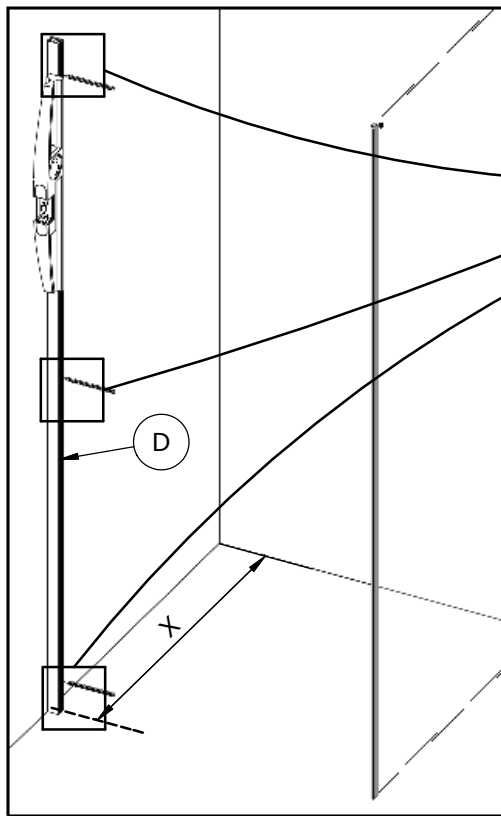

- ① Si receveur ② If shower tray
 ③ Se piatto ④ Als douchebak
 ⑤ Wenn Duschwanne

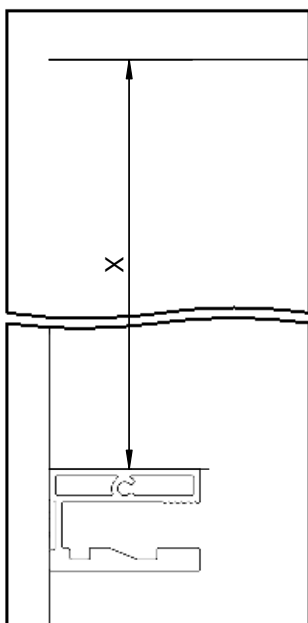
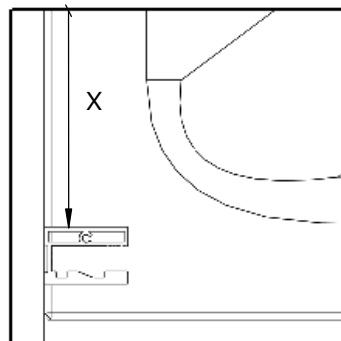

DIMENSIONS (cm)	X (mm)
70	652 - 667
80	752 - 767
90	852 - 867
100	952 - 967
120	1152 - 1167

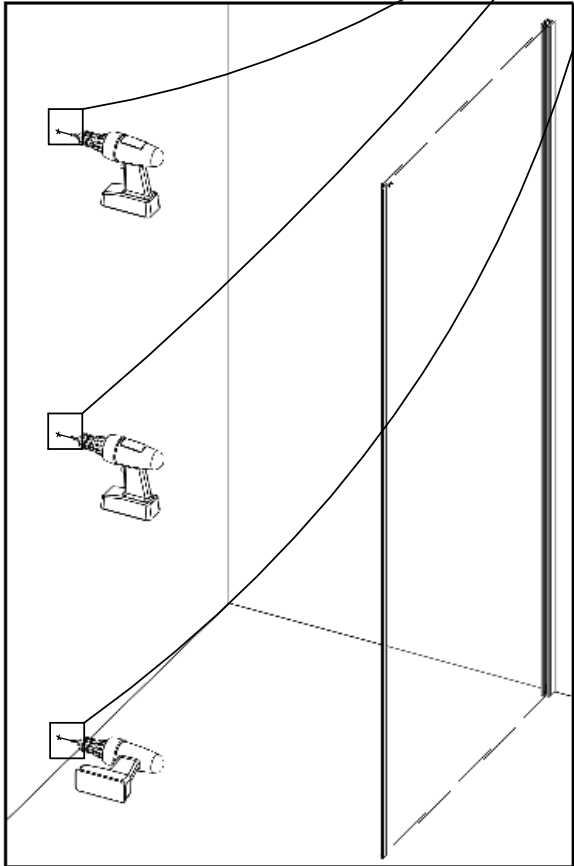
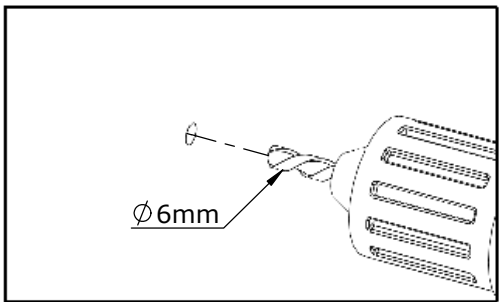

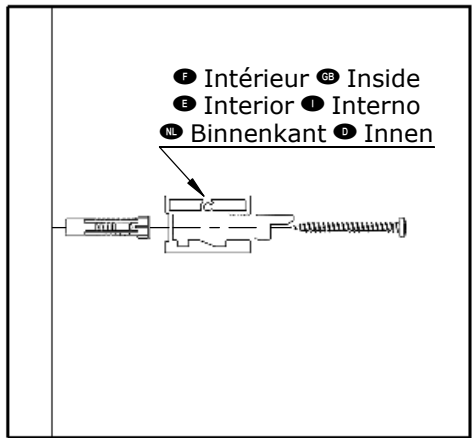
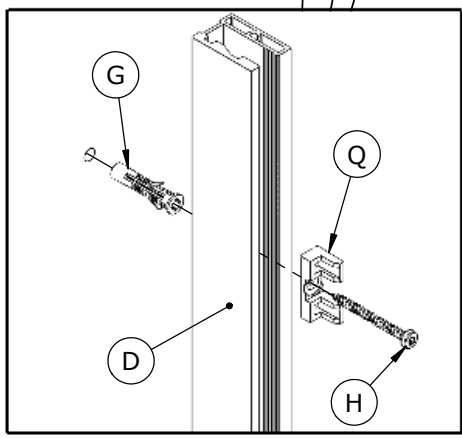
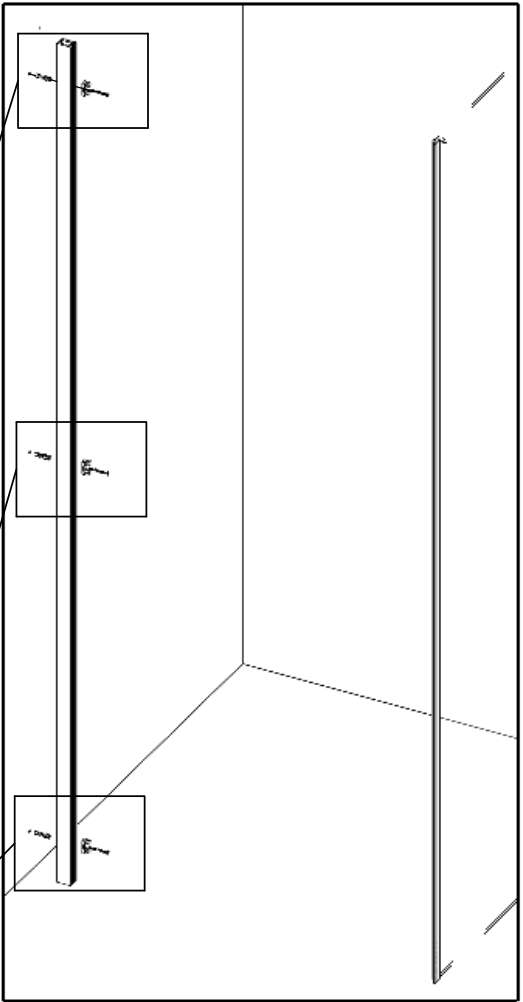
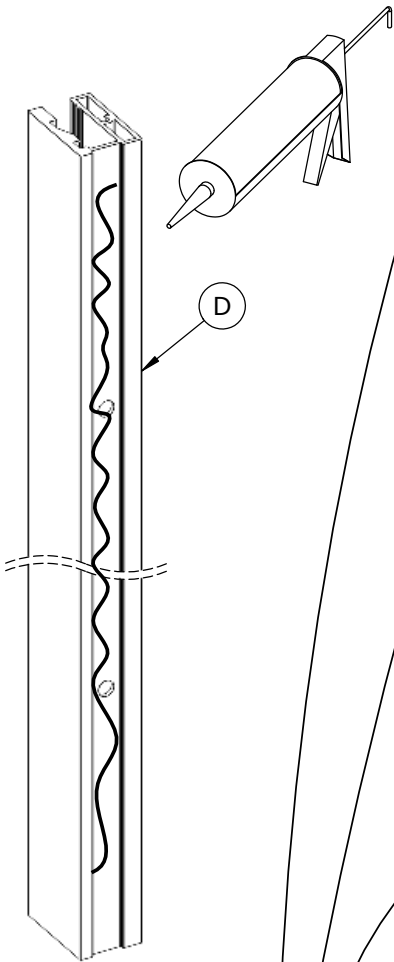

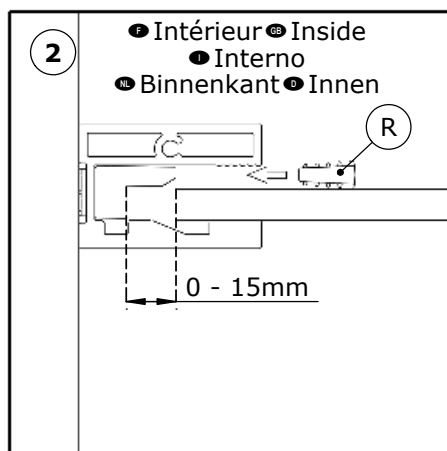
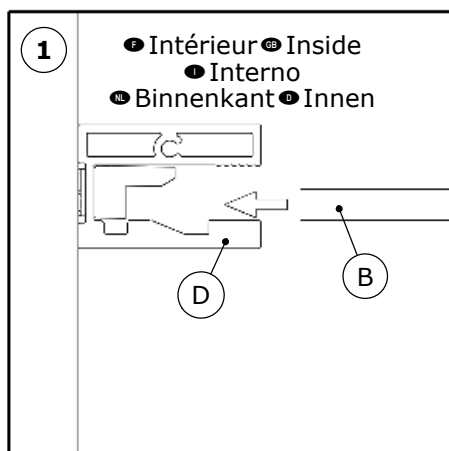
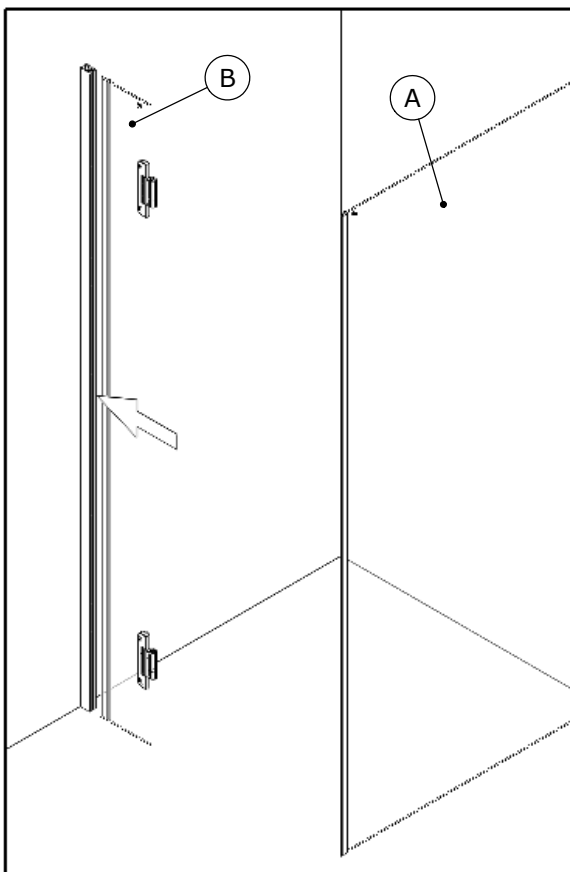
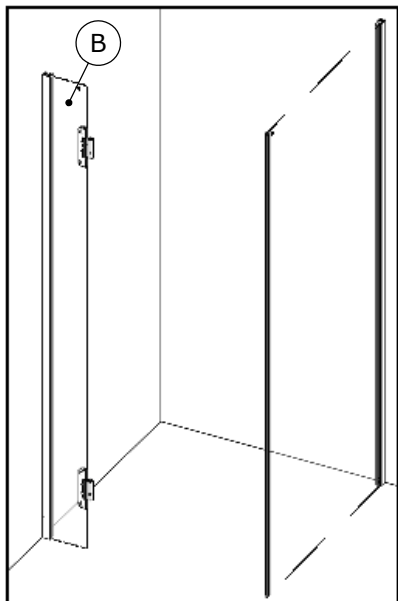

- Ajuster puis verrouiller
- Fit then block
- Regolare e poi bloccare
- Afstellen en slot
- Ausrichten und sperren

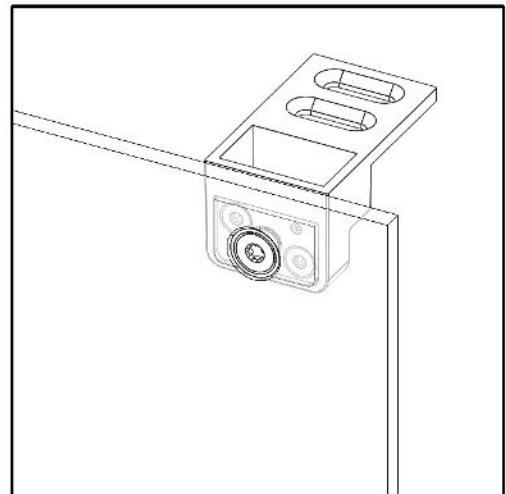
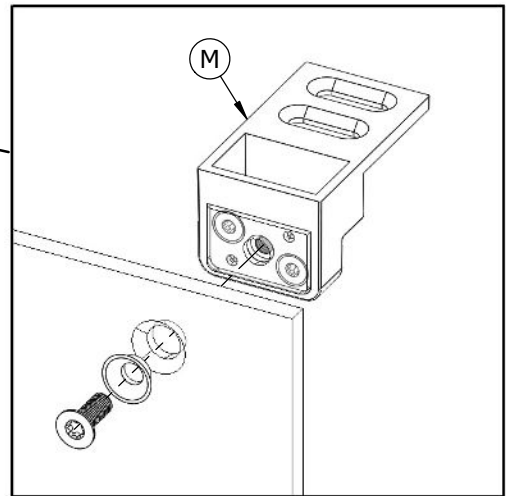
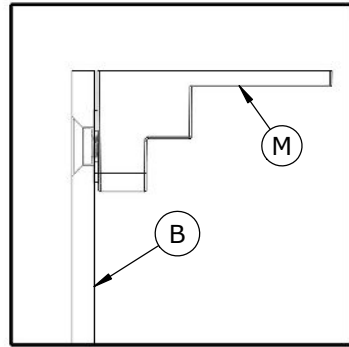
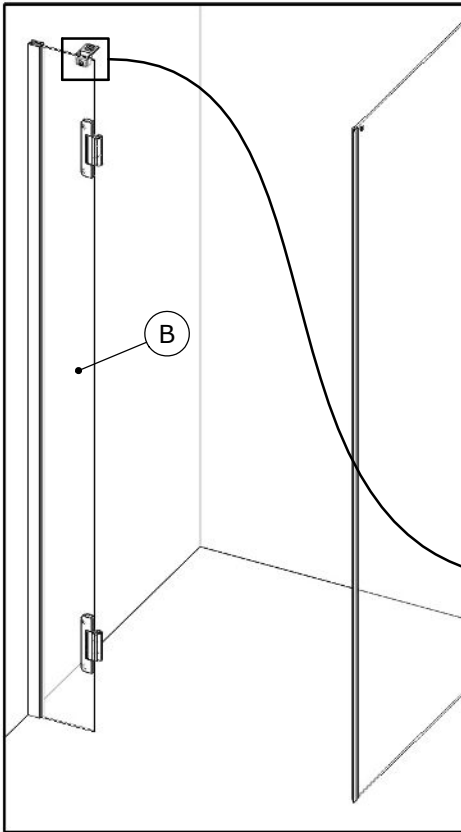

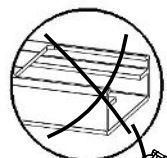
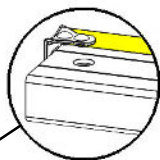
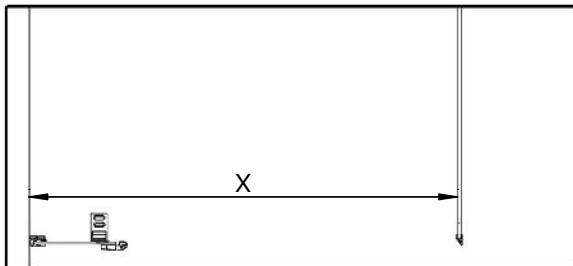
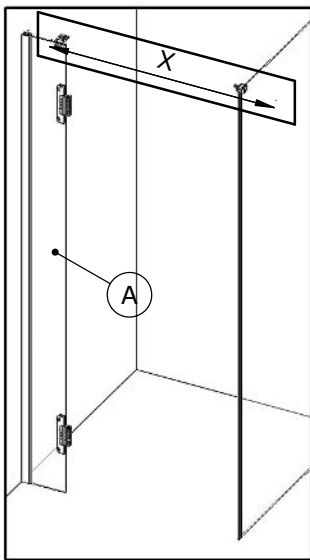

- ⓘ Attention au sens
- Ⓢ Attention to the direction
- ⓔ Atención a la dirección
- Ⓜ Attention alla direzione
- Ⓝ Let op de richting
- Ⓡ Richtung beachten

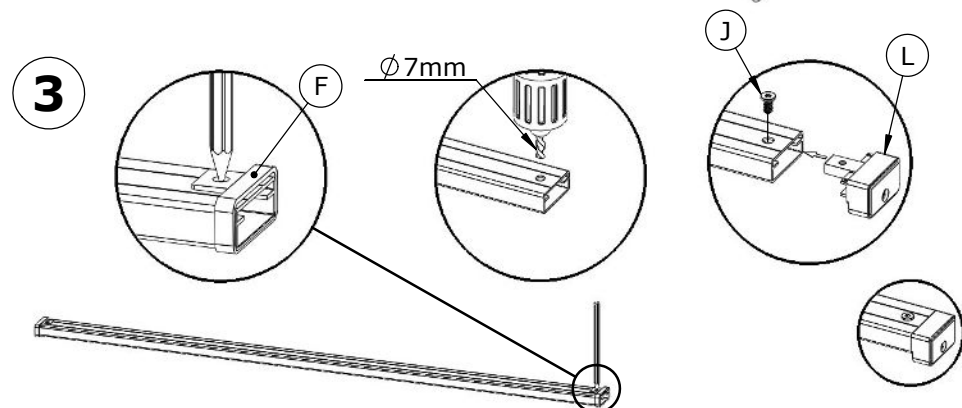
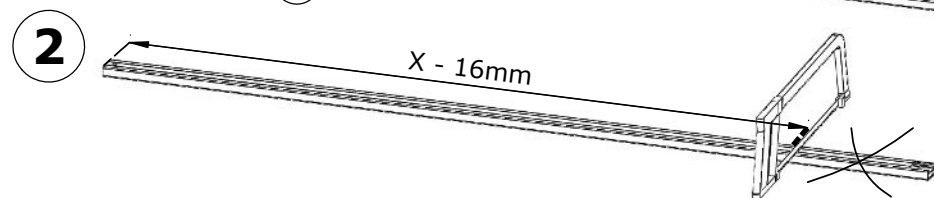
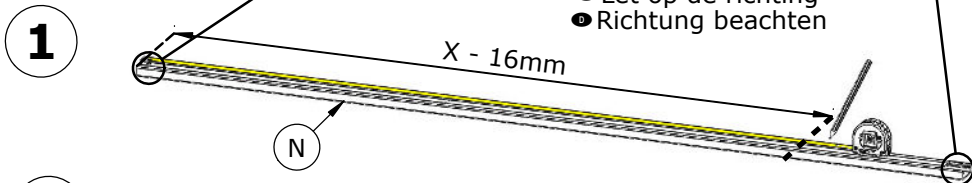

- Ⓢ Utiliser (F) comme gabarit de perçage Ⓢ Please use (F) as a drilling template
- ⓔ Utilizar (F) como plantilla de perforación Ⓜ utilizzare (F) come dima di foratura
- Ⓝ Gebruik (F) als boorsjabloon Ⓡ (F) als Bohrschablone verwenden.

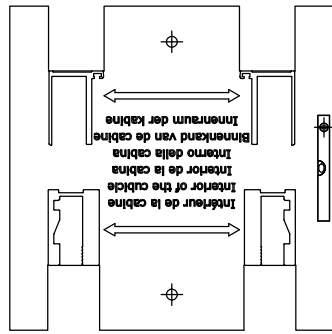
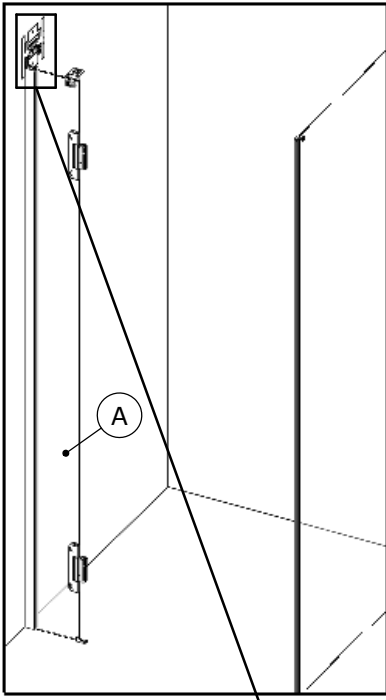

CAR342

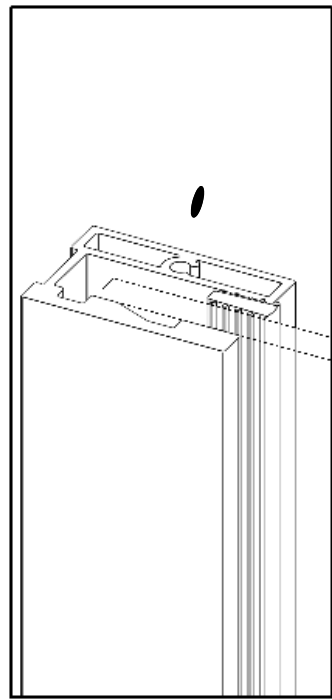
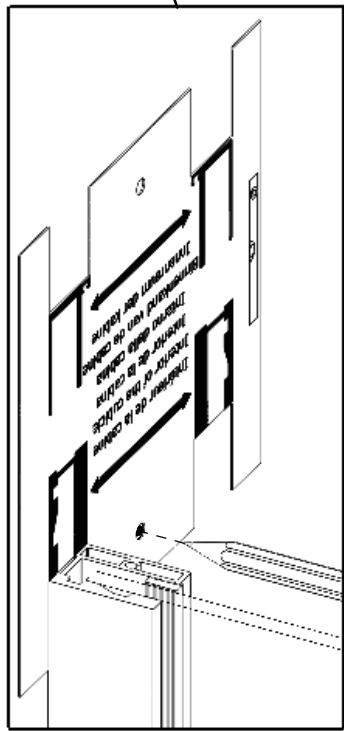

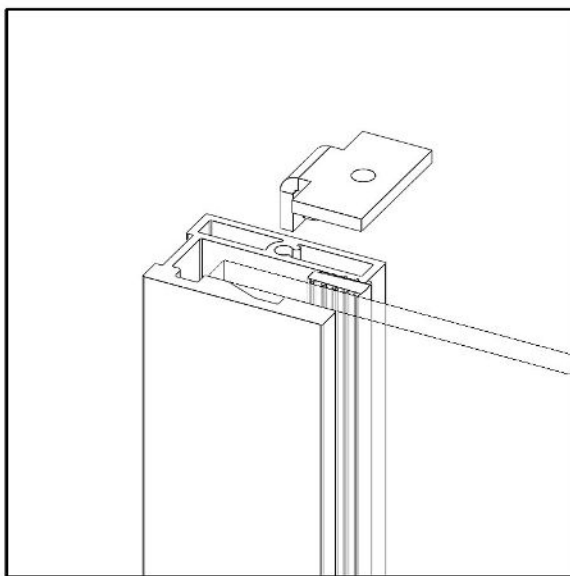
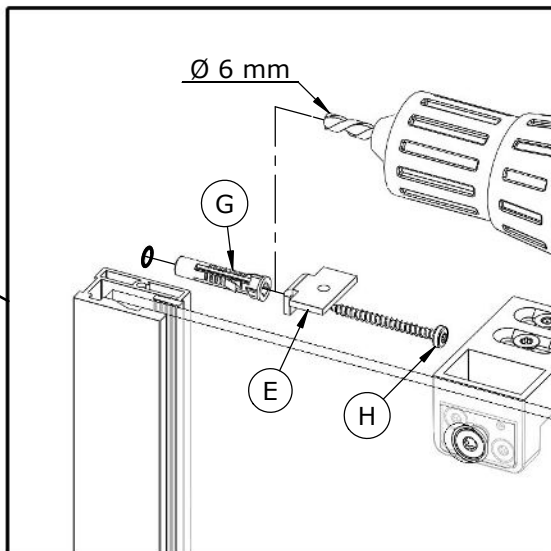
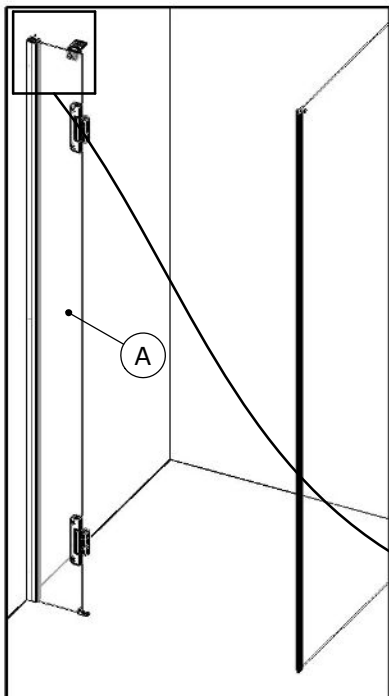

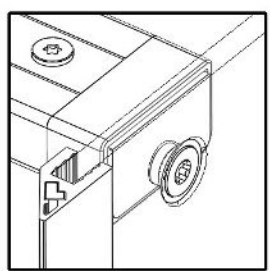
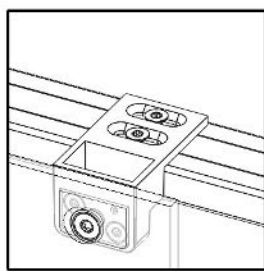
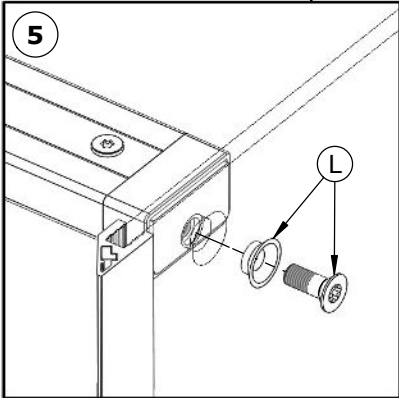
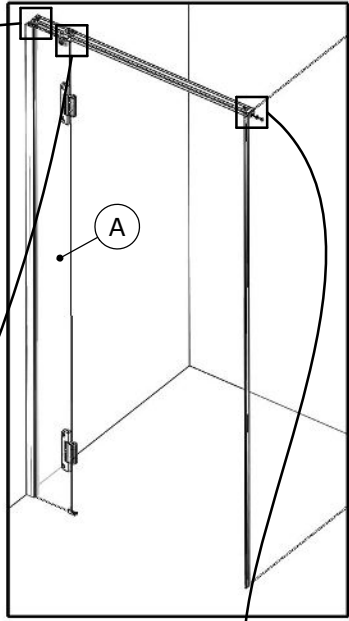
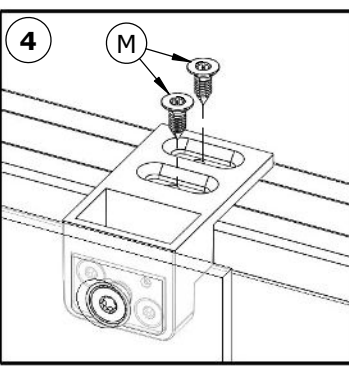
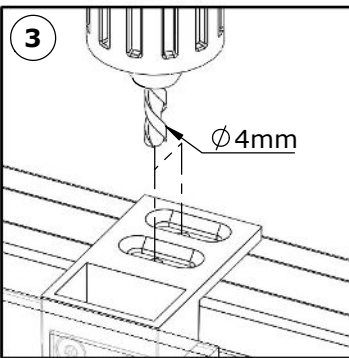
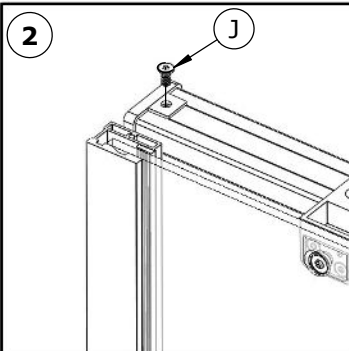
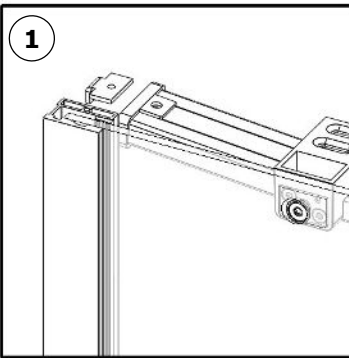

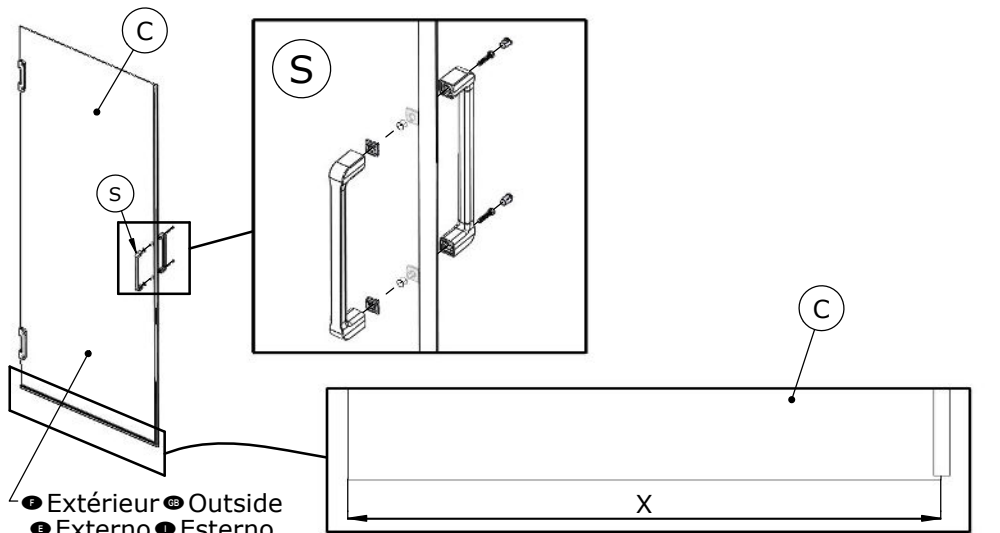

● Extérieur ● Outside
 ● Externo ● Esterno
 ● Buitenkant ● Außen

● Intérieur
 ● Inside
 ● Interior
 ● Interno
 ● Binnenkant ● Innen

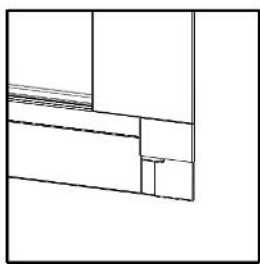
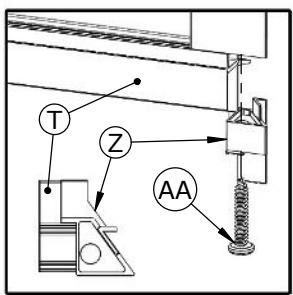
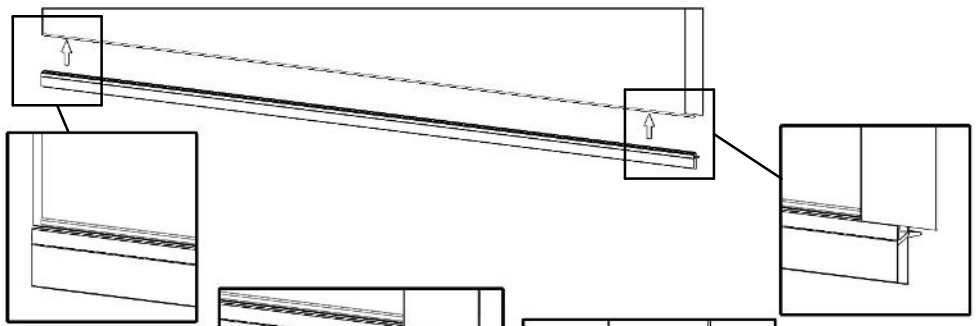
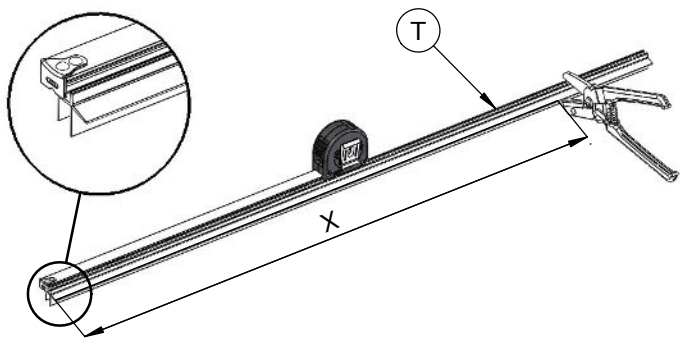

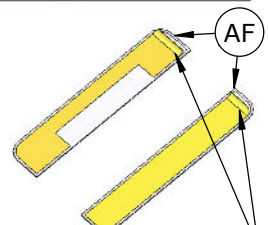
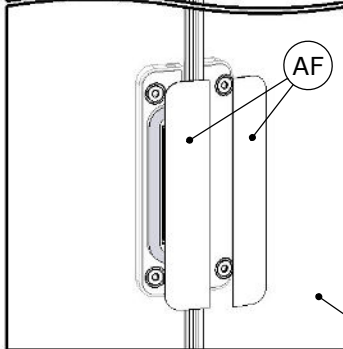
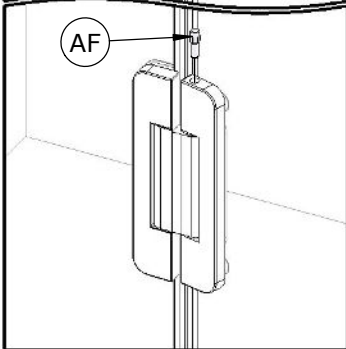
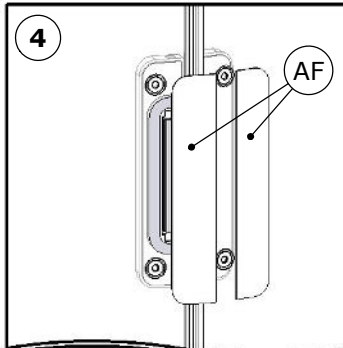
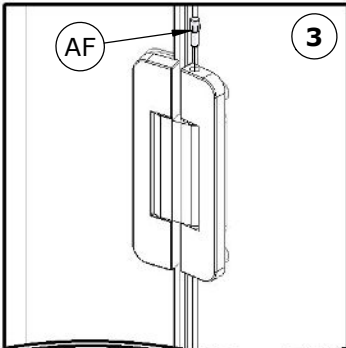
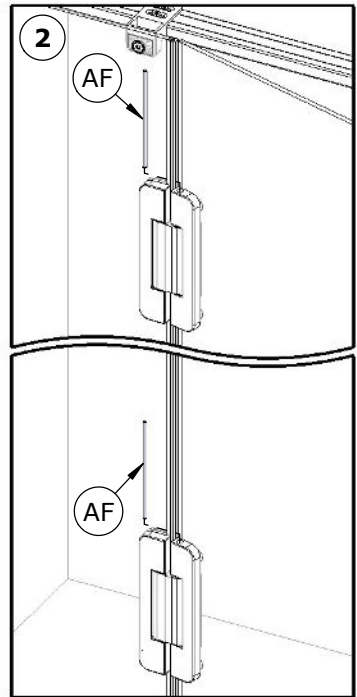
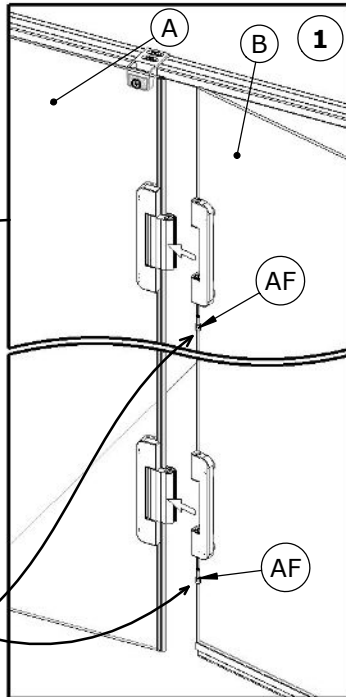
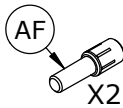
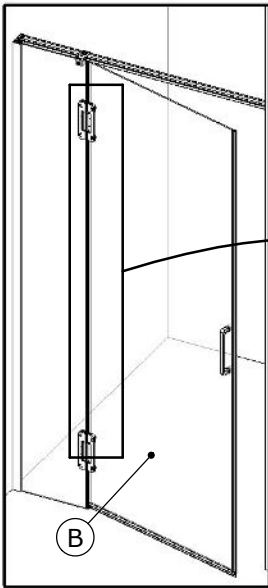

- Retirer l'adhésif
- Remove adhesive
- Quitar el adhesivo
- Rimuovere il adesivo
- Verwijder de lijm
- Klebstoff entfernen

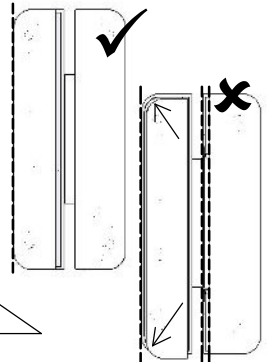

➤ Intérieur ➤ Inside ➤ Interior
➤ Interno ➤ Binnenkant ➤ Innen

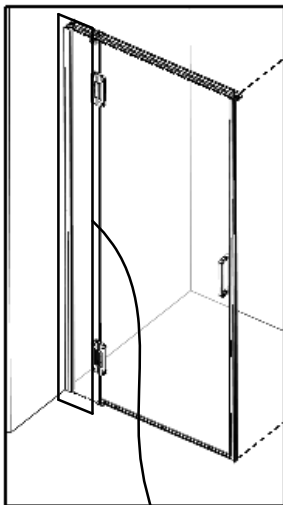

- Réglage de la porte ● Door adjustment
- Ajuste de la puerta ● regolazione porta
- Afstellen van de deur ● Einstellen der Tür

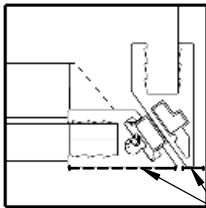

- Alignement
- Alignment
- Alineación
- Allineamento
- Uitlijning
- Verlängerung

- Si nécessaire, desserrer, régler puis resserrer
- If necessary, loosen, adjust and tighten
- Si es necesario, afloje, ajuste y apriete
- Se necessario, allentare, regolare e stringere
- Draai los, indien nodig, stel af en draai vervolgens weer vast
- Falls erforderlich, lösen, einstellen und wieder festziehen

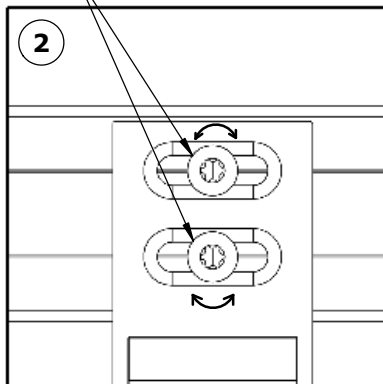
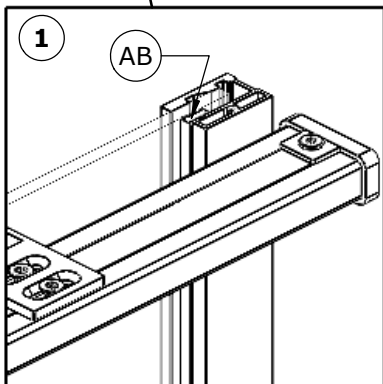

- Retirer (AB) ● Remove (AB) ● Quitar (AB)
- Togliere (AB) ● Verwijderen (AB) ● Entfernen (AB)

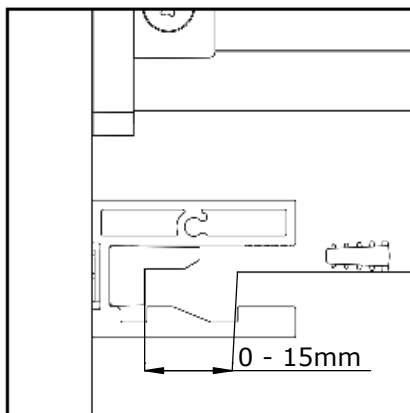
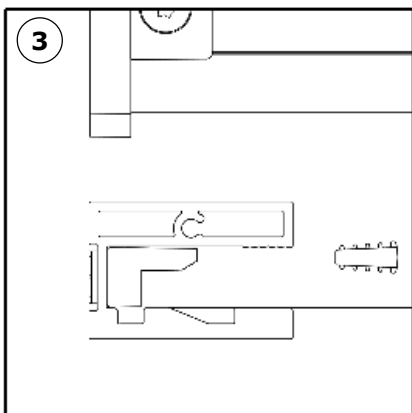

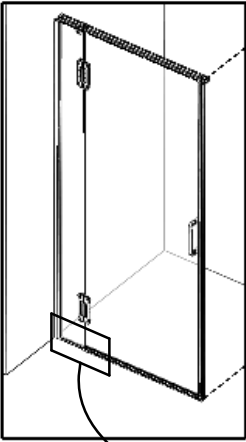

P.24

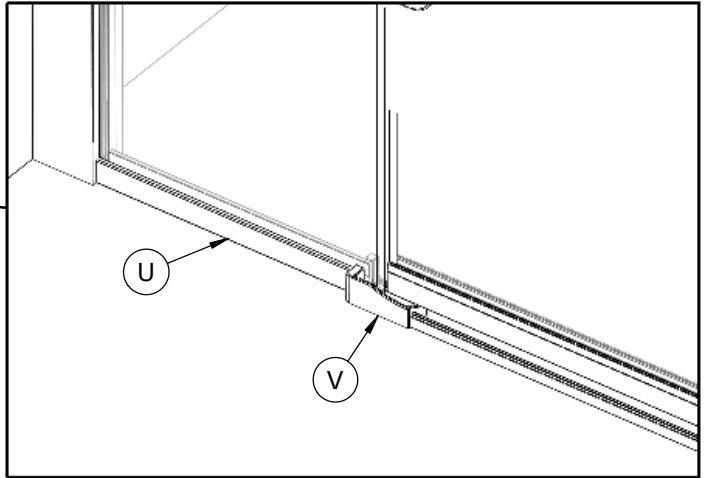
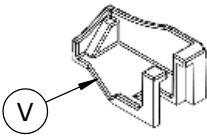

F Ou GB Or E O
I O NL Of D Oder

P.25

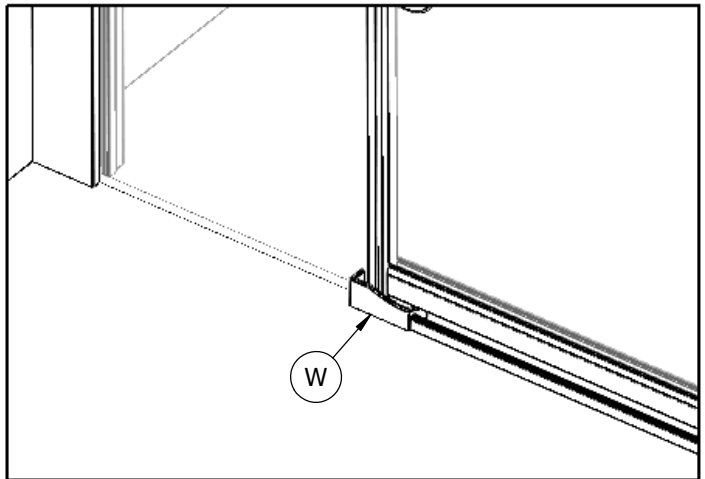
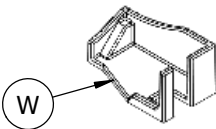

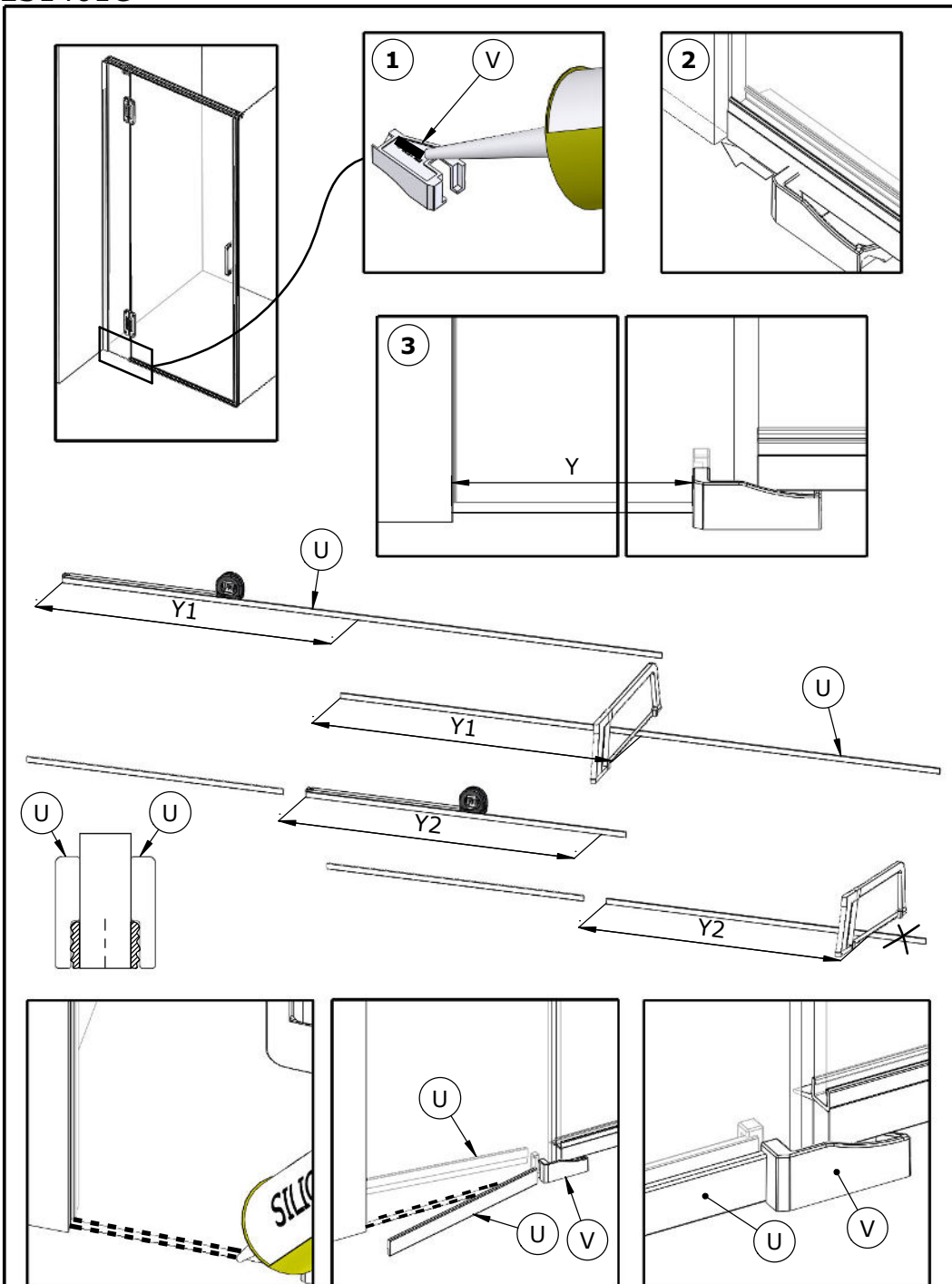

- Silicone à l'intérieur et à l'extérieur ● Silicone inside and outside
- Silicona por dentro y por fuera ● silicone all'interno e all'esterno
- Silicone aan de binnen- en de buitenkant ● Silikon innen und außen

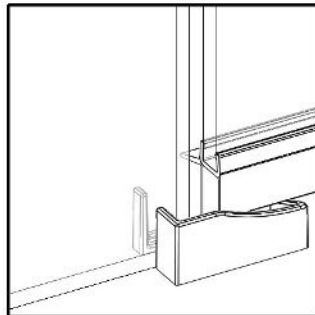
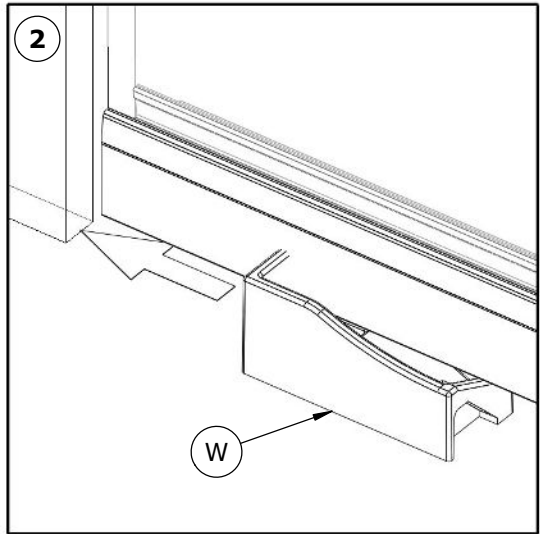
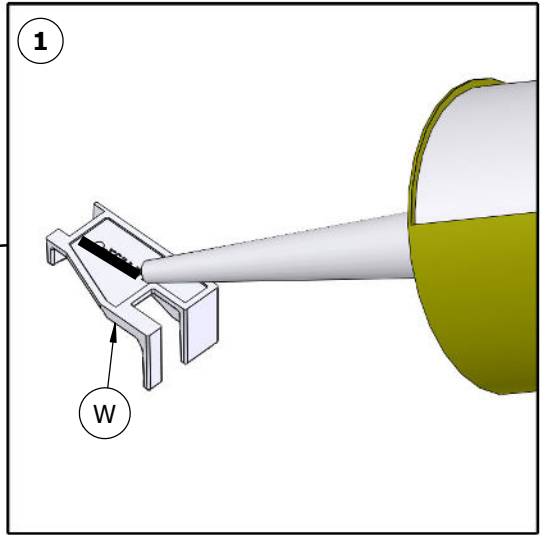
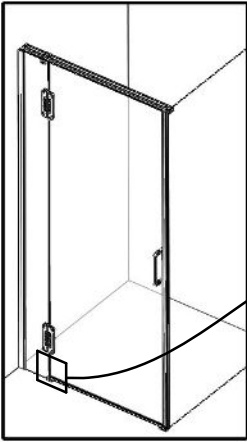

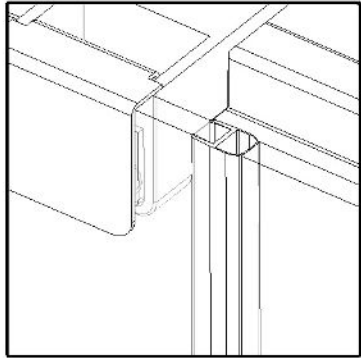
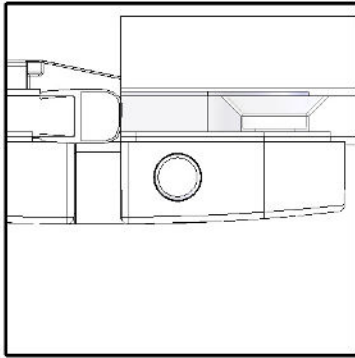
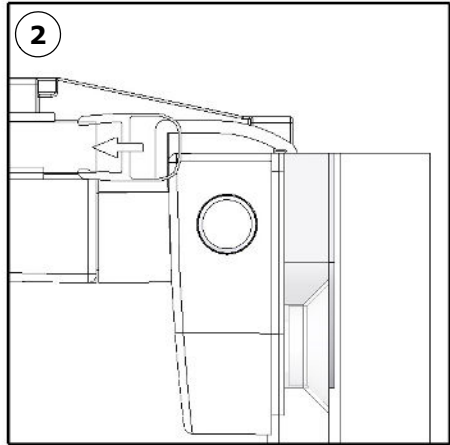
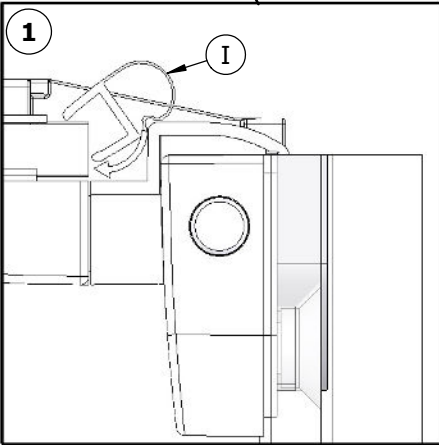
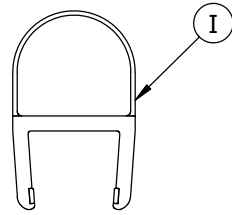
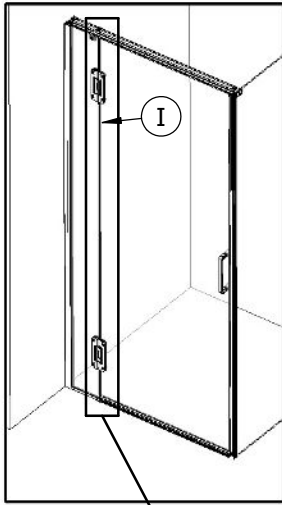

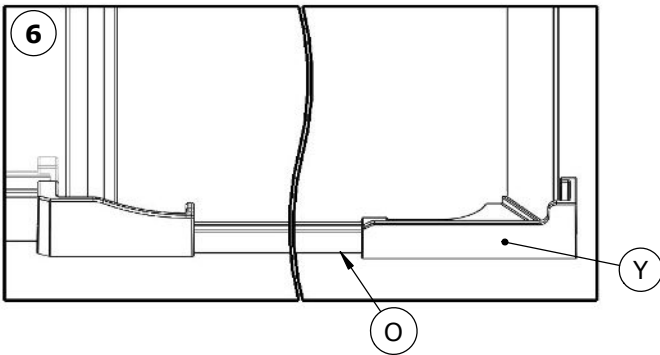
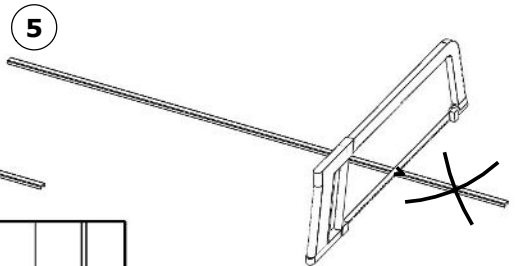
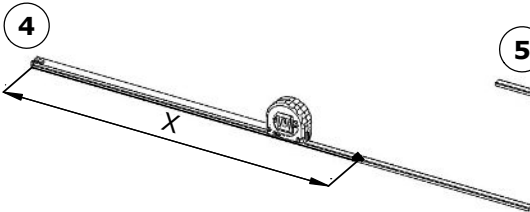
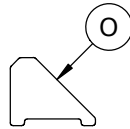
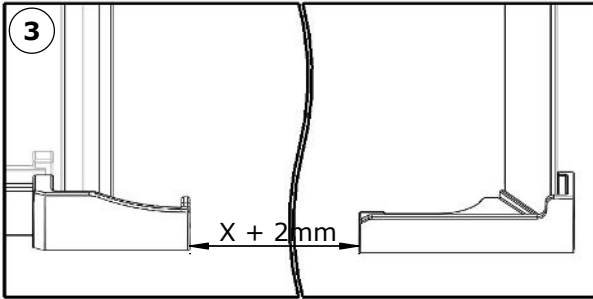
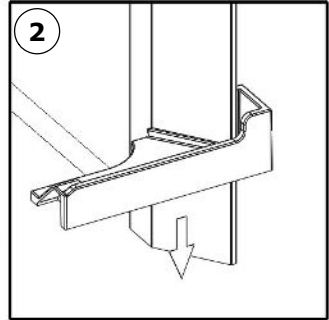
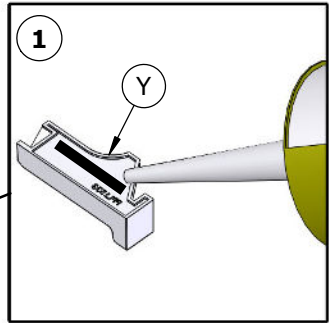
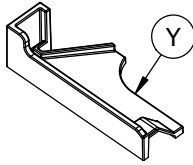
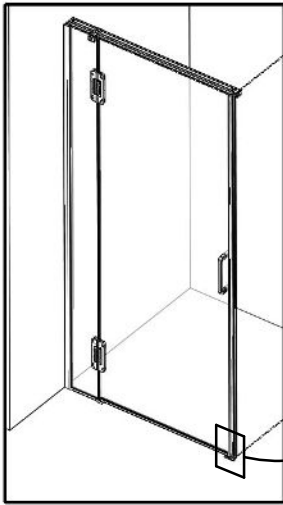

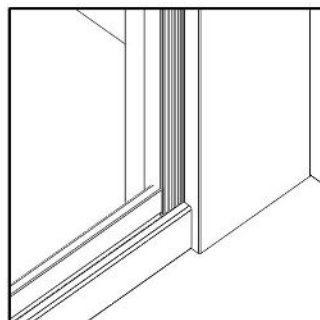
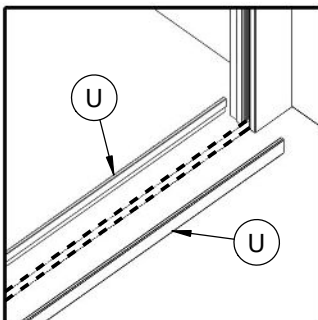
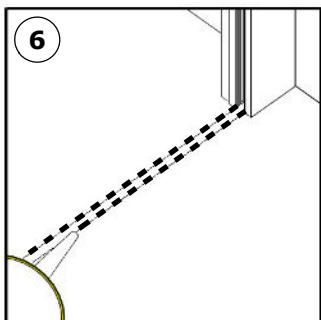
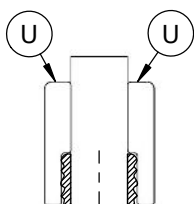
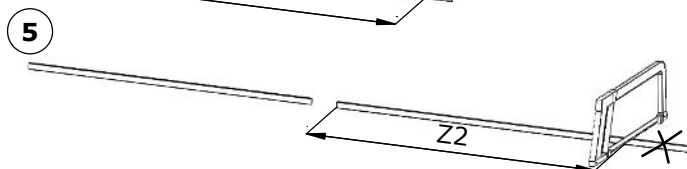
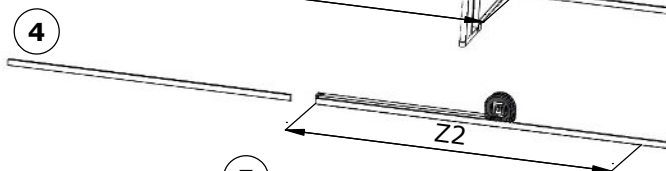
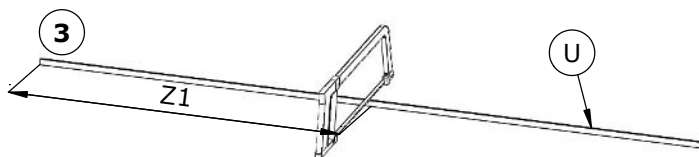
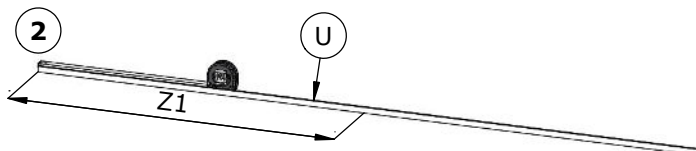
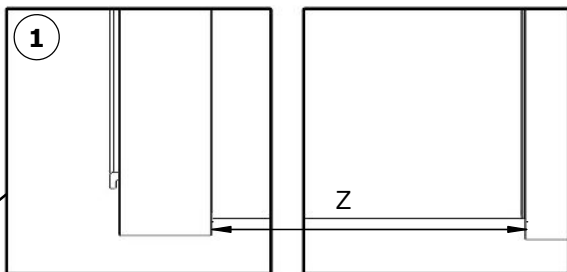
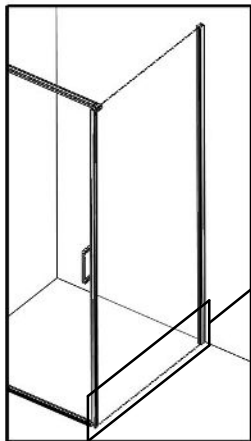

- Silicone à l'intérieur et à l'extérieur ● Silicone inside and outside
- Silicona por dentro y por fuera ● silicone all'interno e all'esterno
- Silicone aan de binnen- en de buitenkant ● Silikon innen und außen

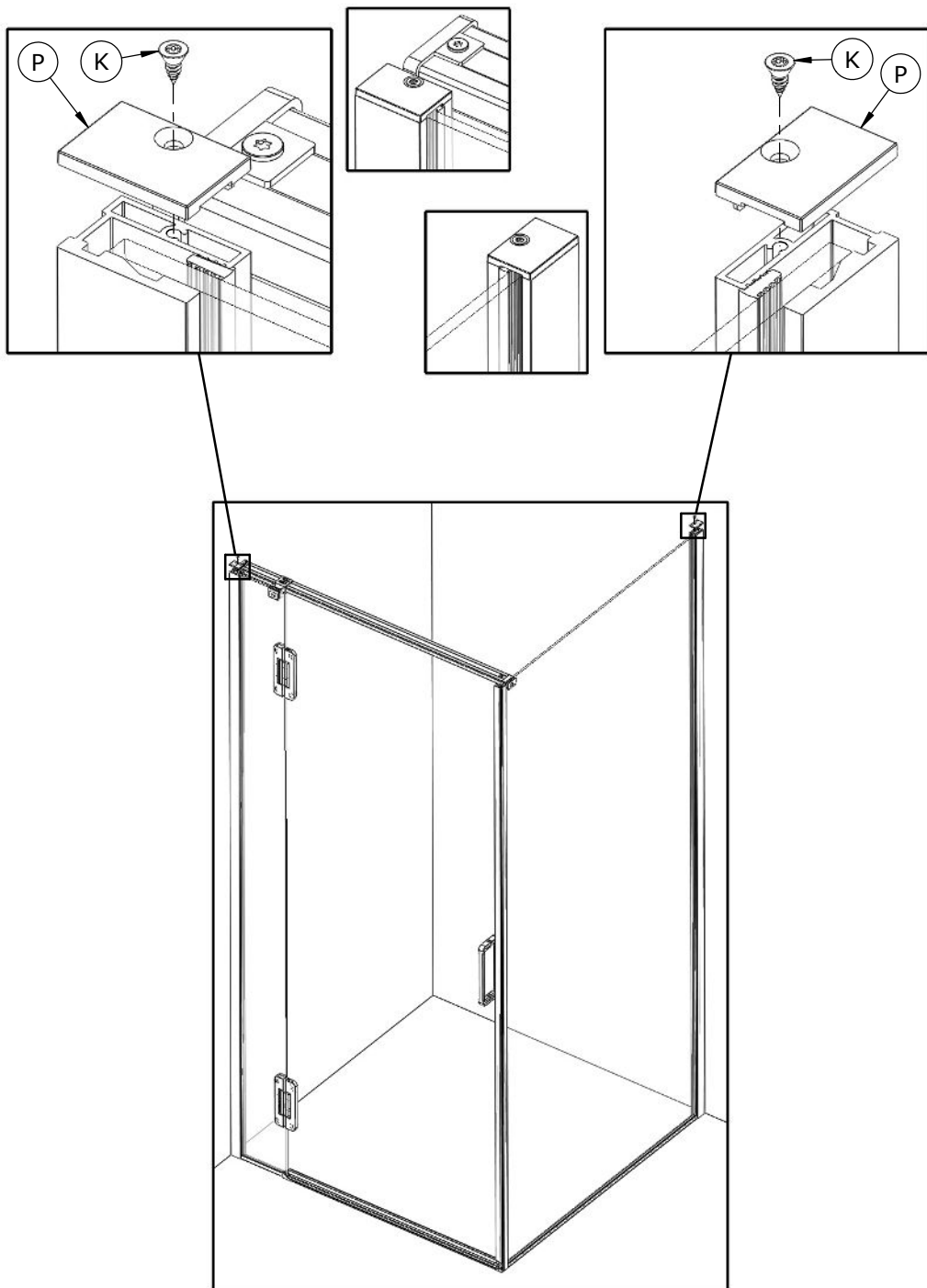

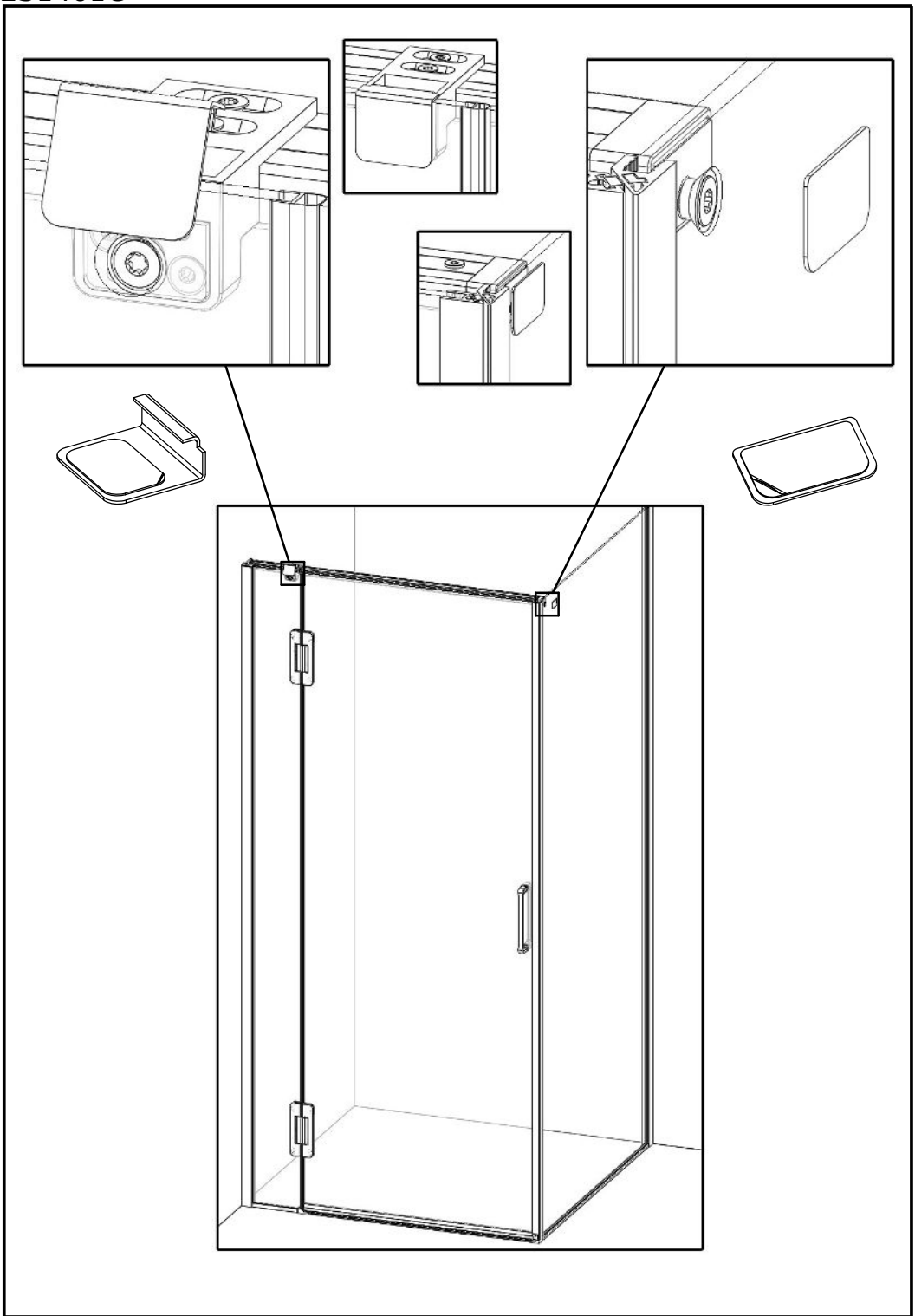

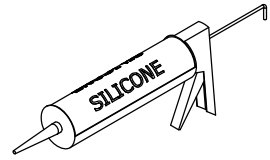
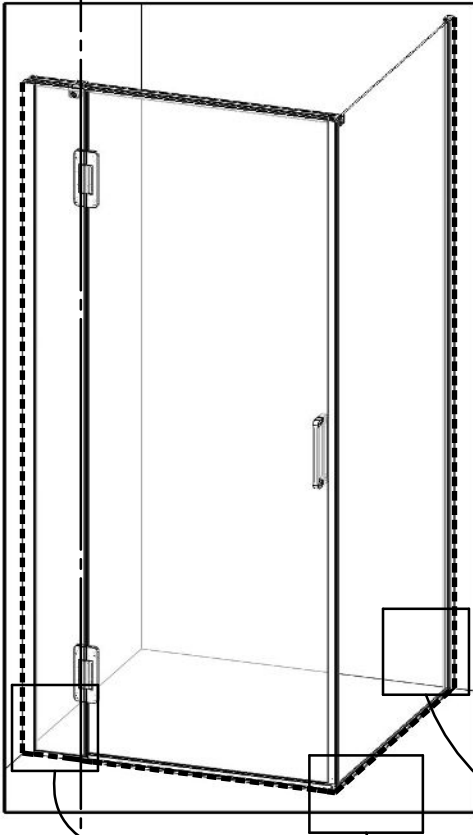

24h

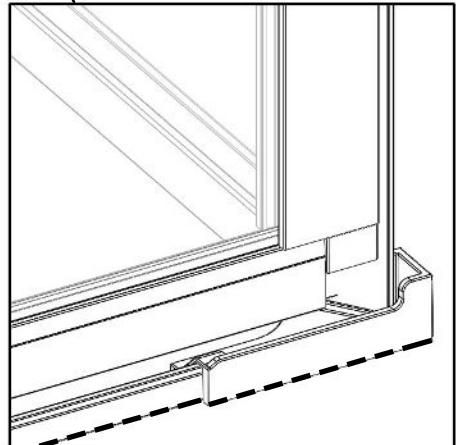
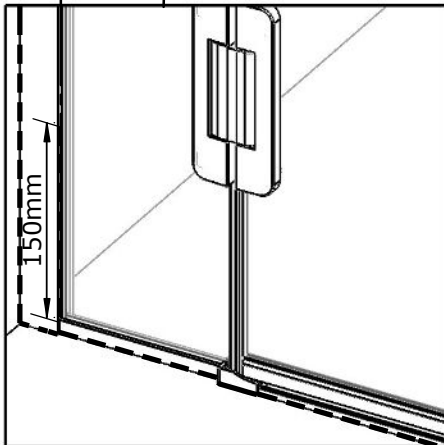
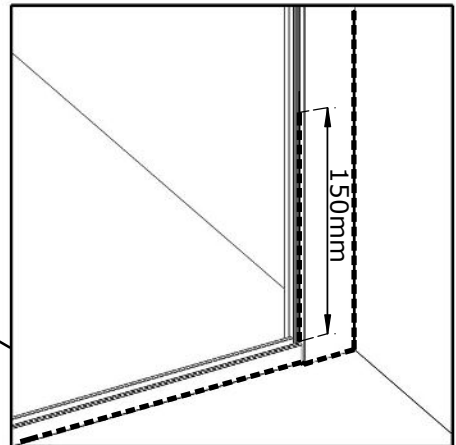



SAV
SERVICE HELPLINES
ASSISTENZA POST-VENTITA
SERVICIO POSTVENTA

FRANCE

02 40 21 29 45

UK

020 8842 0033

IRELAND

04697 33102

DEUTSCHLAND

+49 (0) 6074 / 30928 0

ITALIA

(0382) 6181

OSTEREICH

+43 1 710 60 70

SCHWEIZ

(01) 748 17 44

ESPANA

93 544 60 76

NEDERLAND

+31 475 487 100

BELGIE

+31 475 487 100

BELGIQUE

+31 475 487 100

РОССИЯ

963 19 40, 773 67 22



AQUAPRODUCTION, Site industriel,
 F - 44680 Chaumes-en-Retz

20

EN 14428

Paroi de douche, fabriquée en verre de silicate
 sodo-calcique de sécurité trempé thermiquement

Aptitude au nettoyage : réussite

Résistance à l'impact/propriétés de fragmentation : réussite

Durabilité : réussite