

- F Notice de montage ● GB Installation instructions
- E Manual de instalación ● I Istruzioni di montaggio
- NL Montage-instructies ● D Montageanleitung

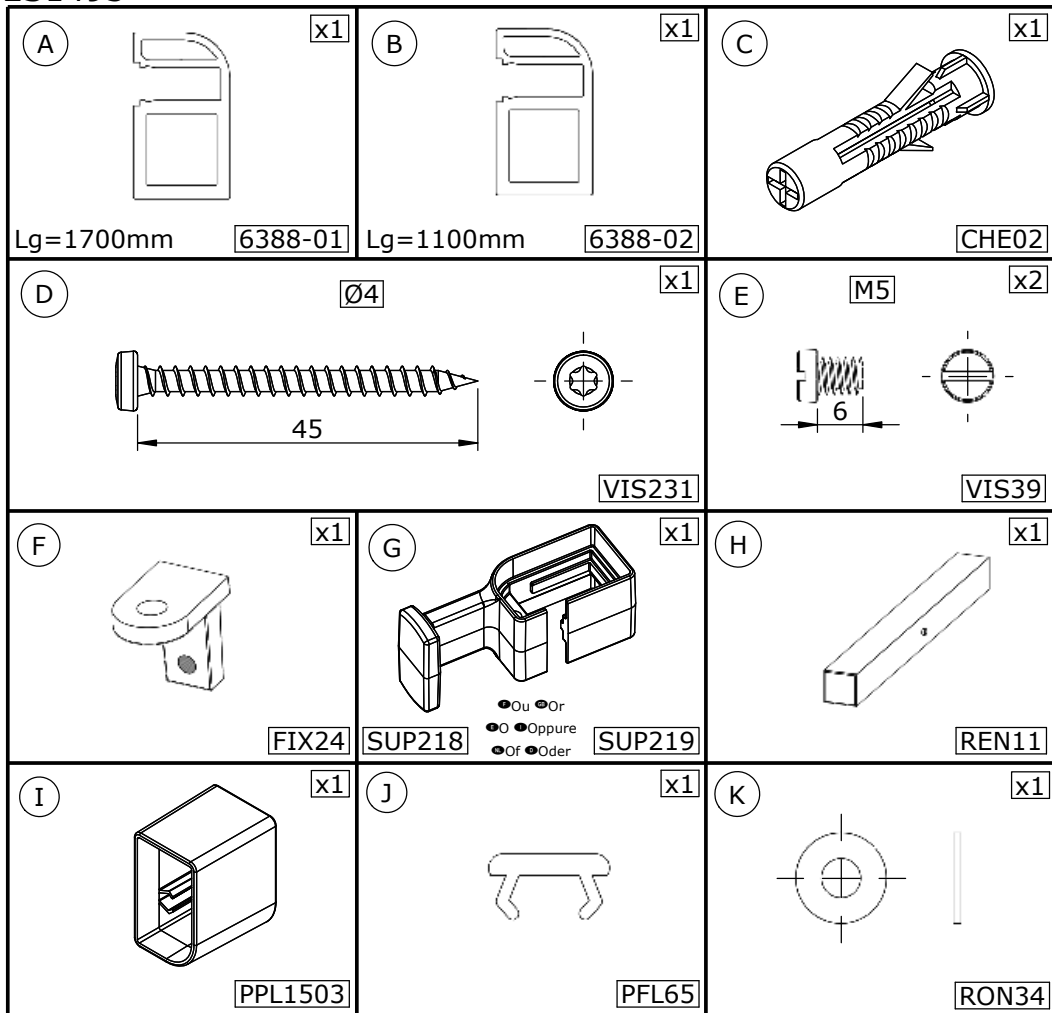

- Attention aux étapes :
- GB Check installation steps :
- E Atención a los pasos :
- I Attenzione ai passi :
- NL Aandacht voor de stappen :
- D Achtung vor den Schritten :

P4 - 7 - 13



- Les quantités données sont les quantités utiles au montage. les sachets fournis contiennent des pièces supplémentaires.
- The quantities given are what are required for the installation. There may be some surplus in the package provide.
- Las cantidades indicadas son las cantidades necesarias para el montaje. Las bolsitas incluidas contienen piezas suplementarias.
- Le quantità fornite sono le quantità necessarie al montaggio. I sacchetti forniti contengono pezzi supplementari.
- De aangegeven aantallen zijn vereist voor de montage. De verpakking bevat extra onderdelen.
- Die Mengenangaben beziehen sich auf die für die Montage nötigen Teile. Eventuell weitere beige packte Teile ignorieren.

● Outillage nécessaire ● Tools required ● Equipamiento necesario
 ● Attrezzatura necessaria ● Benodigde gereedschap ● Werkzeuge erforderlich

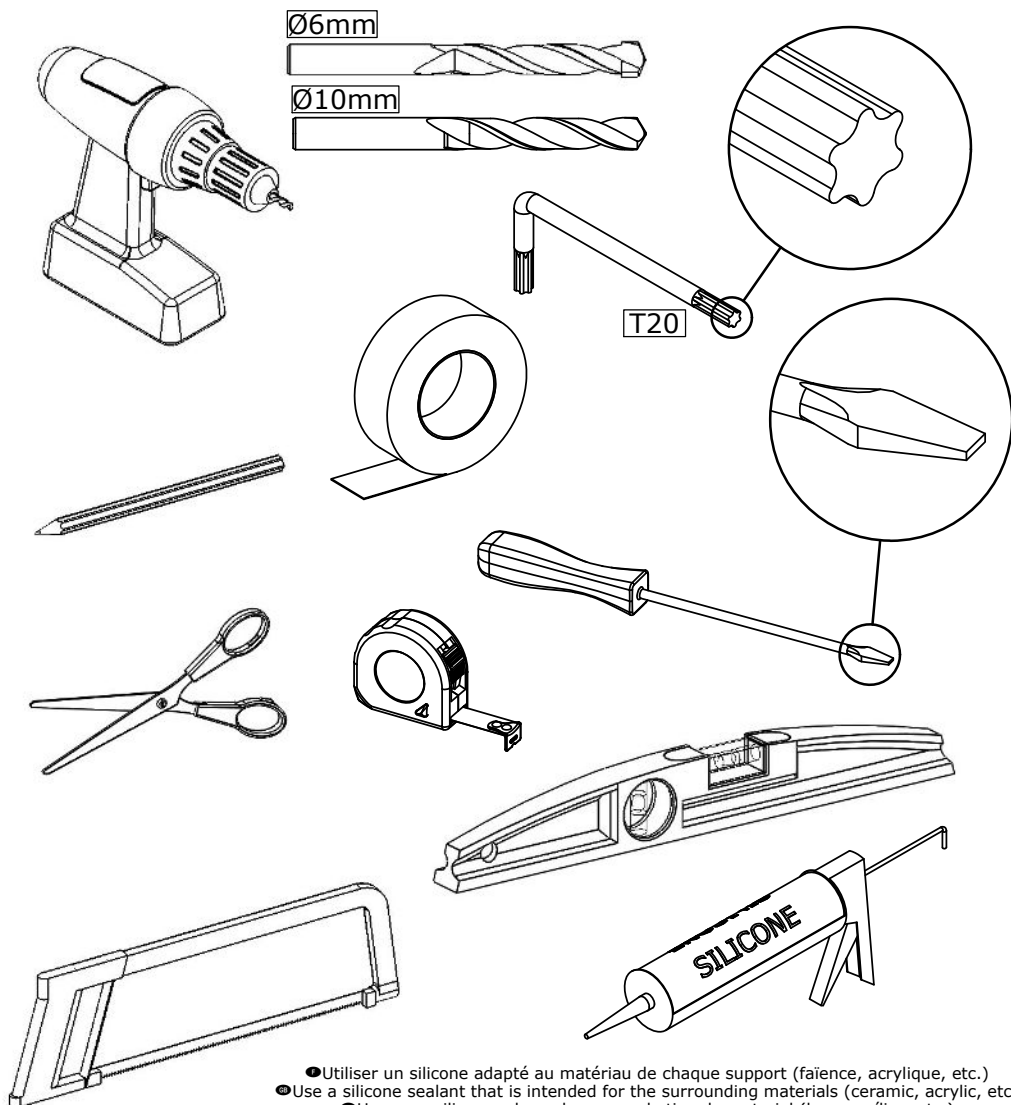

- Utiliser un silicone adapté au matériau de chaque support (faïence, acrylique, etc.)
- Use a silicone sealant that is intended for the surrounding materials (ceramic, acrylic, etc.)
 - Usar una silicona adecuada para cada tipo de material (loza, acrílico, etc.)
 - Utilizzare un silicone adatto a qualsiasi materiale (ceramica, acrilico, ecc.)
 - Gebruik siliconenkit die geschikt is voor iedere ondergrond (tegelwerk, acryl, etc.)
 - Für das jeweilige Trägermaterial (Stein, Acryl usw.) geeignetes Silikon verwenden.



- Montage à gauche ● Left hand
- Montaje a la izquierda
- Montaggio a sinistra
- Montage links ● Montage links

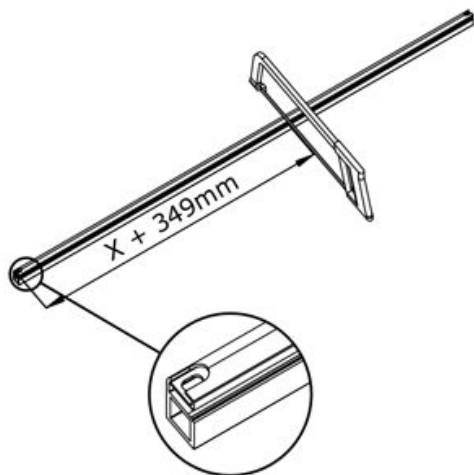
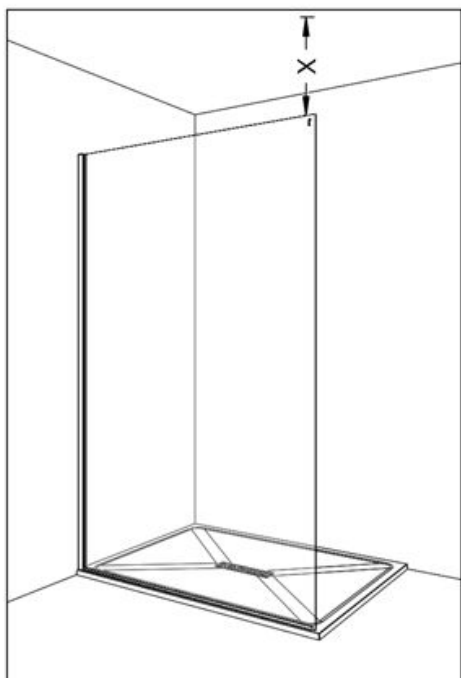

- Montage à droite ● Right hand
- Montaje a la derecha
- Montaggio a destra
- Montage rechts ● Montage rechts

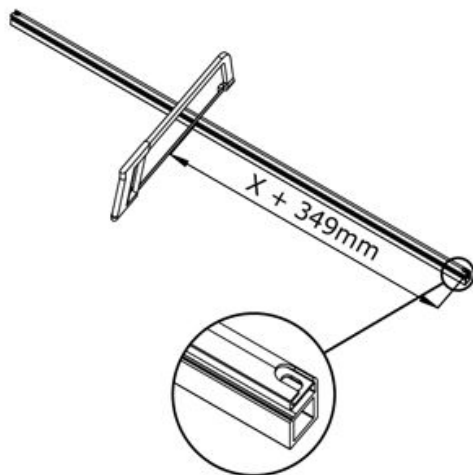
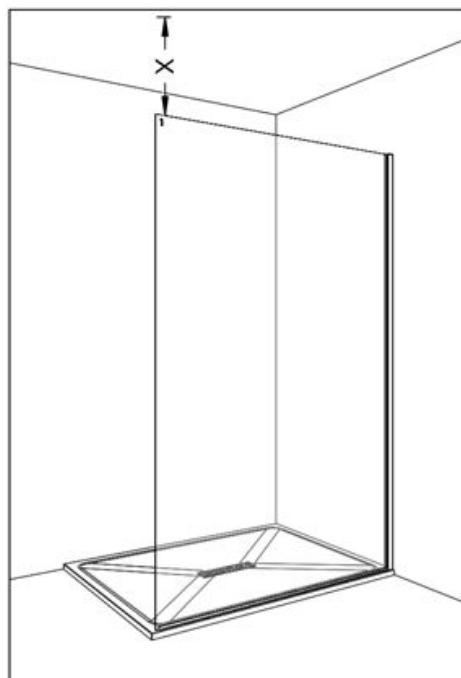

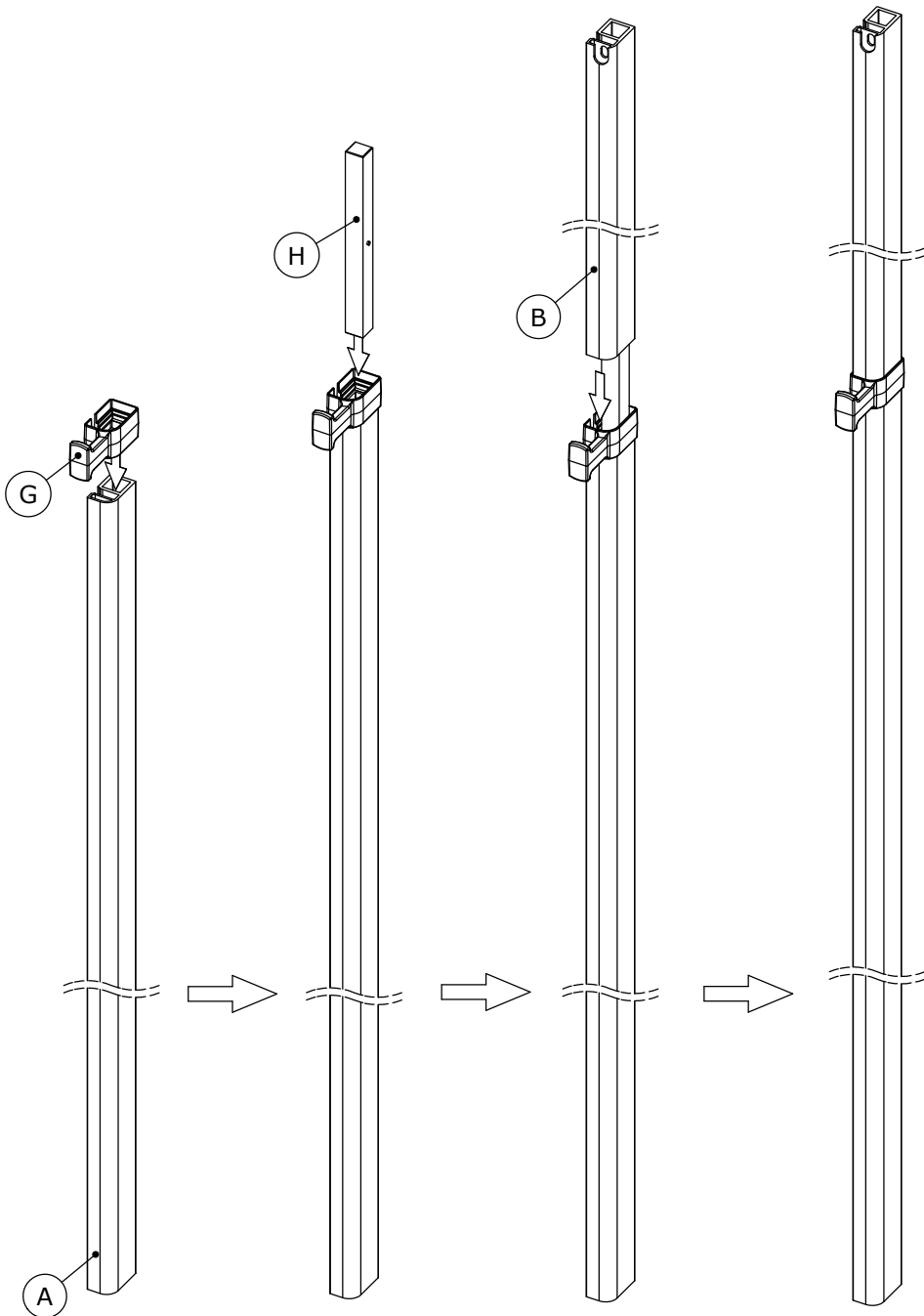

- ① Maintenir avec du ruban adhésif
- ② Hold with adhesive tape
- ③ Mantener con cinta adhesiva
- ④ Tenere con un pò di nastro adesivo
- ⑤ Houd vast met tape
- ⑥ Silikonieren Sie den Rand der Duschwanne

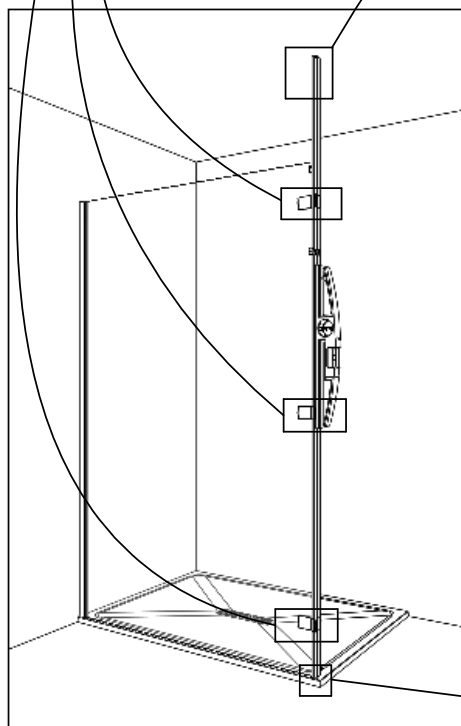
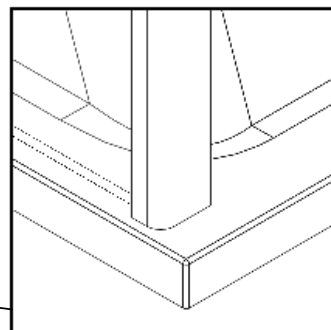
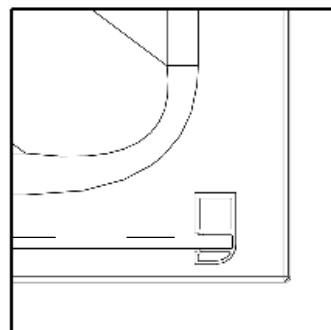
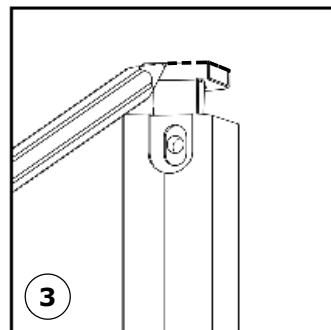
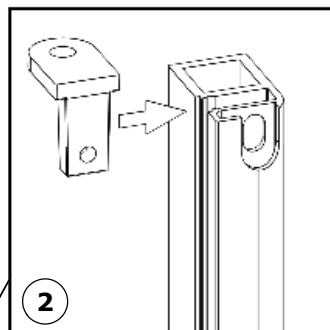
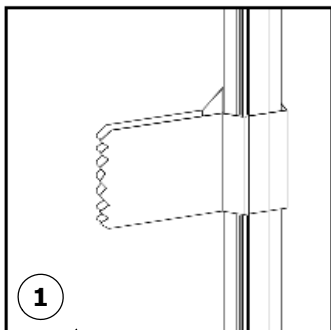

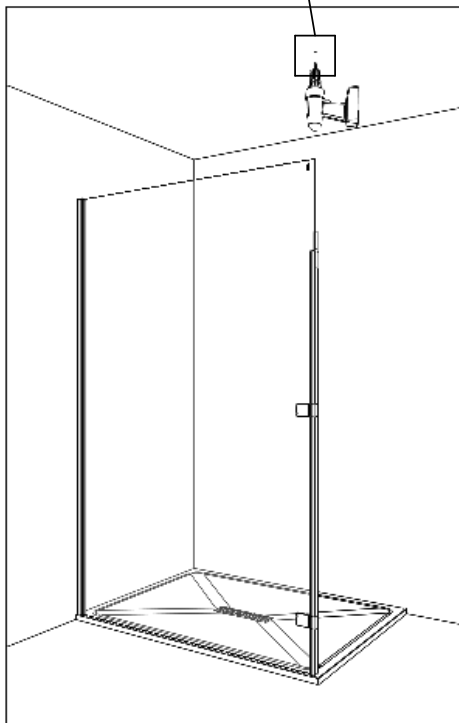
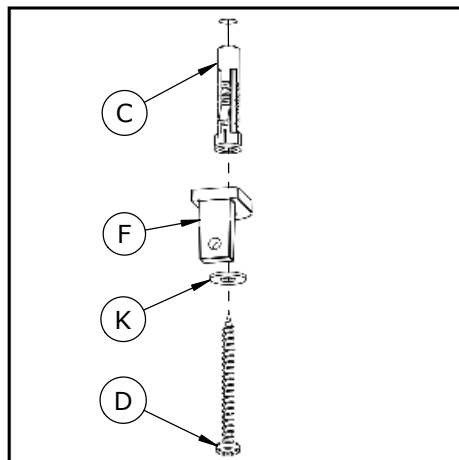
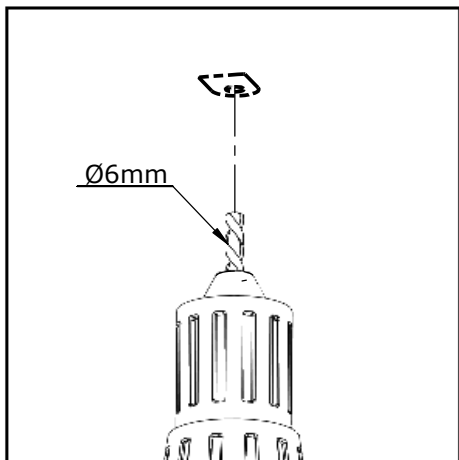

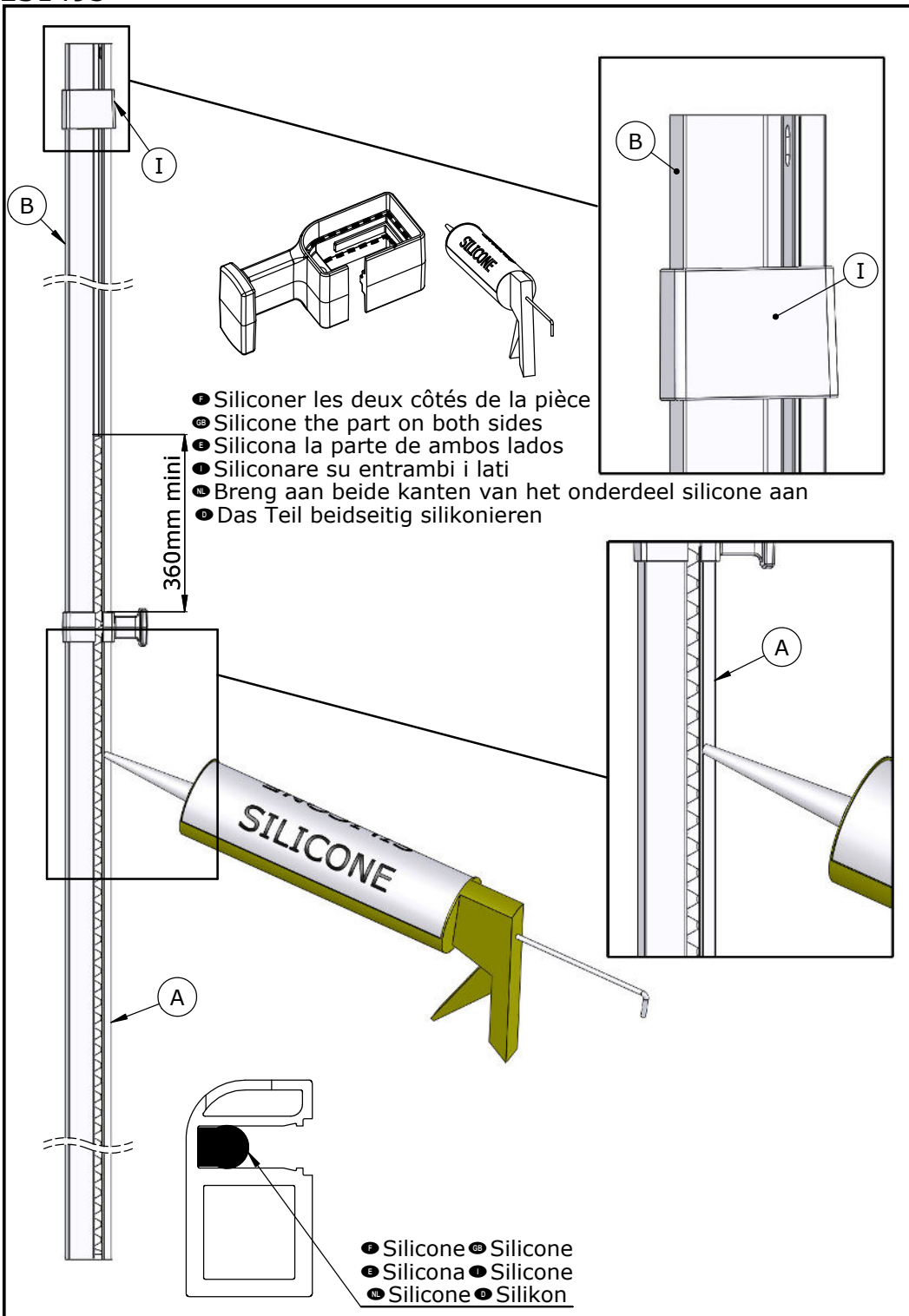

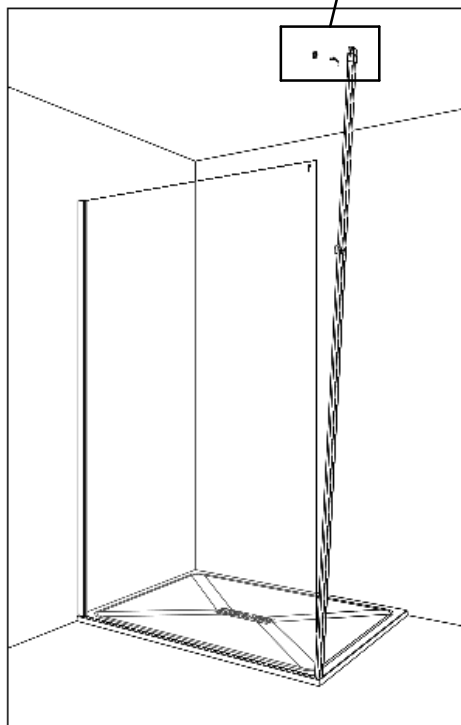
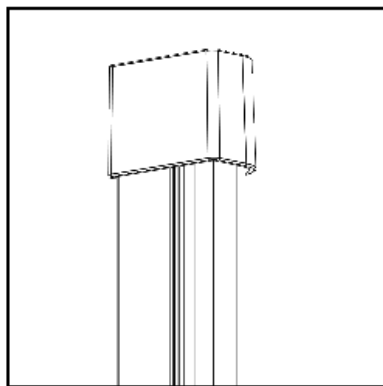
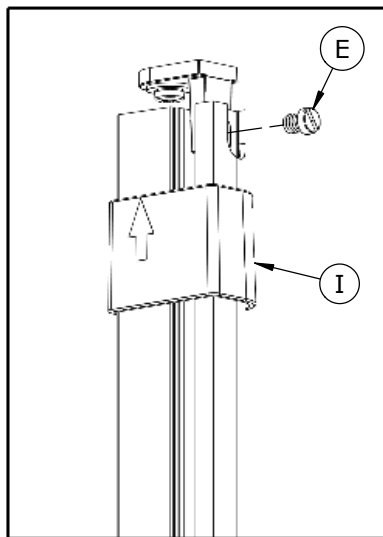
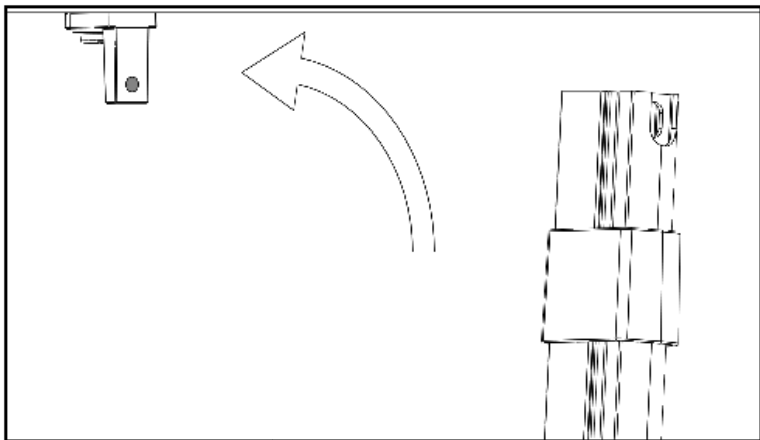

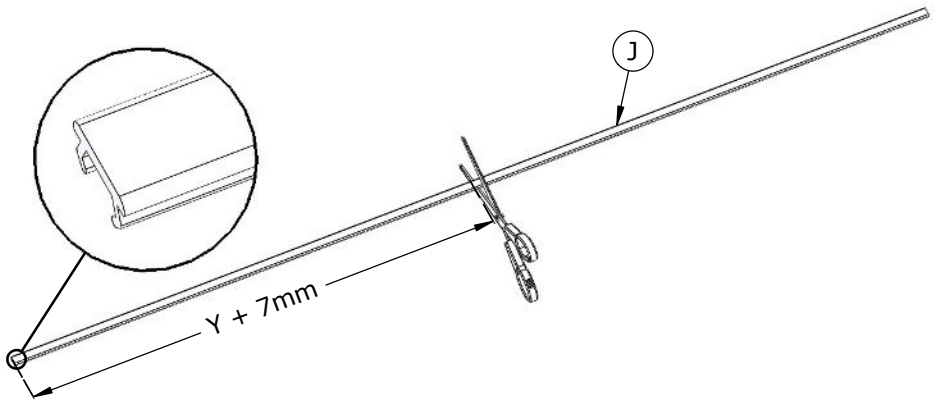
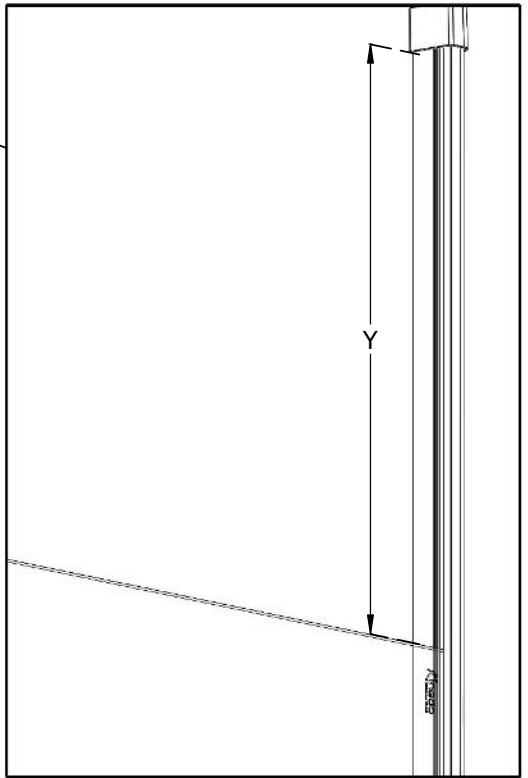
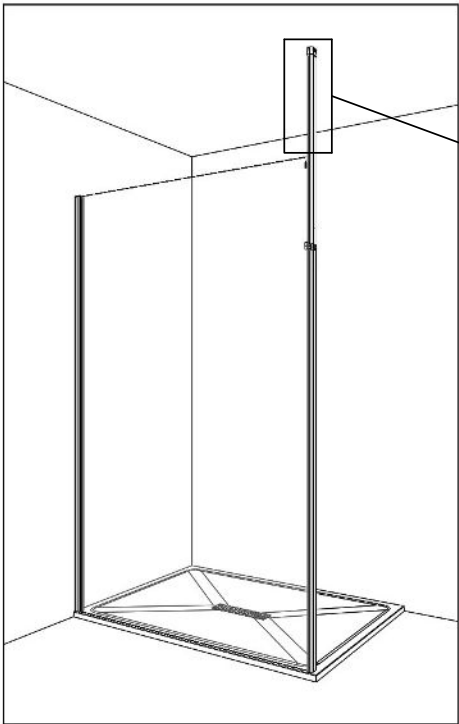

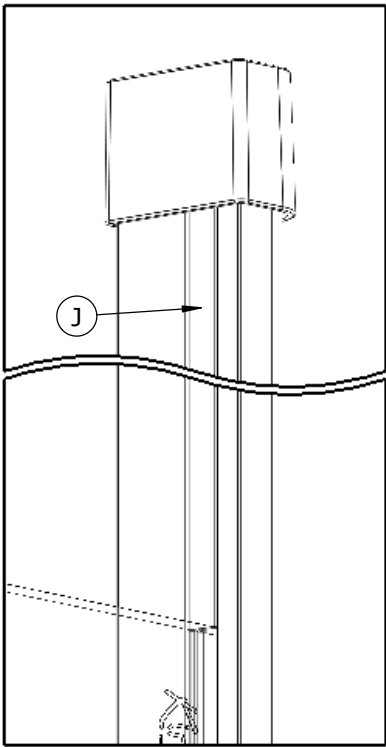
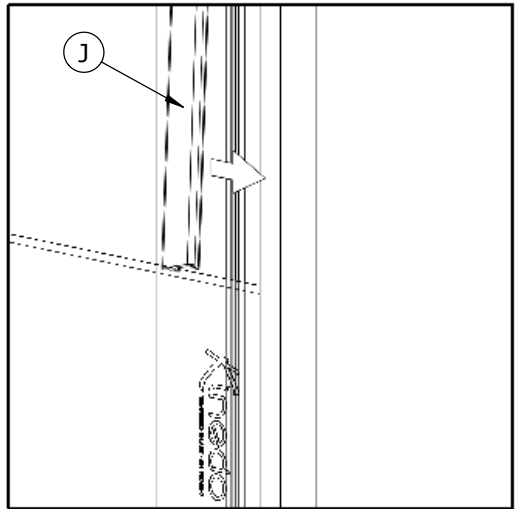
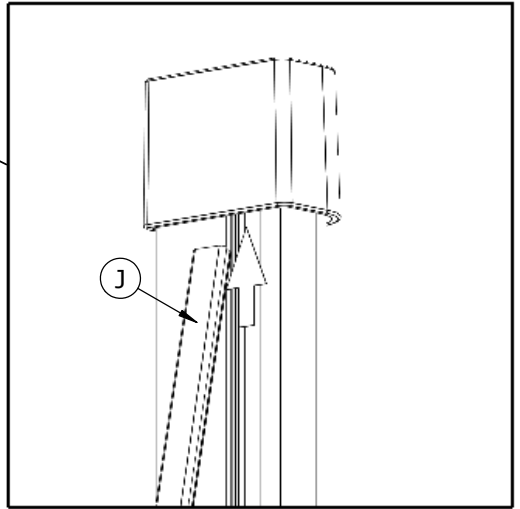
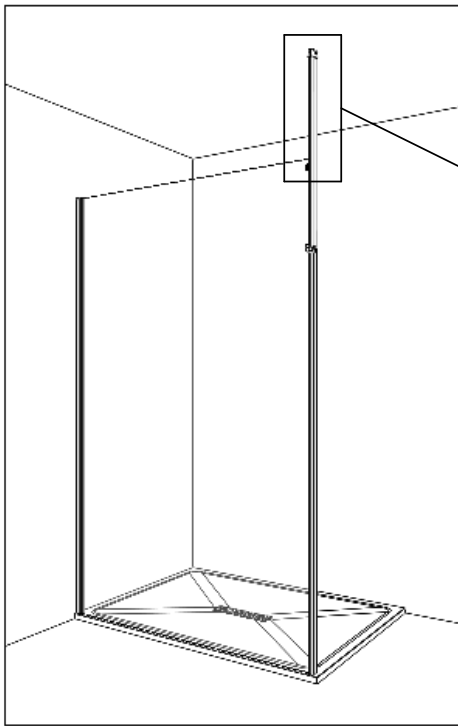

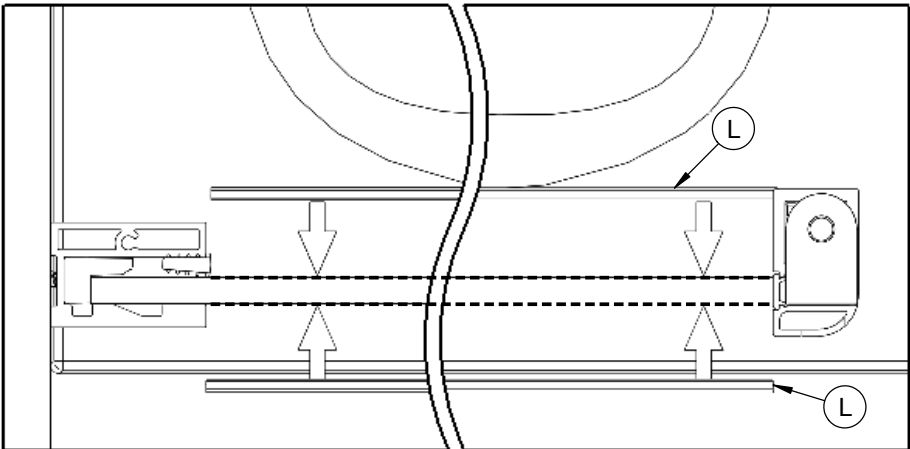
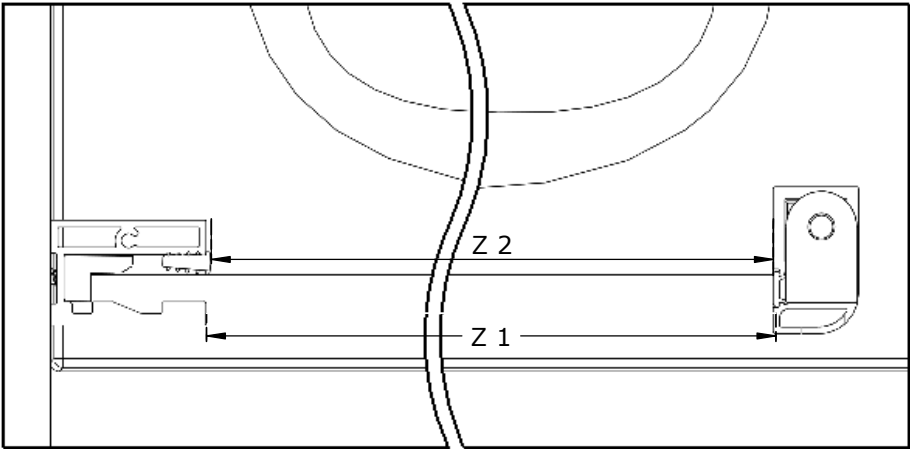
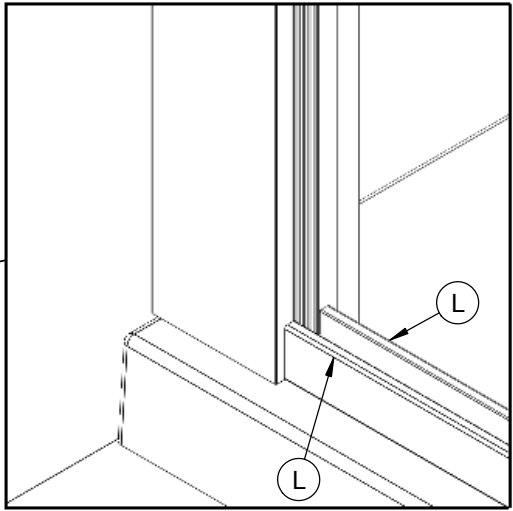
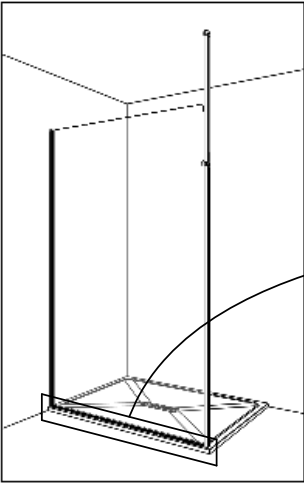

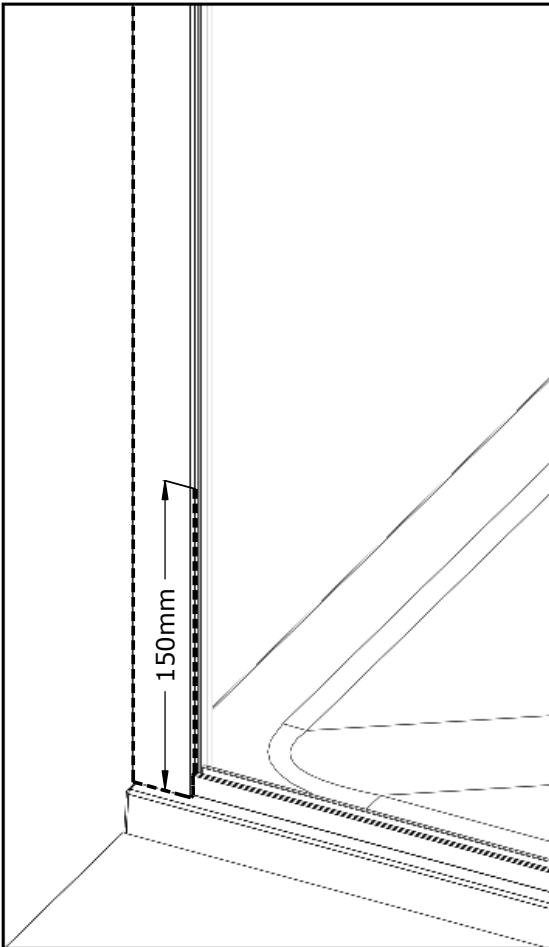
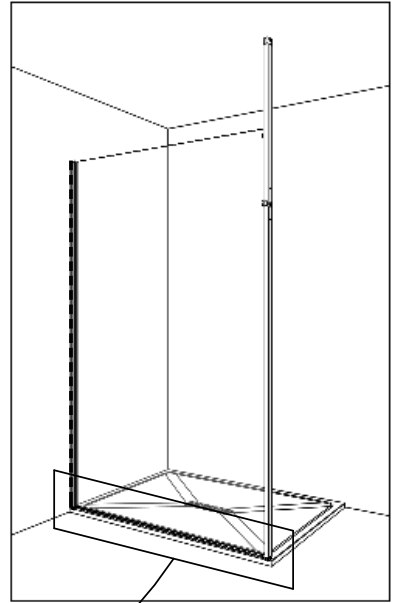
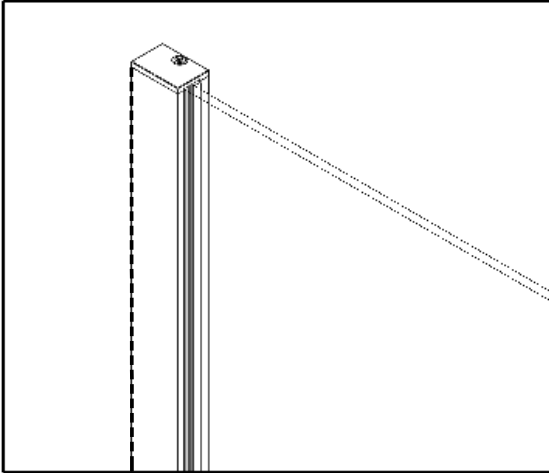

24h

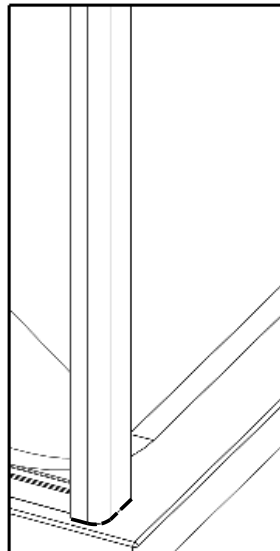



AQUAPRODUCTION, Site industriel,
F - 44680 Chaumes-en-Retz

20

EN 14428

Paroi de douche, fabriquée en verre de silicate
sodo-calcique de sécurité trempé thermiquement

Aptitude au nettoyage : réussite

Résistance à l'impact/propriétés de fragmentation : réussite

Durabilité : réussite



SAV
SERVICE HELPLINES
ASSISTENZA POST-VENDITA
SERVICIO POSTVENTA

FRANCE

02 40 21 29 45

SCHWEIZ

(01) 748 17 44

UK

020 8842 0033

ESPANA

93 544 60 76

IRELAND

04697 33102

NEDERLAND

+31 475 487 100

DEUTSCHLAND

+49 (0) 6074 / 30928 0

BELGIE

+31 475 487 100

ITALIA

(0382) 6181

BELGIQUE

+31 475 487 100

OSTEREICH

+43 1 710 60 70

РОССИЯ

963 19 40, 773 67 22