

- F Notice de montage ● GB Installation instructions
- E Manual de instalación ● I Istruzioni di montaggio
- NL Montage-instructies ● D Montageanleitung

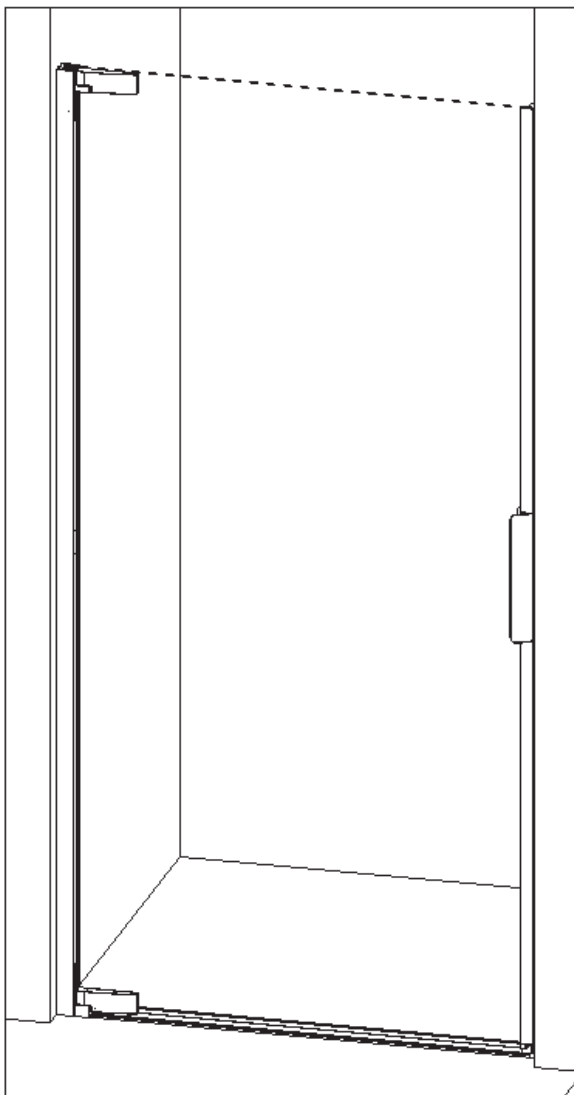

- F Attention aux étapes :
- GB Check installation steps :
- E Atención a los pasos :
- I Attenzione ai passi :
- NL Aandacht voor de stappen :
- D Achtung vor den Schritten :

P. 8 - 12 - 17

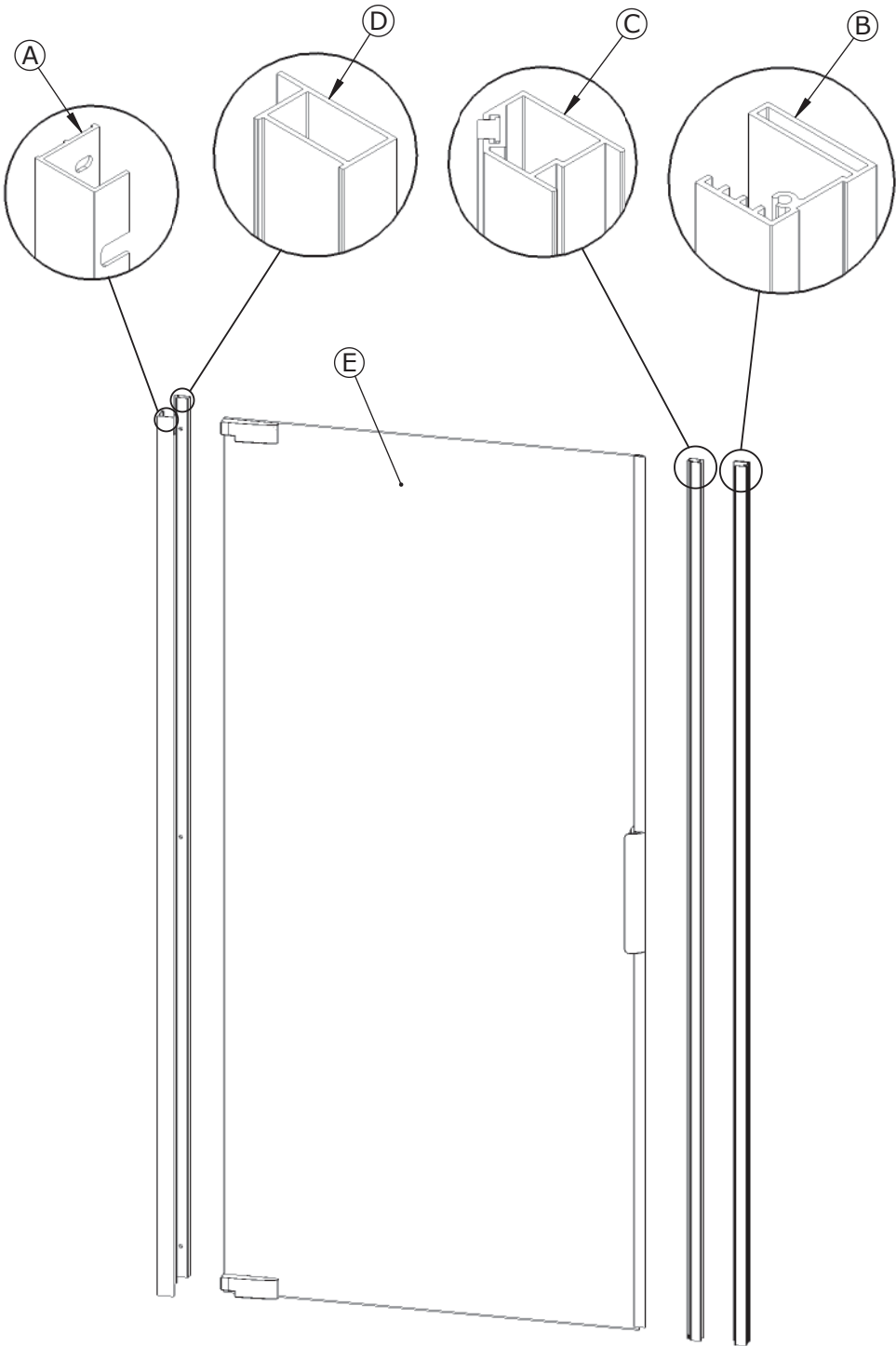

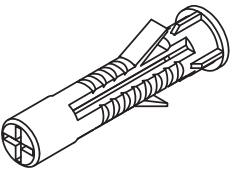

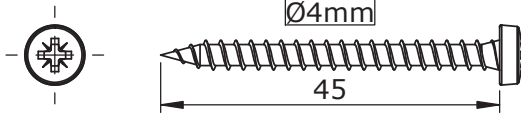
(F) X8

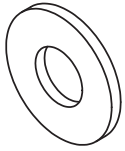
 CHE02

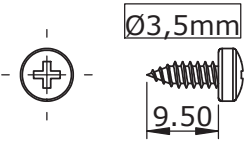
(G) X8

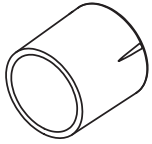
 1 = 1
 VIS210

(H) X8

 RON34

(I) X3

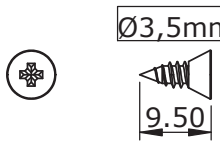
 1 = 1
 VIS01

(J) X3

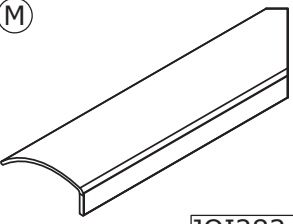
 PPL1075

(K) X3

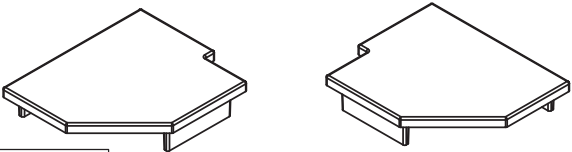
 PPL1076

(L) X1

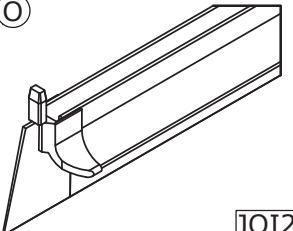
 1 = 1
 VIS22

(M) X1

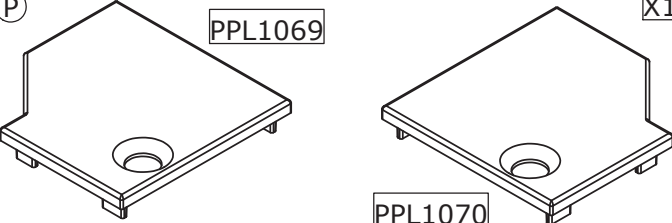
 JOI282-01

(N) X1

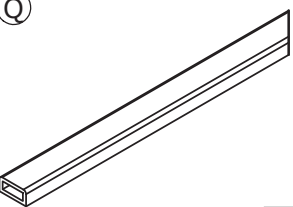
 PPL1071
 PPL1072

(O) X1

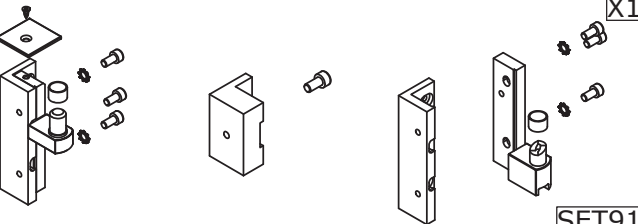
 JOI285

(P) X1

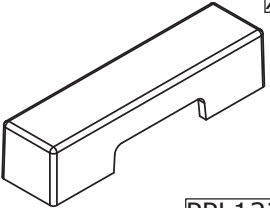
 PPL1069
 PPL1070

(Q) X1

 5918

(R) X1

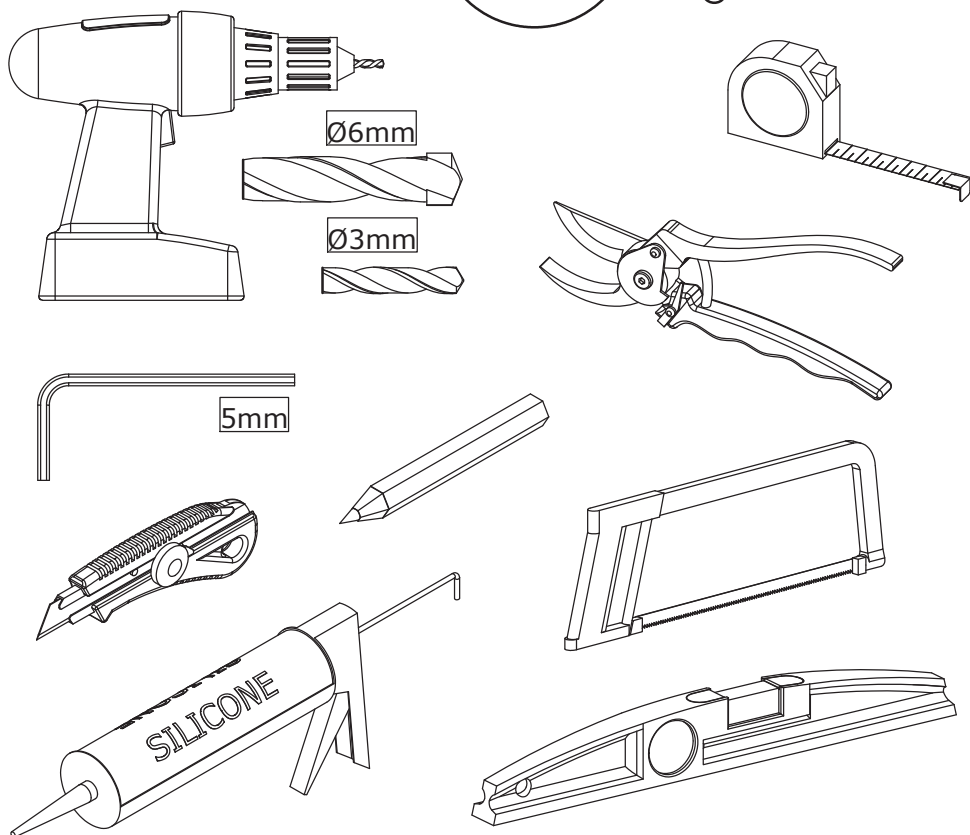
 SET91

(S) X2

 PPL1226

Matériel nécessaire
 Tools required
 Herramientas necesarias
 Materiale necessario
 Benodigd gereedschap
 Werkzeuge Erforderlich



Utiliser un silicone adapté au matériau de chaque support (faïence, acrylique, etc.)
 Use a silicone sealant that is intended for the surrounding materials (ceramic, acrylic, etc.)
 Usar una silicona adecuada para cada tipo de material (loza, acrílico, etc.)
 Utilizzare un silicone adatto a qualsiasi materiale (ceramica, acrilico, ecc.)
 Gebruik siliconenkit die geschikt is voor iedere ondergrond (tegelwerk, acryl, etc.)
 Für das jeweilige Trägermaterial (Stein, Acryl usw.) geeignetes Silikon verwenden.



REVERSIBILITE/REVERSIBILITY/REVERSIBILITA/REVERSIBILITA
MONTAGE OMKEREN/OMKEERBAARHEID/

MONTAGE A GAUCHE
LEFT HAND
MONTAGGIO A SINISTRA
MONTAJE A LA IZQUIERDA
MONTAGE LINKS
LINKSSEITIGE MONTAGE

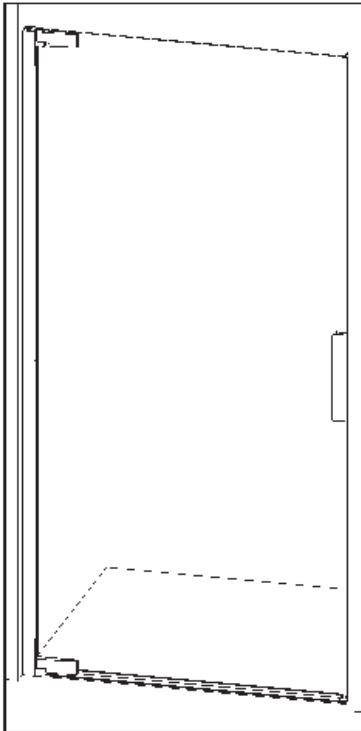

MONTAGE A DROITE
RIGHT HAND
MONTAGGIO A DESTRA
MONTAJE A LA DERECHA
MONTAGE RECHTS
RECHTSSEITIGE MONTAGE

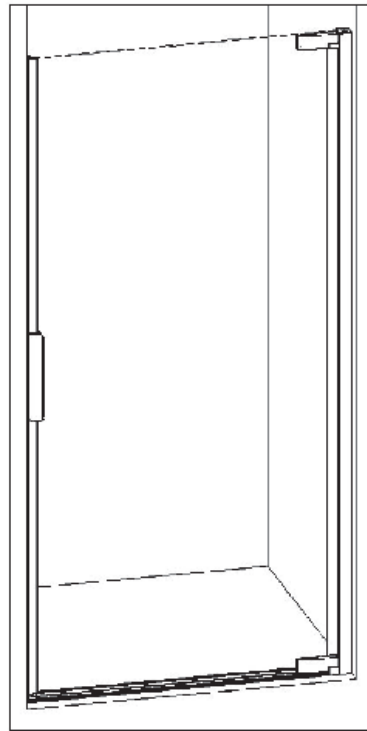

Vous avez la possibilité de réaliser un montage à droite ou un montage à gauche. Notre notice d'installation décrit un montage à gauche. si vous voulez réaliser un montage à droite, il vous suffit d'inverser le montage.

This cubicle can be installed either left or right hand. These installation instructions show a left hand installation.

Avete la possibilità di effettuare il montaggio a destra o a sinistra. Il nostro manuale descrive il montaggio a sinistra. Se volete realizzare il montaggio a destra è sufficiente invertire varie fasi di montaggio.

Puede realizar un montaje a la derecha o un montaje a la izquierda. Nuestro folleto de instalación describe un montaje a la izquierda. Si desea montar su cabina a la derecha sólo tendrá que realizar el montaje al contrario.

U kunt de cabine rechts of links monteren. Onze handleiding beschrijft de linkse montage van de cabine. Keer de montage om als u de cabine rechts wilt monteren.

Sie können eine rechtsseitige Montage oder eine Linksseitige Montage vornehmen. In unserer Montageanleitung wird eine linksseitige Montage beschrieben. Wenn Sie eine rechtsseitige montage vornehmen möchten, brauchen Sie lediglich die Montage umzukehren.

01

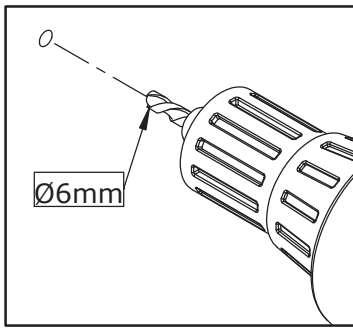

2

1

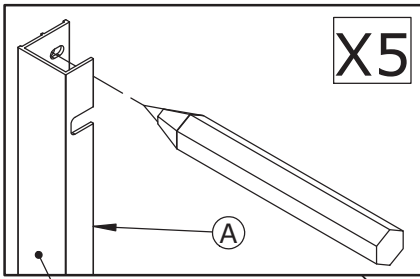

Côté extérieur
Outside
Exterior
Esterno
Buitenkant
Außen

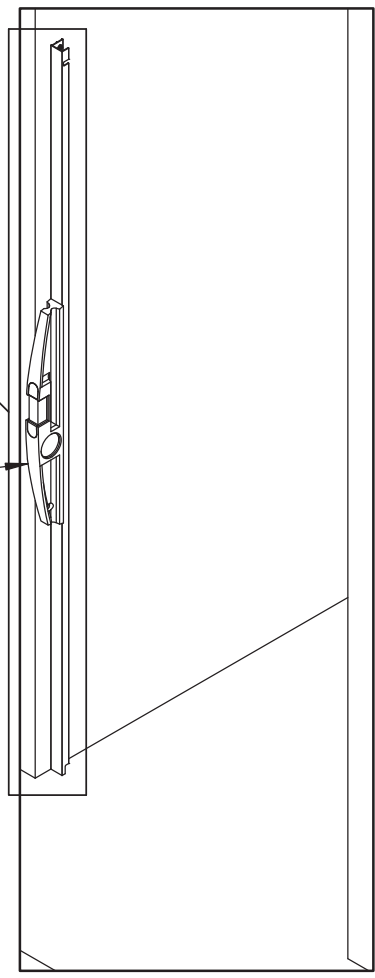
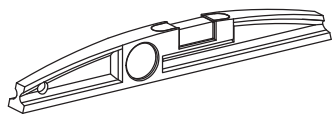

Receveur
Shower tray
Plato de ducha
Piatto doccia
Douchebak
Duschwanne

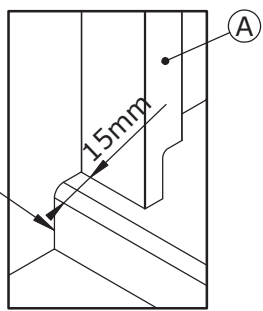

02

VUE INTERIEURE
INTERIOR VIEW
VISTA INTERIOR
BINNENZICHT
INNENANSICHT

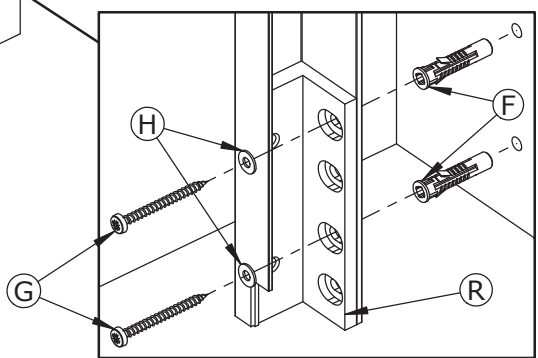
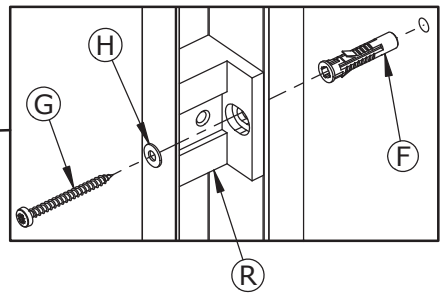
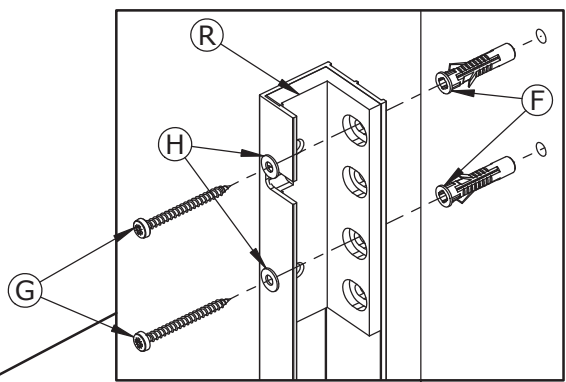
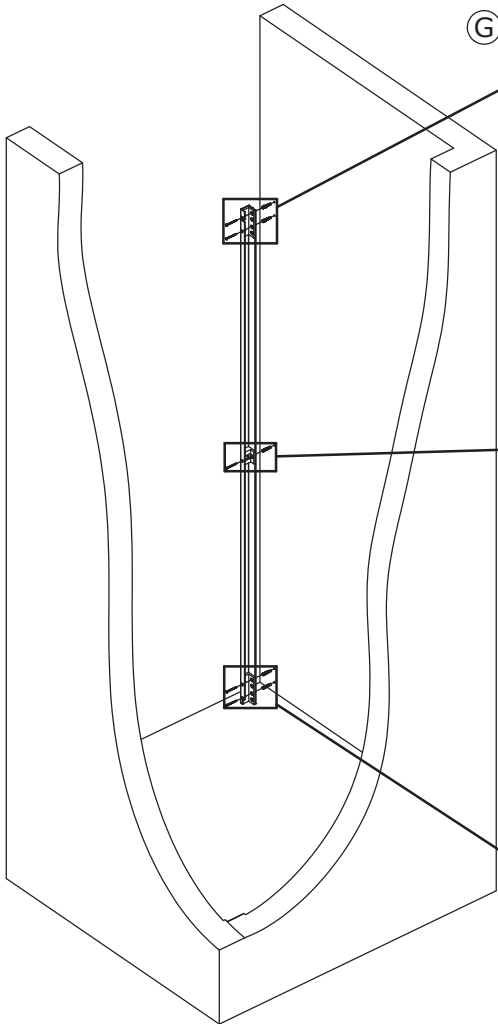

03

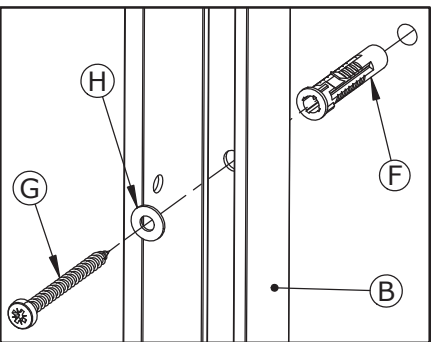

3

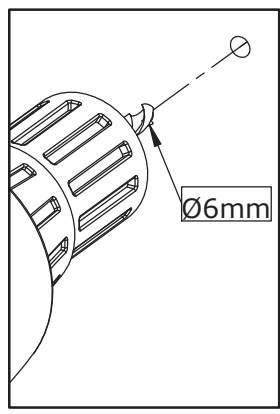

2

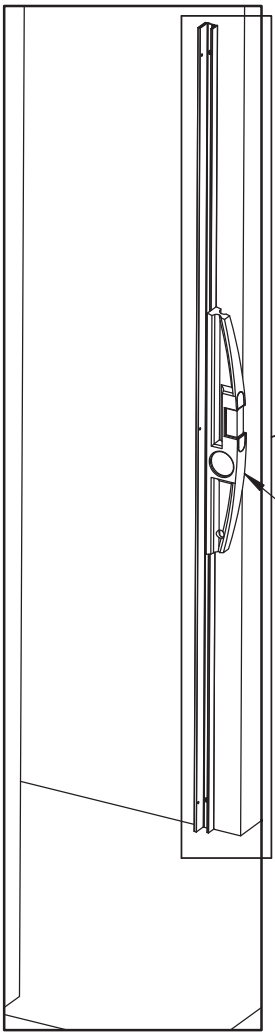

1

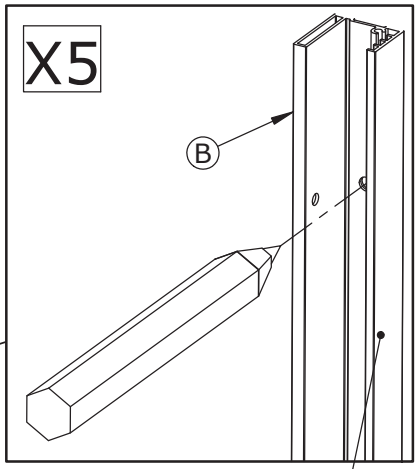

Côté extérieur
 Outside
 Exterior
 Esterno
 Buitenkant
 Außen

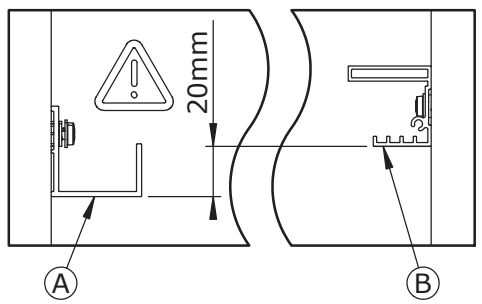
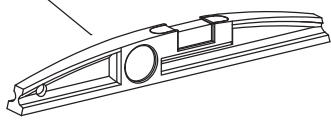

A

B

04

VUE INTERIEURE
INTERIOR VIEW
VISTA INTERIOR
VISTA INTERNA
BINNENZICHT
INNENANSICHT

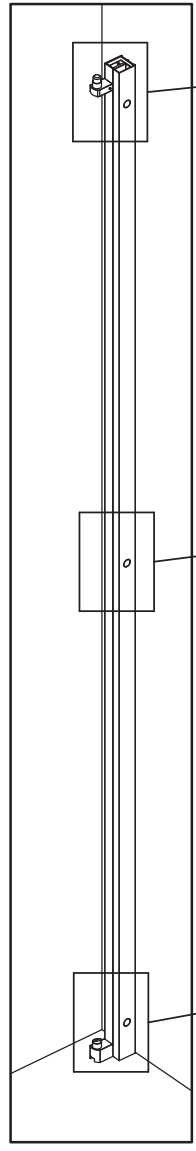
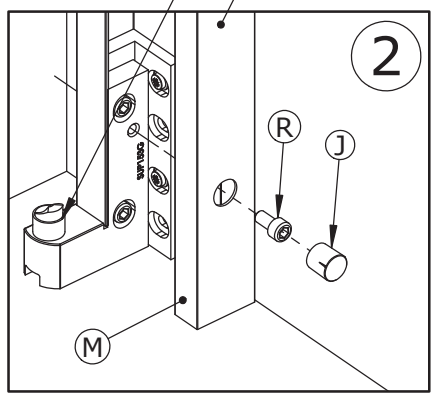
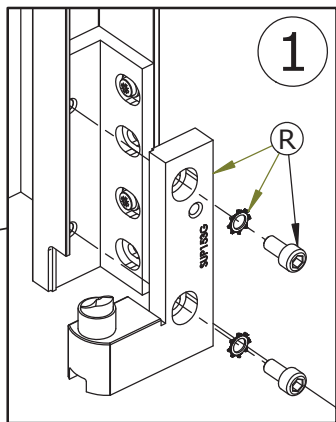
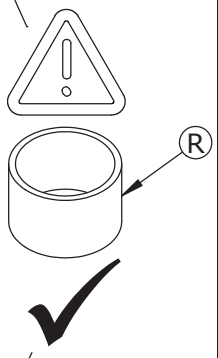
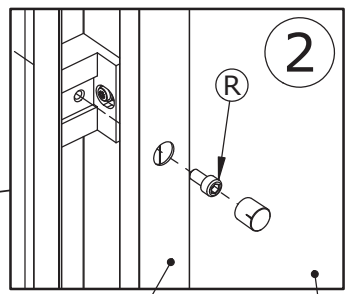
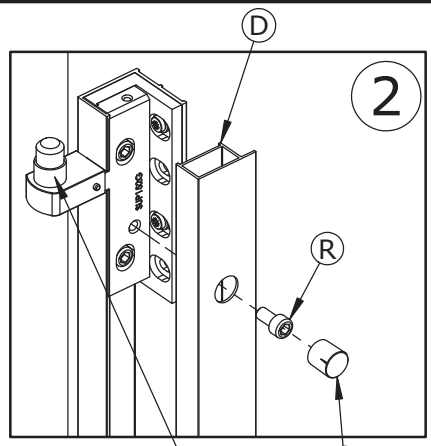
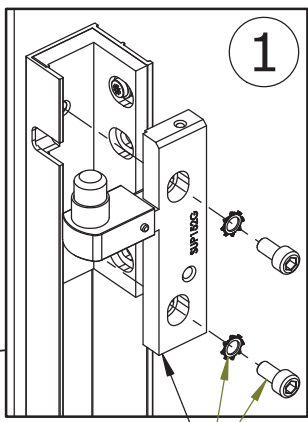

05

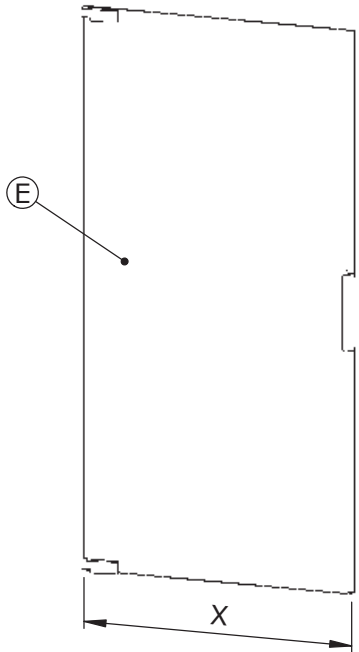

EXTERIEUR
OUTSIDE
EXTERIOR
ESTERNO
BUITENKANT
AUßEN

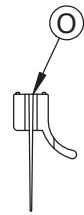

INTERIEUR
INSIDE
INTERIOR
INTERNO
BINNENKANT
INNEN

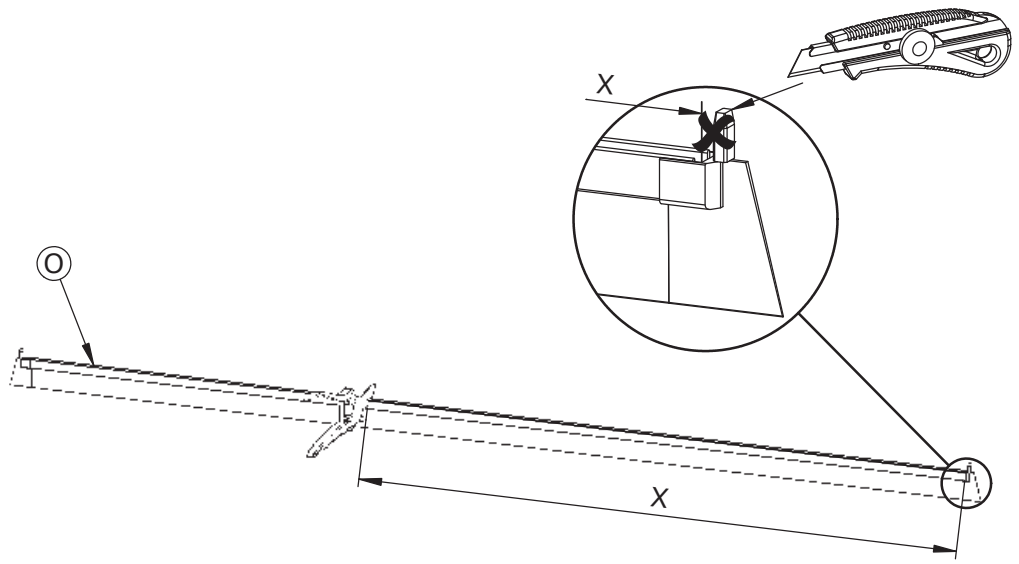

06

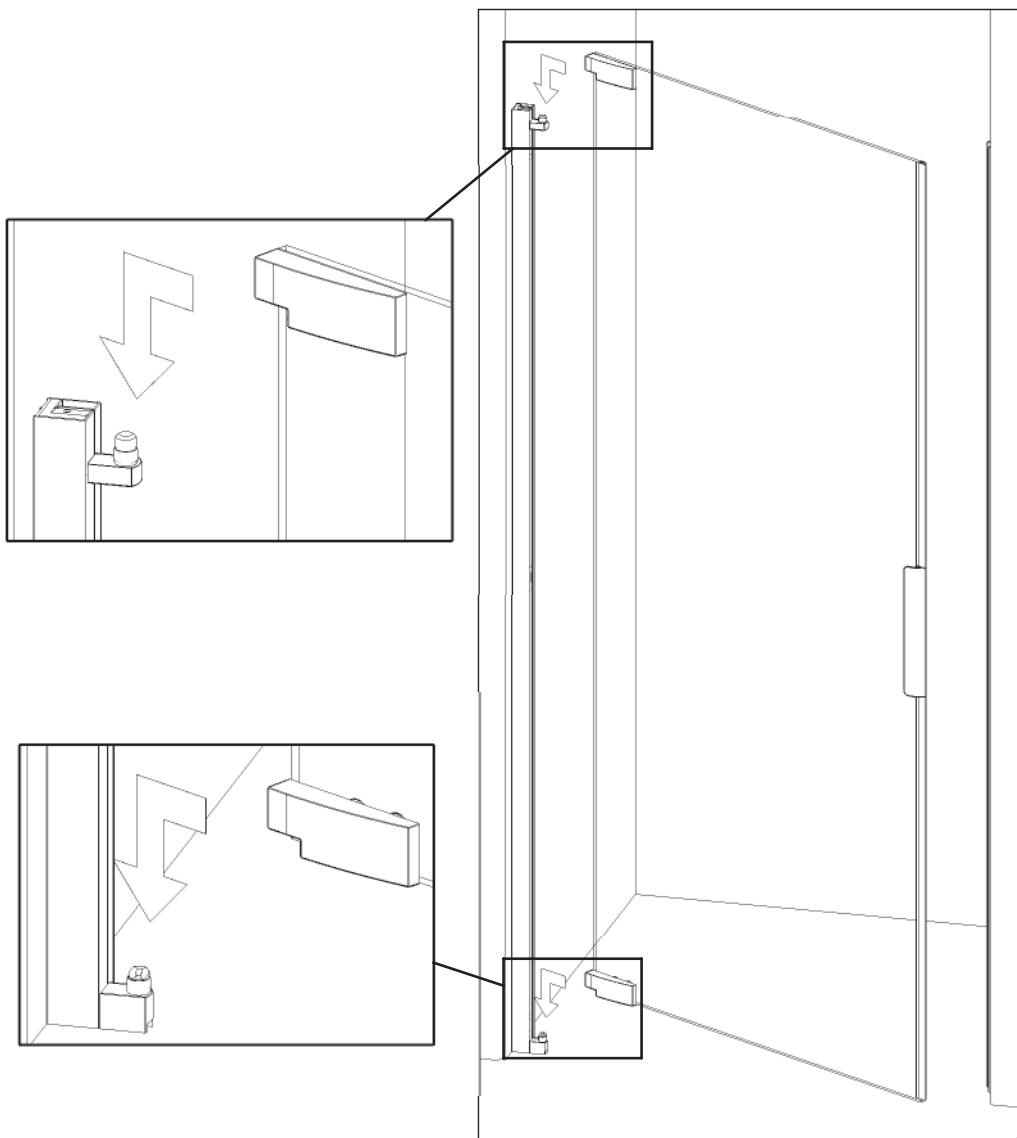

07

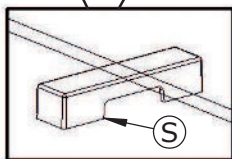
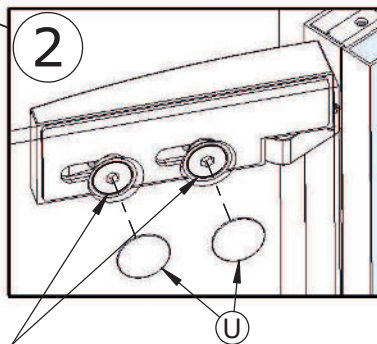
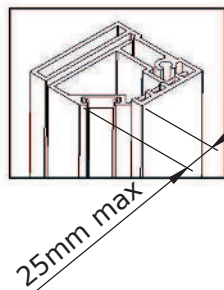
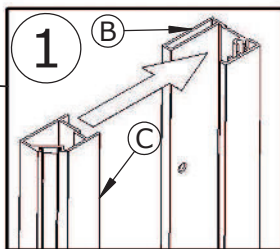
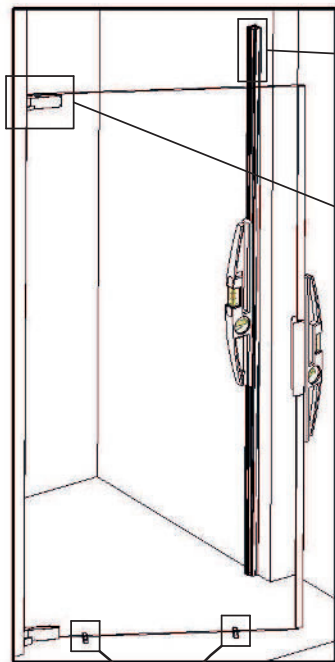

Si nécessaire, desserrer, régler l'aplomb et l'aimantation, puis resserrer (Couple de serrage : 9N.m).

If necessary, loosen the screws, check the level, line up the magnetic strips and re-tighten (Tightening torque : 9N.m).

Se necessario svitare, regolare a piombo e poi serrare (Coppia di serraggio : 9N.m).

Si fuese necesario, aflojar, nivelar la puerta y el imán y luego volver a apretar (Par de apriete : 9N.m).

Indien nodig, losschroeven, magneetstrips afstellen en opnieuw vastschroeven (Aandraaimoment : 9N.m).

Sofern erforderlich, Schrauben lösen, Senkrechte und Magnetisierung einstellen, wieder festschrauben (Anzugsdrehmoment : 9N.m).

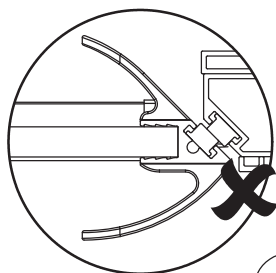

3

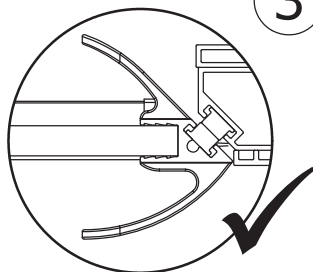

X3

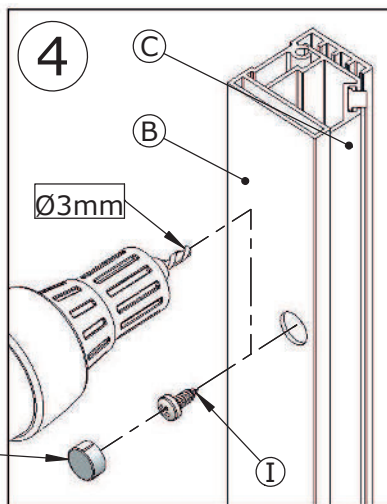

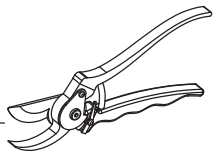
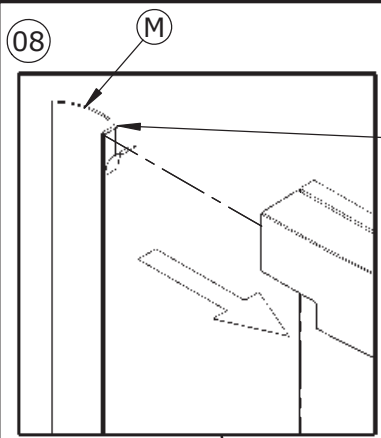

EXTERIEUR
OUTSIDE
EXTERIOR
ESTERNO
BUITENKANT
AUßEN

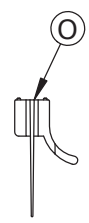

INTERIEUR
INSIDE
INTERIOR
INTERNO
BINNENKANT
INNEN

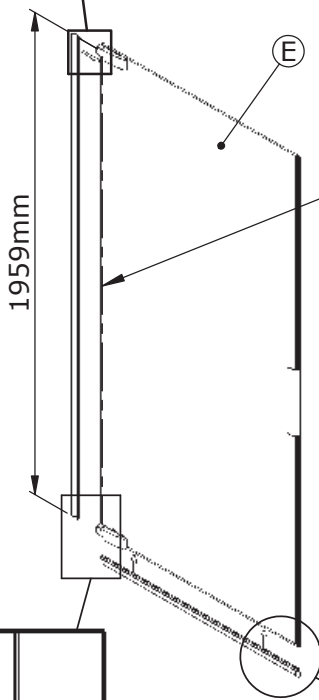

Avant de coller le joint (M), la surface doit être nettoyée, dégraissée et sans poussière, avec un nettoyeur à base d'alcool.
 Before to put the seal (M), the surface must be cleaned, degreased and without dust with alcohol based cleaner.
 Prima di incollare la guarnizioni (M), la superficie deve essere pulita, sgrassata e senza polvere, con un detergente a base di alcool.
 Antes de poner la junta (M), la superficie debe limpiarse, desengrasa y sin polvo, con un limpiador a base de alcohol.
 Vóór het lijmen van de afdichting (M), moet het oppervlak worden gereinigd, ontvet en stofvrij, met een basis van alcohol reinigingsmiddel.
 Bevor das Fugen zu kleben (M), soll die Oberfläche zu reinigen, entfetten und staubfrei, mit einem alkoholhaltigen Reinigungsmittel.

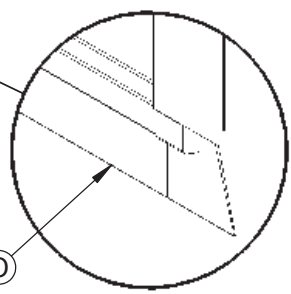
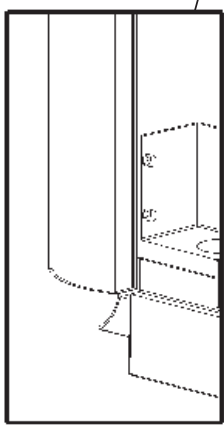

09

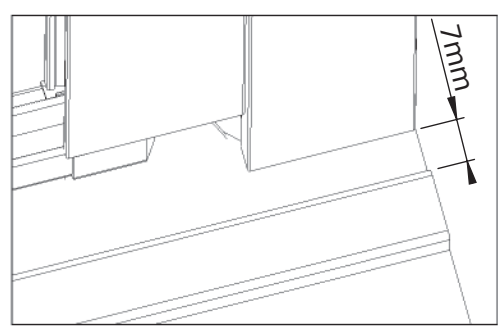
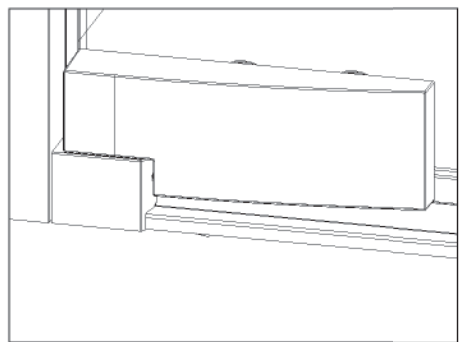
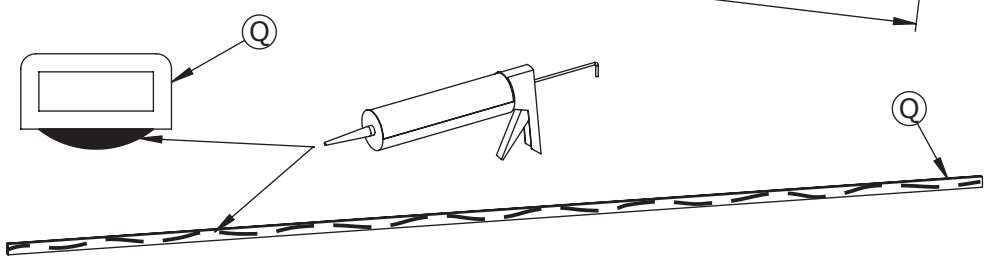
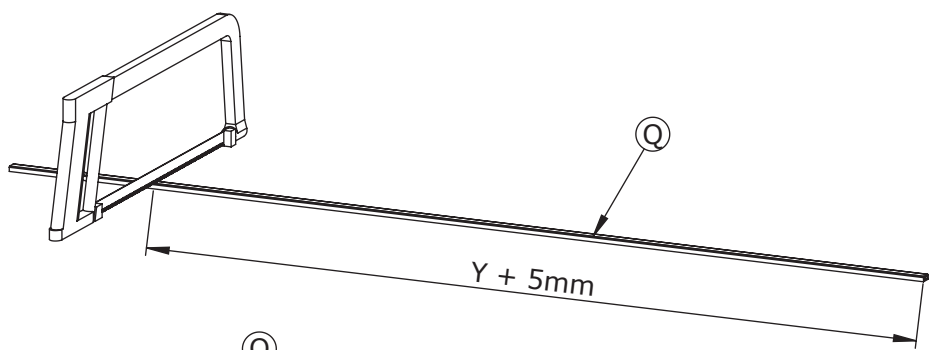
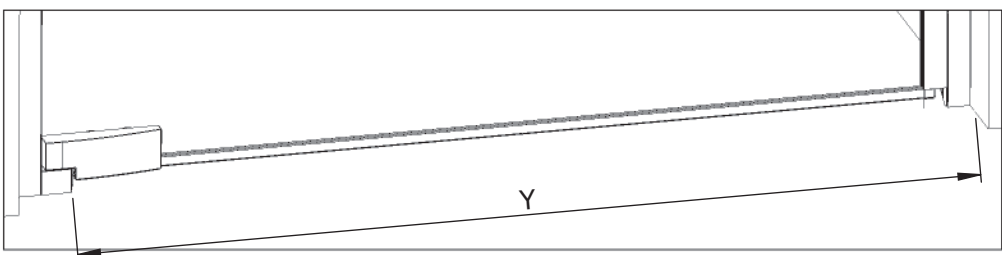

10

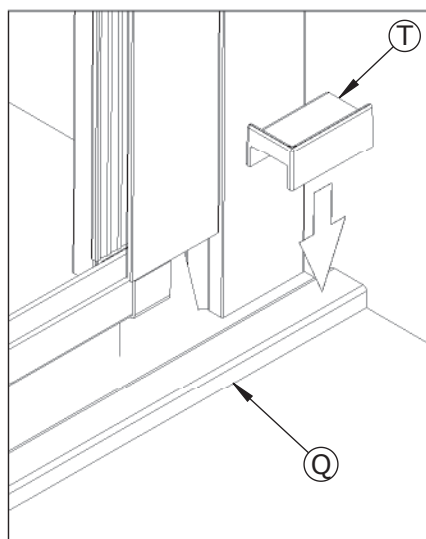
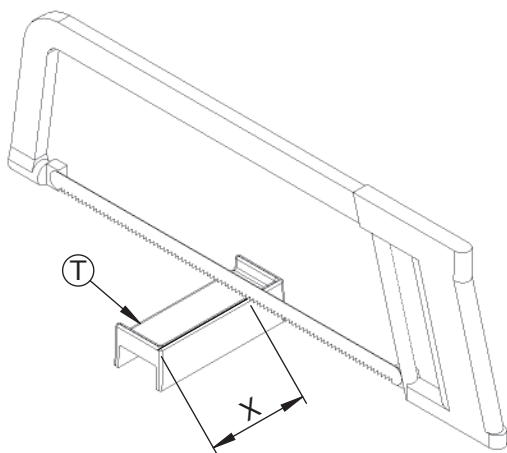
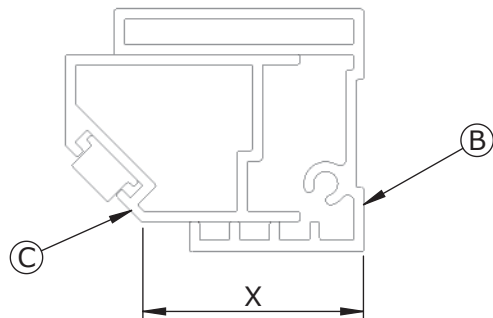

11

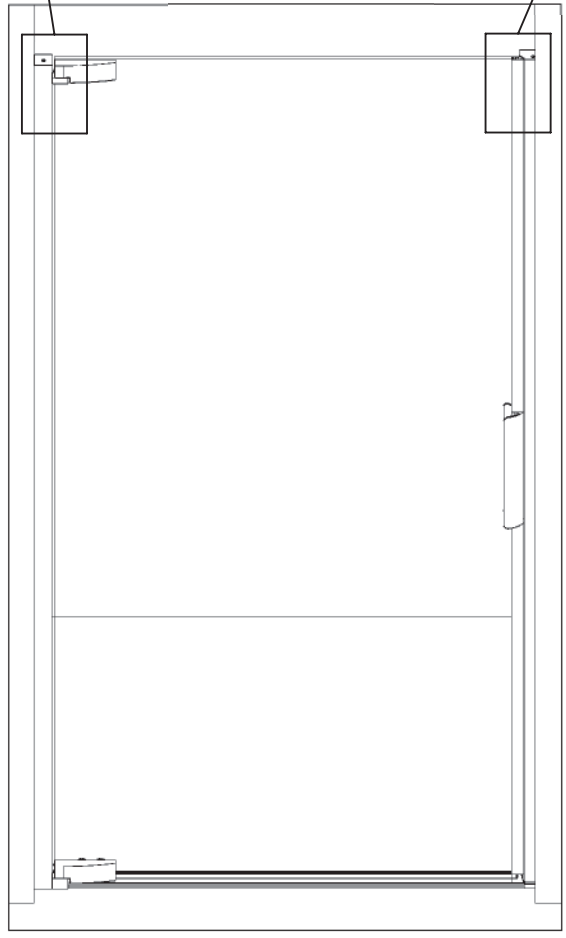
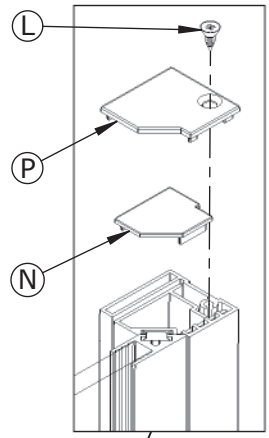
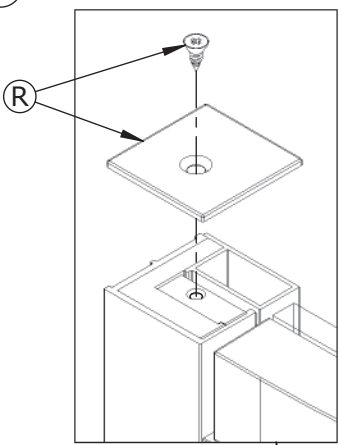

12



24H

Laisser la porte ouverte le temps du séchage.
 Leave the door open while the silicon is drying.
 Lasciare la porta aperta per il tempo di asciugatura.
 Dejar la puerta abierta mientras se seque.
 Laat de deur open terwijl de silicone droogt .
 Lassen Sie die Tür geöffnet, bis das Silikon getrocknet ist.

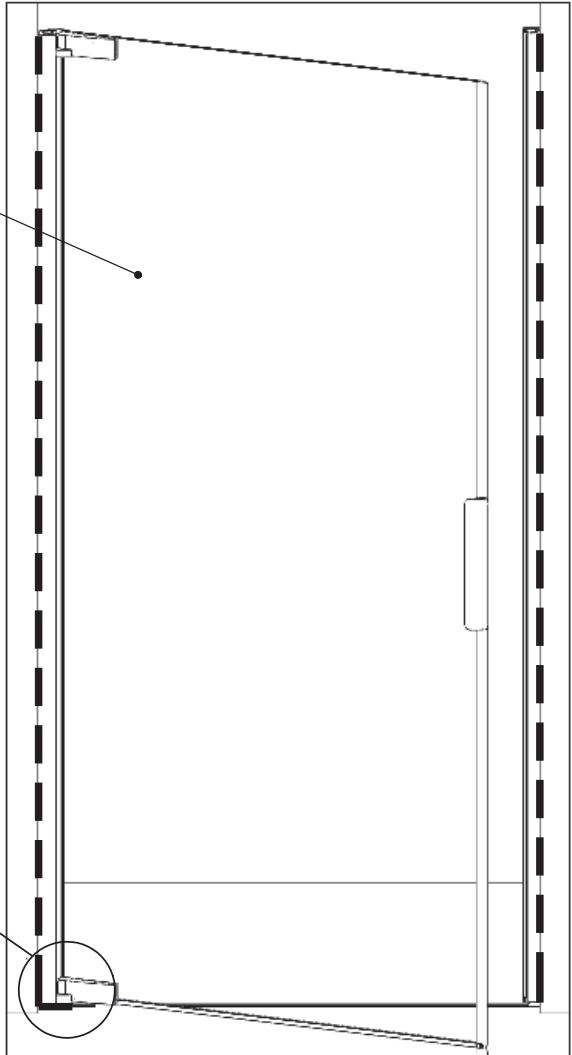



AQUAPRODUCTION, Site industriel, F - 44680 Chéméré

16

EN 14428

Paroi de douche, fabriquée en verre de silicate
sodo-calcique de sécurité trempé thermiquement

Aptitude au nettoyage : réussite

Résistance à l'impact/propriétés de fragmentation : réussite

Durée : réussite



SAV
SERVICE HELPLINES
ASSISTENZA POST-VENDITA
SERVICIO POSTVENTA

FRANCE

02 40 21 29 45

SCHWEIZ

(01) 748 17 44

UK

020 8842 0033

ESPANA

93 544 60 76

IRELAND

04697 33102

NEDERLAND

0475 487 100

DEUTSCHLAND

+49 (0) 6074 / 30928 0

BELGIE

+31 475 487 100

ITALIA

(0382) 6181

BELGIQUE

+31 475 487 100

OSTEREICH

+43 1 710 60 70

РОССИЯ

963 19 40, 773 67 22