

- F Notice de montage ● GB Installation instructions
- E Manual de instalación ● I Istruzioni di montaggio
- NL Montage-instructies ● D Montageanleitung

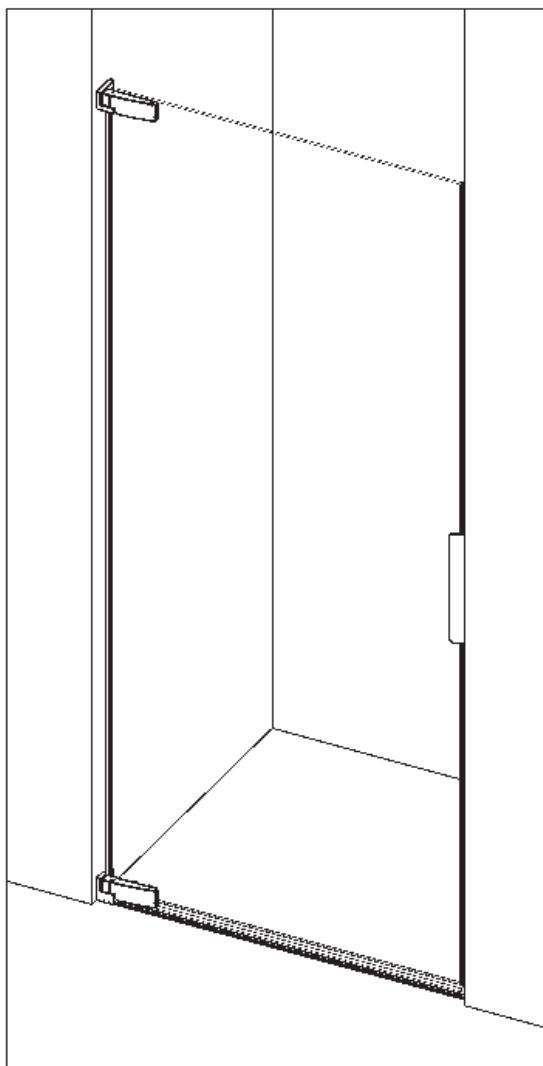

- F Attention aux étapes :
- GB Check installation steps :
- E Atención a los pasos :
- I Attenzione ai passi :
- NL Aandacht voor de stappen :
- D Achtung vor den Schritten :

P. 6 - 11 - 27

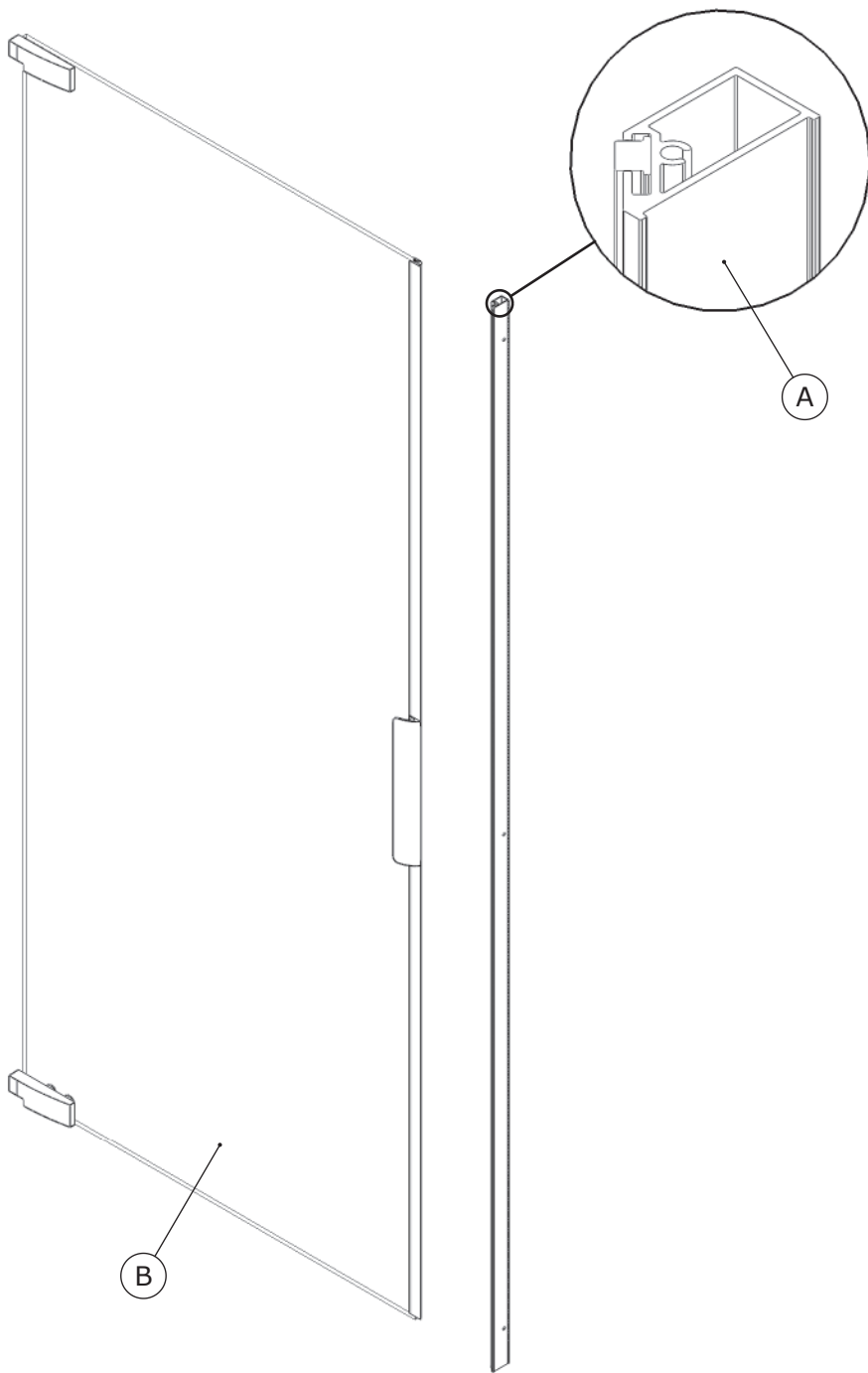

C ● Montage gauche ● Left hand x1
 ● Montaje a la izquierda
 ● Montaggio a sinistra ● Montage links
 ● Montage links

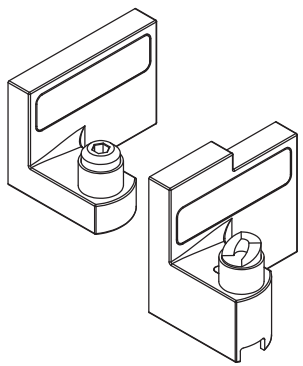

SET92G

● Montage droite ● Right hand x1
 ● Montaje a la derecha
 ● Montaggio a destra ● Montage rechts
 ● Montage rechts

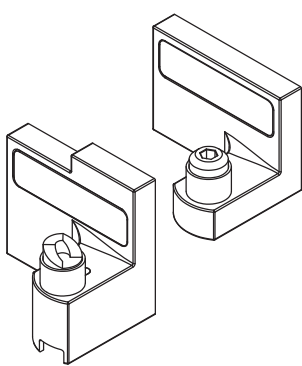

SET92D

E x7

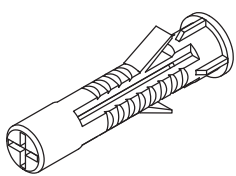

CHE02

F x7

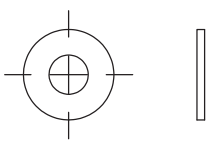

RON34

G Ø4 x7

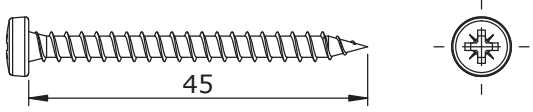

45

1=1 **VIS210**

H x1

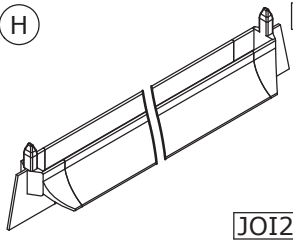

JOI285

I x1

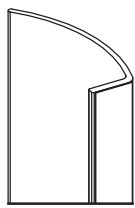

Lg=2000mm **JOI282-01**

J x1

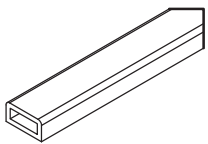

5918

K x4



PPL1052

L x2

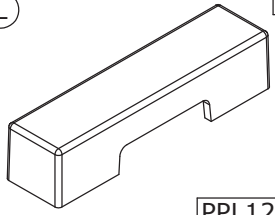

PPL1226

M Ø3.5 x1

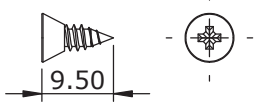

9.50

1=1 **VIS22**

N x3

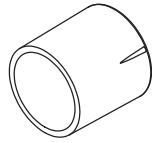

PPL1075

O ● Montage gauche ● Left hand x1
 ● Montaje a la izquierda
 ● Montaggio a sinistra ● Montage links
 ● Montage links

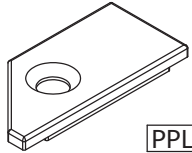

PPL1073

P ● Montage droite ● Right hand x1
 ● Montaje a la derecha
 ● Montaggio a destra ● Montage rechts
 ● Montage rechts

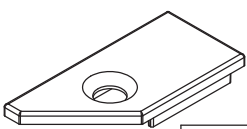

PPL1074

● Outillage nécessaire ● Tools required ● Equipamiento necesario
 ● Attrezzatura necessaria ● Benodigde gereedschap ● Werkzeuge erforderlich

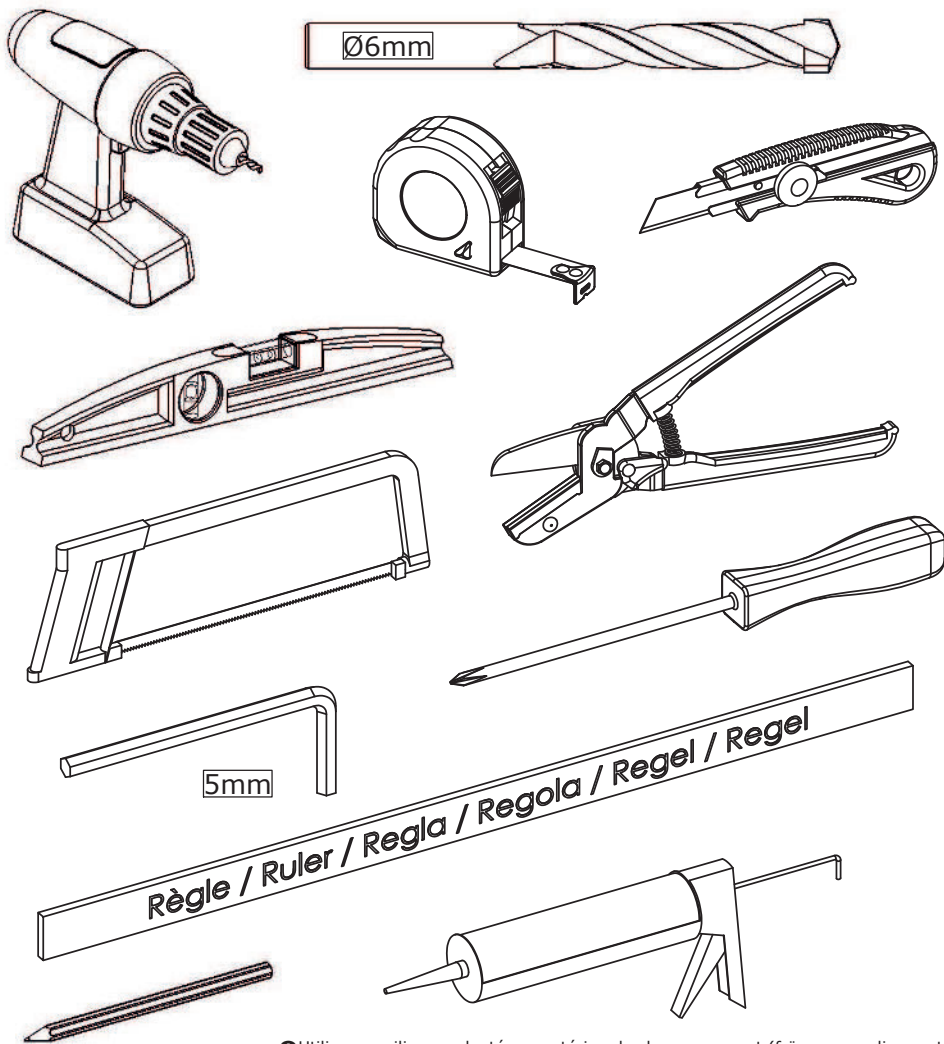

- Utiliser un silicone adapté au matériau de chaque support (faïence, acrylique, etc.)
- Use a silicone sealant that is intended for the surrounding materials (ceramic, acrylic, etc.)
- Usar una silicona adecuada para cada tipo de material (loza, acrílico, etc.)
- Utilizzare un silicone adatto a qualsiasi materiale (ceramica, acrilico, ecc.)
- Gebruik siliconenkit die geschikt is voor iedere ondergrond (tegelwerk, acryl, etc.)
- Für das jeweilige Trägermaterial (Stein, Acryl usw.) geeignetes Silikon verwenden.



F REVERSIBILITE G REVERSIBILITY E REVERSIBILIDAD
 I REVERSIBILITA N OMKEERBAARHEID D WAHLWEISE MONTAGE

F MONTAGE A GAUCHE
 G LEFT HAND
 E MONTAJE A LA IZQUIERDA
 I MONTAGGIO A SINISTRA
 N MONTAGE LINKS
 D MONTAGE LINKS

F MONTAGE A DROITE
 G RIGHT HAND
 E MONTAJE A LA DERECHA
 I MONTAGGIO A DESTRA
 N MONTAGE RECHTS
 D MONTAGE RECHTS

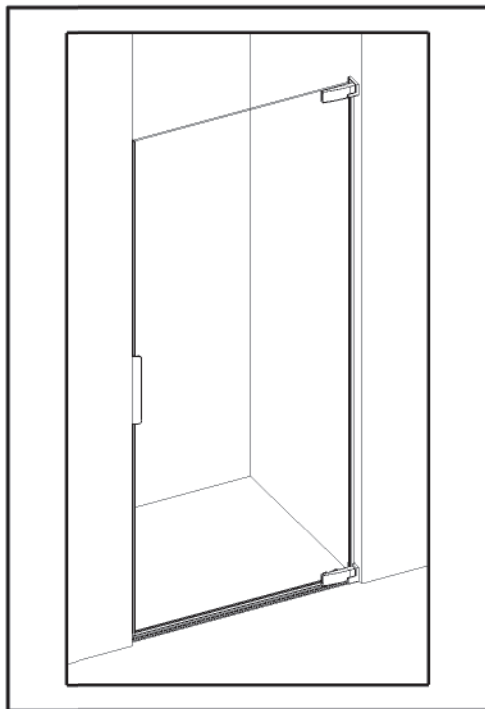
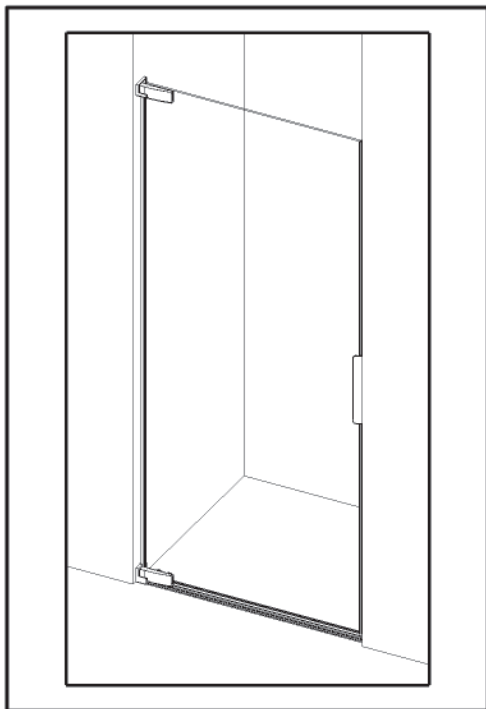

F Vous avez la possibilité de réaliser un montage à droite ou un montage à gauche. Notre notice d'installation décrit un montage à gauche. Si vous voulez réaliser un montage à droite, il vous suffit d'inverser le montage.

G This cubicle can be installed either left or right hand. These installation instructions show a left hand installation.

E Puede realizar un montaje a la derecha o un montaje a la izquierda. Nuestro folleto de instalación describe un montaje a la izquierda. Si desea montar su cabina a la derecha sólo tendrá que realizar el montaje al contrario.

I Avete la possibilità di effettuare il montaggio a destra o a sinistra. Il nostro manuale descrive il montaggio a sinistra. Se volete realizzare il montaggio a destra è sufficiente invertire varie fasi di montaggio.

N U kunt de douhecabine rechts of links monteren. Onze handleiding beschrijft de links montage van de cabine. Keer de montage om als u de cabine rechts wilt monteren.

D Sie haben die Möglichkeit, eine Montage auf der linken Seite oder eine Montage auf der rechten Seite durchzuführen. Unsere Montageanleitung beschreibt eine Montage auf der linken Seite. Wenn Sie die Montage lieber auf der rechten Seite durchführen wollen, müssen Sie nur den Montageprozess umkehren.

- Sans receveur
- Without tray
- Sin plato
- Senza piatto
- Zonder douchebak
- Ohne Duschtasse

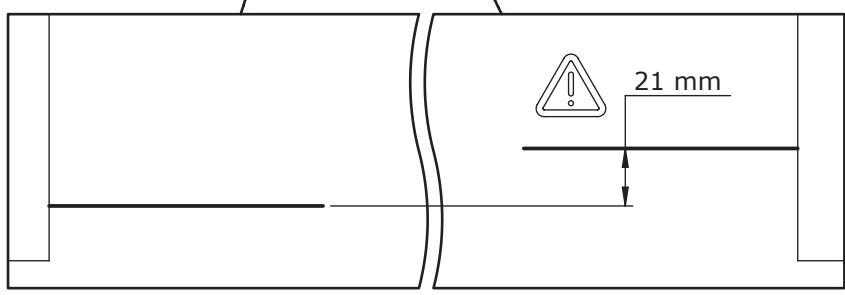

- Avec receveur
- With tray
- Con plato
- Con piatto
- Op douchebak
- Mit Duschtasse

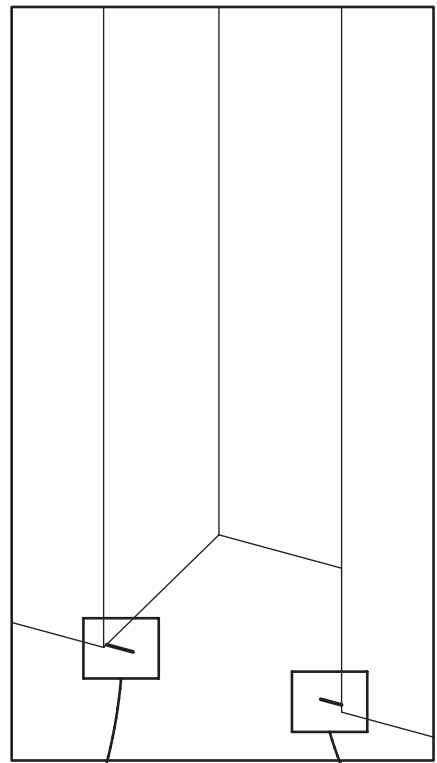
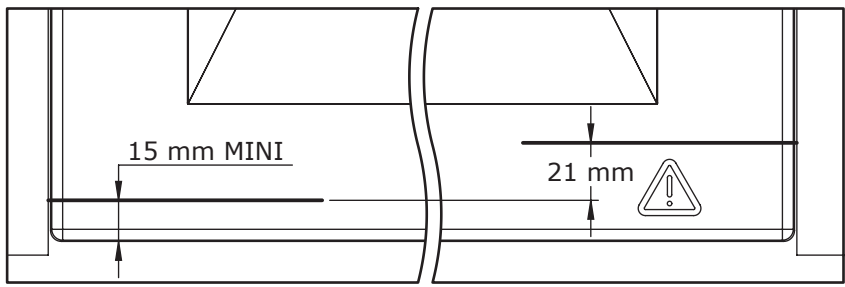

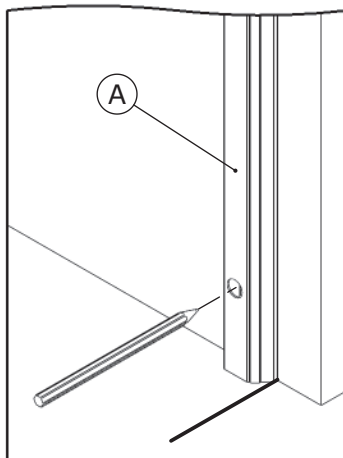
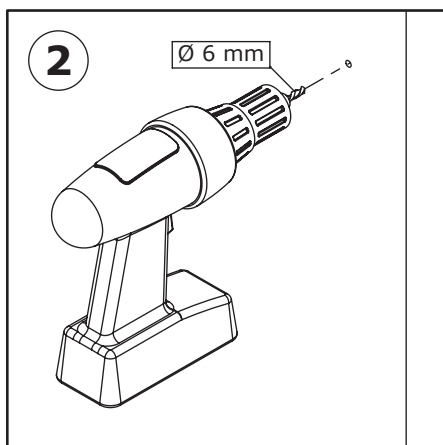
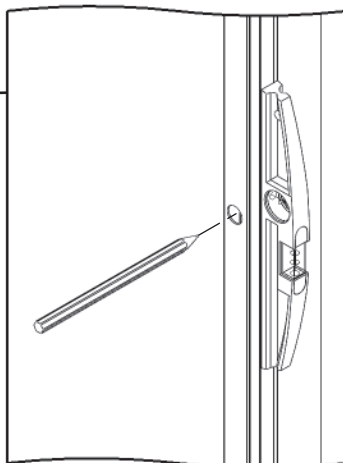
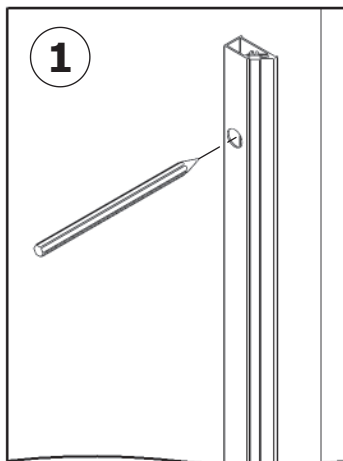
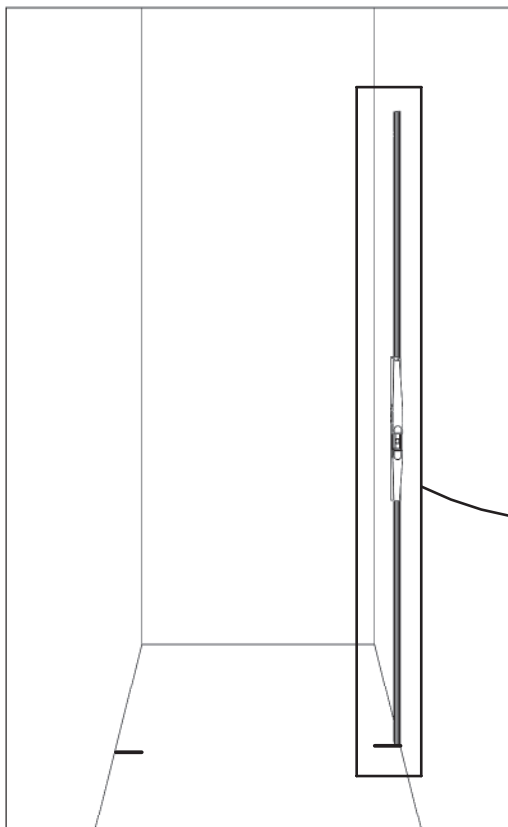

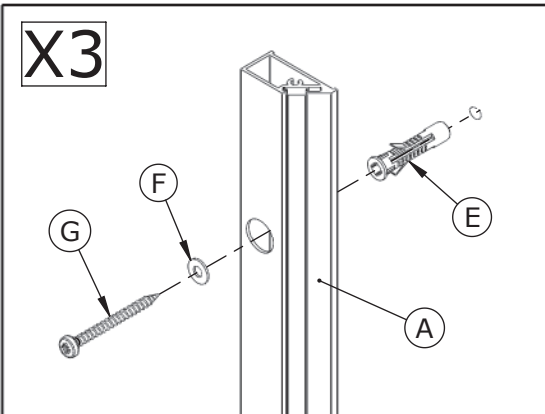
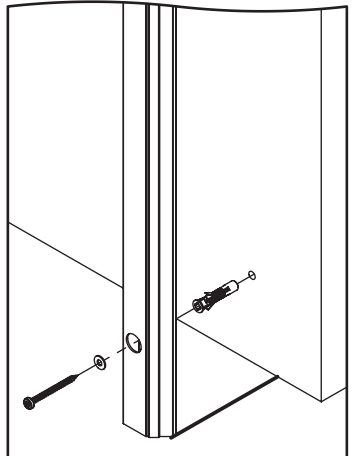
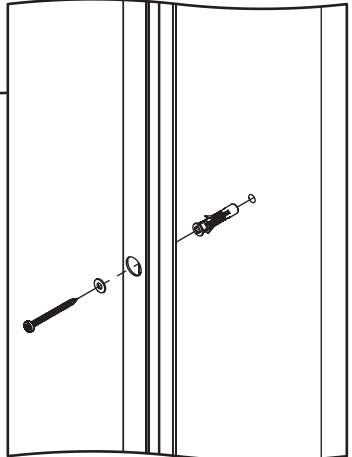
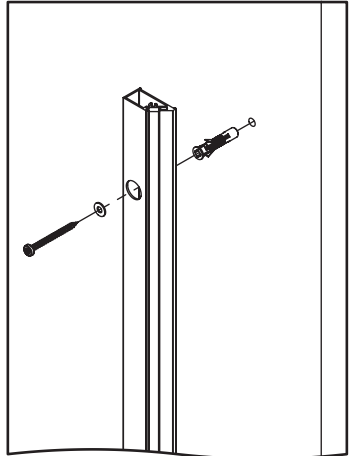
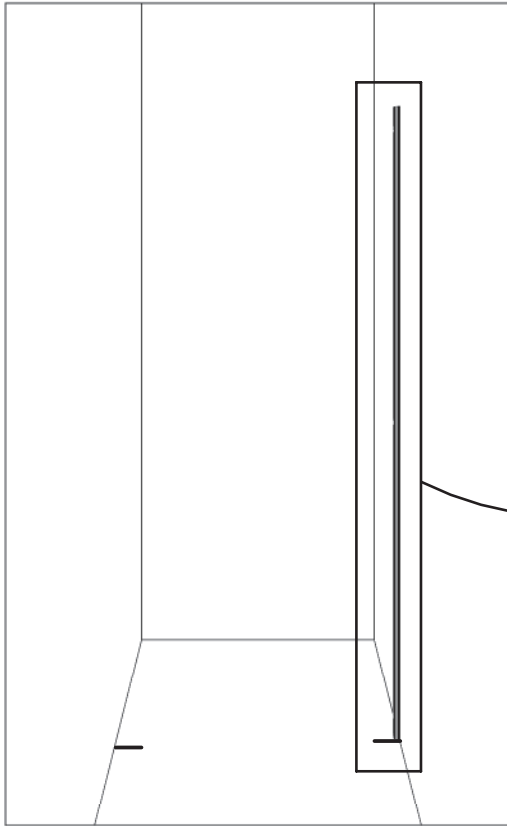

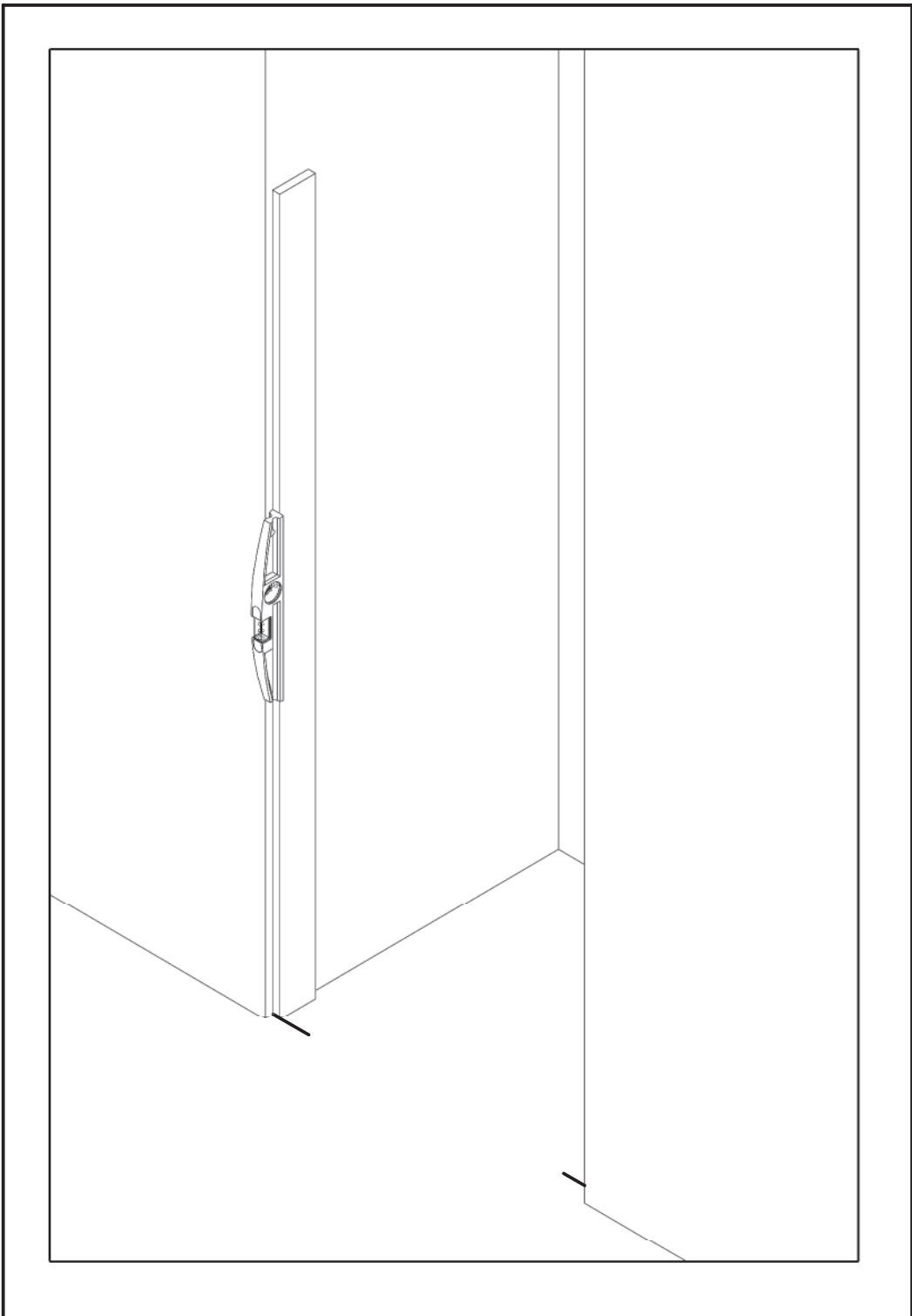

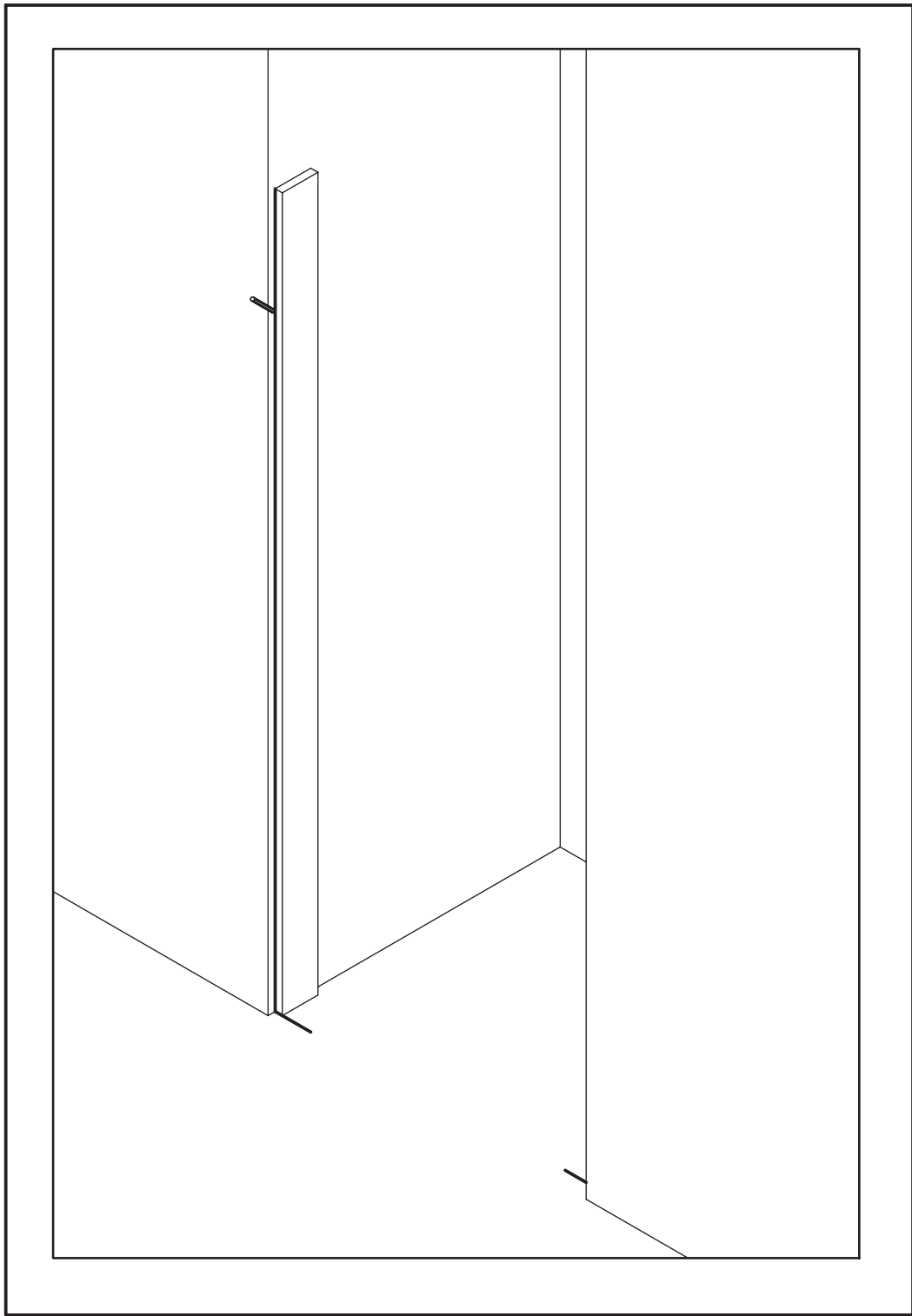

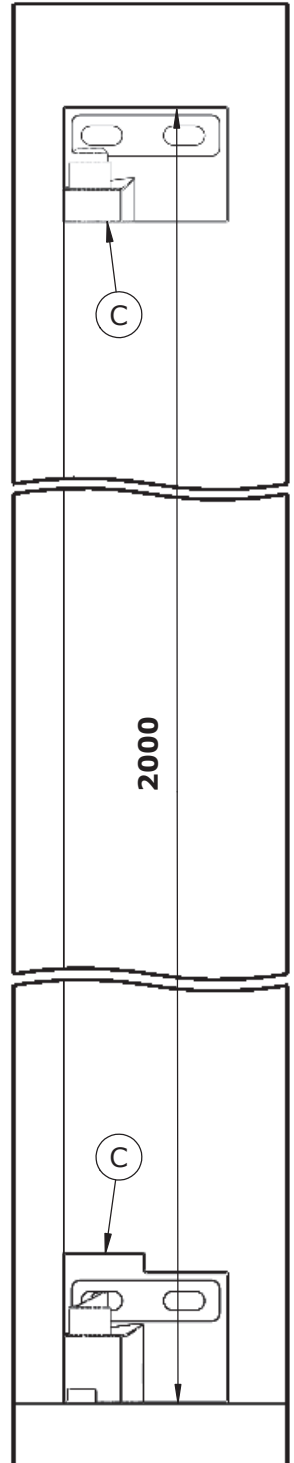
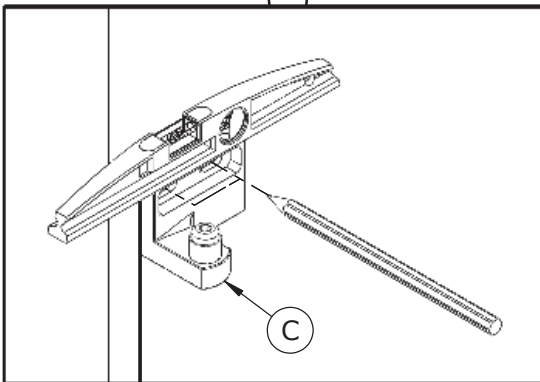
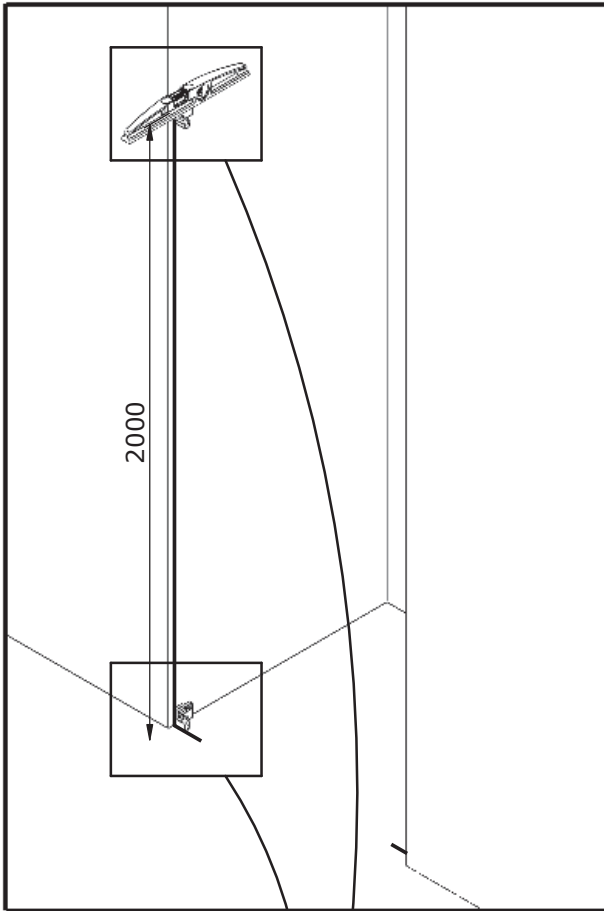

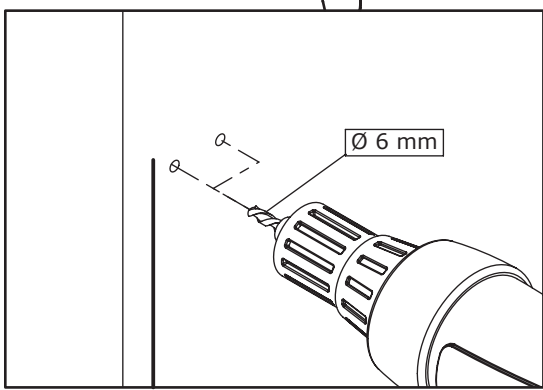
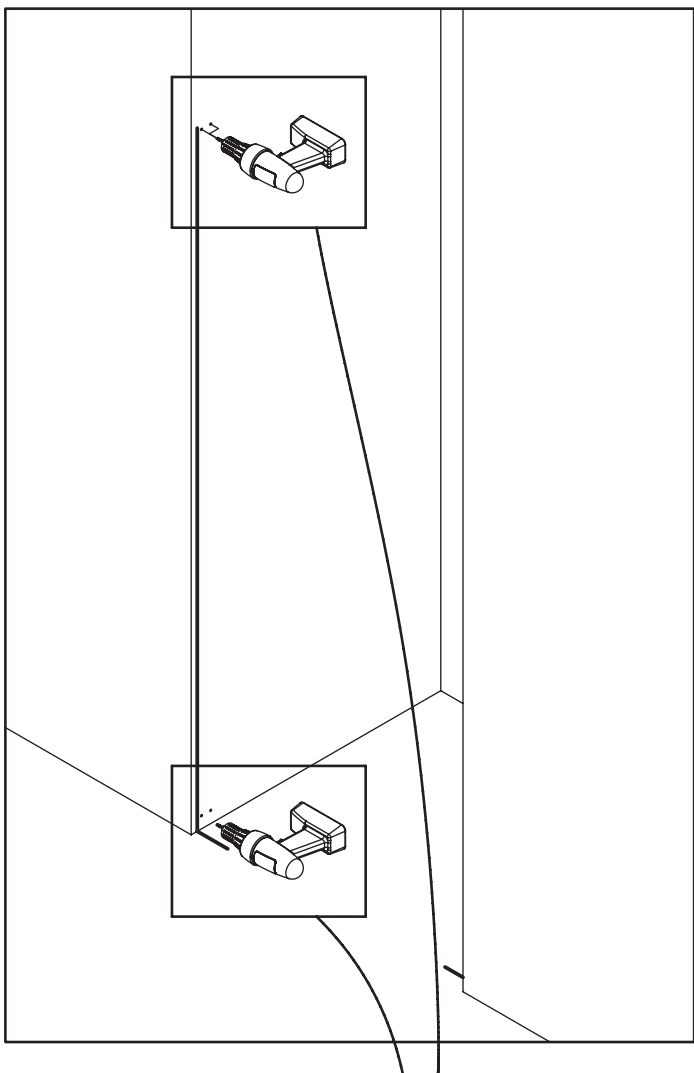

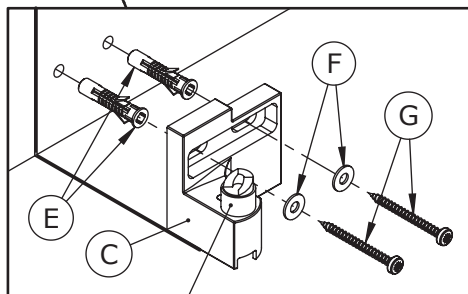
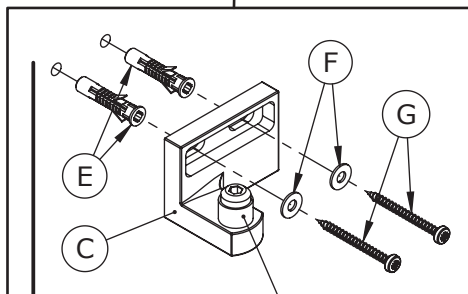
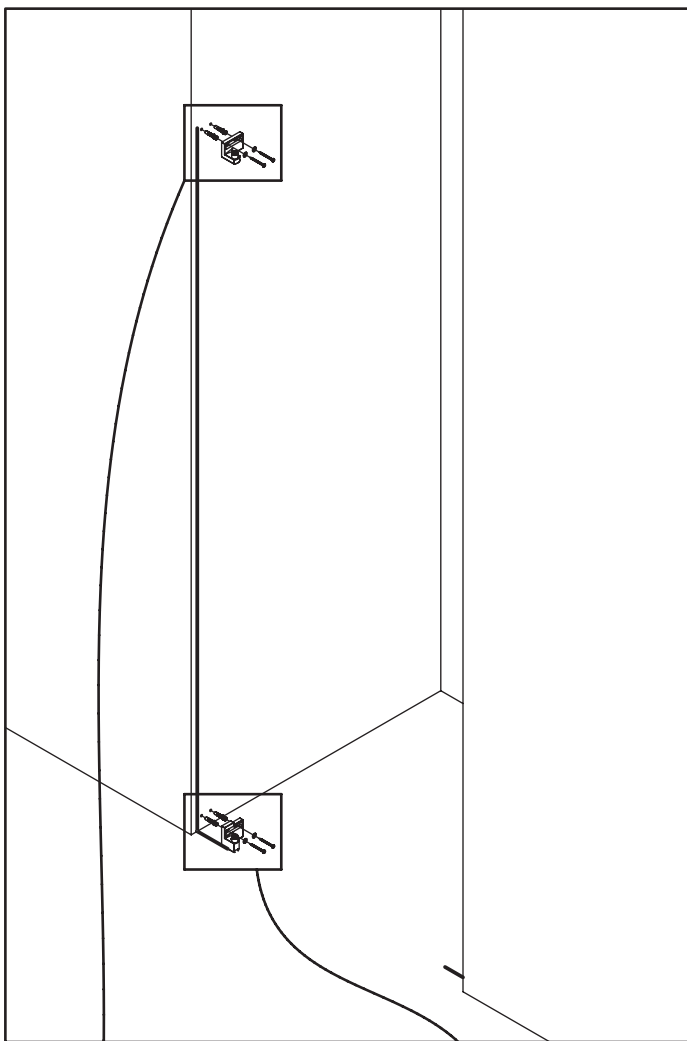

• Ne pas oublier les bagues plastiques • Do not forget the plastic rings
 • No se olvide de los anillos de plástico • Non dimenticare gli anelli di plastica
 • Vergeet niet de plastic ringen • Vergessen Sie nicht die Plastikringe

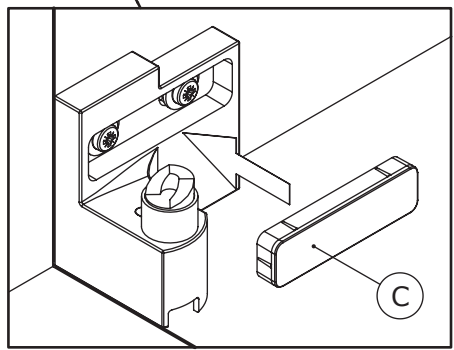
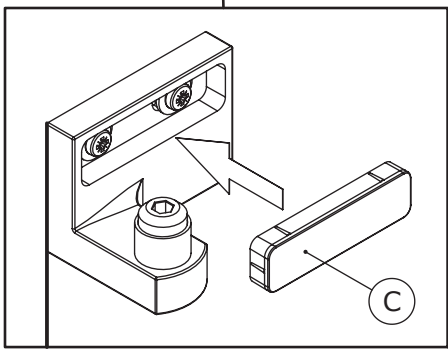
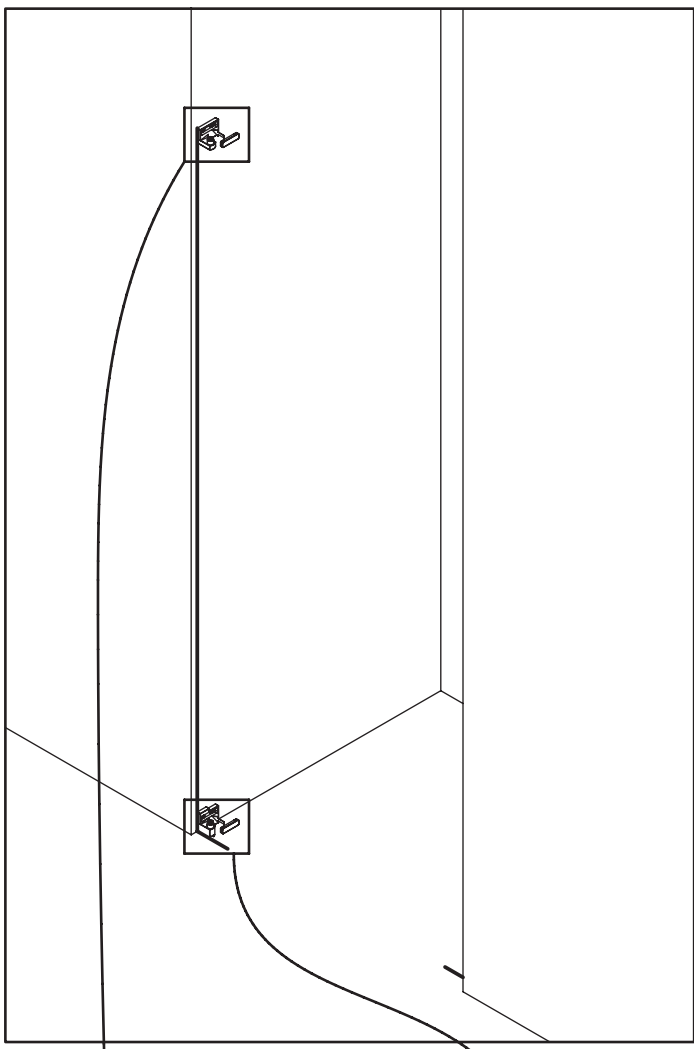

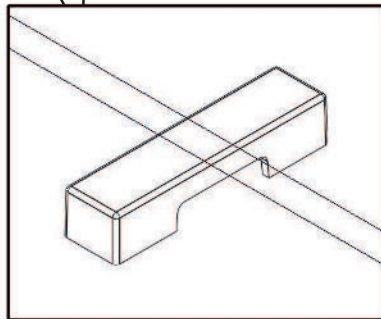
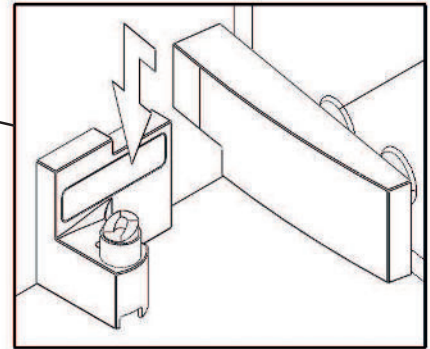
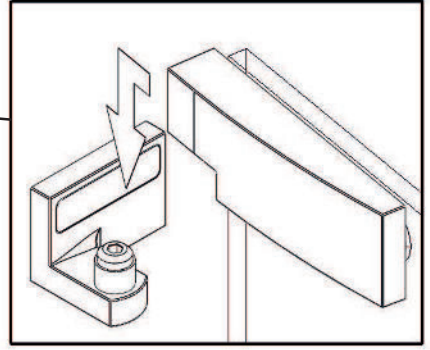
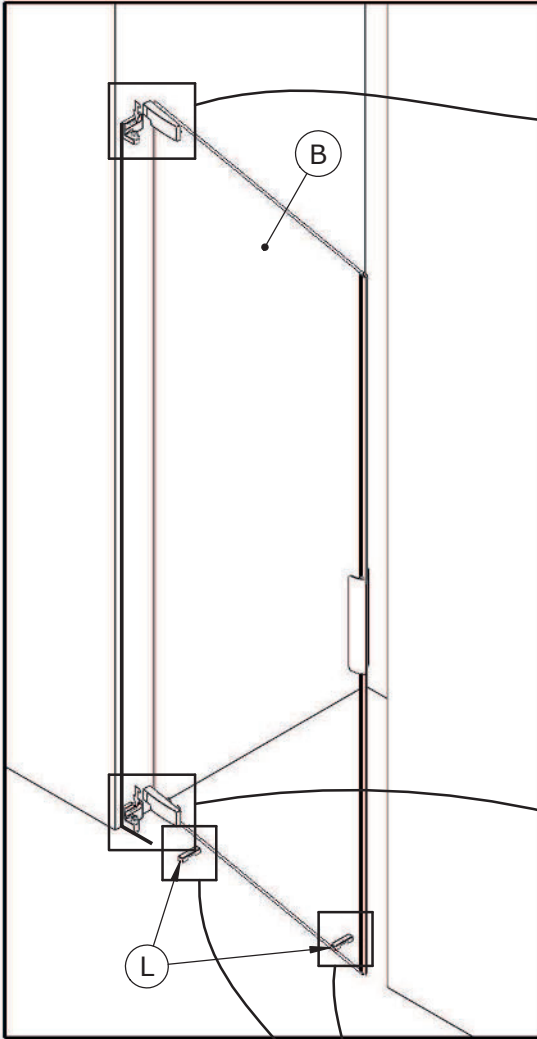

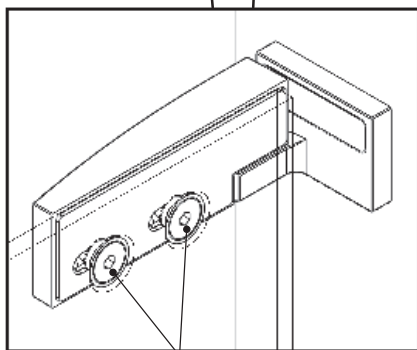
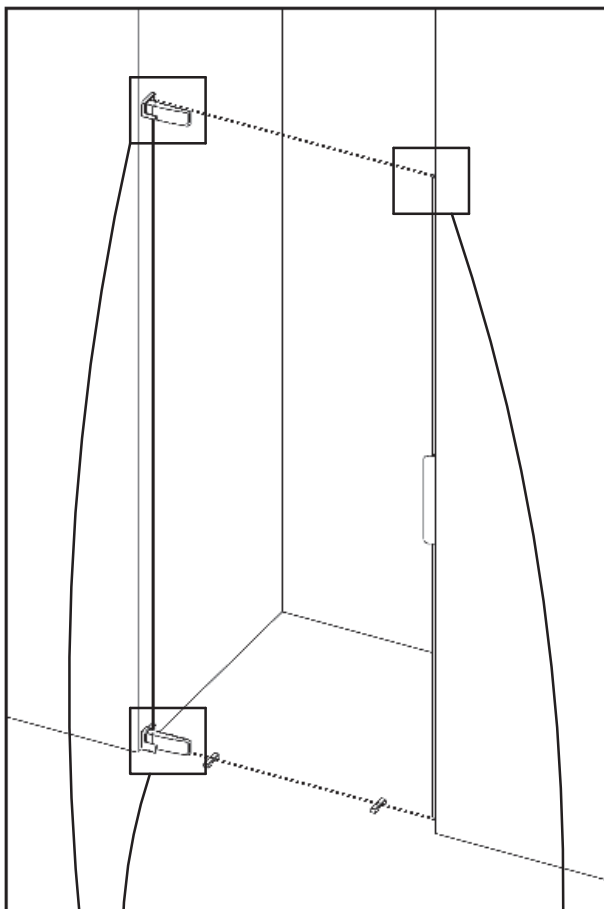

- Ⓕ Régler les portes (Couple de serrage : 9N.m)
- Ⓖ Adjust the doors (Tightening torque : 9N.m)
- Ⓔ Ajustar las puertas (Par de apriete : 9N.m)
- Ⓗ Regolare le porte (Coppia di serraggio : 9N.m)
- Ⓜ Stel de deuren (Aandraaimoment : 9N.m)
 - Ⓜ Einstellung der Senkrechten der Tür (Anzugsdrehmoment : 9N.m)

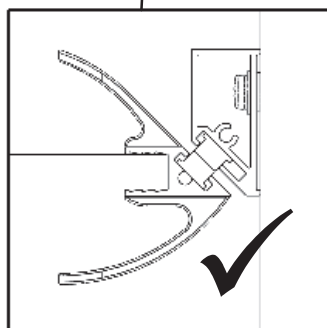

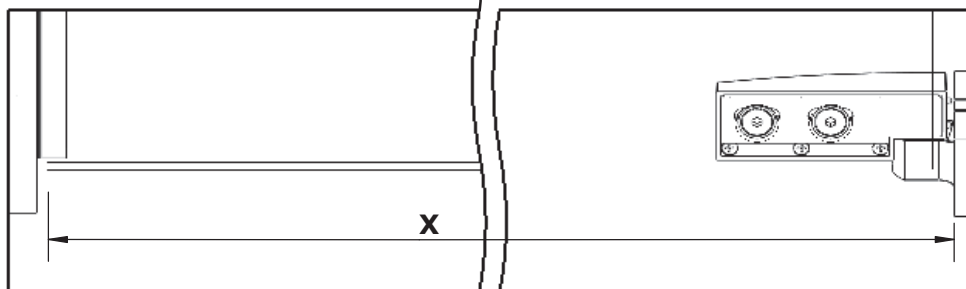
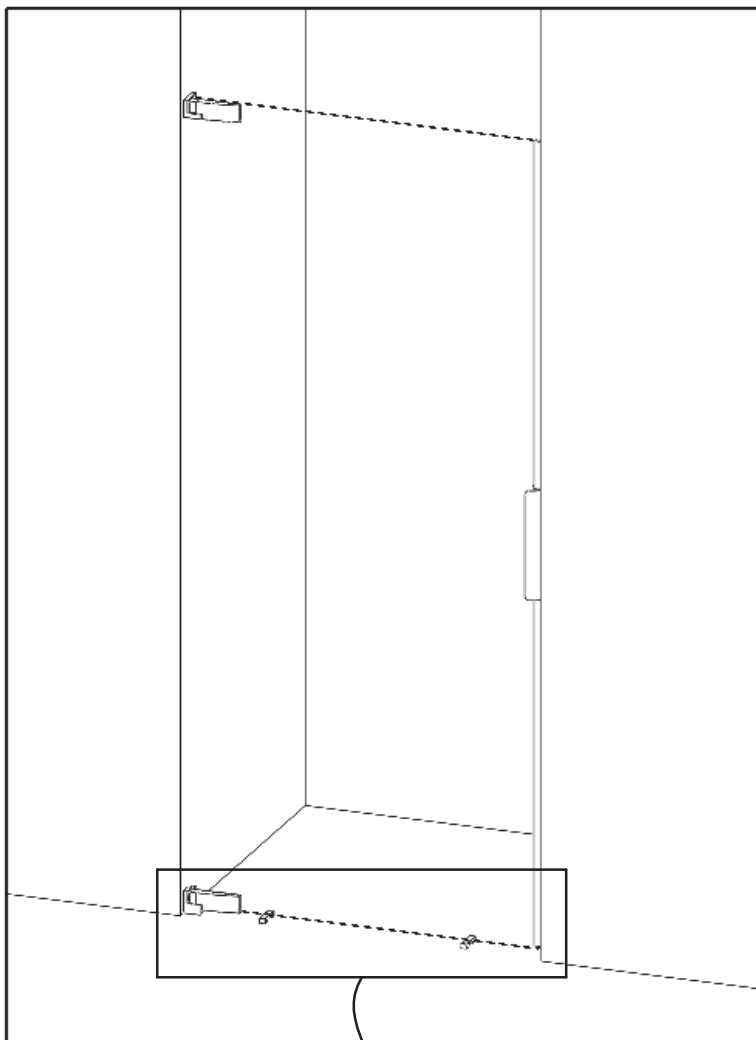

- Intérieur douche ● Inside shower ● Interior ducha
- Doccia interni ● Binnen douche ● Innenansicht der Kabine

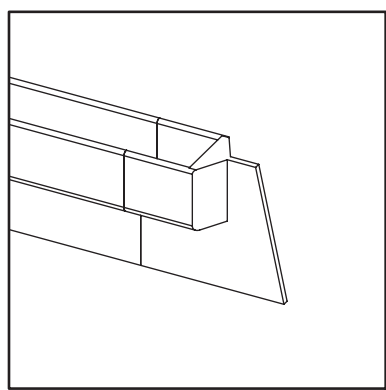
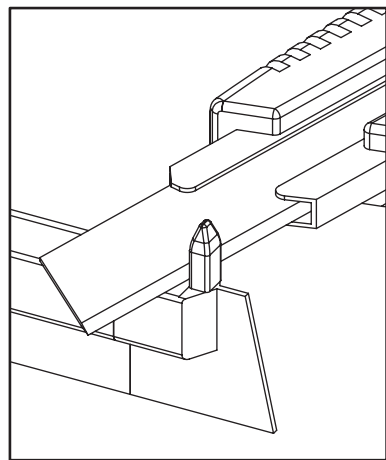
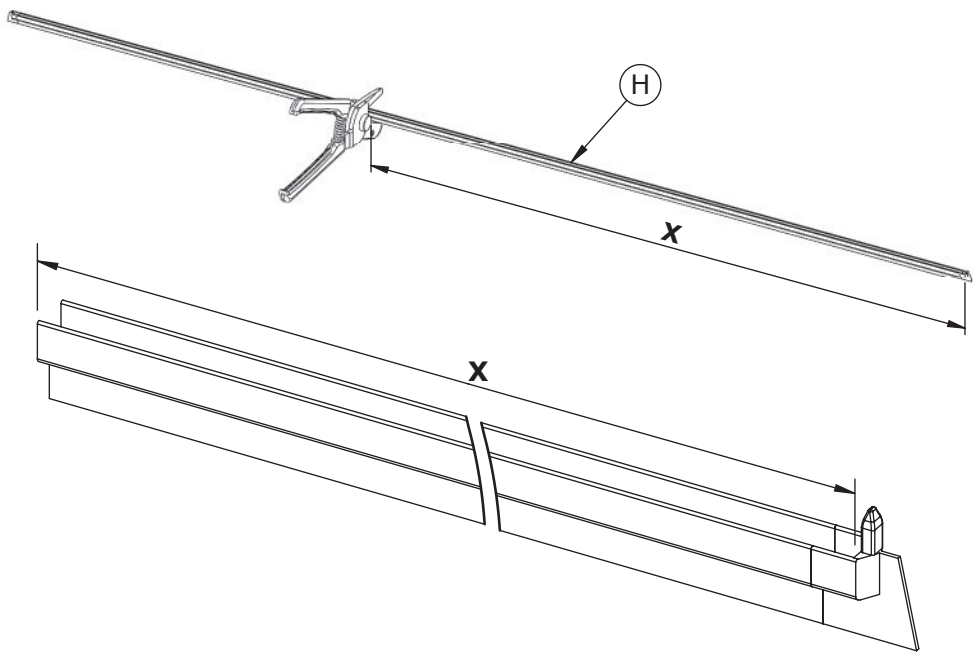

- Extérieur ① Outside
- Exterior ② Esterno
- Buitenkant ③ Außen

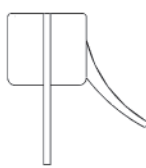

- Intérieur ④ Inside
- Interior ⑤ Interno
- Binnenkant ⑥ Innen

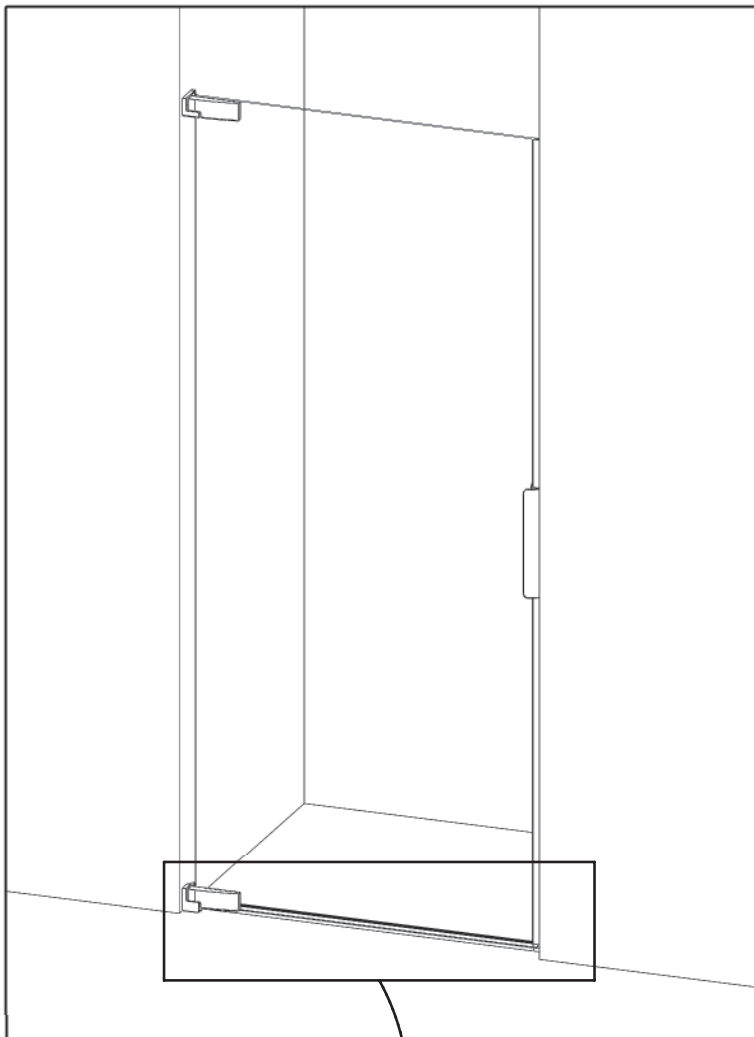

② Intérieur ② Inside ② Interior
 ① Interno ① Binnenkant ① Innen

③ Extérieur ③ Outside ③ Exterior
 ④ Esterno ④ Buitenkant ④ Außen

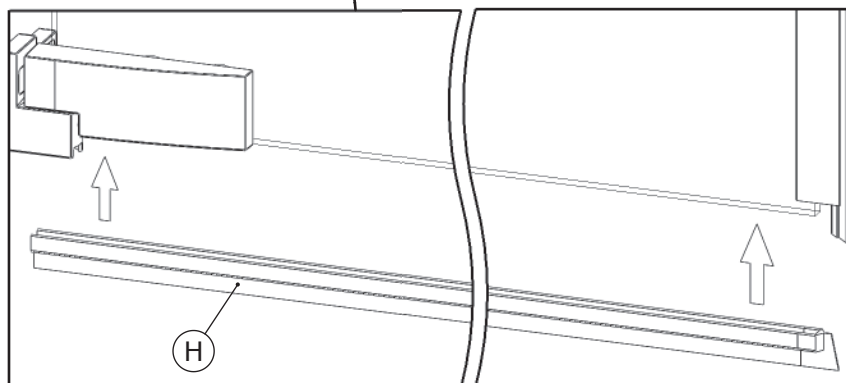

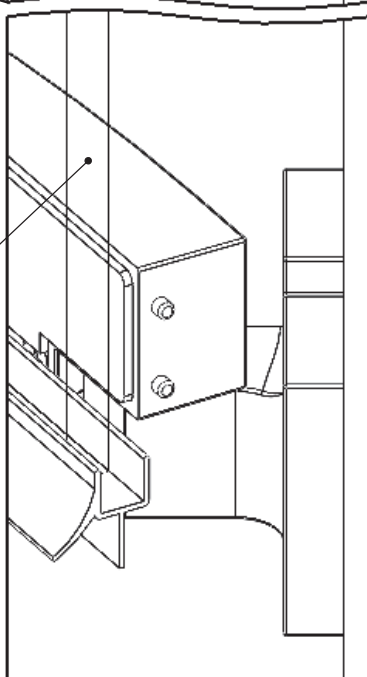
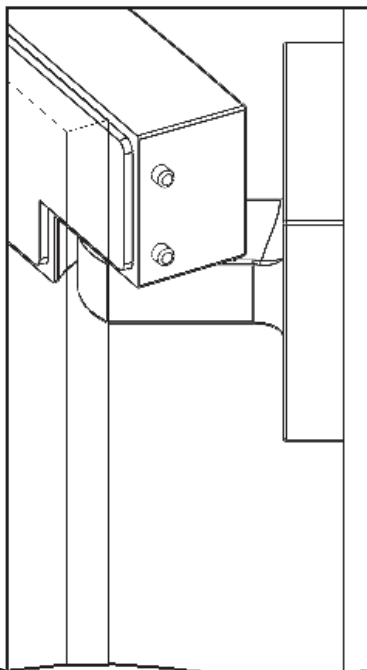
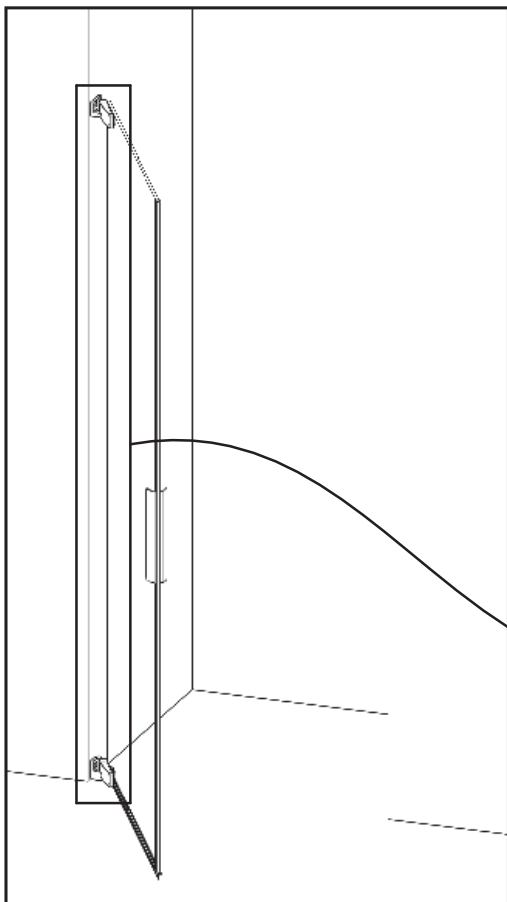

- Avant de coller le joint (I), la surface doit être nettoyée, dégraissée et sans poussière, avec un nettoyeur à base d'alcool.
- Before to put the seal (I), the surface must be cleaned, degreased and without dust, with alcohol based cleaner.
- Antes de poner la junta (I), la superficie debe limpiarse, desengrasa y sin polvo, con un limpiador a base de alcohol.
- Prima di incollare la guarnizioni (I), la superficie deve essere pulita, sgrassata e senza polvere, con un detergente a base di alcool.
- Vóór het lijmen van de afdichting (I), moet het oppervlak worden gereinigd, ontvet en stofvrij, met een basis van alcohol reinigingsmiddel.
- Bevor das Fugen zu kleben (I), soll die Oberfläche zu reinigen, entfetten und staubfrei, mit einem alkoholhaltigen Reinigungsmittel.

- Intérieur douche ● Inside shower
- Interior ducha ● Doccia interni
- Binnen douche
- Innenansicht der Kabine

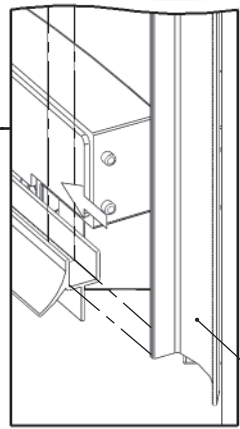
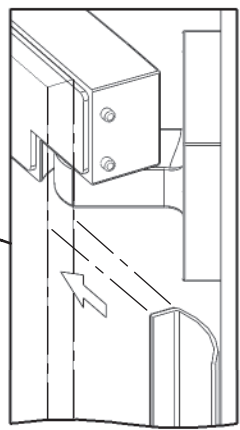
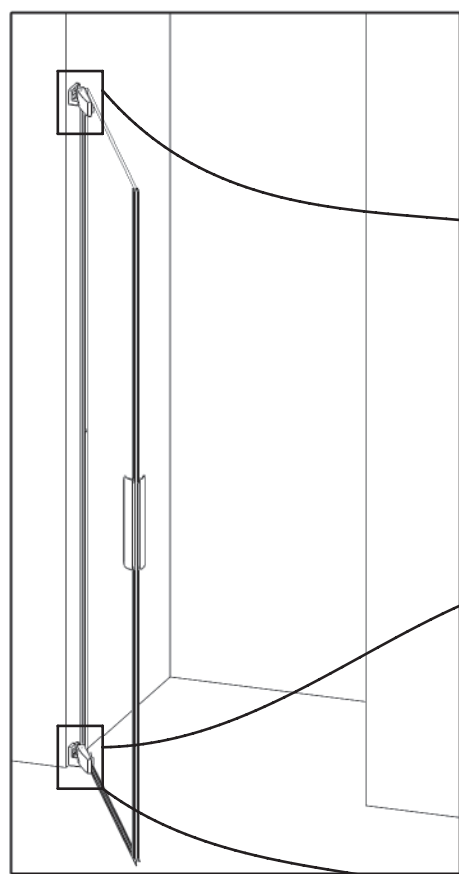
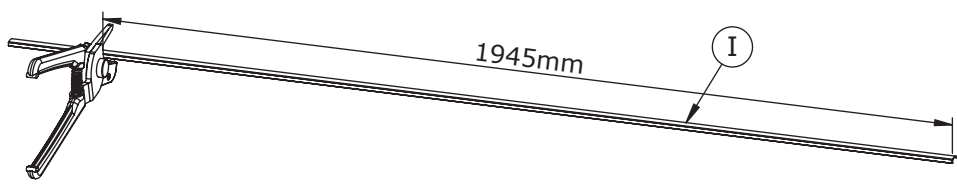

- Intérieur douche ● Interior shower ● Innenansicht der Kabine
- Doccia interni ● Binnen douche

- Retirer l'adhésif
- Remove adhesive
- Quitar el adhesivo
- Rimuovere il adesivo
- Lijm verwijderen
- Klebstoff entfernen

- Intérieur ● Inside
- Interior ● Interno
- Binnenkant ● Innen

- Extérieur ● Outside
- Exterior ● Esterno
- Buitenkant ● Außen

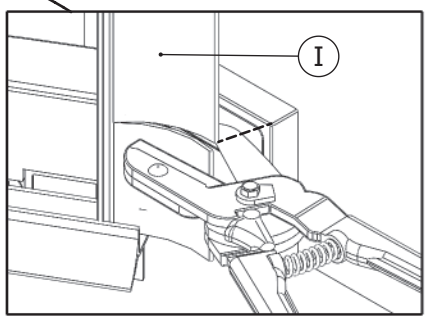
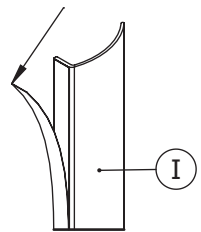

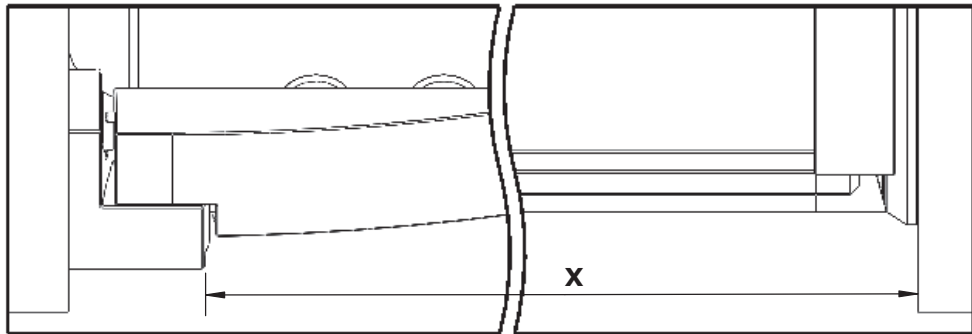
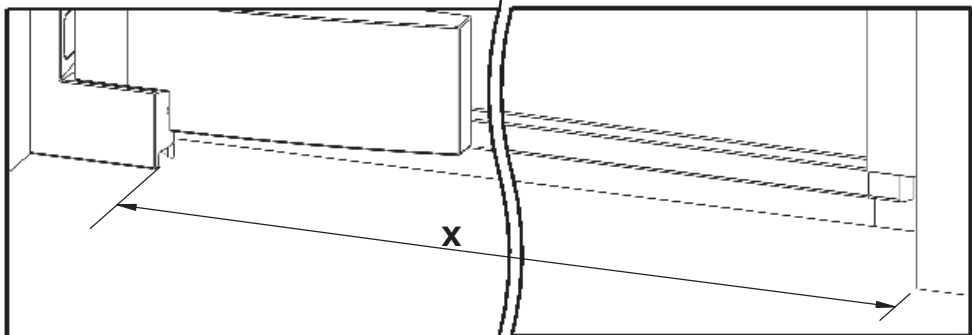
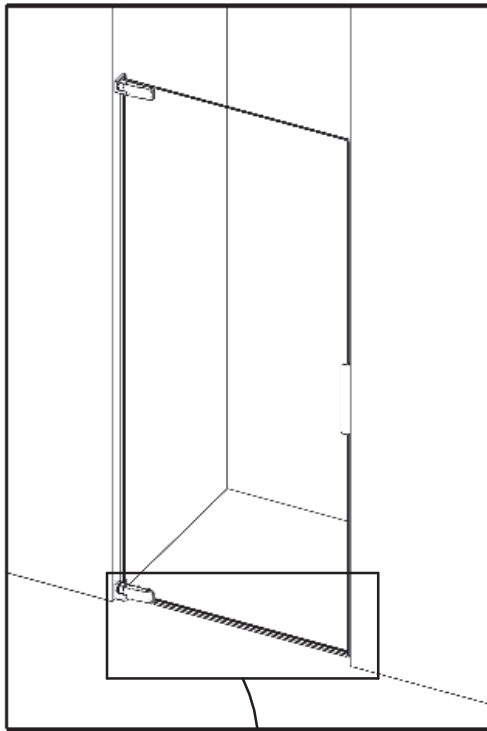

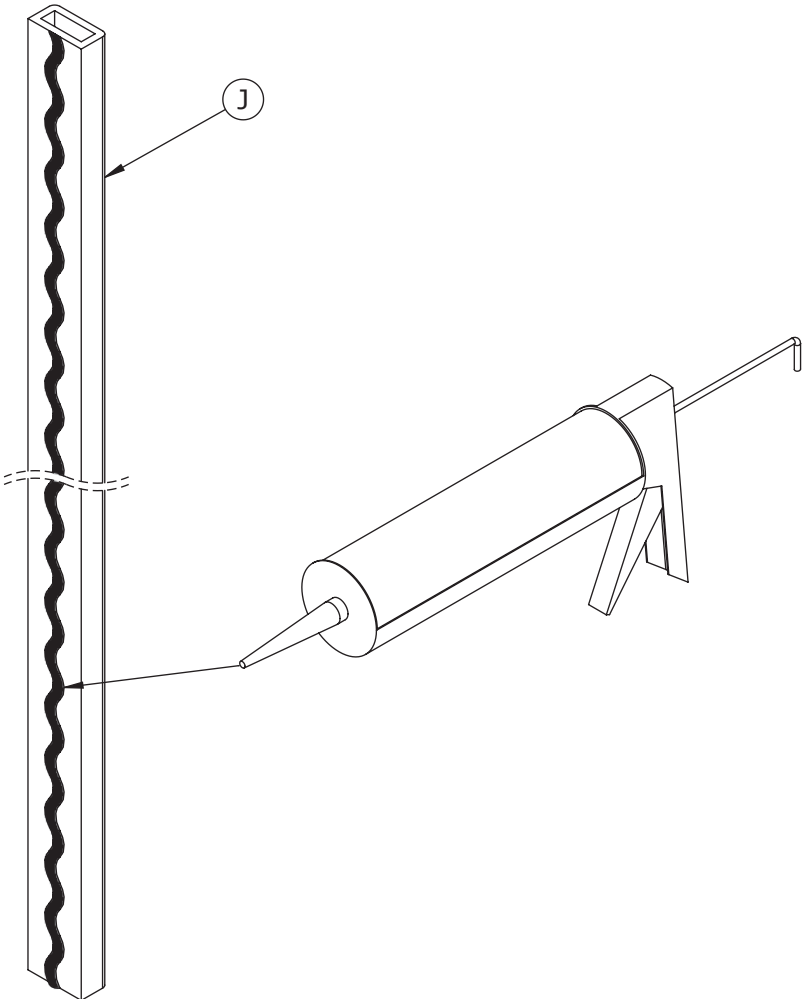
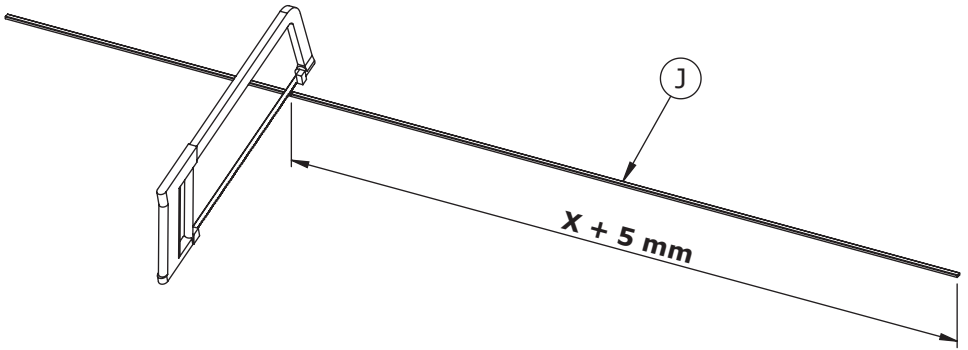

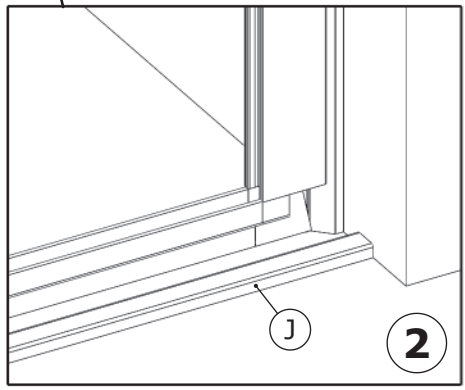
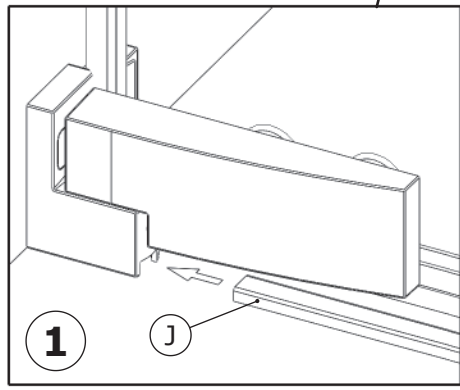
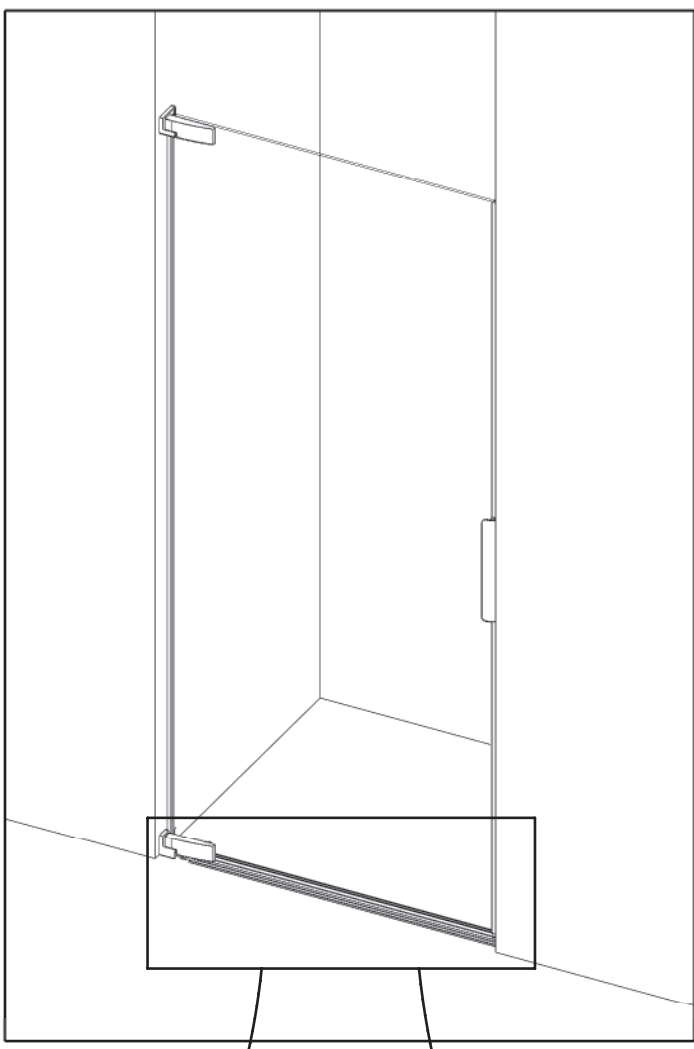

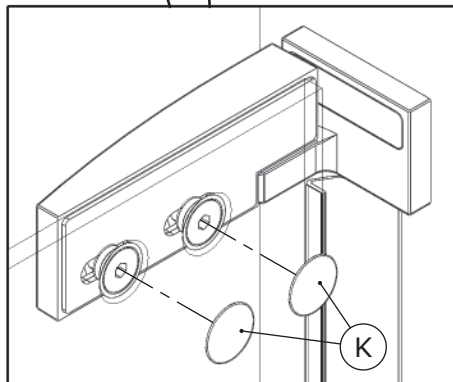
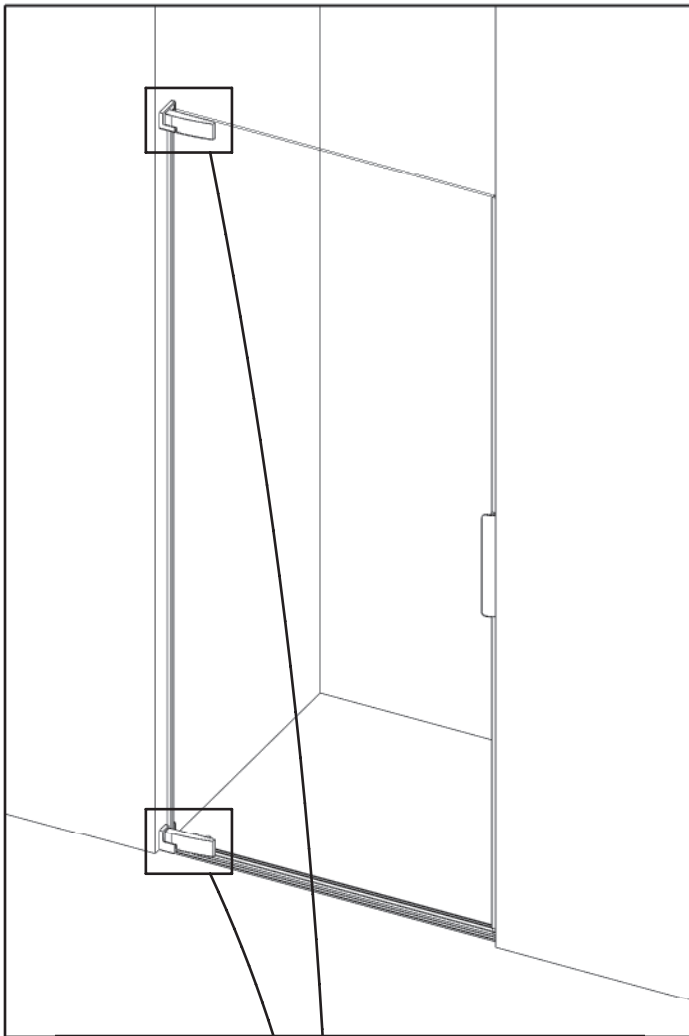

- Intérieur douche
- Inside shower
- Interior ducha
- Doccia interni
- Binnen douche
- Innenansicht der Kabine

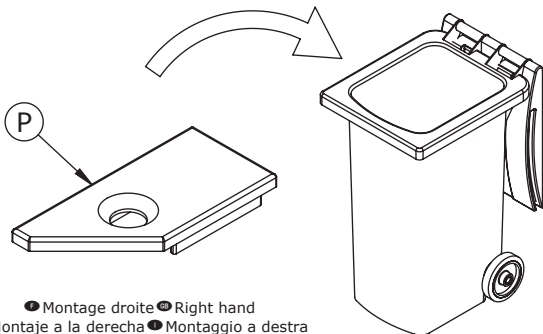
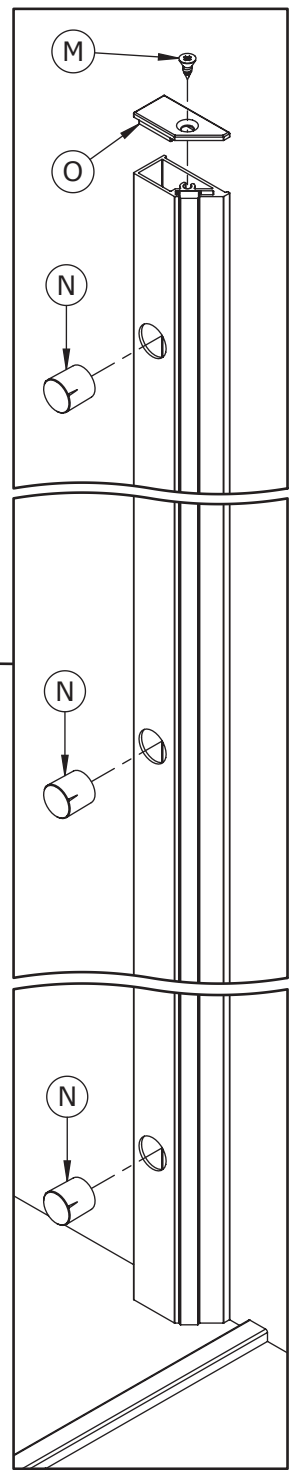
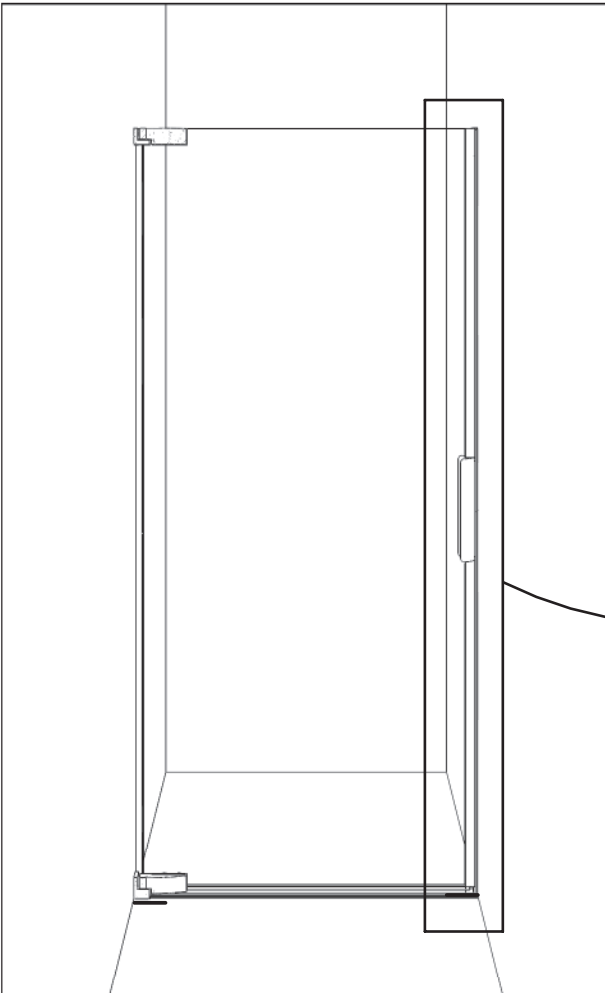

- Montage droite ● Right hand
- Montaje a la derecha ● Montaggio a destra
- Montage rechts ● Montage rechts

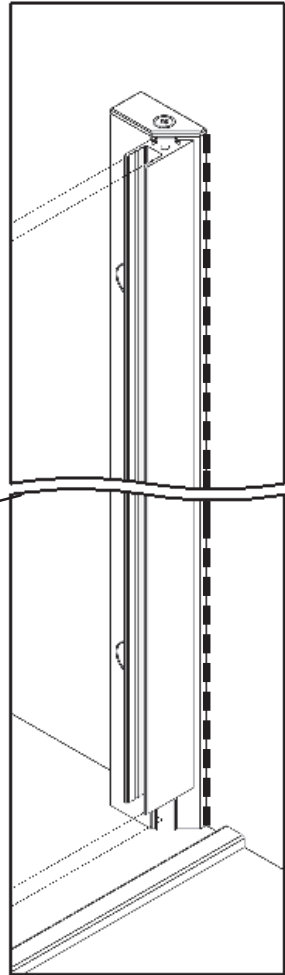
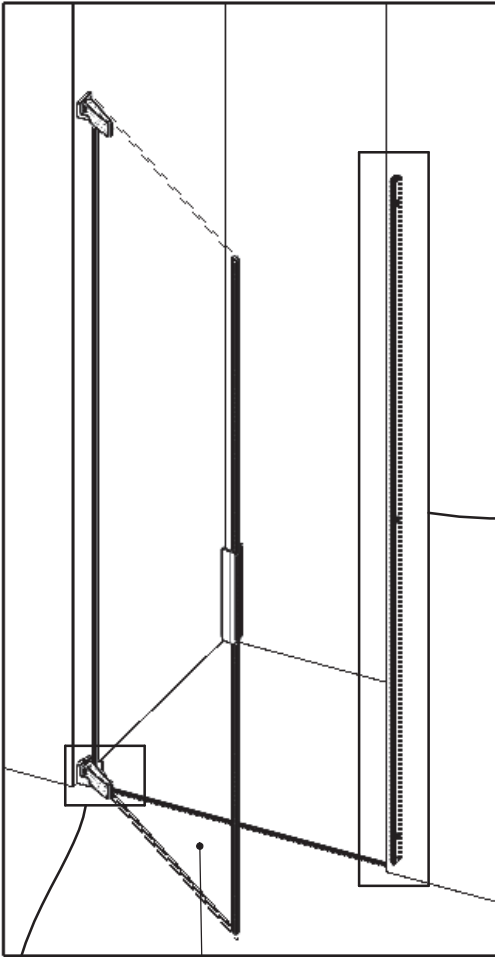

- Laisser la porte ouverte pendant le séchage.
- Let the door open during the drying time.
- Deje la puerta abierta durante el tiempo de secado.
- Lasciare la porta aperta durante il tempo di asciugatura.
- Laat de deur open tijdens de droogtijd.
- Lassen Sie die Tür während der Trocknungszeit geöffnet.

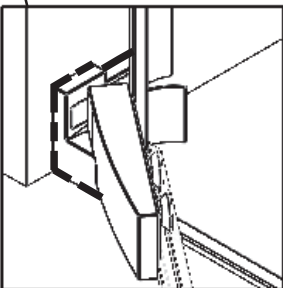

24H

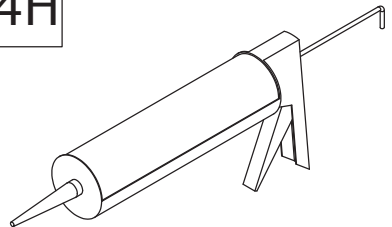



SAV
SERVICE HELPLINES
ASSISTENZA POST-VENDITA
SERVICIO POSTVENTA

FRANCE

02 40 21 29 45

UK

020 8842 0033

IRELAND

04697 33102

DEUTSCHLAND

+49 (0) 6074 /30928 0

ITALIA

(0382) 6181

OSTEREICH

+43 1 710 60 70

SCHWEIZ

(01) 748 17 44

ESPAÑA

93 544 60 76

NEDERLAND

0475 487 100

BELGIE

+31 475 487 100

BELGIQUE

+31 475 487 100

РОССИЯ

963 19 40, 773 67 22



AQUAPRODUCTION, Site industriel, F - 44680 Chéméré

16

EN 14428

Paroi de douche, fabriquée en verre de silicate
sodo-calcique de sécurité trempé thermiquement

Aptitude au nettoyage : réussite

Résistance à l'impact/propriétés de fragmentation : réussite

Durée : réussite