

- F Notice de montage ● GB Installation instructions
- E Manual de instalación ● I Istruzioni di montaggio
- NL Montage-instructies ● D Montageanleitung

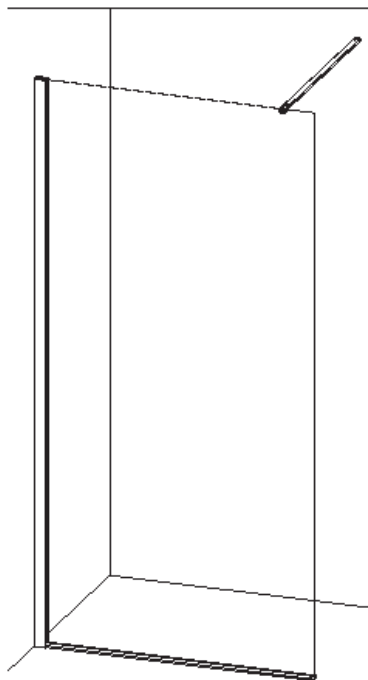

- F Attention aux étapes :
- GB Check installation steps :
- E Atención a los pasos :
- I Attenzione ai passi :
- NL Aandacht voor de stappen :
- D Achtung vor den Schritten :

P. 6 - 7 - 12

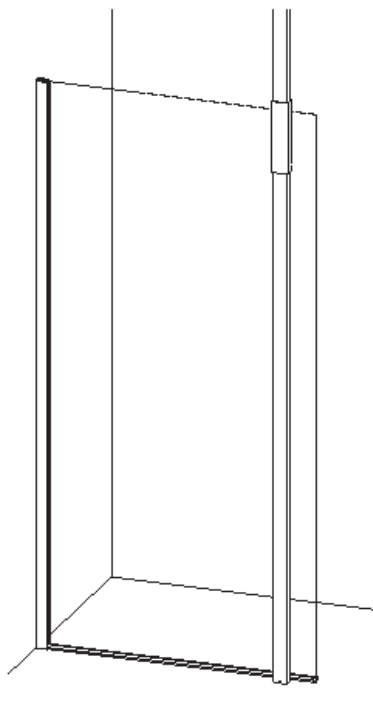
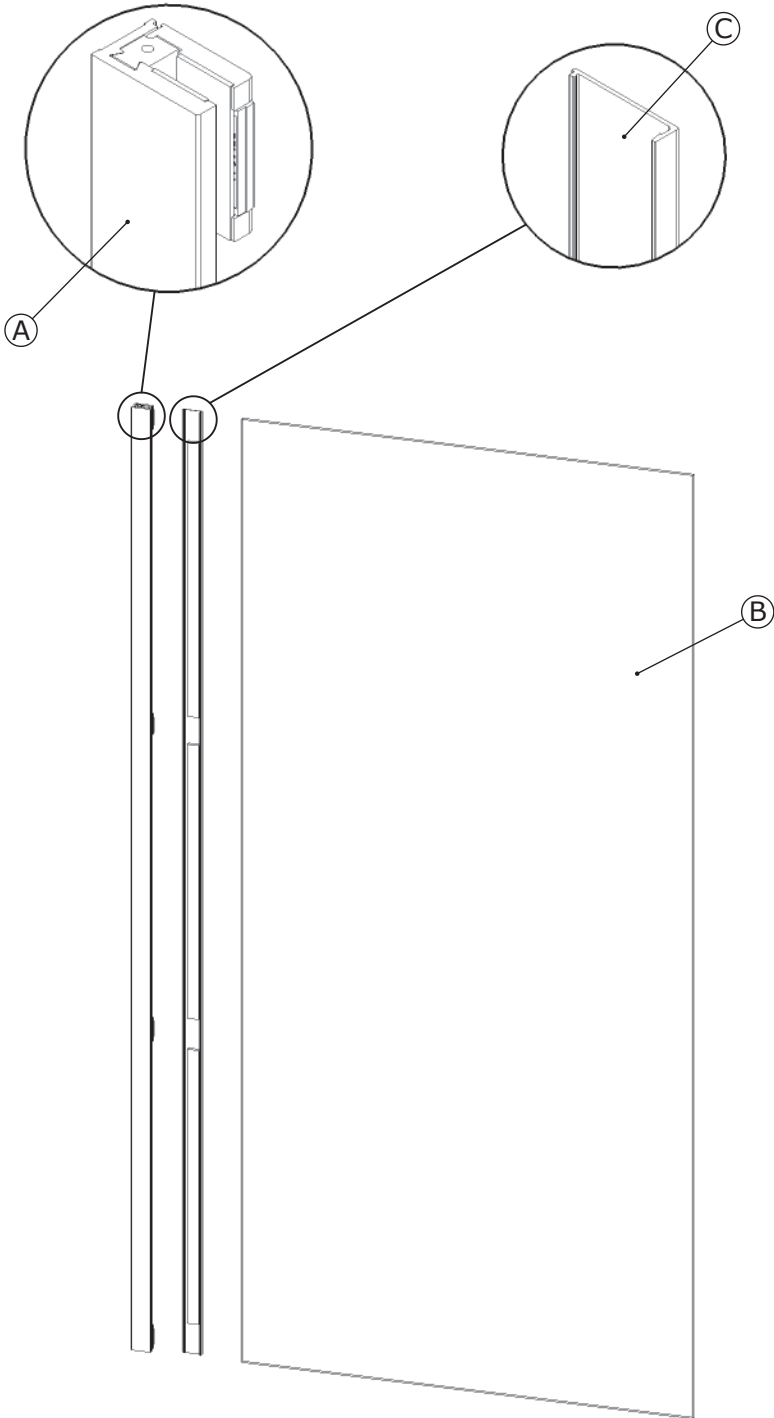

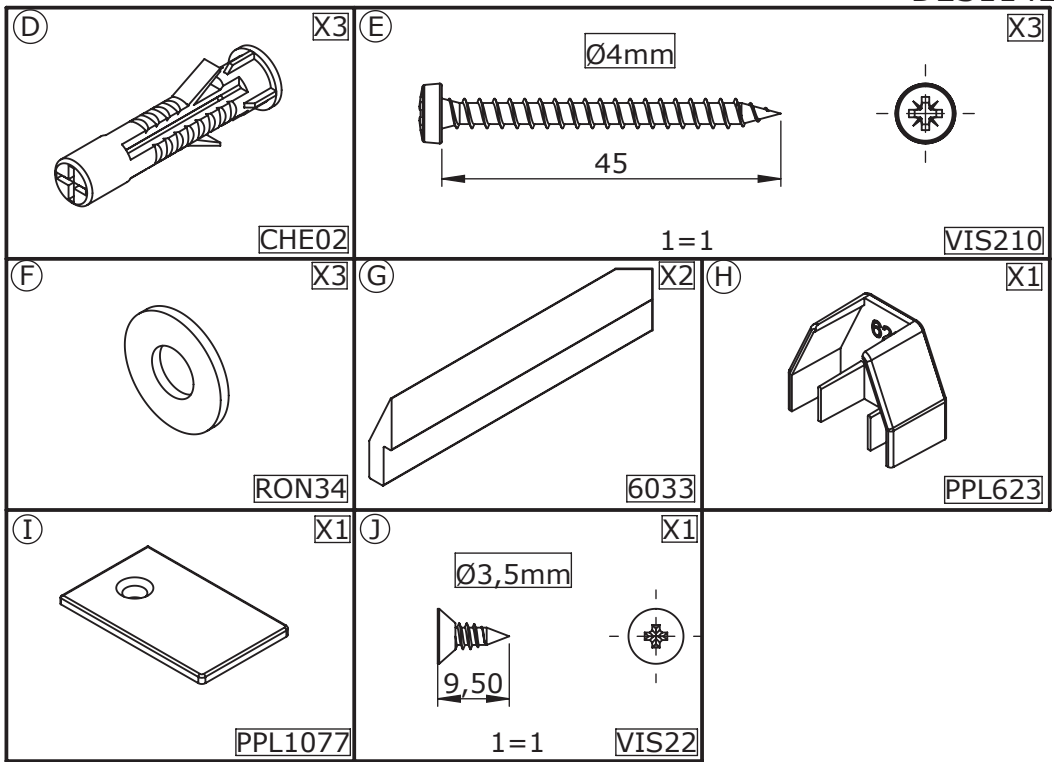

Les quantités données sont les quantités utiles au montage. les sachets fournis contiennent des pièces supplémentaires.
The quantities given are what are required for the installation. There may be some surplus in the package provide.

Matériel nécessaire
Tools required
Herramientas necesarias
Materiale necessario
Benodigd gereedschap
Werkzeuge Erforderlich

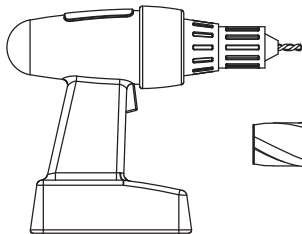

Ø6mm

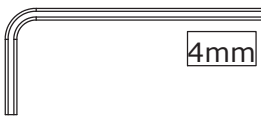
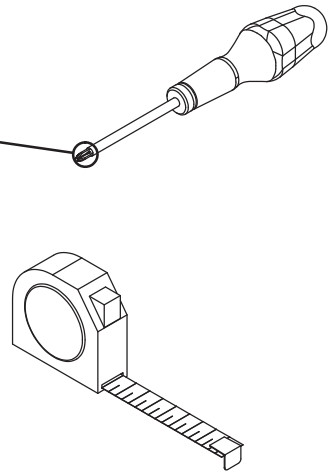
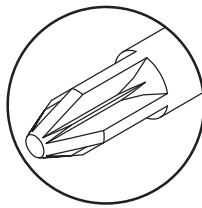

4mm

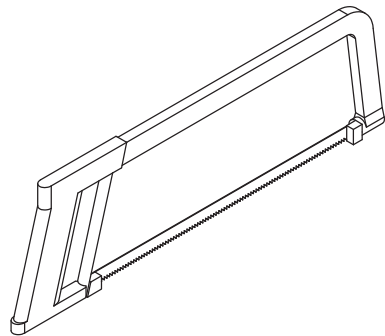
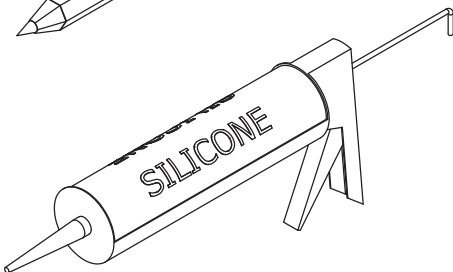
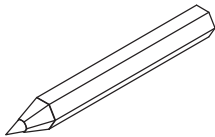
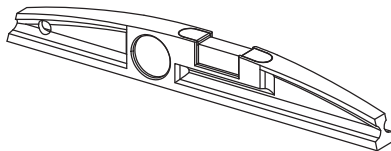

Utiliser un silicone adapté au matériau de chaque support (faïence, acrylique, etc.)
Use a silicone sealant that is intended for the surrounding materials (ceramic, acrylic, etc.)
Usar una silicona adecuada para cada tipo de material (loza, acrílico, etc.)
Utilizzare un silicone adatto a qualsiasi materiale (ceramica, acrilico, ecc.)
Gebruik siliconenkit die geschikt is voor iedere ondergrond (tegelwerk, acryl, etc.)
Für das jeweilige Trägermaterial (Stein, Acryl usw.) geeignetes Silikon verwenden.



REVERSIBILITE/REVERSIBILITY/REVERSIBILITA/REVERSIBILITA
MONTAGE OMKEREN/OMKEERBAARHEID/

MONTAGE A GAUCHE
LEFT HAND
MONTAGGIO A SINISTRA
MONTAJE A LA IZQUIERDA
MONTAGE LINKS
LINKSSEITIGE MONTAGE

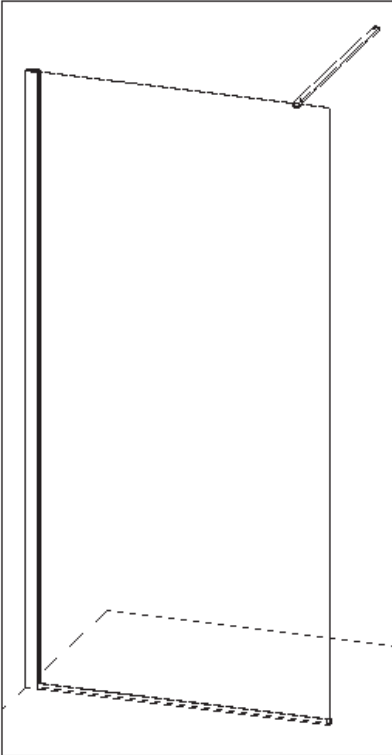

MONTAGE A DROITE
RIGHT HAND
MONTAGGIO A DESTRA
MONTAJE A LA DERECHA
MONTAGE RECHTS
RECHTSSEITIGE MONTAGE

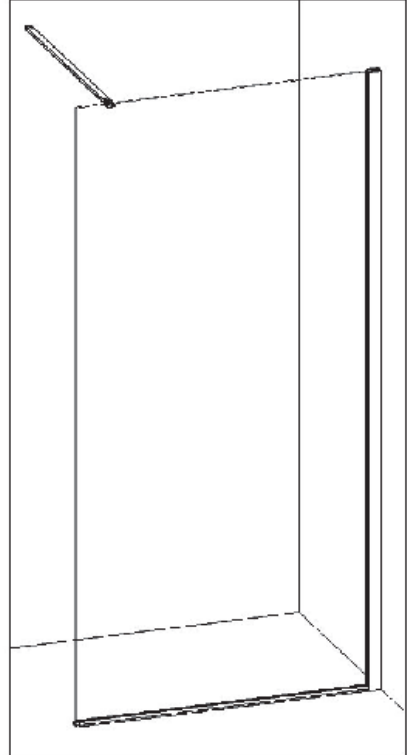

Vous avez la possibilité de réaliser un montage à droite ou un montage à gauche. Notre notice d'installation décrit un montage à gauche. si vous voulez réaliser un montage à droite, il vous suffit d'inverser le montage.

This cubicle can be installed either left or right hand. These installation instructions show a left hand installation.

Avete la possibilità di effettuare il montaggio a destra o a sinistra. Il nostro manuale descrive il montaggio a sinistra. Se volete realizzare il montaggio a destra è sufficiente invertire varie fasi di montaggio.

Puede realizar un montaje a la derecha o un montaje a la izquierda. Nuestro folleto de instalación describe un montaje a la izquierda. Si desea montar su cabina a la derecha sólo tendrá que realizar el montaje al contrario.

U kunt de cabine rechts of links monteren. Onze handleiding beschrijft de linkse montage van de cabine. Keer de montage om als u de cabine rechts wilt monteren.

Sie können eine rechtsseitige Montage oder eine Linksseitige Montage vornehmen. In unserer Montageanleitung wird eine linksseitige Montage beschrieben. Wenn Sie eine rechtsseitige montage vornehmen möchten, brauchen Sie lediglich die Montage umzukehren.

01

VUE INTERIEURE
INTERIOR VIEW
VISTA INTERIOR
VISTA INTERNA
BINNENZICHT
INNENANSICHT

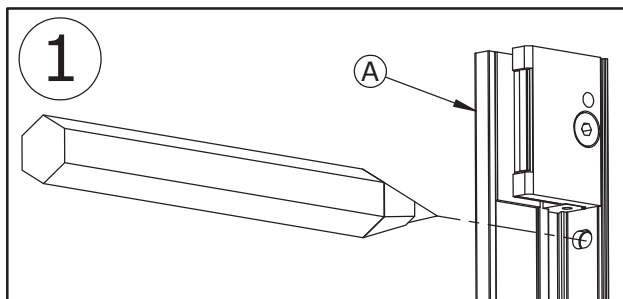

X3

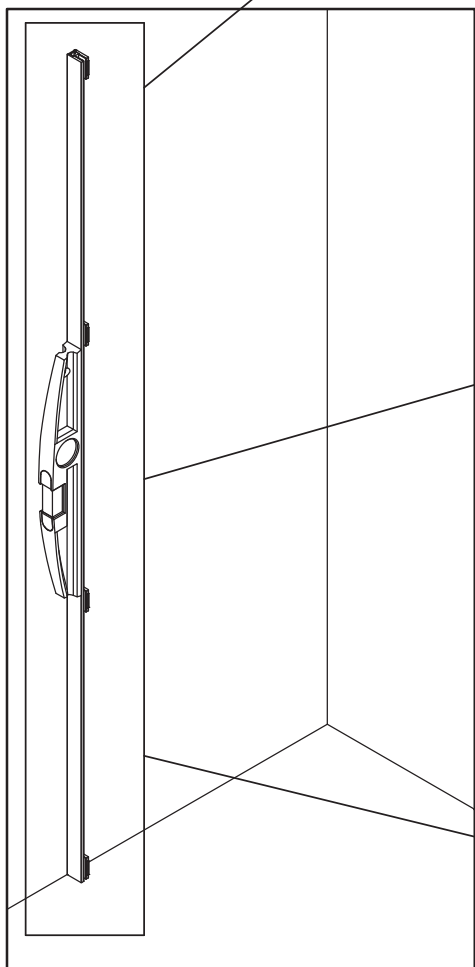

2

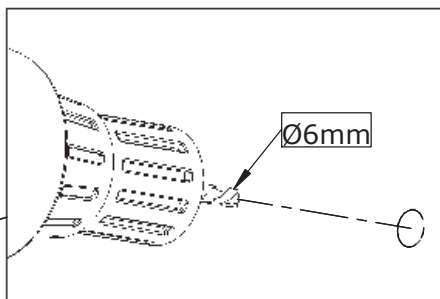

3

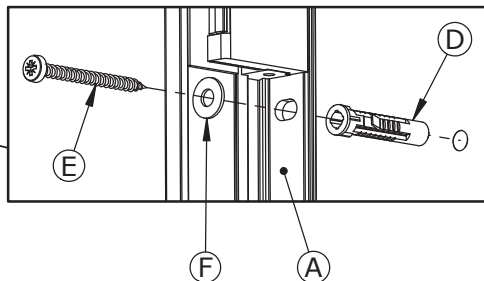

02

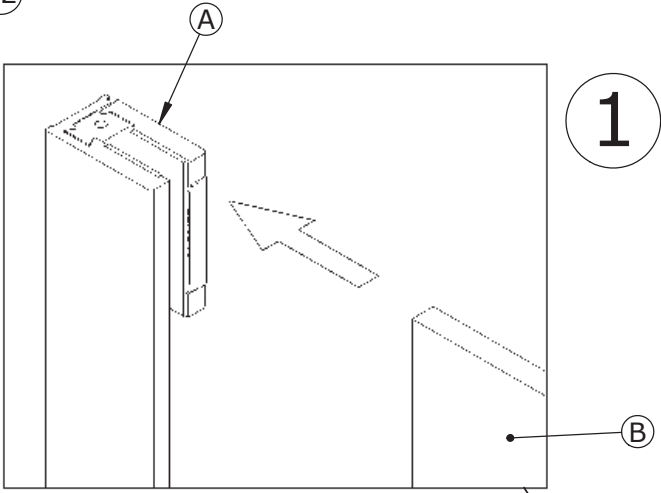

1

SERRER
TIGHTEN
APRIETE
SERRARE
AANDRAAIEN
FASTSIEHEN

2

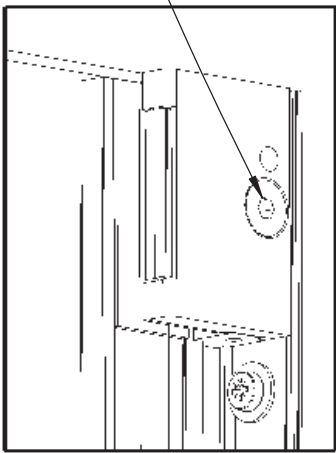

X4

VUE INTERIEURE
INTERIOR VIEW
VISTA INTERIOR
VISTA INTERNA
BINNENZICHT
INNENANSICHT

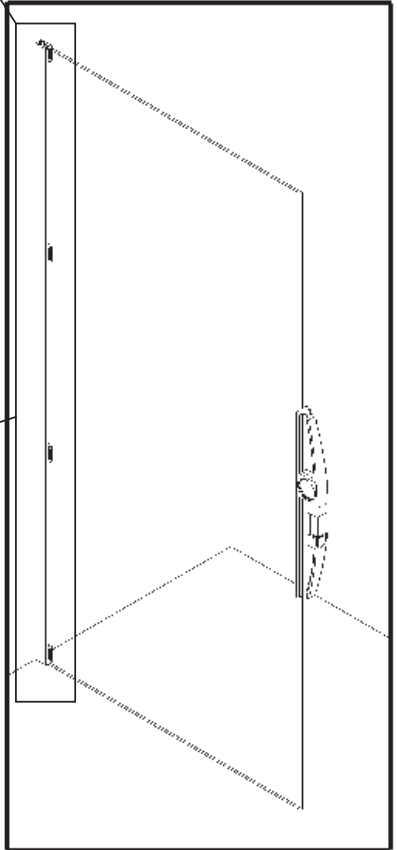

03

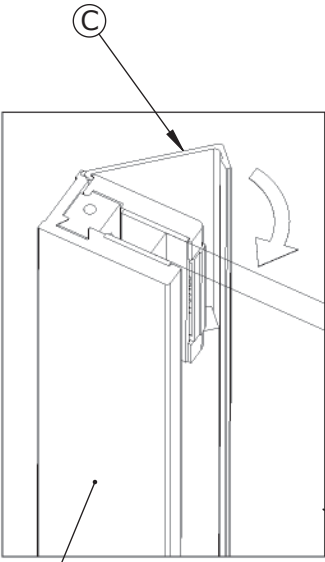

A

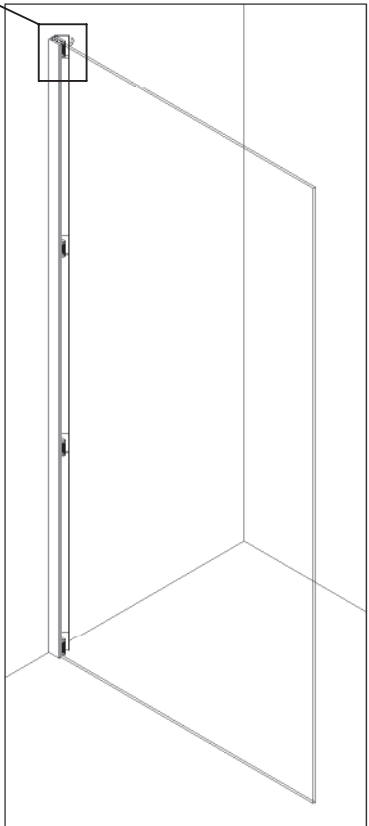

04

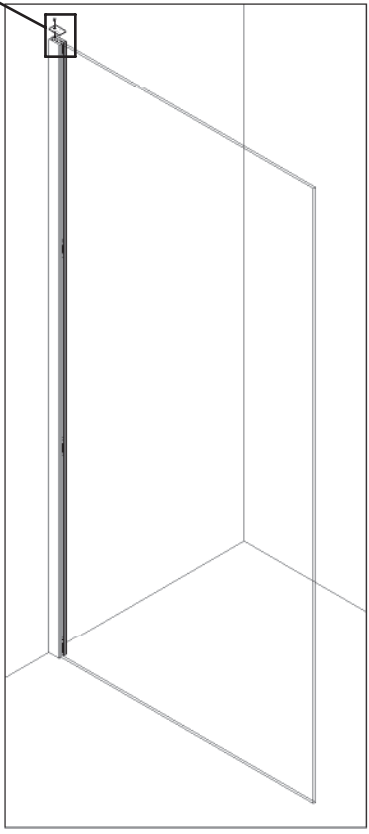
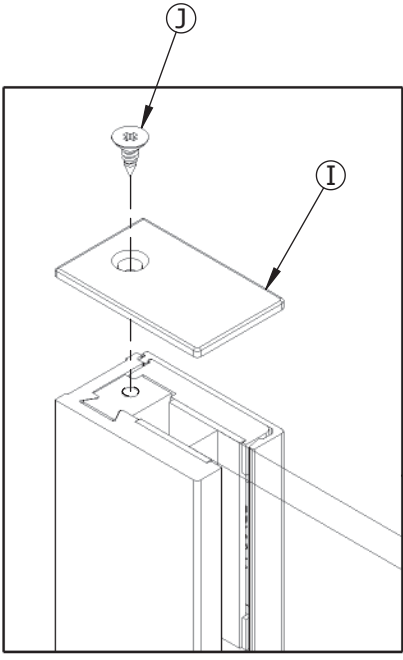

05

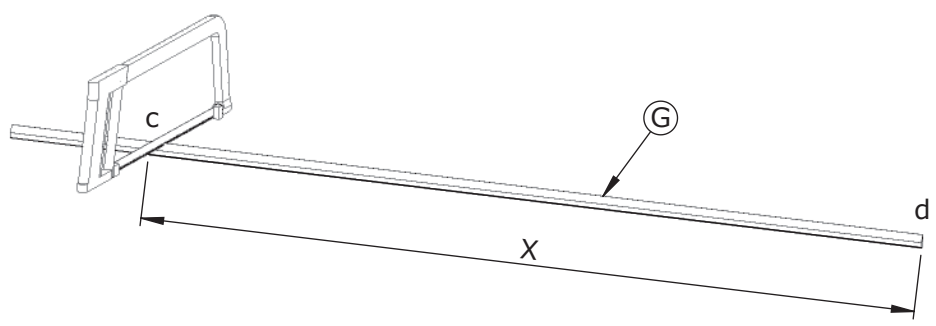
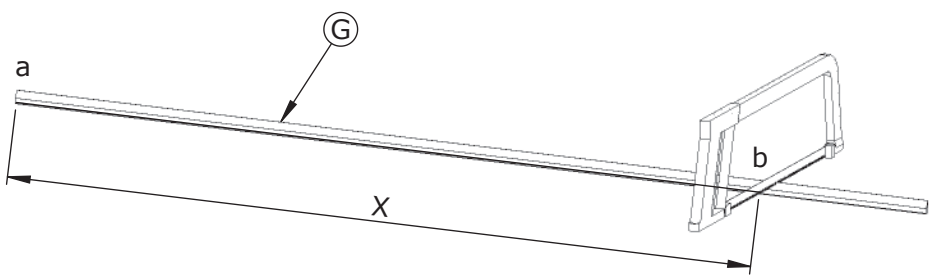
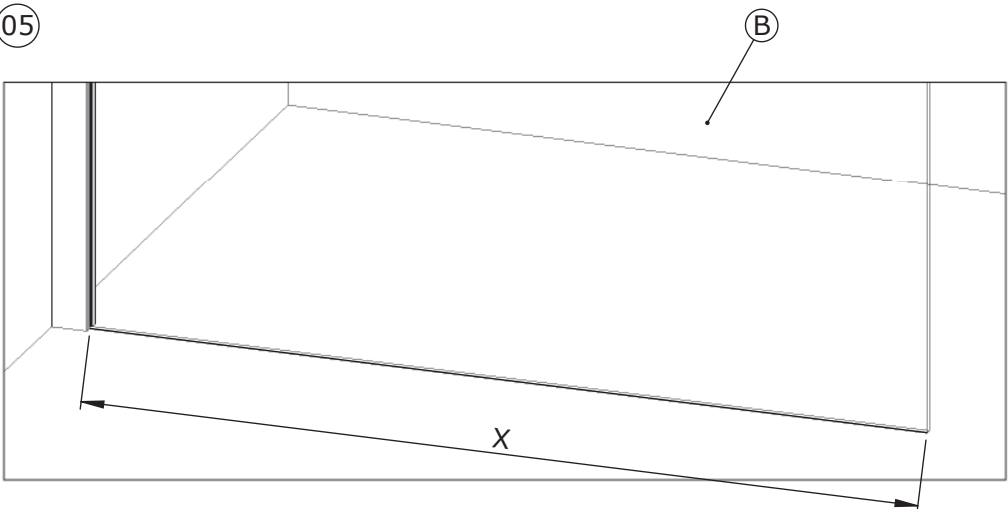

06

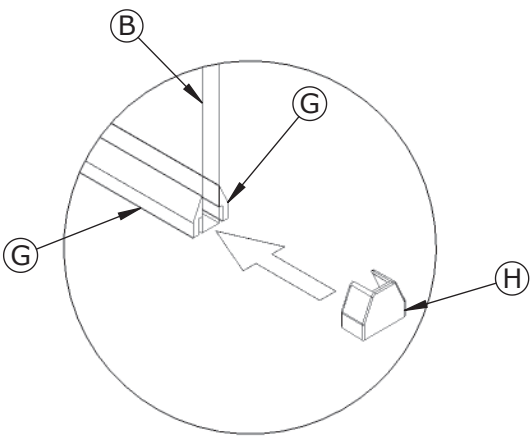
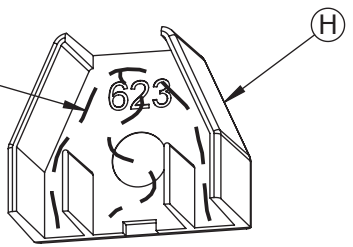
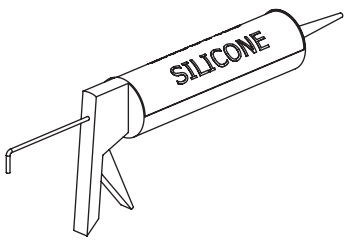
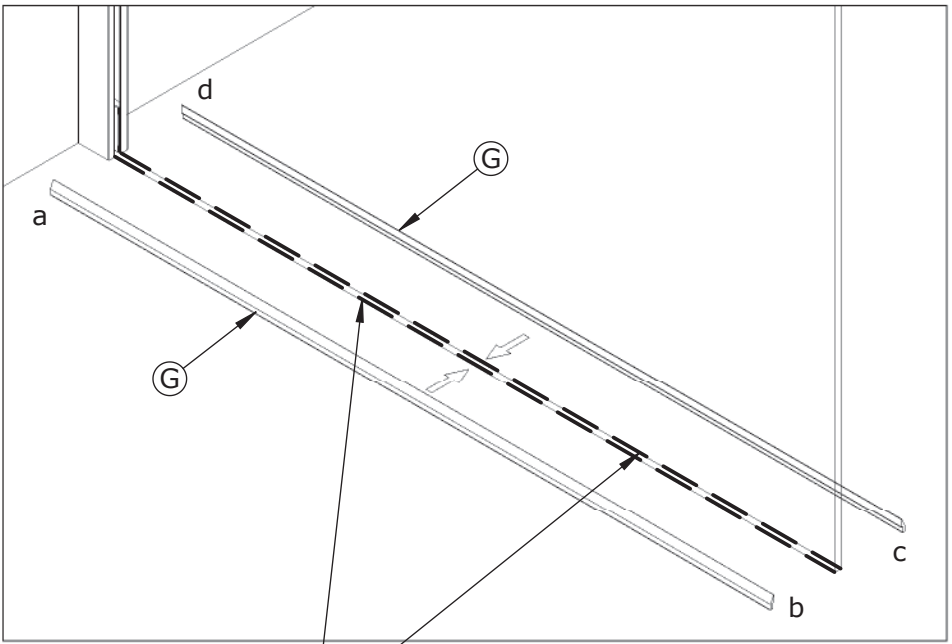

07



24H

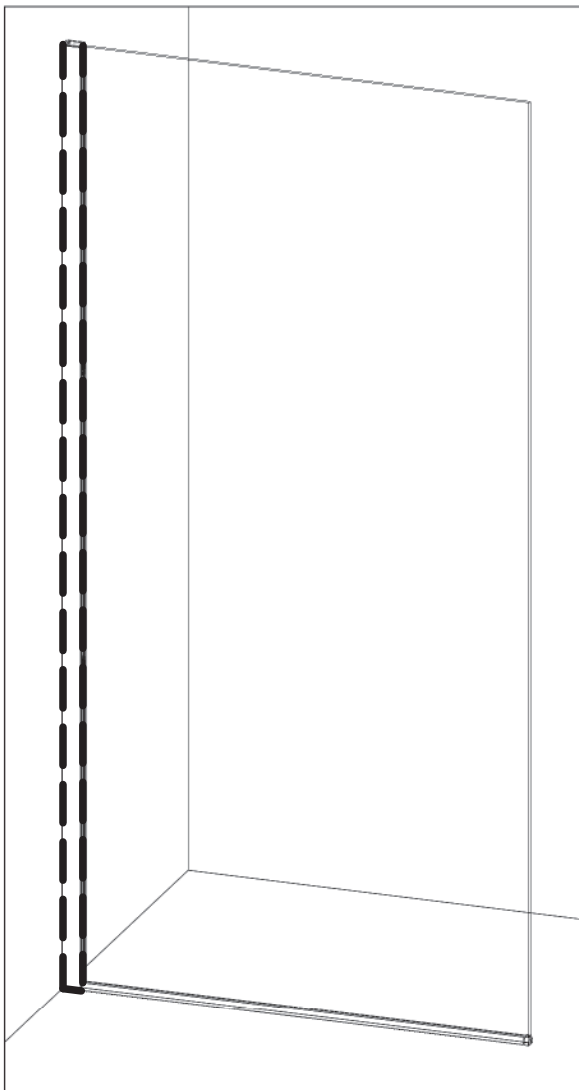

08

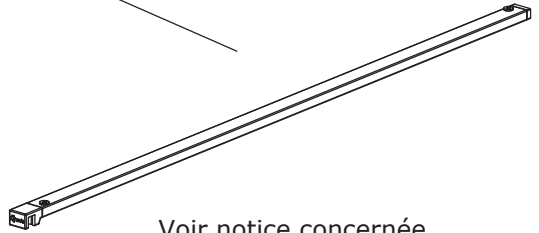
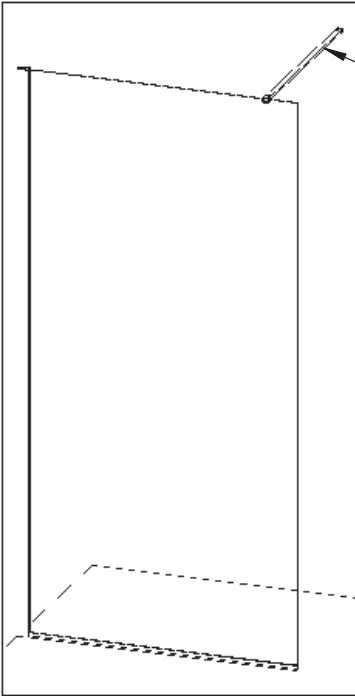

Voir notice concernée
See installation instructions required
Ver manual adecuado
Vedere manuale appropriato
Zie montage-instructies
Siehe betreffende Anleitung

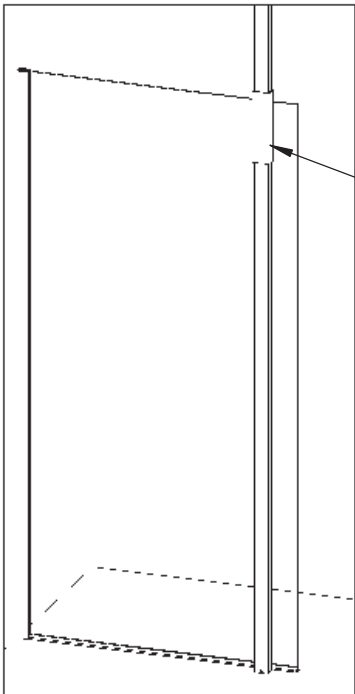



AQUAPRODUCTION, Site industriel, F - 44680 Chéméré

17

EN 14428

Paroi de douche, fabriquée en verre de silicate
sodo-calcique de sécurité trempé thermiquement

Aptitude au nettoyage : réussite

Résistance à l'impact/propriétés de fragmentation : réussite

Durée : réussite



SAV
SERVICE HELPLINES
ASSISTENZA POST-VENDITA
SERVICIO POSTVENTA

FRANCE

02 40 21 29 45

SCHWEIZ

(01) 748 17 44

UK

020 8842 0033

ESPANA

93 544 60 76

IRELAND

04697 33102

NEDERLAND

0475 487 100

DEUTSCHLAND

+49 (0) 6074 / 30928 0

BELGIE

+31 475 487 100

ITALIA

(0382) 6181

BELGIQUE

+31 475 487 100

OSTEREICH

+43 1 710 60 70

РОССИЯ

963 19 40, 773 67 22