

*KineStyle*

**AQUALIGHT**

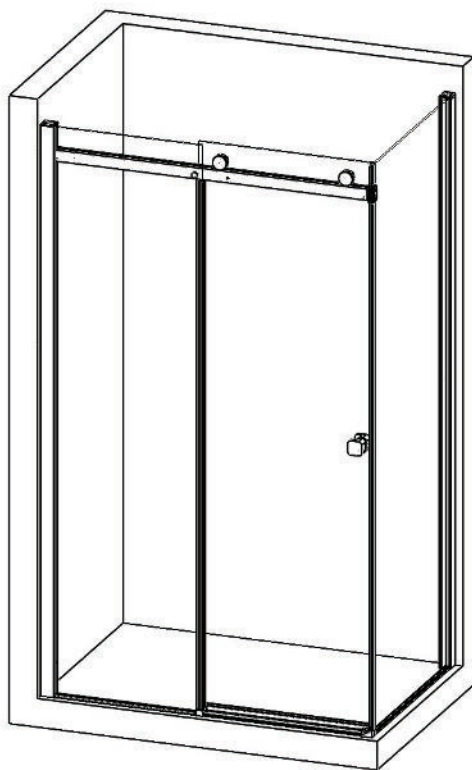

Instructions de montage- FR  
Nettoyage et entretien-

.....  
Istruzioni di montaggio- IT  
Pulizia e manutenzione-

.....  
Montageinstructies- NL  
Reiniging en onderhoud-

.....  
Instrucciones de montaje- ES  
Limpieza y mantenimiento-

.....  
Montageanweisungen- D  
Reinigung und wartung-

DES1053E

**Avant l'installation  
Prima dell'installazione  
Voor de installatie  
Antes de la instalación  
Vor der Installation**



Nous vous remercions d'avoir  
choisi notre produit

Vi ringrazioma per aver scelto un  
nostro prodotto

Wij danken u dat u voor ons  
product heeft gekozen

Le agradecemos que haya elegido  
un producto nuestro

Vielen Dank, dass Sie sich für  
unser Produkt entschieden haben

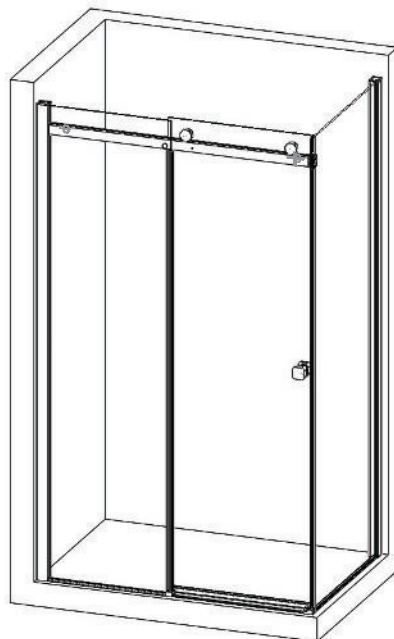

**FR** **IMPORTANT**  
Avant de commencer l'installation,  
lire ce livret d'instructions.

**IT** **IMPORTANTE**  
Prima di iniziare l'installazione  
leggere il presente libretto istruzioni.

**IT** **BELANGRIJK**  
Lees dit instructieboekje voordat  
u met de installatie begint.

**IT** **IMPORTANTE**  
Antes de empezar con la instalación  
lea el manual de instrucciones.

**D** **WICHTIG**  
Lesen Sie diese Bedienungsanleitung,  
bevor Sie mit der Installation beginnen

**Avant l'installation**  
**Prima dell'installazione**  
**Voor de installatie**  
**Antes de la instalación**  
**Vor der Installation**

- FR**
- Une fois les composants retirés des emballage, vérifier visuellement qu'ils soient sans défaut.
  - Signaler tout défaut au fournisseur avant l'assemblage des différentes parties de l'installation.
  - Il ne sera possible d'accepter les réclamations relatives à des imperfections du produit qu'A CONDITION que celles-ci soient signalées avant l'assemblage des différentes parties et avant l'installation.
- .....

- IT**
- Dopo aver rimosso i componenti dagli imballi, verificare visivamente che gli stessi non presentino difetti.
  - Qualsiasi difetto deve essere segnalato al fornitore prima dell'assemblaggio delle varie parti e dell'installazione.
  - Qualsiasi reclamo relativo a imperfezioni del prodotto sarà accettato SOLO se segnalato prima dell'assemblaggio delle varie parti e dell'installazione.
- .....

- NL**
- Controleer visueel na de onderdelen uit de verpakking te hebben gehaald of de componenten defecten vertonen.
  - Elk defect moet worden gemeld aan de leverancier vóór montage van de verschillende onderdelen en installatie.
  - Eventuele klachten over onvolmaaktheden van het product worden UITSLUITEND geaccepteerd indien gemeld vóór de montage van de verschillende onderdelen en installatie.
- .....

- ES**
- Después de haber quitado los embalajes, comprobar visualmente que los componentes no presenten defectos.
  - Cualquier defecto debe ser indicado al proveedor antes del ensamblaje de las diferentes partes y de la instalación, en un plazo de 24 horas.
  - Cualquier reclamación relativa a imperfecciones del producto será aceptada SOLAMENTE si se indica antes del ensamblaje de las diferentes partes y de la instalación, dentro del plazo indicado.
- .....

- D**
- Führen Sie, nachdem alle Bestandteile ausgepackt sind, eine Sichtprüfung durch, um sicherzustellen, dass sie keine Mängel aufweisen.
  - Melden Sie eventuelle Mängel dem Lieferanten, bevor Sie die verschiedenen Teile montieren.
  - Beanstandungen von Produktmängeln können NUR DANN akzeptiert werden, wenn sie vor der Montage der verschiedenen Teile und vor dem Einbau gemeldet werden.

**Table des matières**  
**Indice**  
**Inhoudstafel**  
**Índice**  
**Inhaltsverzeichnis**

|           |                                  |         |
|-----------|----------------------------------|---------|
| <b>FR</b> | - Composants fournis             | Pag. 5  |
|           | - Séquence de montage            | Pag. 13 |
|           | - Informations sur l'utilisation | Pag. 42 |
|           | - Nettoyage et entretien         | Pag. 44 |

|           |                              |         |
|-----------|------------------------------|---------|
| <b>IT</b> | - Componenti forniture       | Pag. 5  |
|           | - Sequenza di montaggio      | Pag. 13 |
|           | - Informazioni sull'utilizzo | Pag. 42 |
|           | - Pulizia e manutenzione     | Pag. 44 |

|           |                               |         |
|-----------|-------------------------------|---------|
| <b>NL</b> | - Geleverde onderdelen        | Pag. 5  |
|           | - Montagevolgorde             | Pag. 13 |
|           | - Informatie over het gebruik | Pag. 42 |
|           | - Reiniging en onderhoud      | Pag. 44 |

|           |                              |         |
|-----------|------------------------------|---------|
| <b>ES</b> | - Componentes entregados     | Pag. 5  |
|           | - Secuencia de montaje       | Pag. 13 |
|           | - Informaciones sobre el uso | Pag. 42 |
|           | - Limpieza y mantenimiento   | Pag. 44 |

|          |                                     |         |
|----------|-------------------------------------|---------|
| <b>D</b> | - Gelieferte Komponenten            | Pag. 5  |
|          | - Montagereihenfolge                | Pag. 13 |
|          | - Informationen über die Verwendung | Pag. 42 |
|          | - Reinigung und Wartung             | Pag. 44 |



Exécuter l'installation et l'assemblage  
de la cabine en respectant la séquence illustrée



Eseguire l'installazione e l'assemblaggio della cabina  
chiusura rispettando la sequenza illustrata.



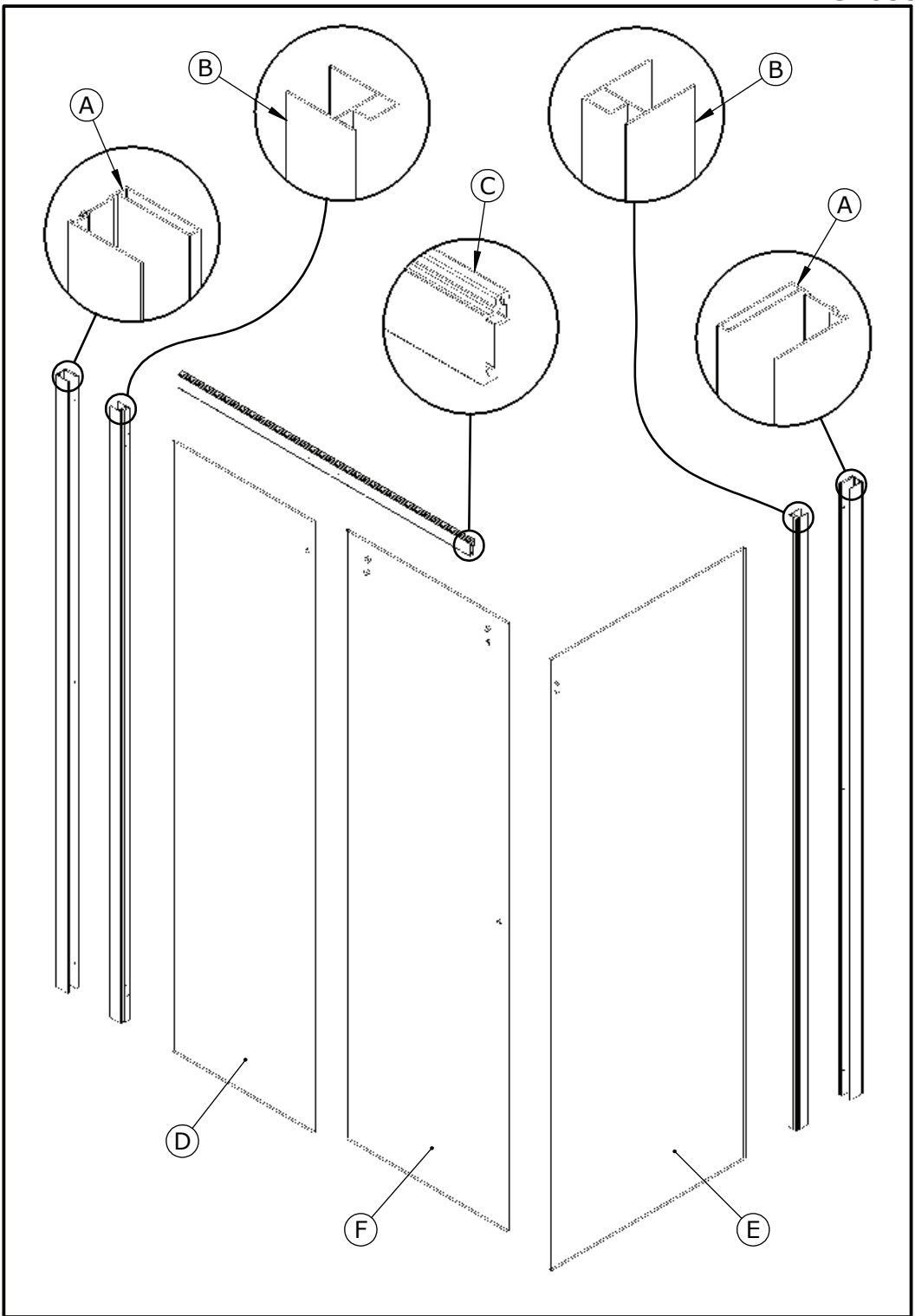

Voer de installatie en montage van de douchecabine  
in de aangegeven volgorde uit

Realizar la instalación y el ensamblaje de la cabina  
respetando la secuencia ilustrada.



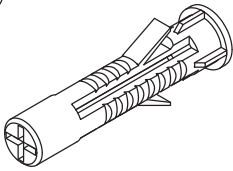
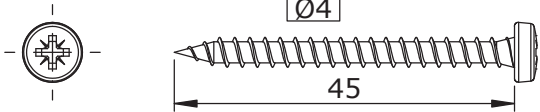

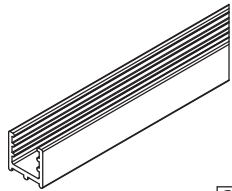
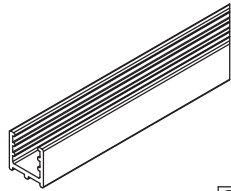
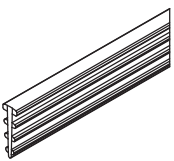
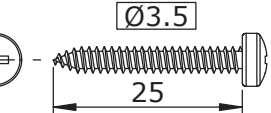
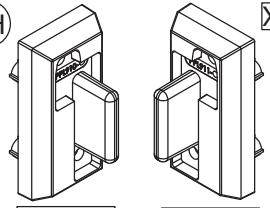
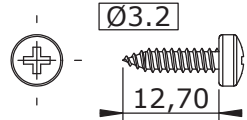
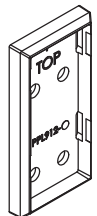
Führen Sie den Einbau und Montage der Kabine  
in der angegebenen Reihenfolge durch

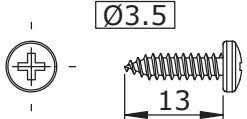
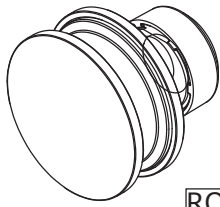
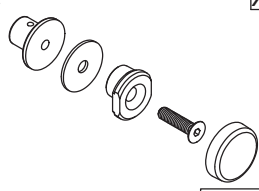
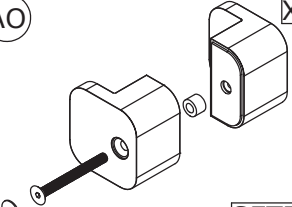
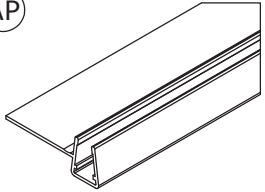
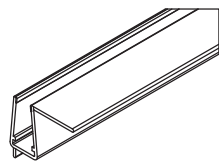

## DES1053E

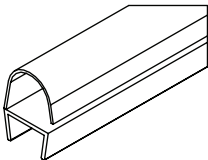
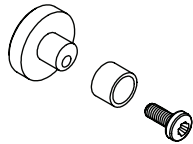
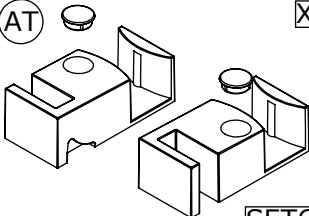
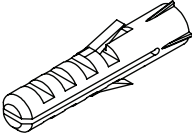
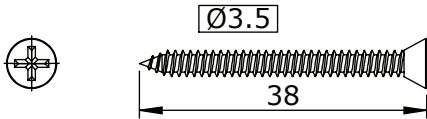
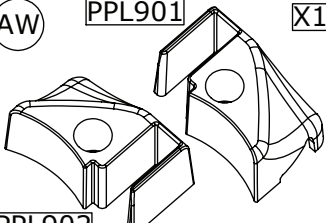
|  |  |  |
|--|--|--|
| <p>AA X6</p>  <p>CHE02</p>            | <p>AC X6</p>  <p>1=1 VIS210</p>       |  |
| <p>AB X6</p>  <p>RON05</p>          | <p>AD X1</p>  <p>6142</p>             | <p>AE X1</p>  <p>6142</p>          |
| <p>AF X2</p>  <p>Lg=1984mm J637</p> | <p>AG X4</p>  <p>1=1 VIS3.5x25</p>    | <p>AH X1</p>  <p>PPL910 PPL911</p> |
| <p>AI X2</p>  <p>1=1 VIS3.2x12.7</p> | <p>AJ X1</p>  <p>PPL912</p>          | <p>AK X1</p>  <p>PPL913</p>        |
| <p>AL X6</p>  <p>1=1 VIS117</p>    | <p>AM X2</p>  <p>ROU40</p>          | <p>AN X2</p>  <p>SET66</p>       |
| <p>AO X1</p>  <p>SET70</p>         | <p>AP X1</p>  <p>Lg=1863mm J636</p> | <p>AQ X1</p>  <p>JOI258</p>      |

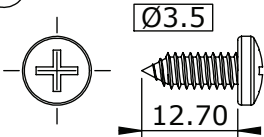
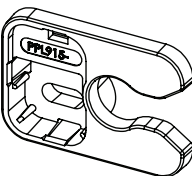
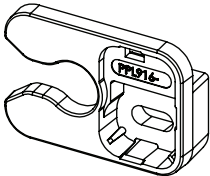
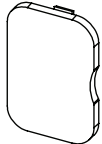
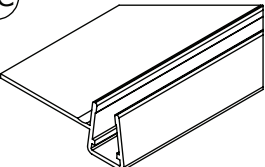
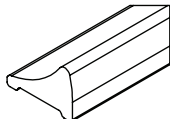
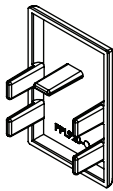
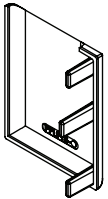
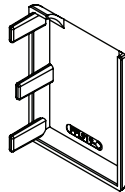
Les quantités données sont les quantités utiles au montage. Les sachets fournis contiennent des pièces supplémentaires.  
The quantities given are what are required for the installation. There may be some surplus in the package provide.

|  |  |  |
|--|--|--|
| <p>AR X1</p>  <p>J645</p>                    | <p>AS X1</p>  <p>SET68</p>             | <p>AT X1</p>  <p>SET65</p>              |
| <p>AU X2</p>  <p>CHE03</p>                  | <p>AV X2</p>  <p>1=1</p> <p>VIS42</p> |  |
| <p>AW PPL901 X1</p>  <p>PPL902</p>           | <p>AX X8</p>  <p>CAP19</p>            | <p>AY X2</p>  <p>1=1</p> <p>VIS132</p> |
| <p>AZ X1</p>  <p>PPL915</p>                | <p>BA X1</p>  <p>PPL916</p>          | <p>BB X2</p>  <p>PPL917</p>             |
| <p>BC X1</p>  <p>Lg=1854mm</p> <p>J635</p> | <p>BD X1</p>  <p>5905</p>           | <p>BE X2</p>  <p>PPL920</p>           |
| <p>BF X1</p>  <p>PPL918</p>               | <p>BG X1</p>  <p>PPL919</p>         | <p>BH X5</p>  <p>CAP20</p>            |

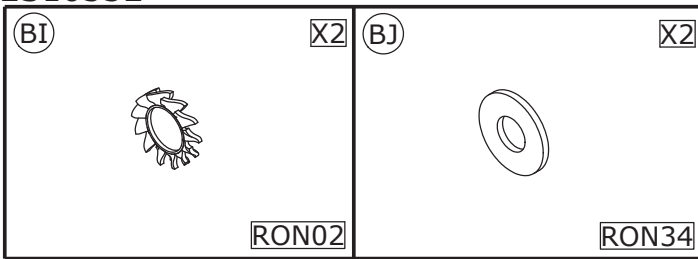

MATERIEL NÉCESSAIRE  
MATERIALE NECESARIO  
NODIGE GEREEDSCHAP  
MATERIAL NECESARIO  
BENODIGTE WERKZEUGE

Colle polyuréthane  
Colla poliuretano  
Lijm polyurethaan  
Pegamento poliuretano  
Polyurethan-Klebstoff

Non acétique  
Non acetico  
Zonder azijnzuur  
No acética  
Nicht essigsauer

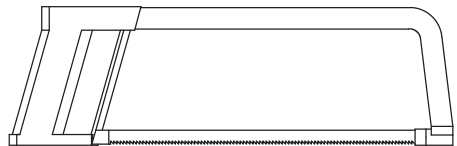
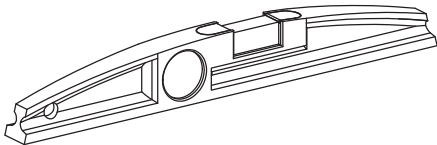
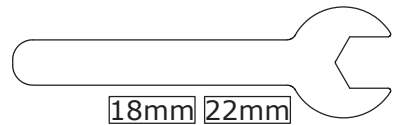
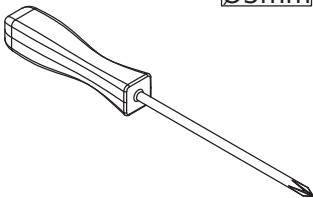
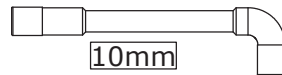
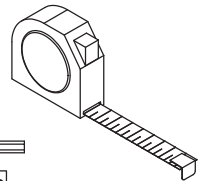
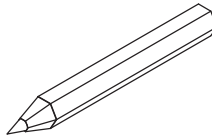
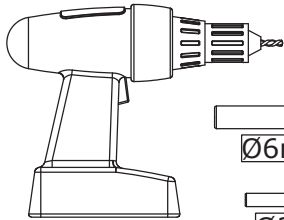
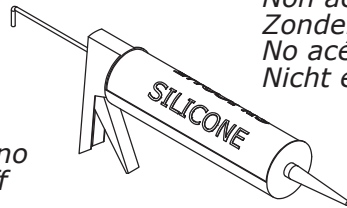
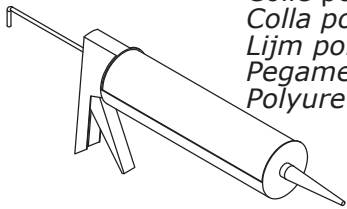



REVERSIBILITE/REVERSIBILITA/OMKEERBAARHEID/REVERSIBILITA/WAHLWEISE MONTAGE

MONTAGE A GAUCHE  
MONTAGGIO A SINISTRA  
MONTAGE LINKS  
MONTAJE A LA IZQUIERDA  
MONTAGE LINKS

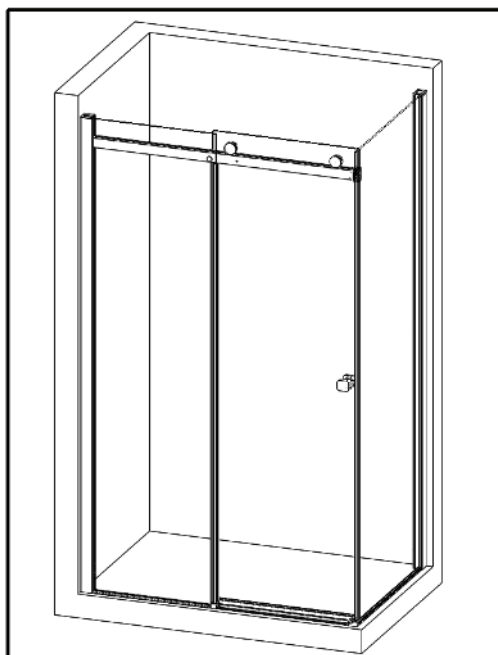

MONTAGE A DROITE  
MONTAGGIO A DESTRA  
MONTAGE RECHTS  
MONTAJE A LA DERECHA  
MONTAGE RECHTS

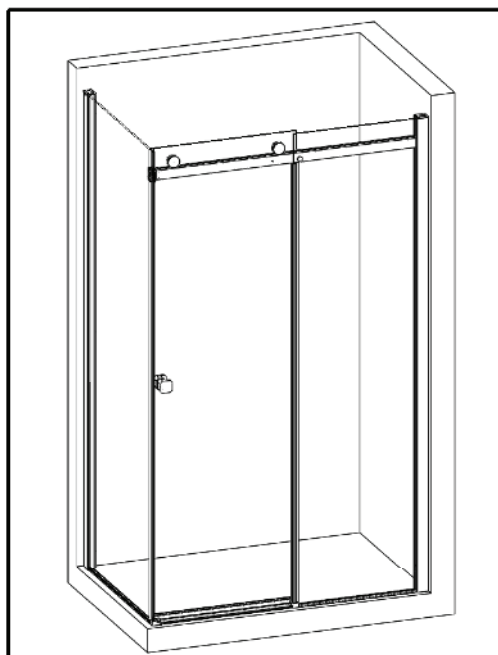

Vous avez la possibilité de réaliser un montage à droite ou un montage à gauche. Notre notice d'installation décrit un montage à gauche. si vous voulez réaliser un montage à droite, il vous suffit d'inverser le montage.

*Avete la possibilità di effettuare il montaggio a destra o a sinistra. Il nostro manuale descrive il montaggio a sinistra. Se volete realizzare il montaggio a destra è sufficiente invertire varie fasi di montaggio.*

*U kunt de cabine rechts of links monteren. Onze handleiding beschrijft de linkse montage van de cabine. Keer de montage om als u de cabine rechts wilt monteren.*

*Puede realizar un montaje a la derecha o un montaje a la izquierda. Nuestro folleto de instalación describe un montaje a la izquierda. Si desea montar su cabina a la derecha sólo tendrá que realizar el montaje al contrario.*

*Sie haben die Möglichkeit, eine Montage auf der linken Seite oder eine Montage auf der rechten Seite durchzuführen. Unsere Montageanleitung beschreibt eine Montage auf der linken Seite. Wenn Sie die Montage lieber auf der rechten Seite durchführen wollen, müssen Sie nur den Montageprozess umkehren.*



**Remarque importante**  
**Nota importante**  
**Belangrijke opmerking**  
**Nota importante**  
**Wichtiger Hinweis**



**Avant de commencer le montage, fermer l'eau.**  
**Prima di iniziare il montaggio chiudere l'acqua.**  
**Sluit de watertoevoer af voordat u begint met de installatie.**  
**Antes de empezar el montaje cierre el agua.**  
**Stellen Sie das Wasser ab, bevor Sie mit der Installation beginnen**

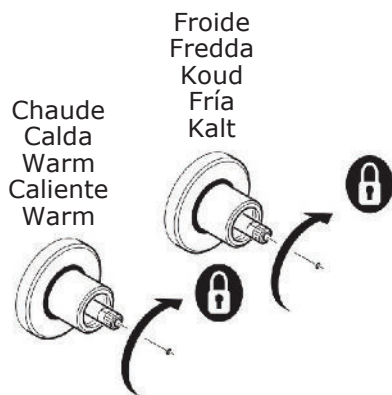
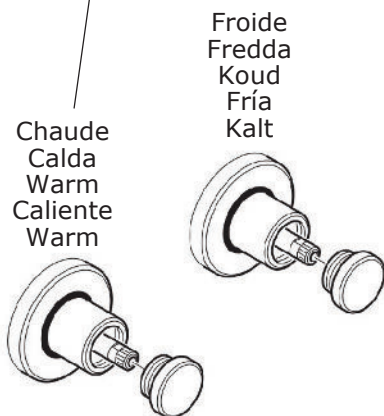
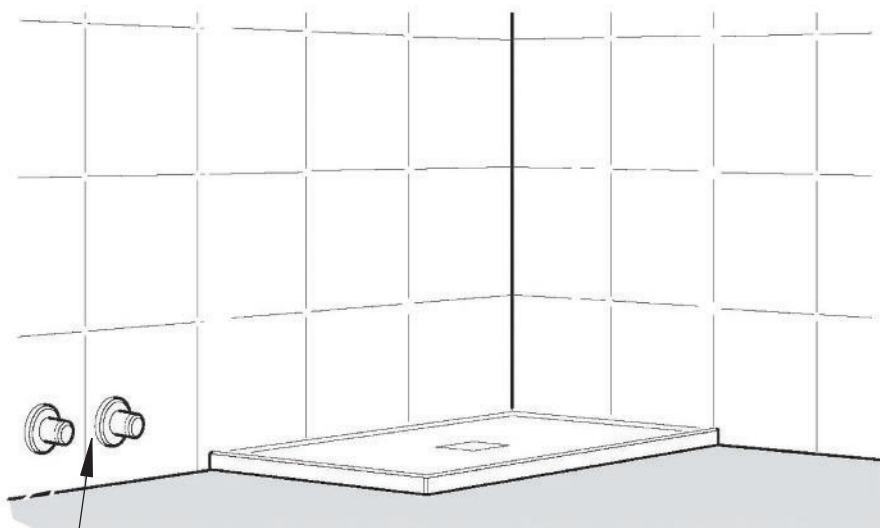



**Remarque importante  
Nota importante  
Belangrijke opmerking  
Nota importante  
Wichtiger Hinweis**



**Vérifier que le receveur soit installé correctement  
(Voir les instructions de montage receveur)  
Le paroi de douche ne permet pas de rattrapage de niveau**

**Vérificare che il piatto sia installato correttamente  
(Vedere istruzioni montaggio piatto)  
Le pareti della cabina non consentono la regolazione di  
eventuali dislivelli del piatto doccia**

**Zorg ervoor dat de douchebak correct is geïnstalleerd  
(Zie instructies voor montage douchebak)  
De wanden van de cabine staan geen aanpassing van de  
oneffenheden in de douche toe**

**Comprobar que el plato está instalado correctamente  
(Véanse las instrucciones del montaje del plato)  
Las paredes de la cabina no permiten la regulación de las  
irregularidades en la ducha**

**Prüfen Sie, ob die Duschwanne korrekt montiert ist  
(Siehe Installationsanleitungen Duschwanne)  
Die Duschwand erlaubt es nicht, Höhenunterschiede auszugleichen**

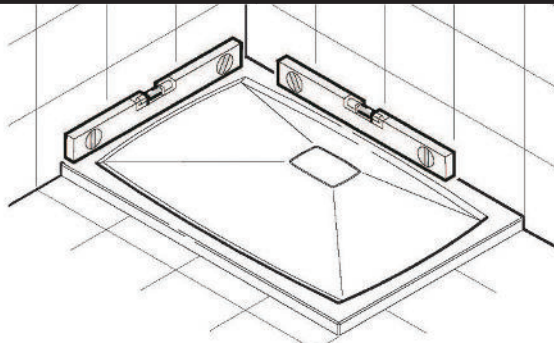

Protéger le receveur avec du carton ou du fil à bulles

Proteggere il piatto con cartone o pluriball

Scherm de douchebak af met karton of noppenfolie

Proteger el plato con cartón o film alveolar

Schützen Sie die Duschwanne mit Pappe oder Luftpolsterfolie

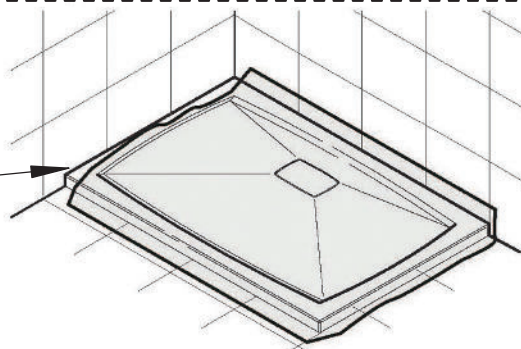

01

X6

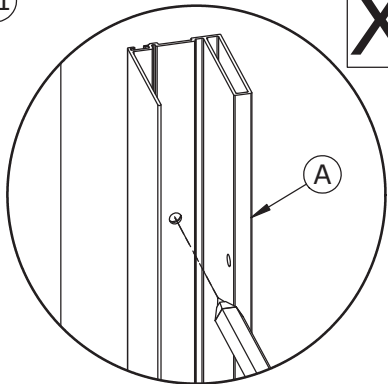

Extérieur  
 Esterno  
 Buitenzijde  
 Externo  
 Außen

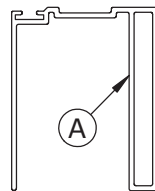

Intérieur  
 Interno  
 Binnenzijde  
 Interno  
 Innen

Extérieur  
 Esterno  
 Buitenzijde  
 Externo  
 Außen

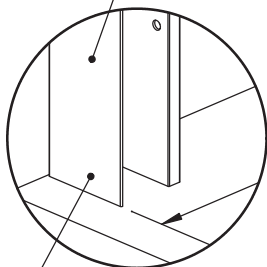

A

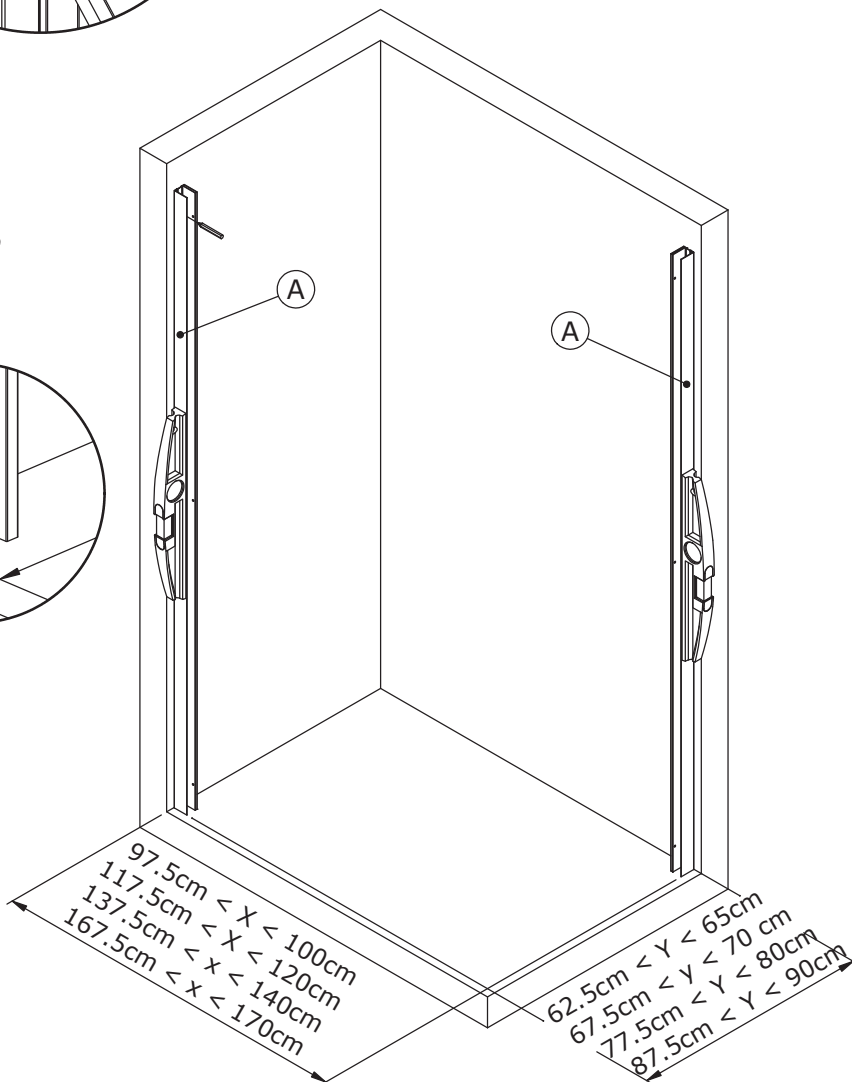

02

X2

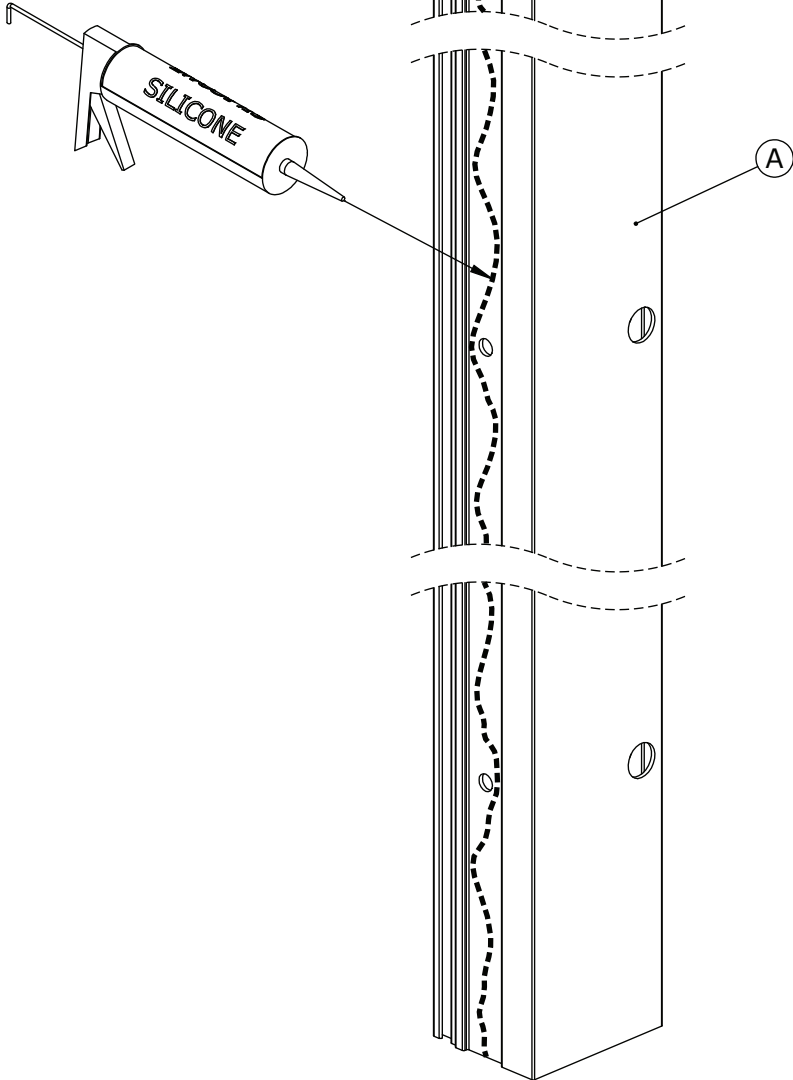

03

X6

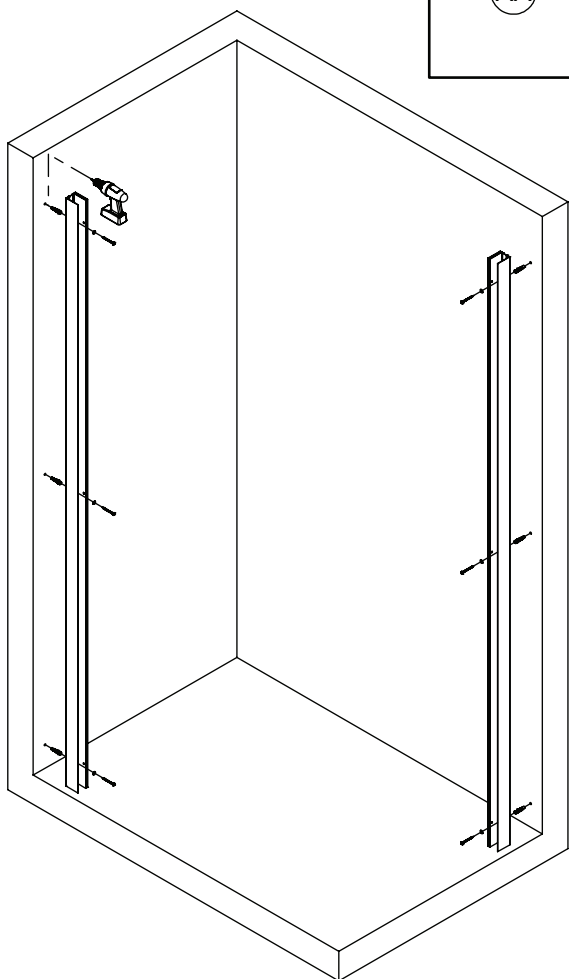
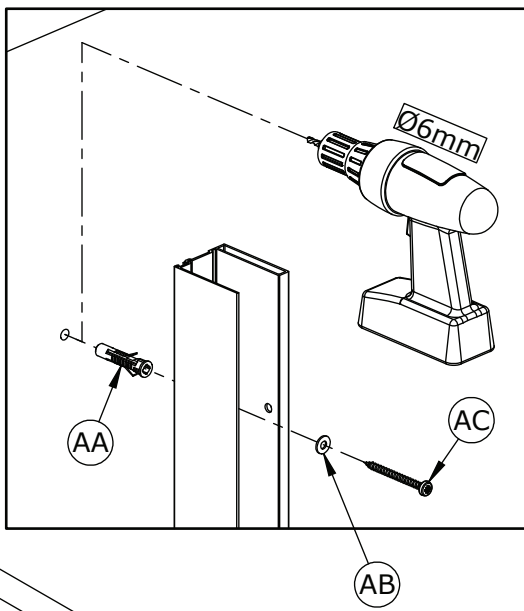

04

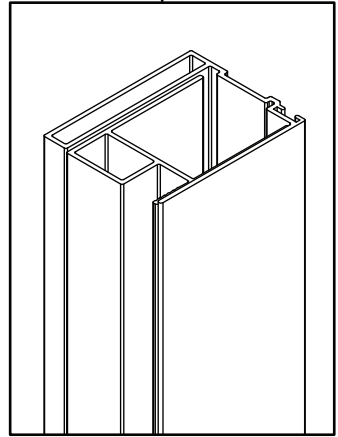
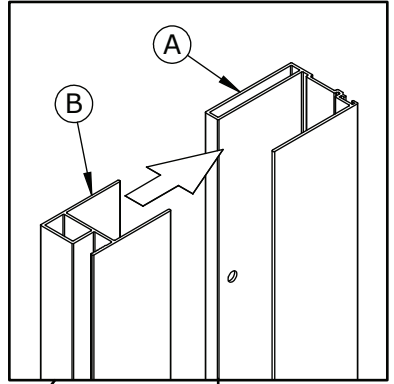
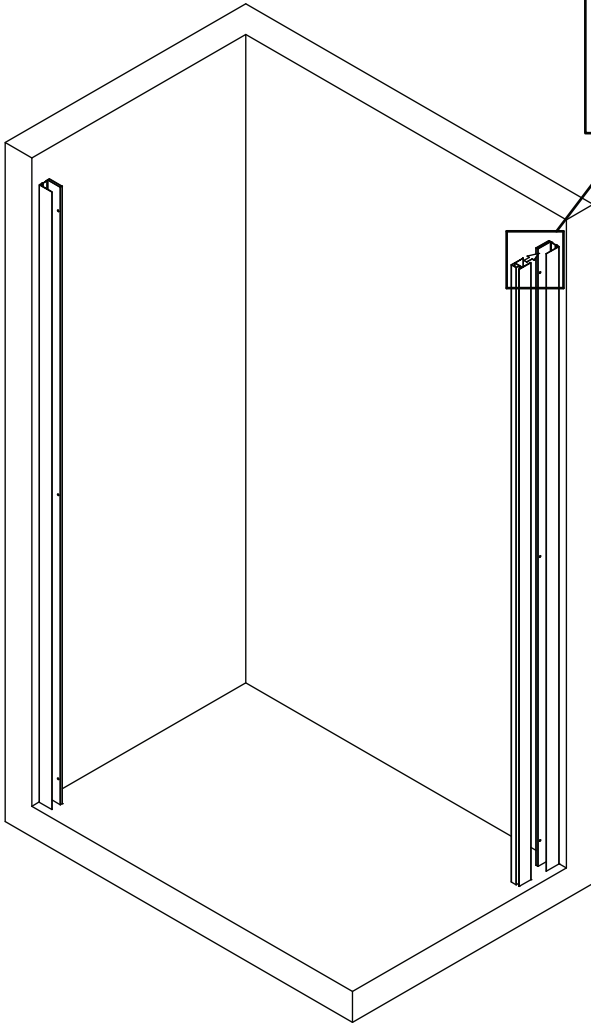

05

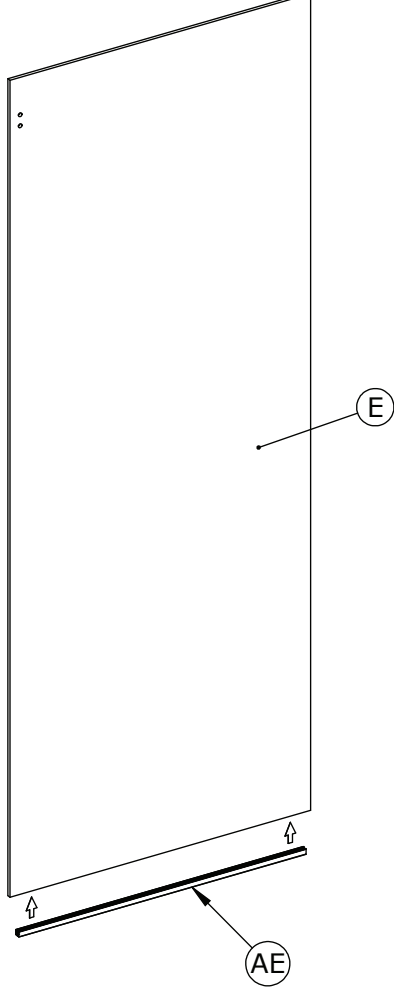
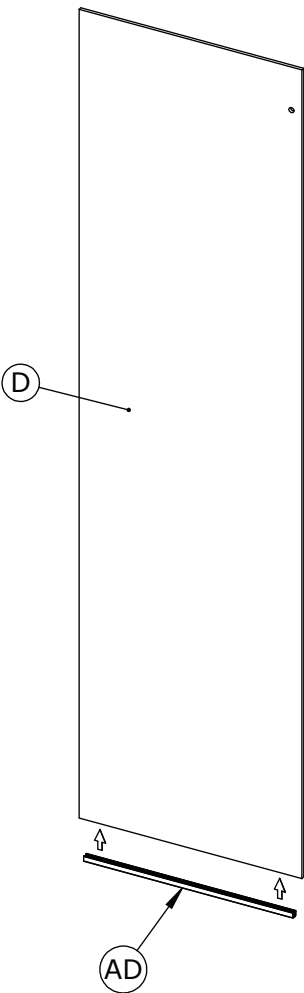
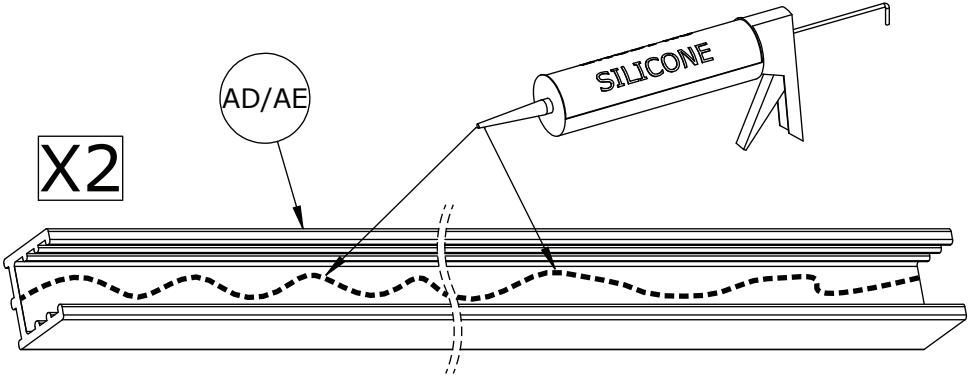



06

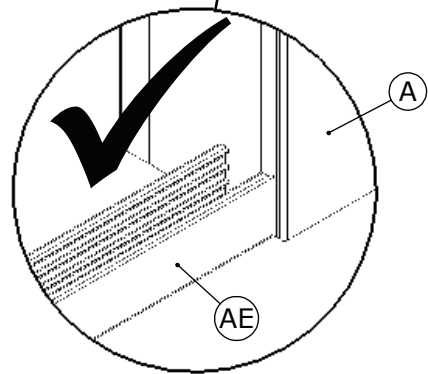
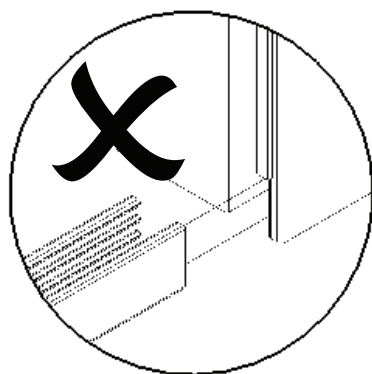
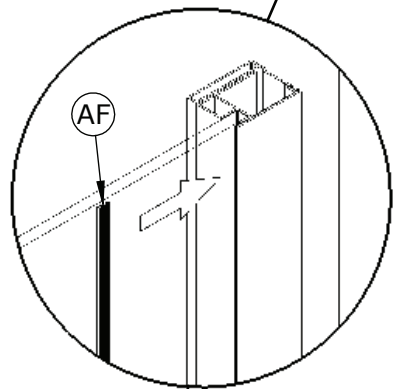
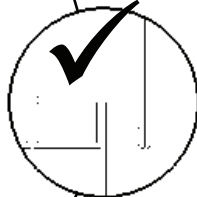
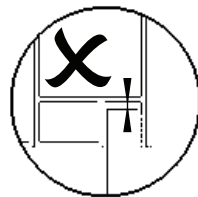
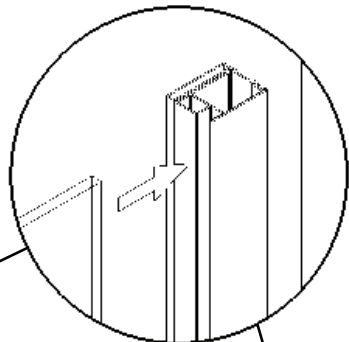
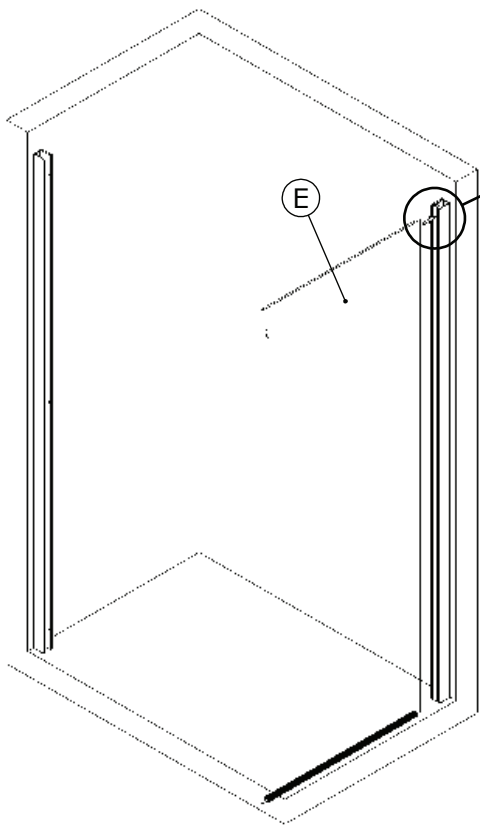

07

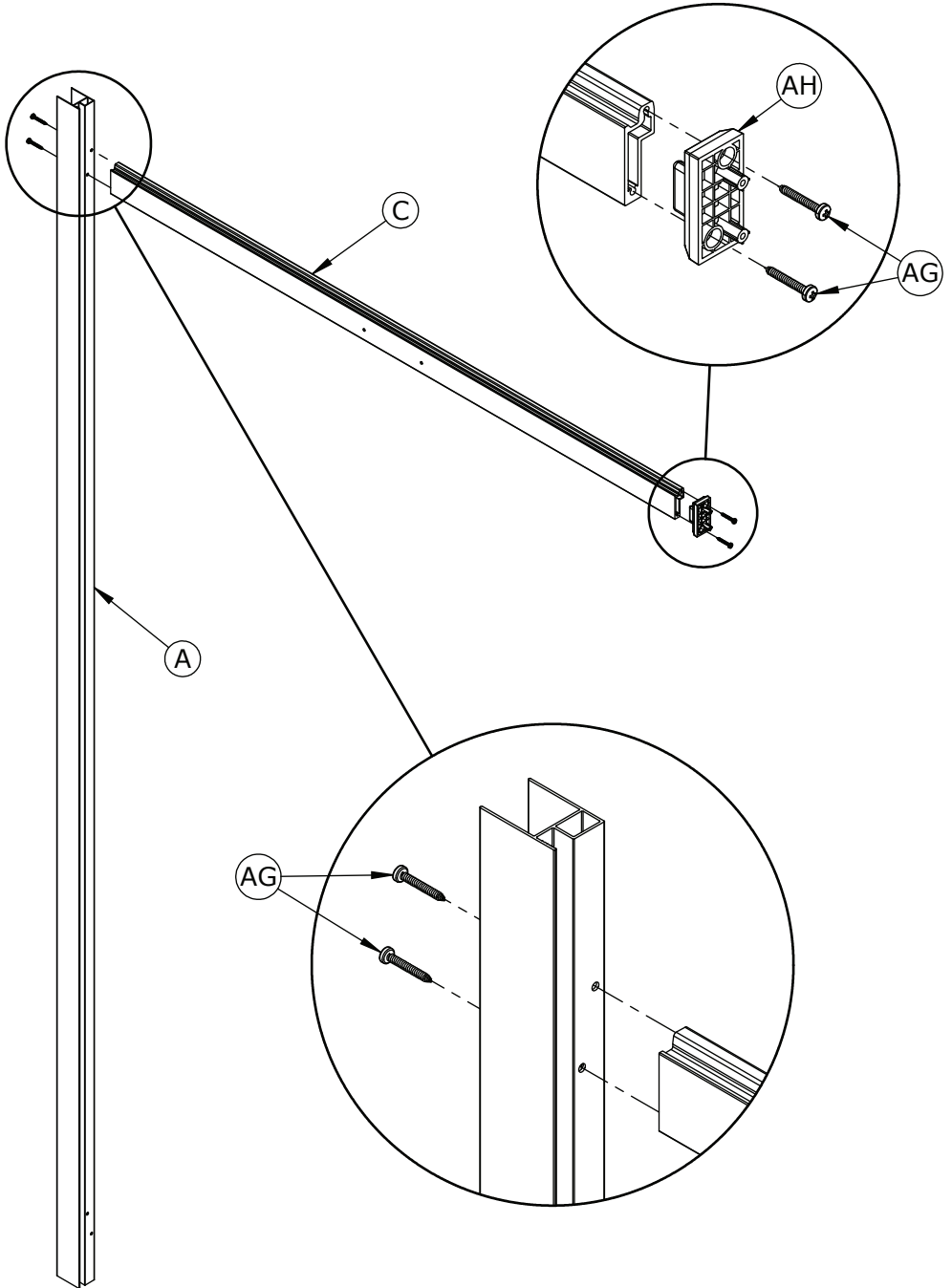

08

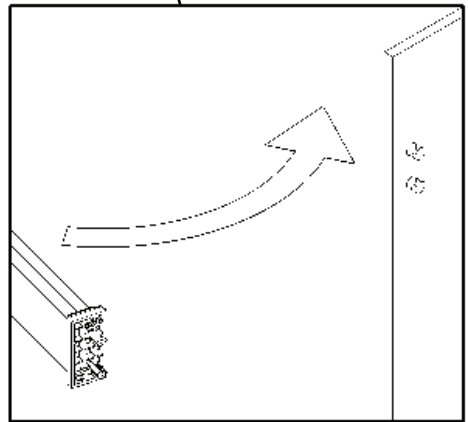
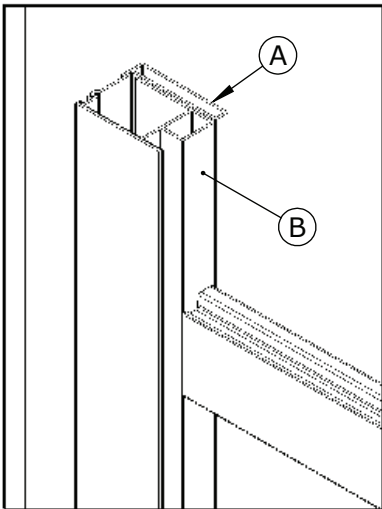
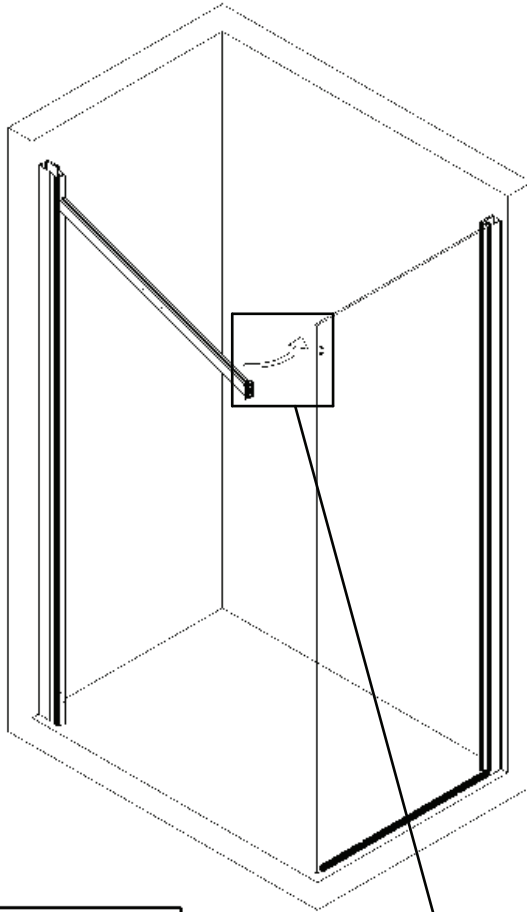

09

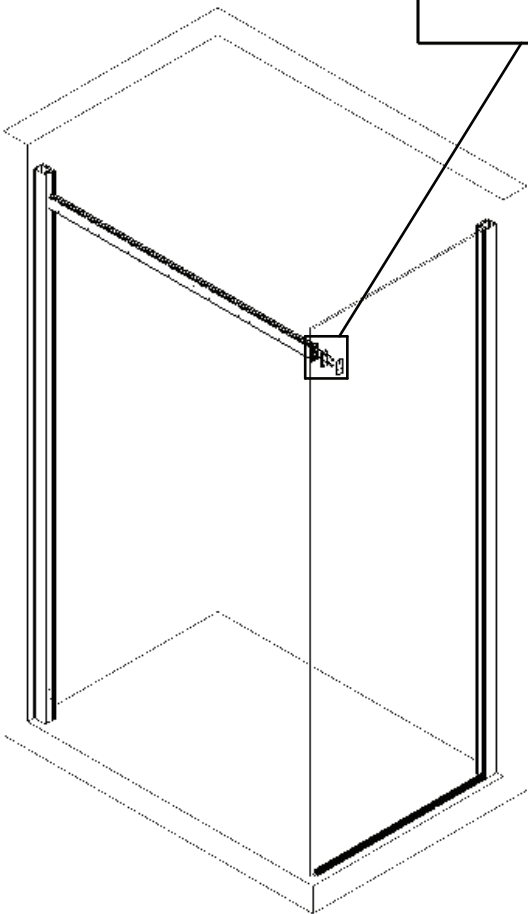
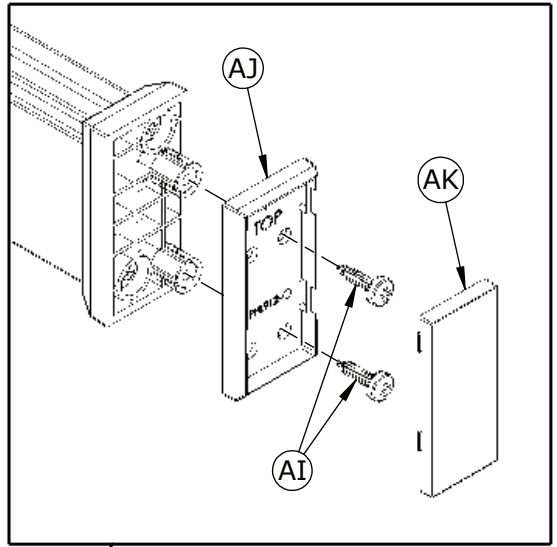

10

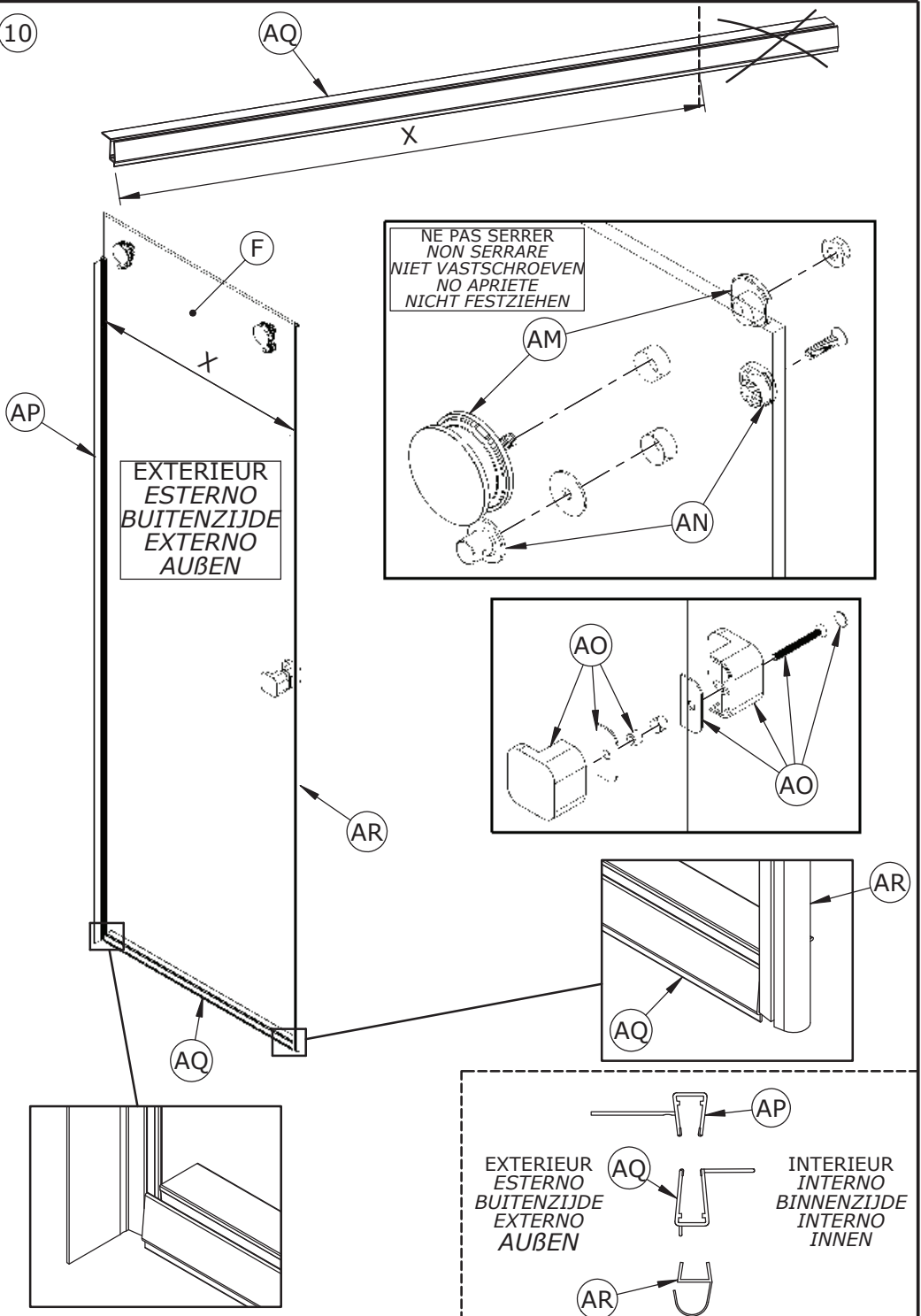

11

Ne pas serrer fort  
 Non stringere forte  
 Niet vastschroeven  
 No apriete  
 Nicht festziehen

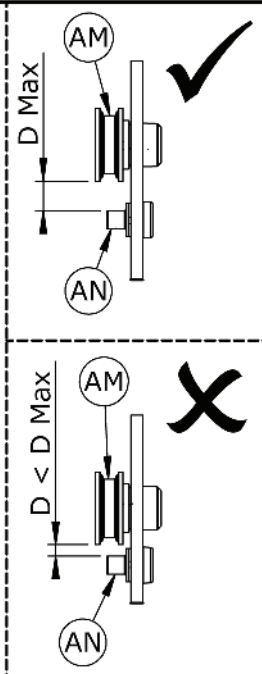
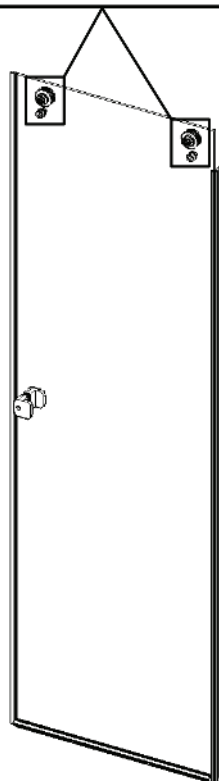
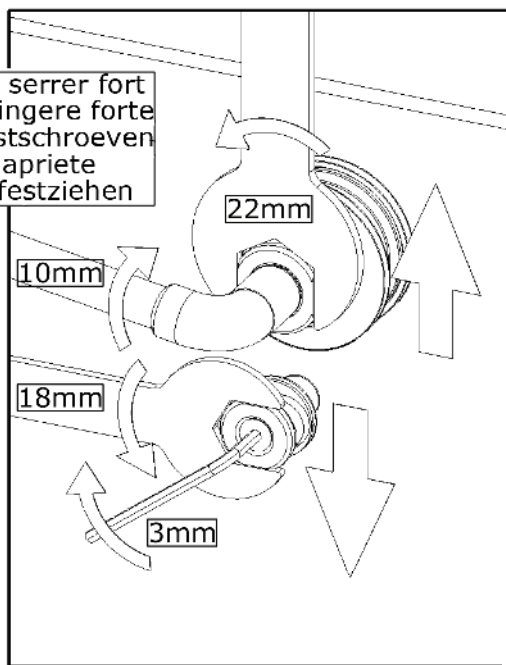

12

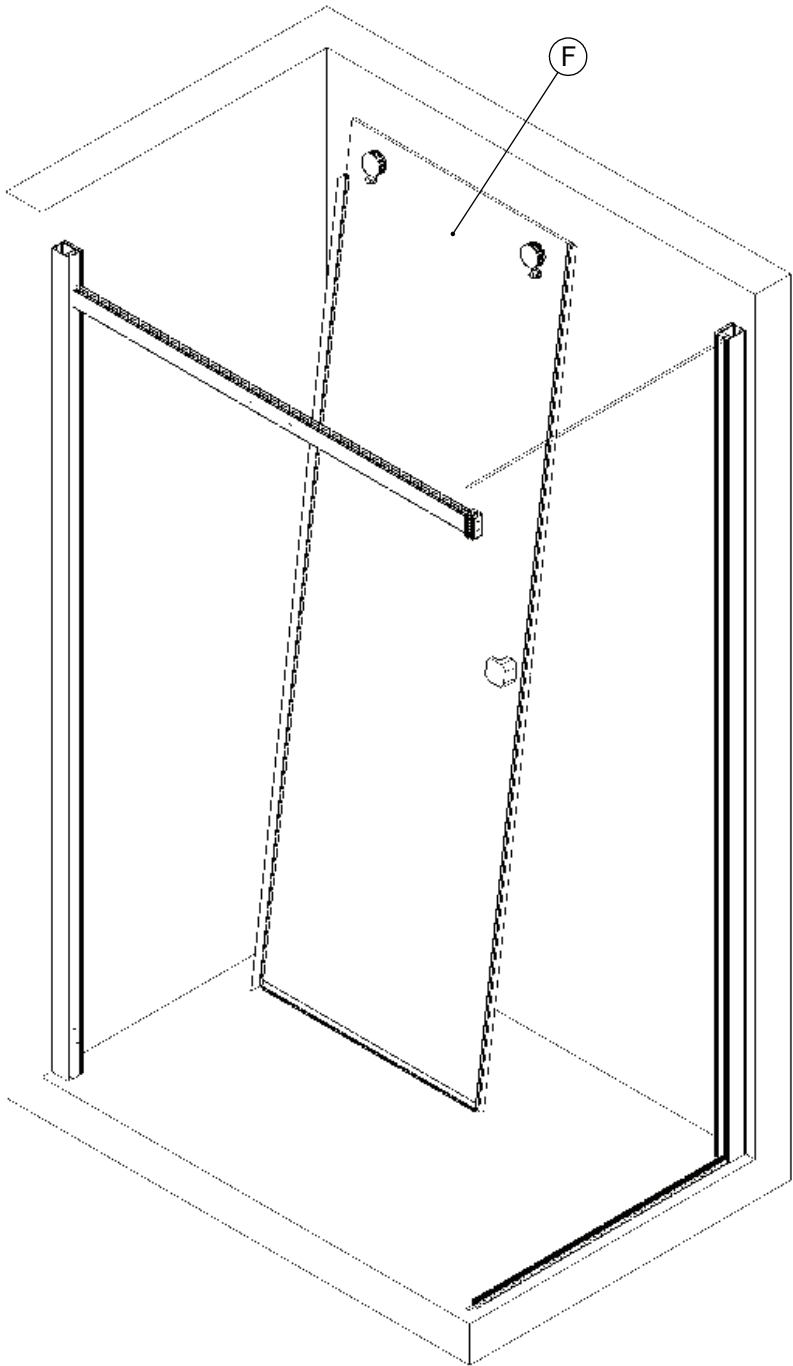

13

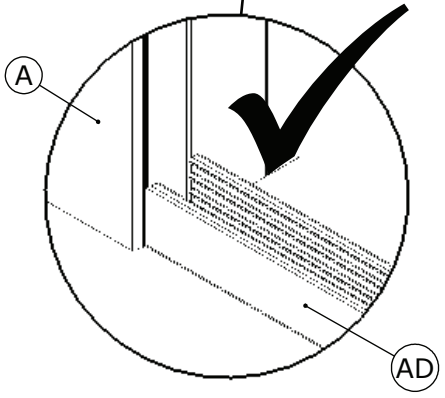
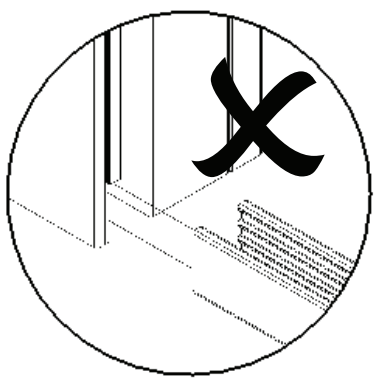
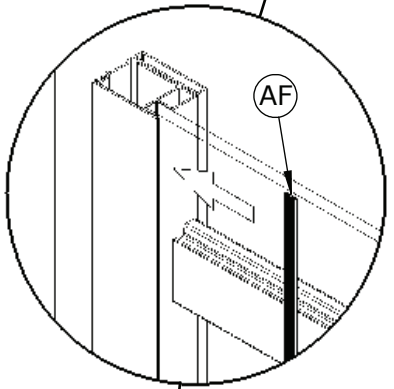
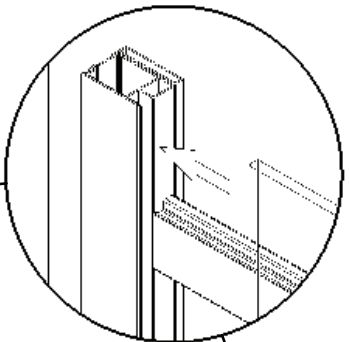
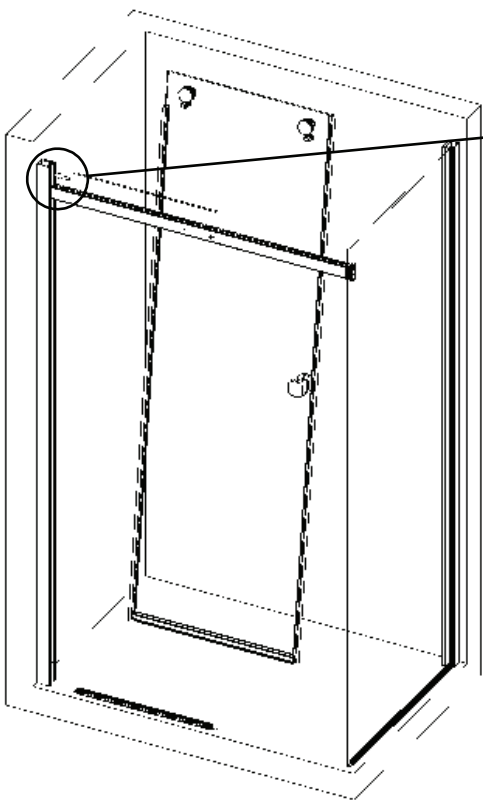



14

Pré-réglage avec excentrique  
Regolazione primaria con eccentrico  
Erste abstellung mit excentriek  
Ajustar el tornillo excéntrico sin apretar  
Exzentrerschraube ohne Anziehen einstellen

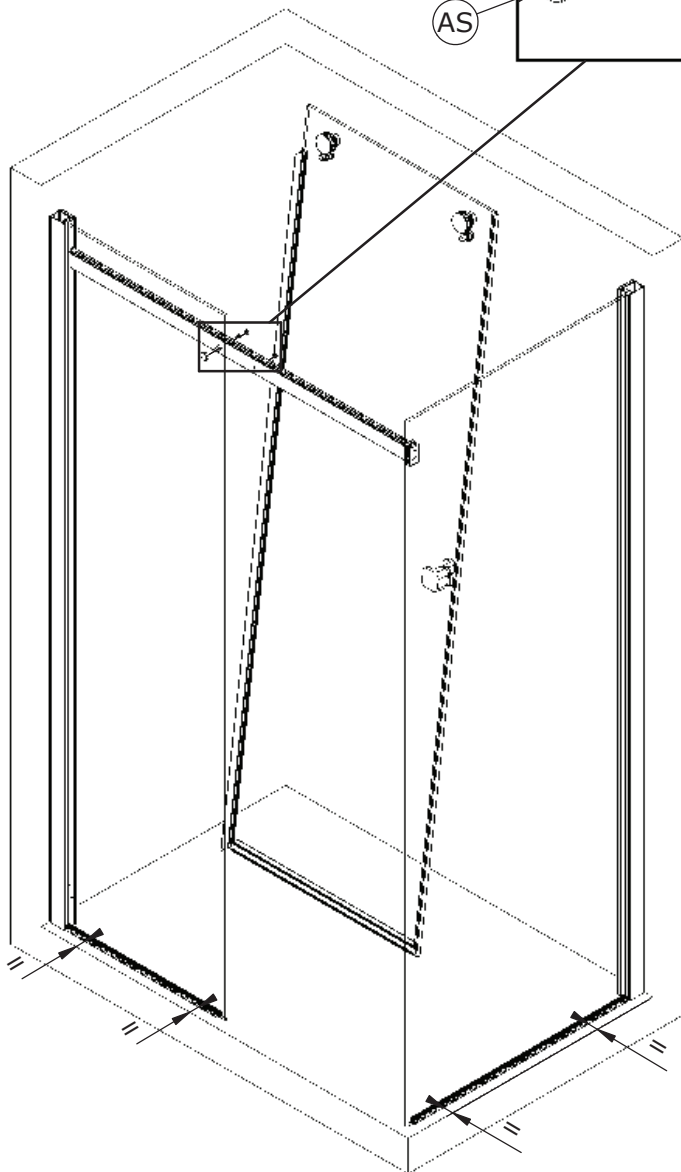
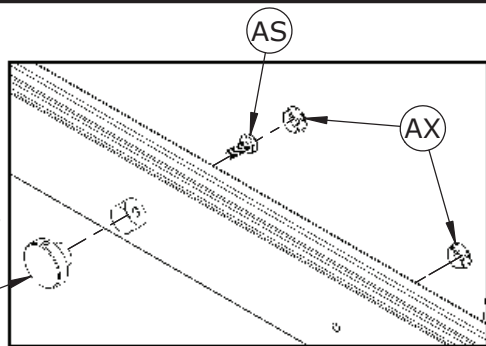

Montage avec receveur  
Montaggio con piatto  
Assembleren met douchebak  
Montaje con plato  
Montage mit Empfänger

15

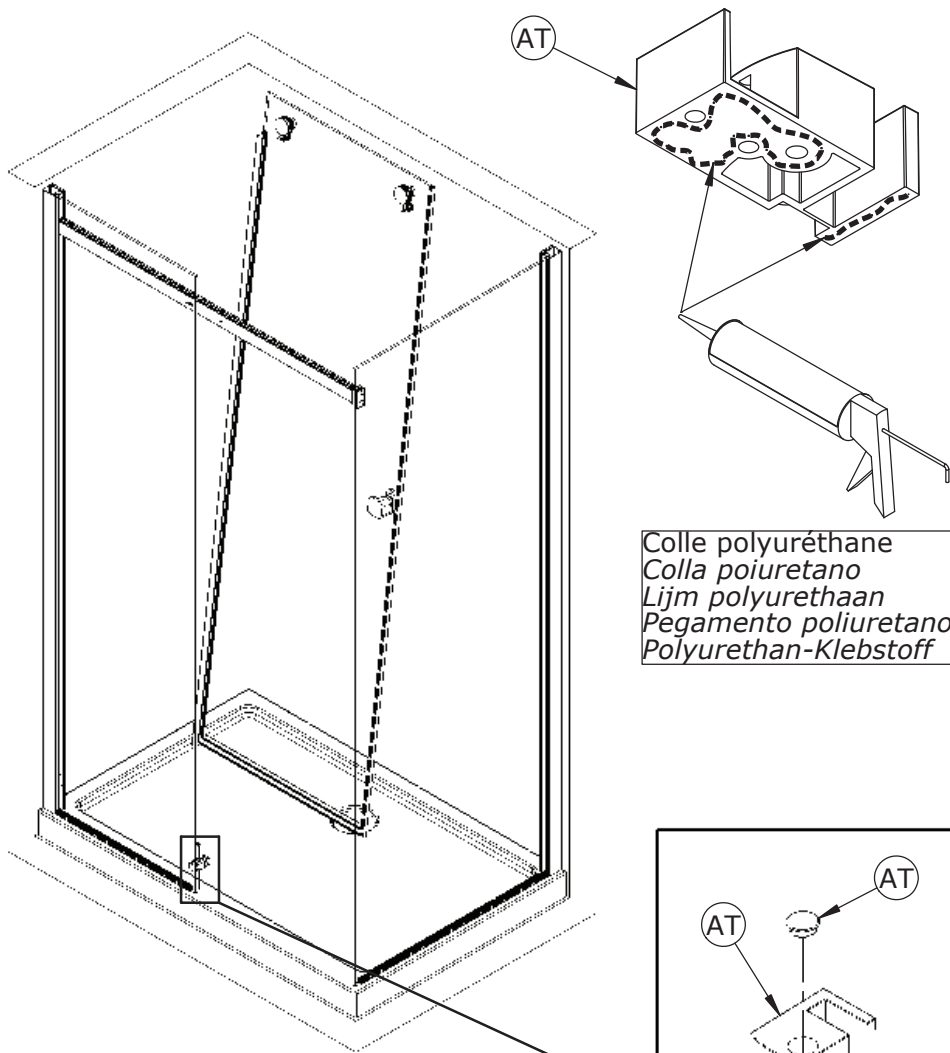

Colle polyuréthane  
 Colla poliuretano  
 Lijm polyurethaan  
 Pegamento poliuretano  
 Polyurethan-Klebstoff

Intérieur  
 Interno  
 Binnenzijde  
 Interno  
 Innen

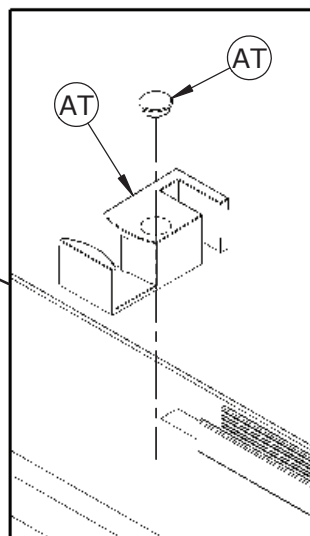

16

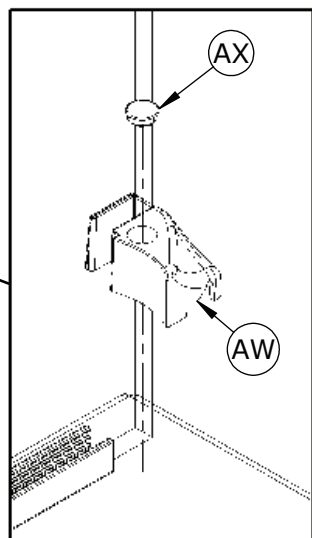
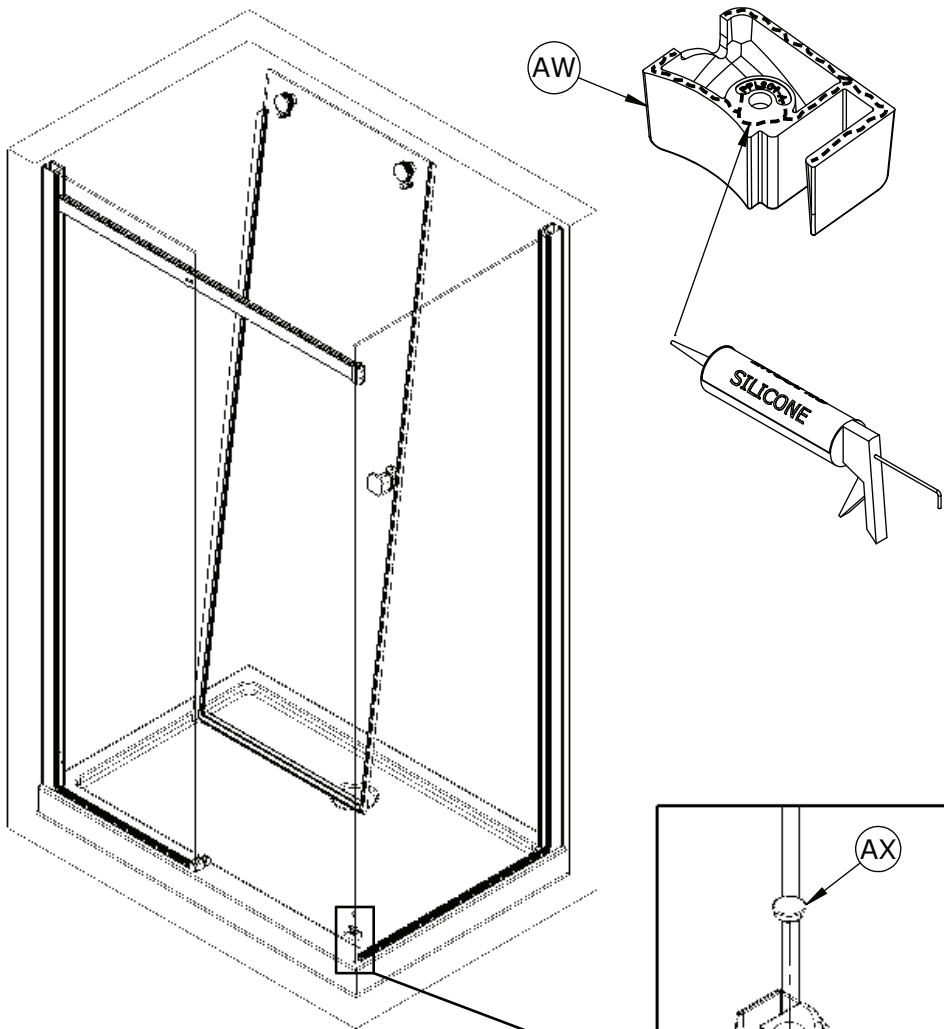

Montage sans receveur  
Montaggio senza piatto  
Assembleren zonder douchebak  
Montaje sin plato  
Montage ohne Duschwanne

15b

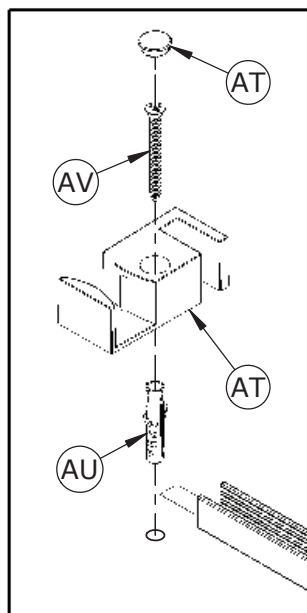
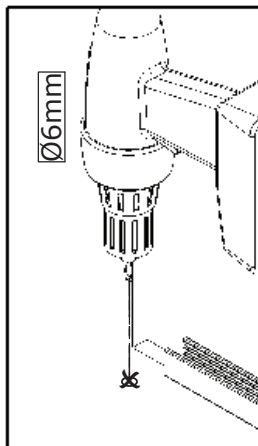
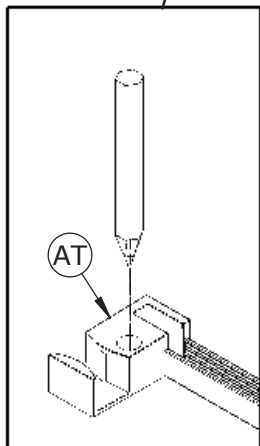
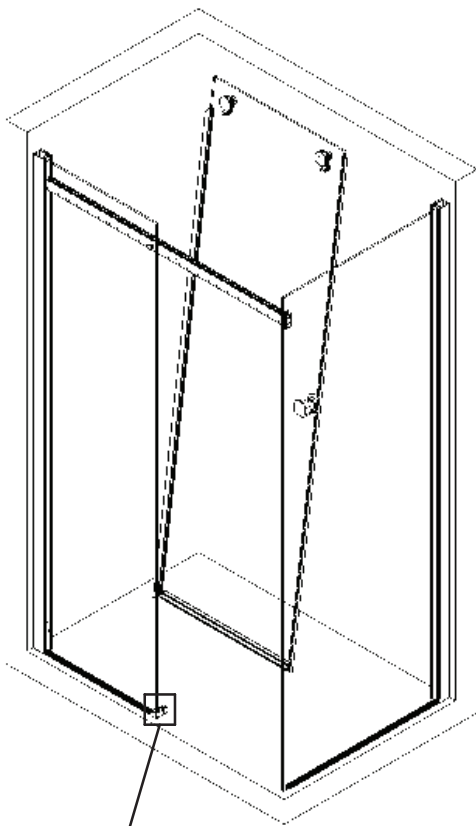

INTERIEUR - INTERNO - BINNENZIJDE - INTERNO - INNEN

16b

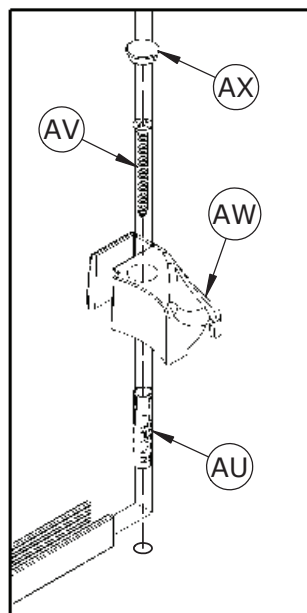
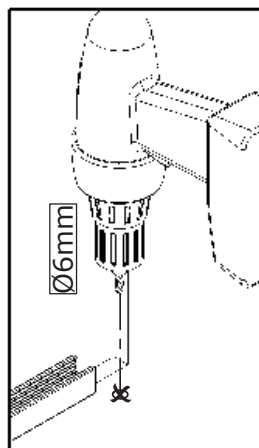
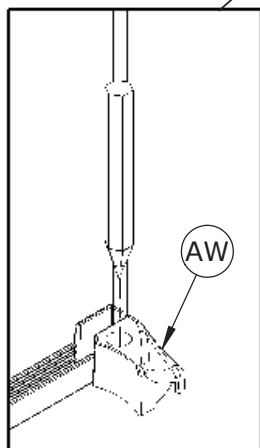
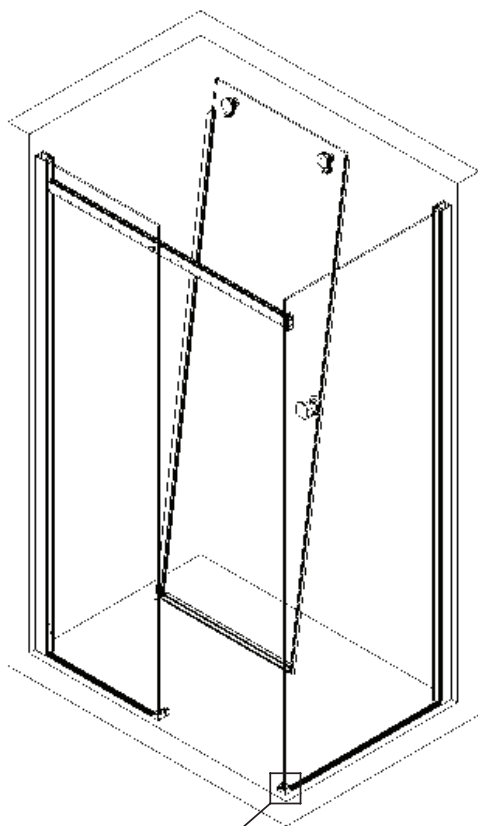

INTERIEUR - INTERNO - BINNENZIJDE - INTERNO - INNEN



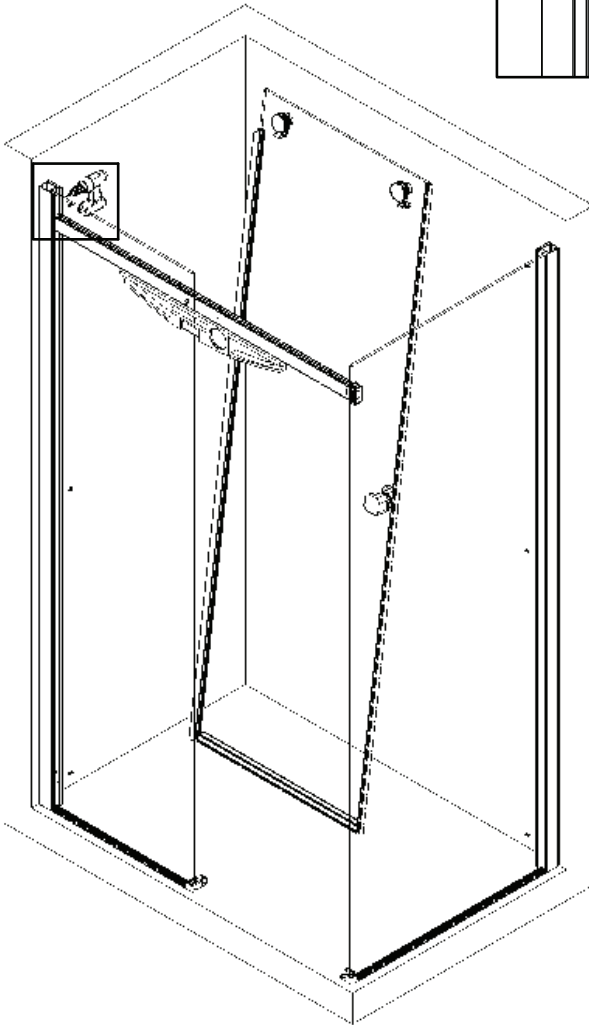
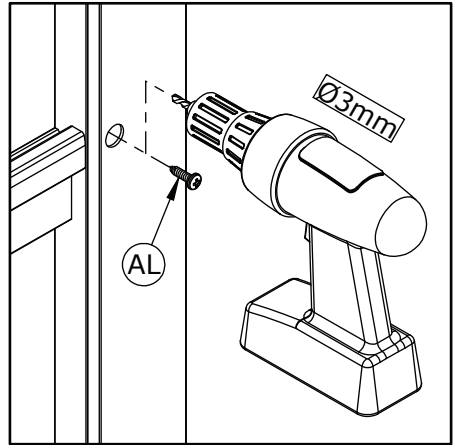

17

**X6**

18

2

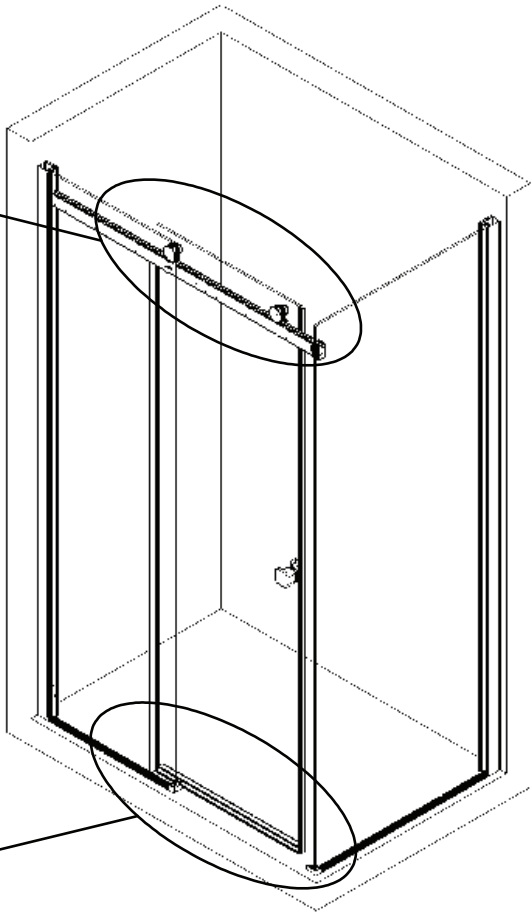
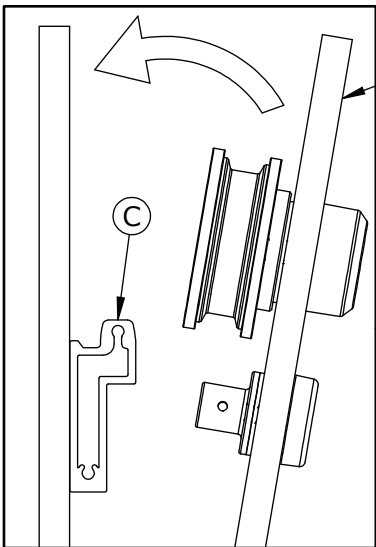

1

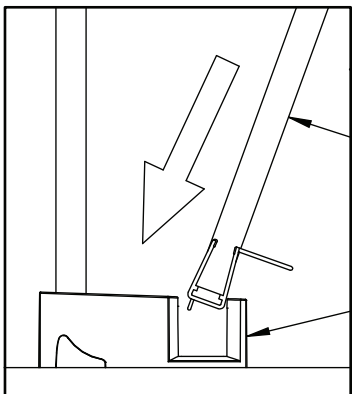

19

Régler la porte  
 Regolare le porte  
 Stel de deuren  
 Ajustar la puerta  
 Tür einstellen

1

Serrer  
 Serrare  
 Andraaien  
 Apretar  
 Festziehen

2

Serrer  
 Serrare  
 Andraaien  
 Apretar  
 Festziehen

3

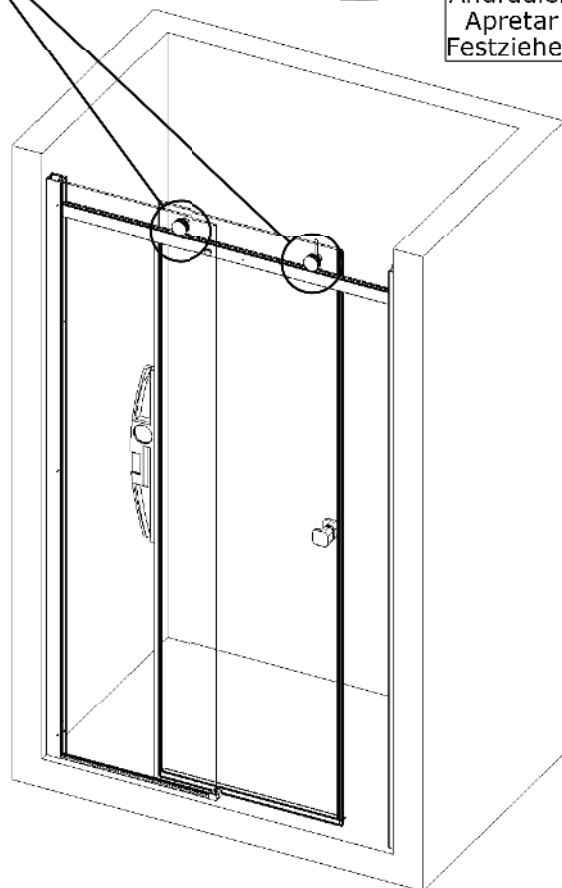

AK

AL



MIN 0,5mm  
 MAX 2mm

E

20

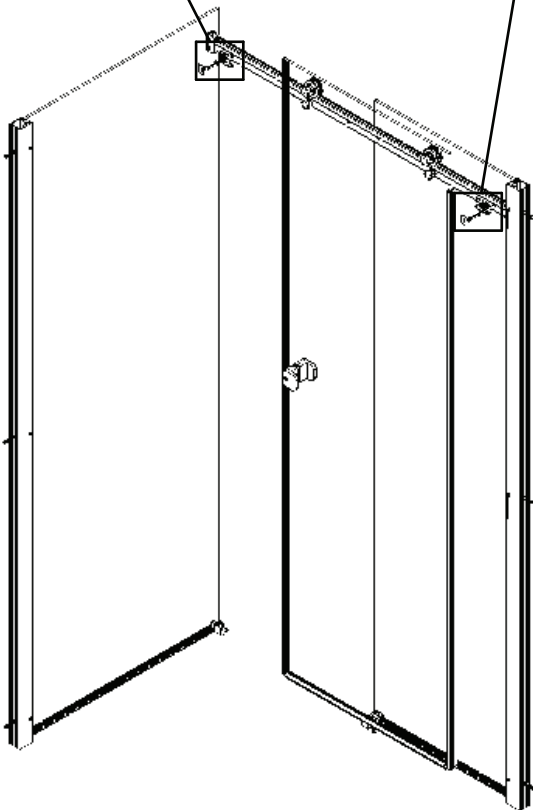
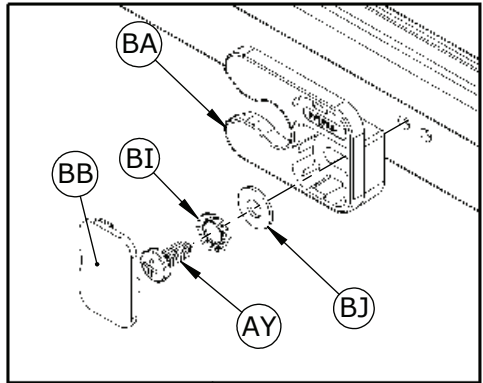
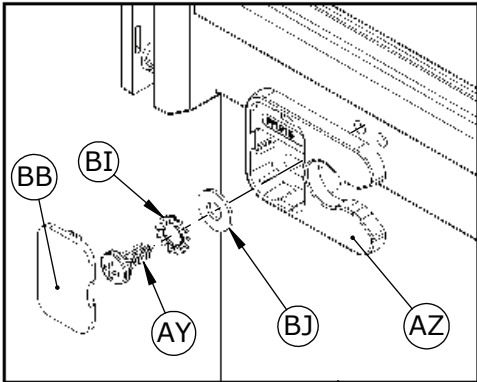

21

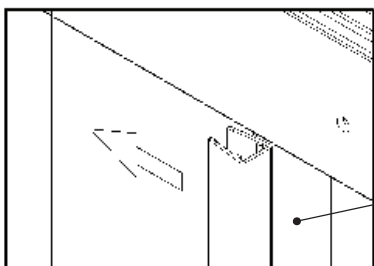

BC

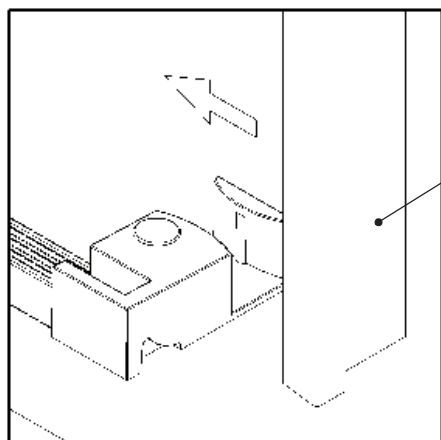
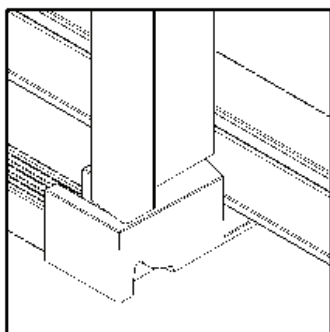
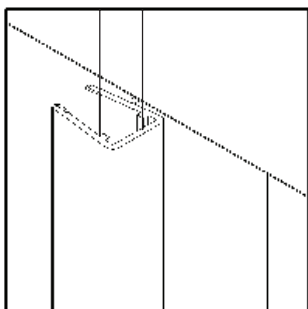

BC

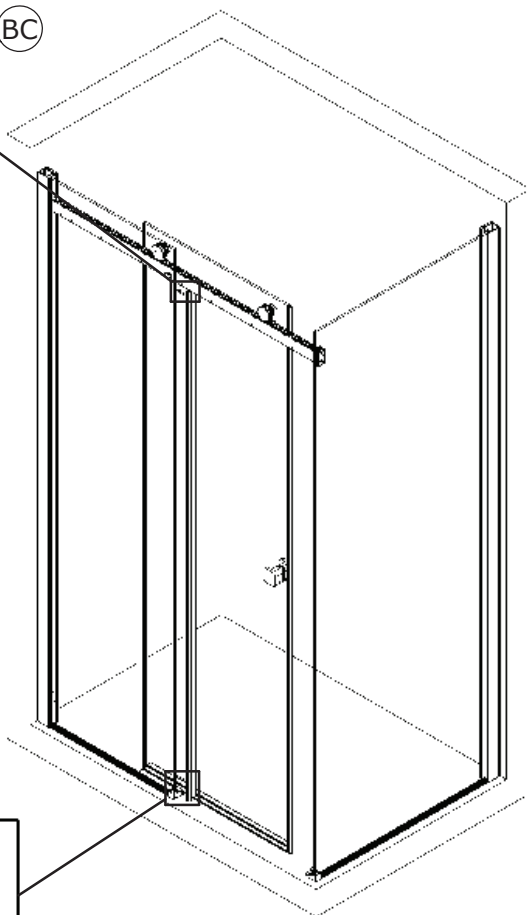

EXTERIEUR  
ESTERNO  
BUITENZIJDE  
EXTERNO  
AUBEN

INTERIEUR  
INTERNO  
BINNENZIJDE  
INTERNO  
INNEN



BC

22

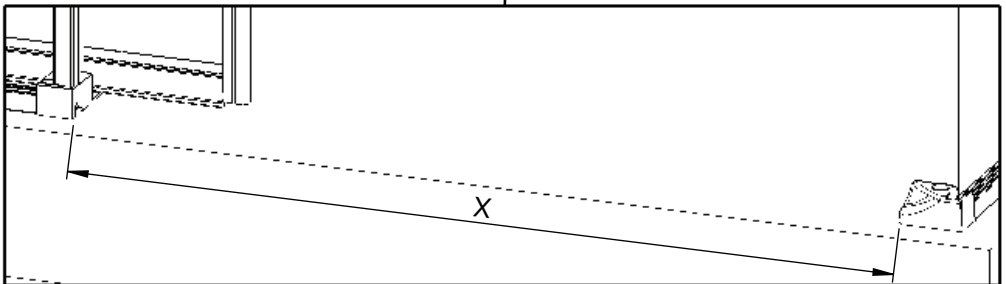
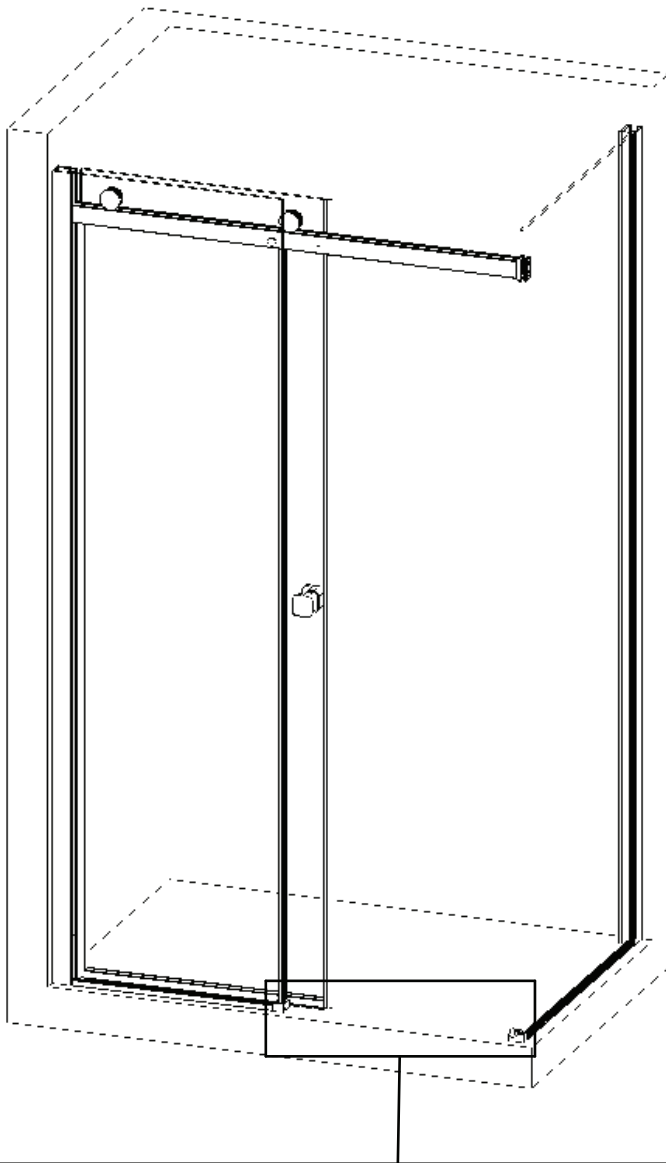

23

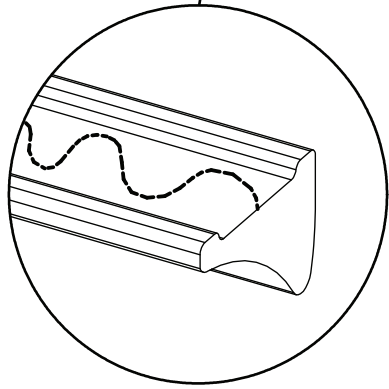
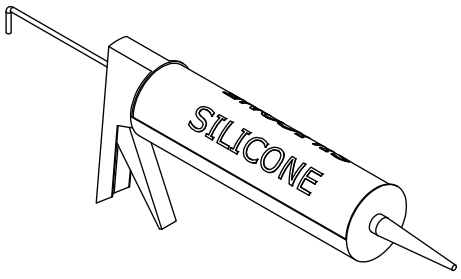
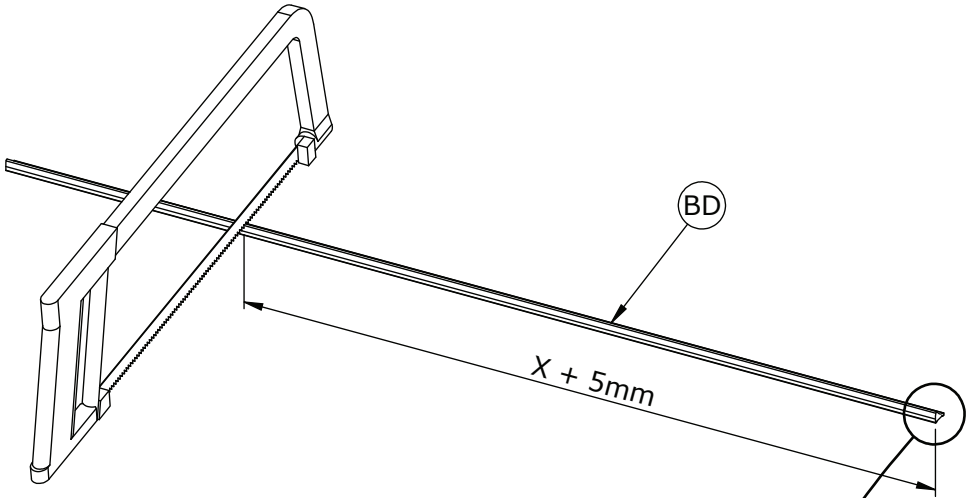

(24)

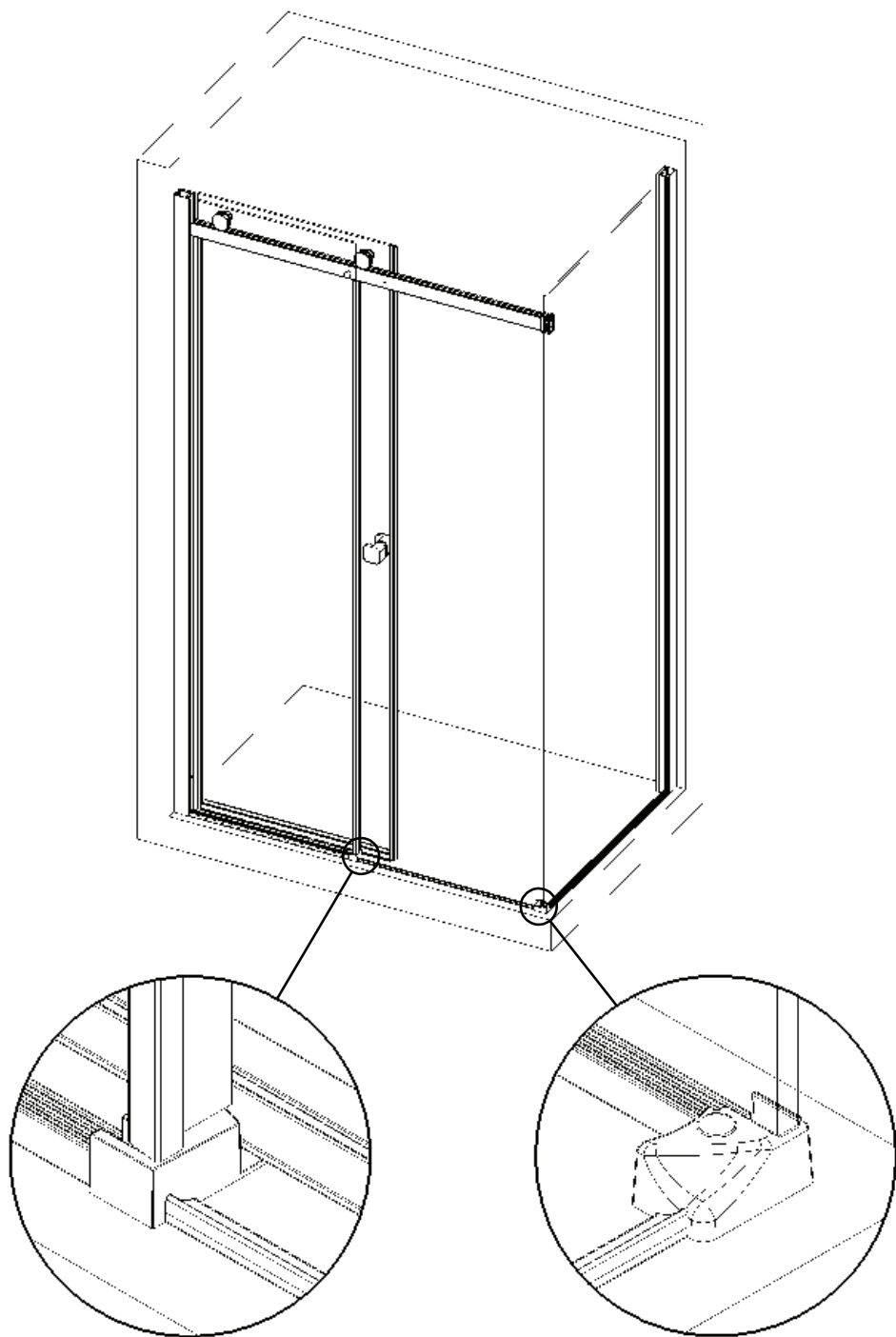



25

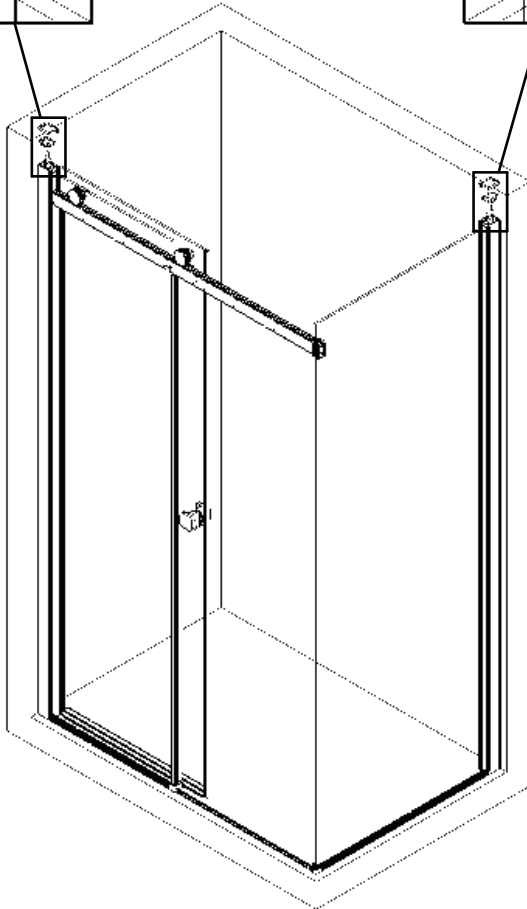
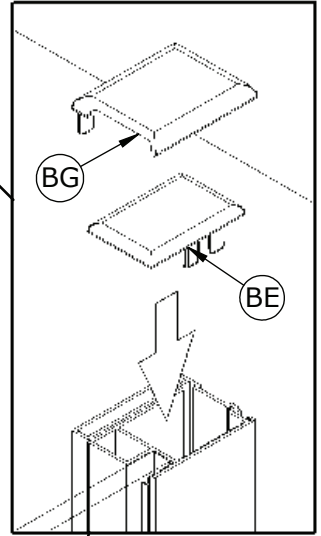
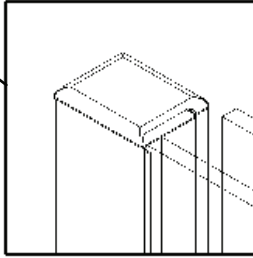
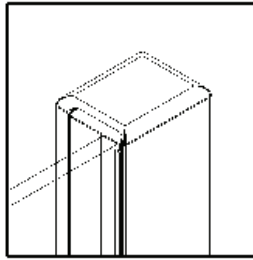
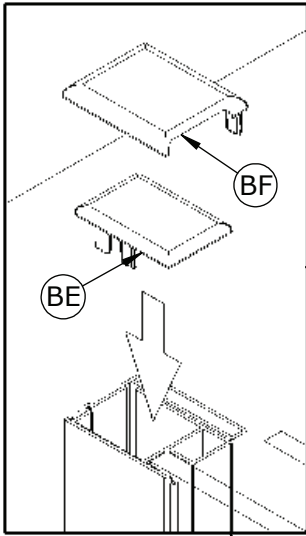

26

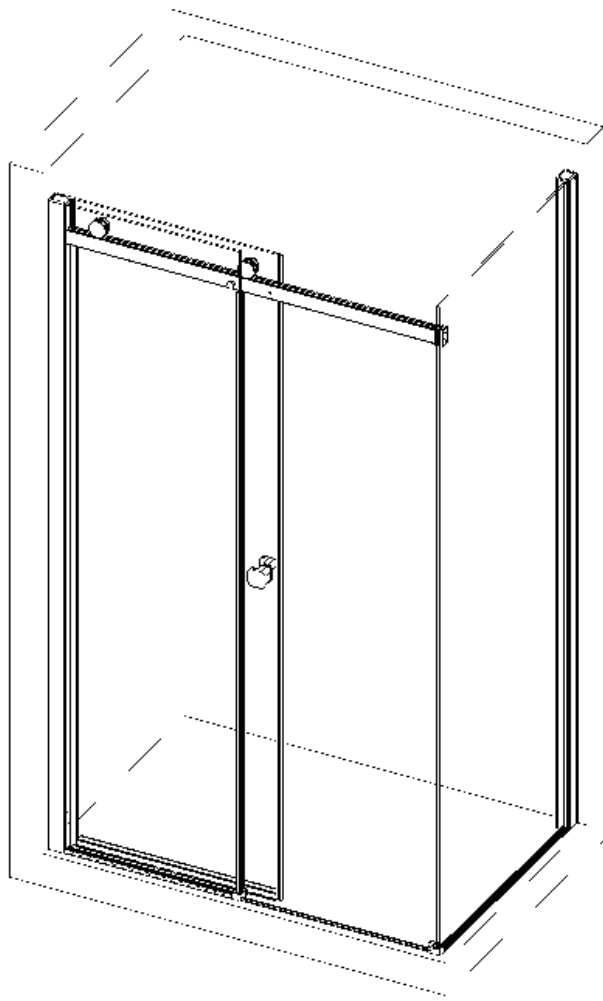

X5

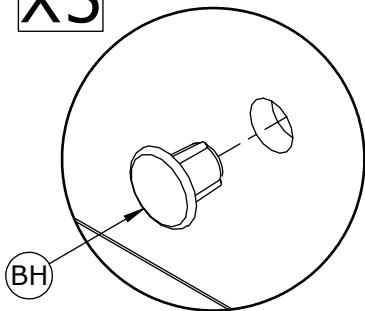

X6

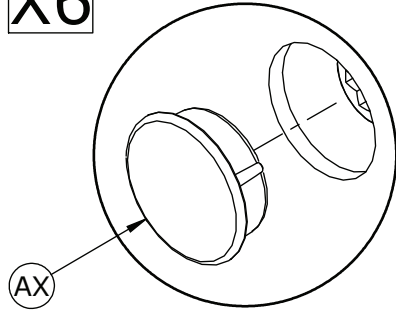

27

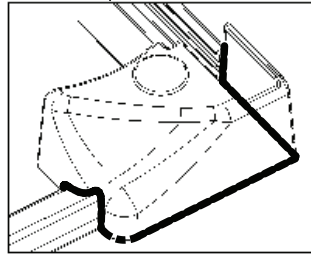
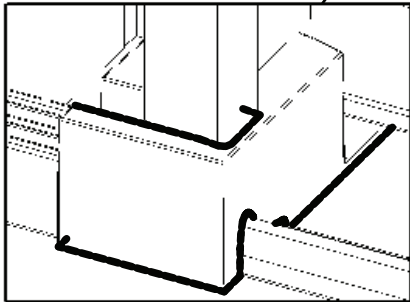
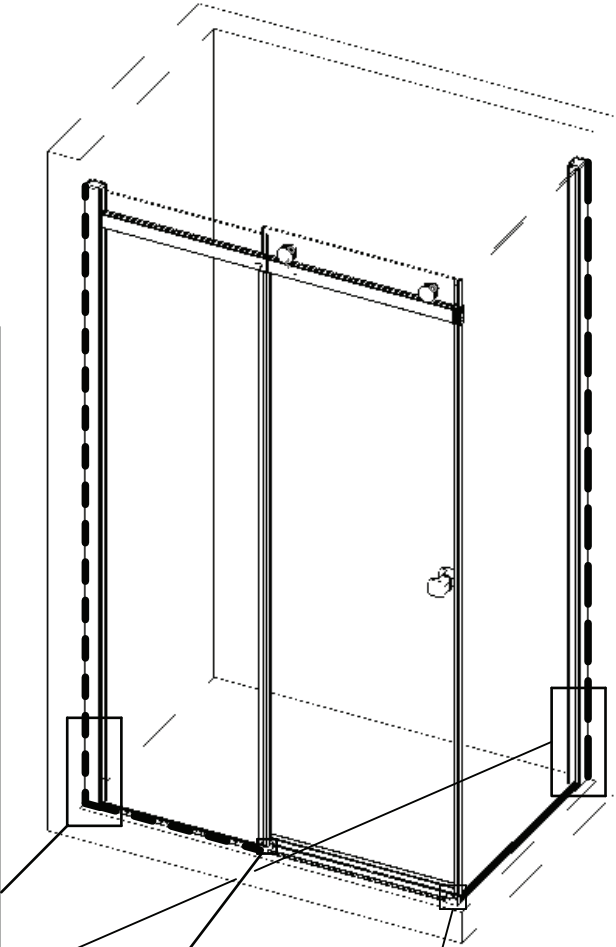
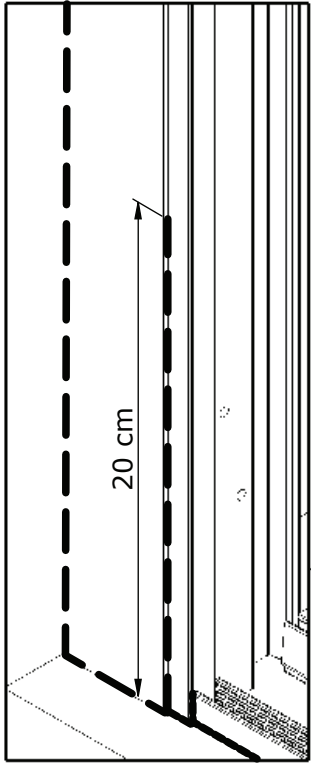
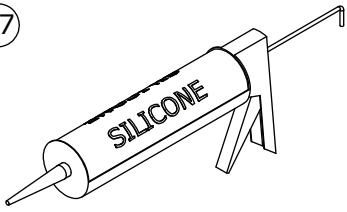

SEQUENCE DE MONTAGE - SEQUENZA DI MONTAGGIO - MONTAGEVOLGORDE  
 SECUENCIA DE MONTAJE - MONTAGEREIHENFOLGE

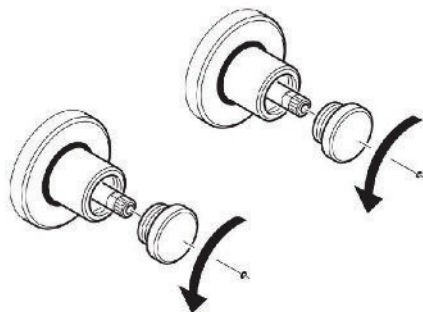
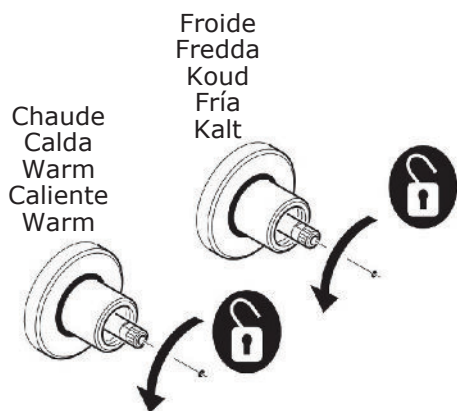
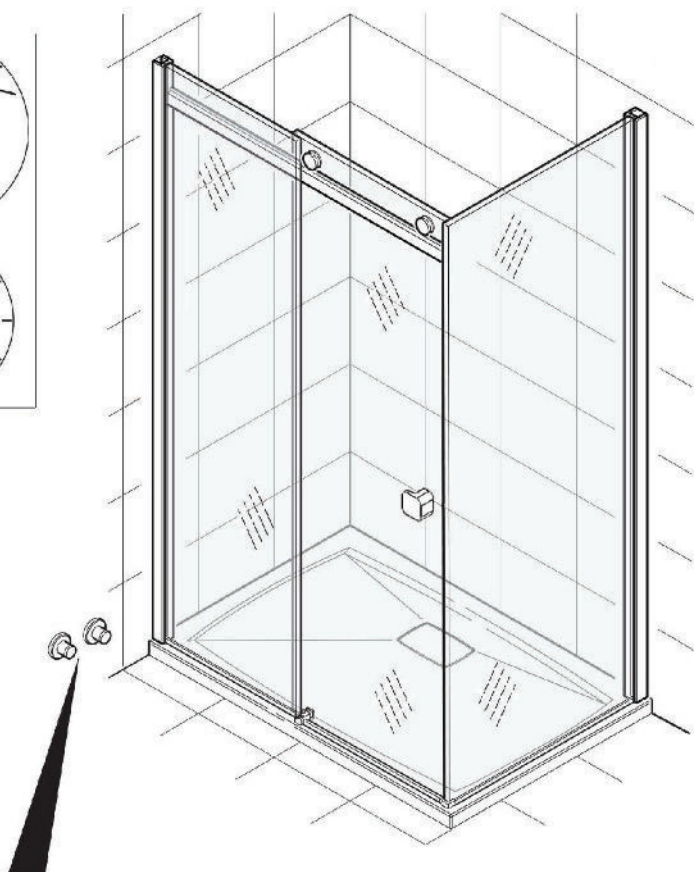
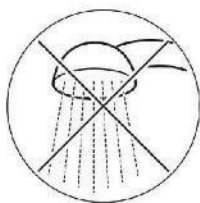

**Informations sur l'utilisation  
 Informazioni sull'utilizzo  
 Informatie over het gebruik  
 Informaciones sobre el uso  
 Informationen über die Verwendung**

Ne pas mettre les mains entre les parois de verre lorsque celles-ci sont coulissées.

Non mettere le mani tra le pareti in vetro mentre scronno.

Steek uw handen niet tussen de glazen wanden wanneer deze worden verschoven.

No ponga las manos entre los cristales mientras se desplazan.

Legen Sie Ihre Hände nicht zwischen die Glaswände während diese geschoben werden.

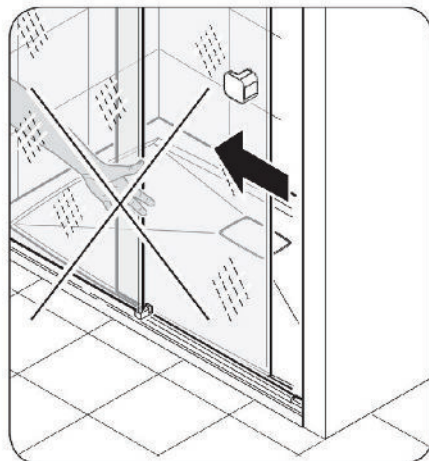

Ne pas s'accrocher à la fermeture de la douche.

Non aggrapparsi alla chiusura doccia.

Ga niet aan de douchesluiting hangen.

No agarrarse al cierre de la ducha.

Nicht an der Duschkabinentür festhalten.

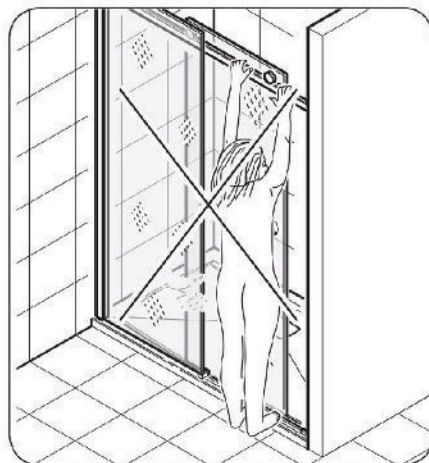

**Informations sur l'utilisation  
 Informazioni sull'utilizzo  
 Informatie over het gebruik  
 Informaciones sobre el uso  
 Informationen über die Verwendung**

Ne pas suspendre d'objet lourds à la fermeture de la douche.

Non appendere oggetti pesanti alla chiusura doccia.

Hang geen voorwerpen aan de douchesluiting.

No colgar objetos pesados en la ducha.

Keine schweren Gegenstände an die Duschkabinentür hängen.

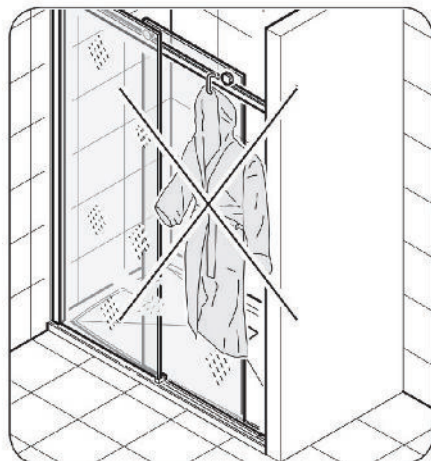

Nettoyer périodiquement le profilé de coulissement et régler périodiquement les roulettes.

Pulire il profilo di scorrimento e regolare le rotelle periodicamente.

Reining het geleiderprofiel en stel de wieltjes regelmatig af.

Limpiar el perfil de deslizamiento y regular las ruedas periódicamente.

Reinigen Sie das Führungsprofil regelmäßig und stellen Sie die Gleitrollen regelmäßig ein

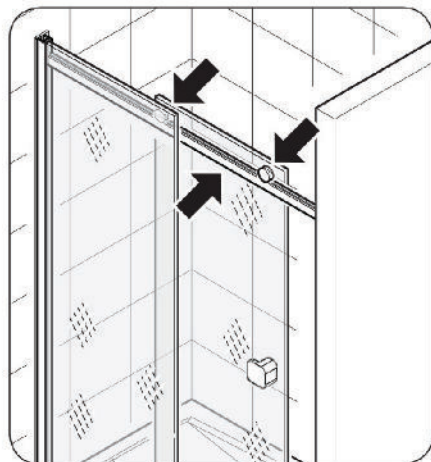

**Nettoyage et entretien**  
**Pulizia e manutenzione**  
**Reinigen en onderhoud**  
**Limpeza y mantenimiento**  
**Reinigung und wartung**

**Nettoyage des parties chromées**  
**Pulizia delle parti cromate**  
**Reinigen van de verchromde onderdelen**  
**Limpeza de las partes cromadas**  
**Reinigung der verchromten Teile**

- Pour nettoyer les surfaces chromées, utiliser **UNIQUEMENT** des détergents liquides neutres.  
 Pour obtenir des surfaces brillantes, appliquer périodiquement une pâte à polir sur un chiffon.



Ne pas utiliser de détergents, de produits abrasifs, d'alcool, de diluants, de substances corrosives ou autres solvants.

- Per la pulizia delle superfici cromate utilizzare **SOLO** detersivi liquidi neutri. Per mantenere lucide le superfici, utilizzare periodicamente un panno e del normale polish.



Non utilizzare detersivi o materiali abrasivi, alcool, diluenti, sostanze corrosive o altri solventi.

- Gebruik voor het reinigen van verchromde oppervlakken **ALLEEN** neutrale reinigingsmiddelen.  
 Om de verchromde oppervlakken glanzend te houden, gebruik regelmatig een doek en conventioneel schoonmaakmiddel.



Gebruik geen schoonmaakmiddelen of schurende materialen, alcohol, verdunners, oplosmiddelen of andere bijtende stoffen.

- Para la limpieza de las superficies cromadas utilizar **ÚNICAMENTE** detergentes líquidos neutros.  
 Para mantener lúcidas las superficies, utilizar periódicamente un paño y un pulimento normal.



No utilizar detergentes ni materiales abrasivos, alcohol, diluyentes, sustancias corrosivas ni otros disolventes.

- Für die Reinigung verchromter Oberflächen sind **AUSSCHLIESSLICH** neutrale Flüssigreiniger zu verwenden.  
 Oberflächen bleiben glänzend, wenn sie regelmäßig mit einem weichen Tuch und Politur gepflegt werden.



Keine Waschmittel, Scheuermittel, Alkohol, Verdünnungsmittel, ätzende Substanzen oder andere Lösungsmittel verwenden.

**Nettoyage et entretien**  
**Pulizia e manutenzione**  
**Reinigen en onderhoud**  
**Limpieza y mantenimiento**  
**Reinigung und wartung**

**Nettoyage des vitres**  
**Pulizia del cristalli**  
**Reinigen van het gals**  
**Limpieza de los cristales**  
**Reinigung der Scheiben**

- Il est conseillé de nettoyer périodiquement de manière approfondie les vitres fixes et la porte.

- Nettoyage journalier  
Rincer abondamment à l'eau froide puis essuyer avec une raclette.
- Nettoyage périodique  
Nettoyer régulièrement à l'aide d'une éponge non-abrasive et de vinaigre blanc, puis essuyer avec un chiffon doux.

 Pour déposer la porte ou la vitre fixe, procéder à l'inverse de la procédure illustrée dans ce manuel.



- Periodicamente si consiglia di effettuare un'accurata pulizia dei cristalli fissi e della porta.

- Pulizia giornaliera  
Risciacquare abbondantemente con acqua fredda e asciugare con una racla in gomma.
- Pulizia periodica  
Pulire regolarmente con una spugna non abrasiva e dell'aceto bianco, quindi asciugare con un panno morbido.

 Se dovesse essere necessario rimuovere la porta o il cristallo fisso, operare in senso inverso a quanto illustrato nel presente manuale.

- Het is raadzaam de glazen wanden en deruren regelmatig en zorgvuldig te reinigen.

- Dagelijkse schoonmaak  
Rijkelijk afspoelen met koud water en vervolgens schoonvegen met een raamwisser.
- Periodieke reiniging  
Schoonmaken met behulp van een niet-schurende spons en met schoonmaakmiddelen, daarna schoonvegen en afdrogen met een zachte doek.

 Als u de deur of het vaste glas dient te verwijderen, ga dan omgekeerd te werk t.o.v. wat is aangegeven in deze handleiding.



**Nettoyage et entretien  
Pulizia e manutenzione  
Reiniging en onderhoud  
Limpieza y mantenimiento  
Reinigung und wartung**

- Periódicamente, se aconseja realizar una limpieza precisa de los cristales fijos y de la puerta.

Para la limpieza, utilizar detergentes comunes para vidrios y cristales.

- Limpieza diaria

Aclarar abundantemente con agua fría y secar con una rasqueta.

- Limpieza periódica

Limpiar con una esponja suave o una bayeta y con vinagre blanco y secar con una gamuza.



Si fuese necesario quitar la puerta o el cristal fijo, opere en sentido inverso a lo ilustrado en este manual.

- Es wird empfohlen, die festen Scheiben und die Tür regelmäßig gründlich zu reinigen.

- Tägliche Reinigung

Mit kaltem Wasser gut abspülen und anschließend mit einem Gummiwischer abziehen.

- Regelmäßige Reinigung

Regelmäßig mit einem nicht scheuernden Schwamm und weißem Essig reinigen und anschließend mit einem weichen Tuch trocken wischen.



Das abnehmen der Tür oder der festen Scheiben erfolgt nachdem in diesem Handbuch gezeigten Verfahren in umgekehrter Reihenfolge.

**Nettoyage et entretien**  
**Pulizia e manutenzione**  
**Reiniging en onderhoud**  
**Limpieza y mantenimiento**  
**Reinigung und wartung**

**Nettoyage de la bonde**  
**Pulizia piletta di scarico**  
**Reinigen van douche-afvoer**  
**Limpieza del desagüe**  
**Reinigung des Bodenablaufs**

- Retirer périodiquement le bouchon de la bonde de vidage et vérifier que le bol placé en dessous soit propre.  
 Eliminer d'éventuels résidus (cheveux, fils, etc...) et remettre en place.  
 Selon le modèle, reportez-vous au manuel du receveur.
- Periodicamente rimuovere il tappo della piletta di scarico e controllare che il bicchiere sottostante sia pulito.  
 Rimuovere eventuali residui (peli, fili, etc) e riposizionare il tutto.  
 A seconda del modello, consultare il manuale del piatto doccia.
- Verwijder regelmatig het dekseltje van de douche-afvoer en controleer of het onderliggende vaatje schoon is.  
 Verwijder eventuele resten (haren, draden, enz.) en plaats alle onderdelen terug.  
 Afhankelijk van het model, zie de handleiding van de douchebak.
- Periódicamente, quitar el embellecedor del desagüe y controlar que el vaso del desagüe esté limpio.  
 Quitar los posibles residuos (pelos, hilos, etc.) y volver a colocar todo.  
 Según el modelo, consulte el manual del plato de ducha.
- Regelmäßig den Ablaufverschluss entfernen und den Einsatz auf Verschmutzung überprüfen.  
 Eventuelle Rückstände entfernen (Haare, Fasern usw.) und Verschluss wieder einsetzen.  
 Weitere Informationen zum jeweiligen Modell finden Sie im Handbuch zur Duschwanne.

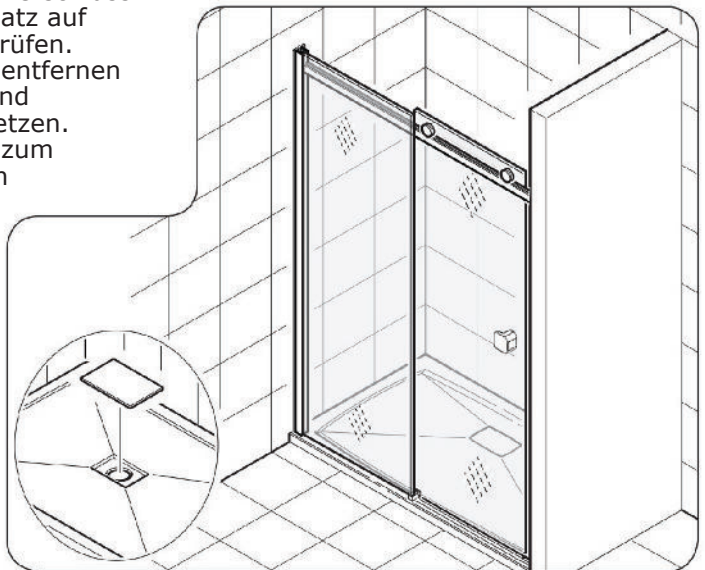





**SERVICE APRES-VENTE  
ASSISTENZA POST-VENDITA  
DIENST NA VERKOOP  
ASISTENCIA POSTVENTA**



**CE**

**FRANCE**

**02 40 21 29 45**

**UK**

**020 8842 0033**

**IRELAND**

**04697 33102**

**DEUTSCHLAND**

**+49 (0) 6074 / 30928 0**

**ITALIA**

**(0382) 6181**

**ÖSTEREICH**

**+43 1 710 60 70**

**SCHWEIZ**

**(01) 748 17 44**

**ESPANA**

**93 544 60 76**

**NEDERLAND**

**+31 475 487 100**

**BELGIË**

**+31 475 487 100**

**BELGIQUE**

**+31 475 487 100**

**РОССИЯ**

**963 19 40, 773 67 22**