

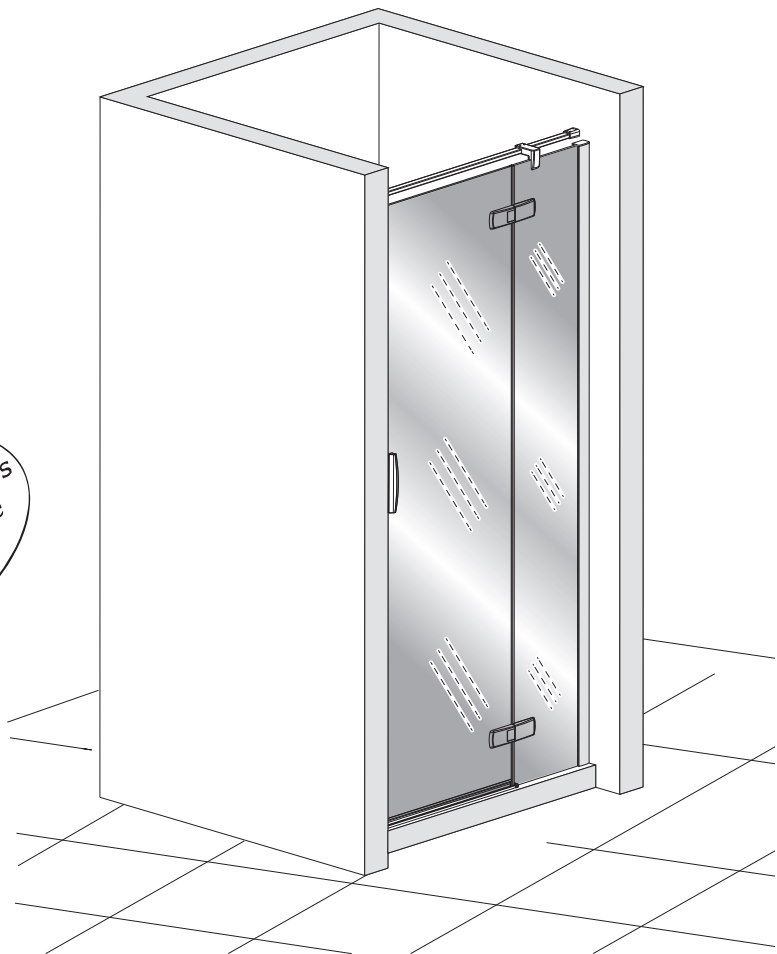

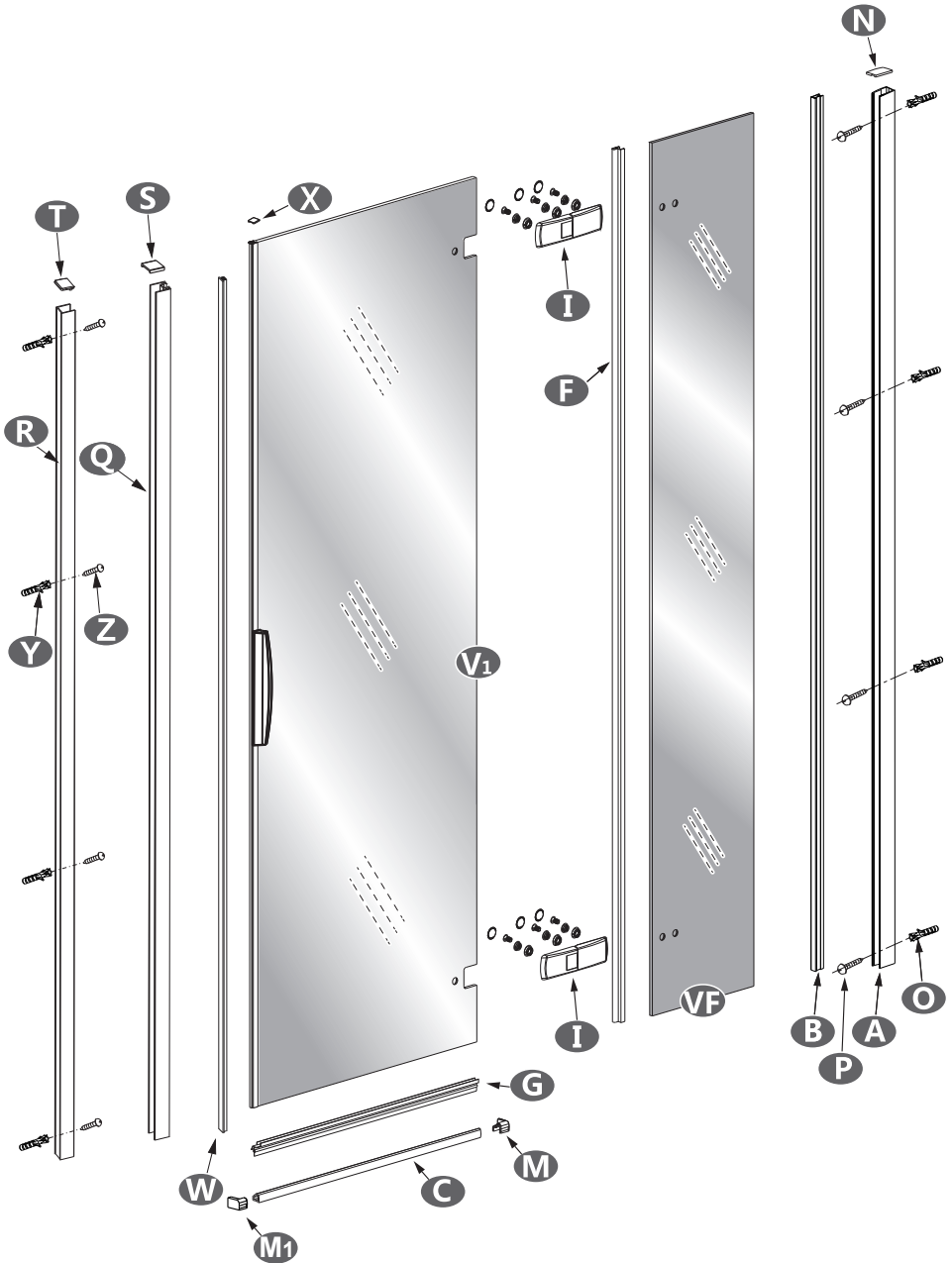







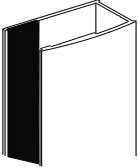
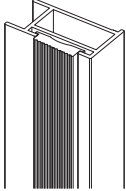
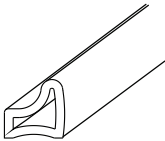
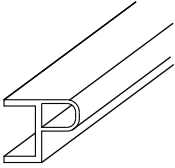
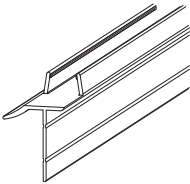
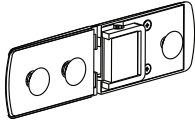
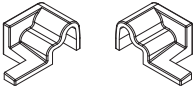

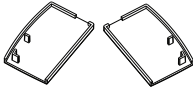
Notice de montage
Installation instructions
Manual de instalación
Istruzioni di montaggio
Montage-instructies
Montageanleitung

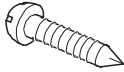

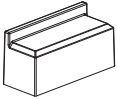
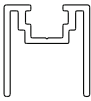

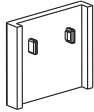

Attention aux étapes :
Check installation steps :
Atención a los pasos :
Attenzione ai passi :
Aandacht voor de stappen :
Achtung vor den Schritten :

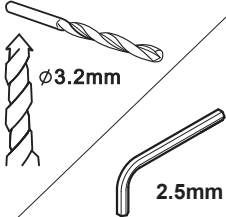
P. 8 - 11 - 33

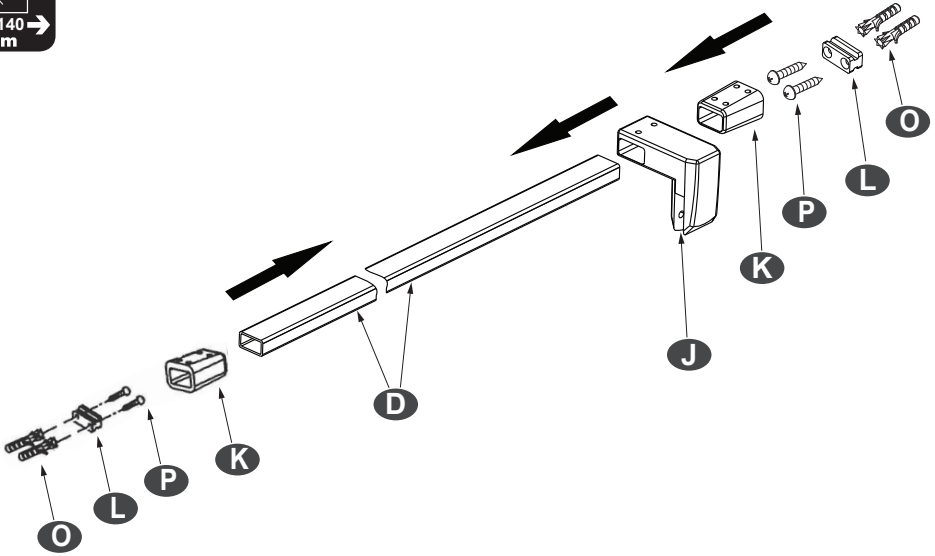

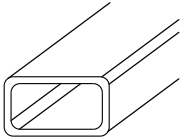
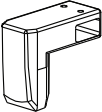

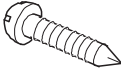

<p>(A) x1</p>  <p>6346</p>	<p>(B) x1</p>  <p>6347</p>	<p>(C) x1</p>  <p>6345</p>	
<p>(F) x1</p>  <p>JOI327</p>	<p>(G) x1</p>  <p>JOI325</p>	<p>(I) x2</p>  <p>CHAR26</p>	
<p>(M) x2</p>  <p>SET183</p>	<p>(M1) x2</p>  <p>SET158</p>	<p>(N) x2</p>  <p>SET159</p>	
<p>(O) x8</p> 	<p>(P) x8</p>  <p>ST4x40</p>	<p>(X) x1</p>  <p>PPL1354</p>	
<p>(P1) x2</p>  <p>CAL133</p>	<p>(Q) x1</p>  <p>6348</p>	<p>(R) x1</p>  <p>6349</p>	<p>(S) x1</p>  <p>PPL1352</p>
<p>(T) x1</p>  <p>PPL1353</p>	<p>(W) x1</p>  <p>AIM61</p>	<p>(Z) x4</p>  <p>ST4x30</p>	 <p>ø3.2mm</p> <p>2.5mm</p>

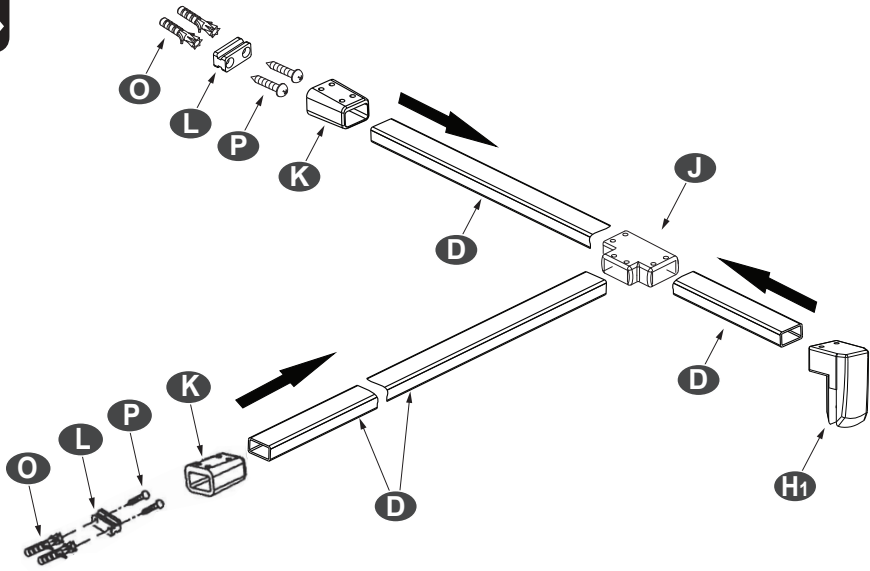

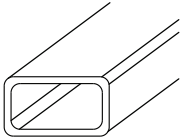
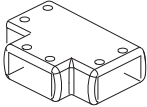
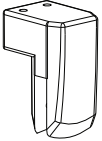
<p>(D) x1</p>  <p>6350</p>	<p>(J) x1</p>  <p>SUP195</p>	<p>(K) x2</p>  <p>SUP196</p>
<p>(L) x2</p>  <p>SUP197</p>	<p>(O) x4</p> 	<p>(P) x4</p>  <p>ST4x40</p>



<p>(D) x2</p>  <p>6350</p>	<p>(J) x1</p>  <p>SUP201</p>	<p>(H1) x1</p>  <p>SUP202</p>
<p>(K) x2</p>  <p>SUP196</p>	<p>(L) x2</p>  <p>SUP197</p>	<p>(O) x4</p> 
<p>(P) x4</p>  <p>ST4x40</p>		

Outils nécessaires (non fournis)
Necessary tools (not supplied)
Herramientas necesarias (no suministradas)
Attrezzi necessari (non forniti)
Erforderliches Werkzeug (wird nicht mitgeliefert)
Benodigdheden (niet meegeleverd)

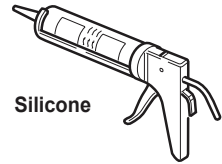
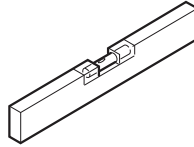
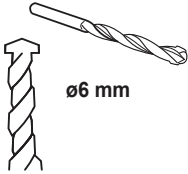
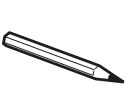

Silicone

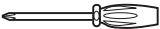
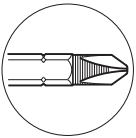
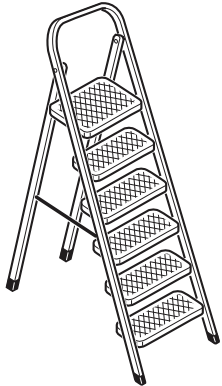
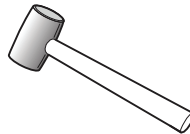
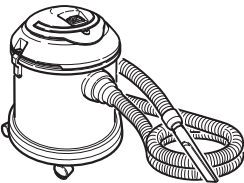

Réversibilité - Reversibility - Reversibilidad
Reversibilida - Omkeerbaarheid - Wahlweise Montage

Montage à gauche
Left hand
Montaje a la izquierda
Montaggio a sinistra
Montage links
Montage links

Montage à droite
Right hand
Montaje a la derecha
Montaggio a destra
Montage rechts
Montage rechts

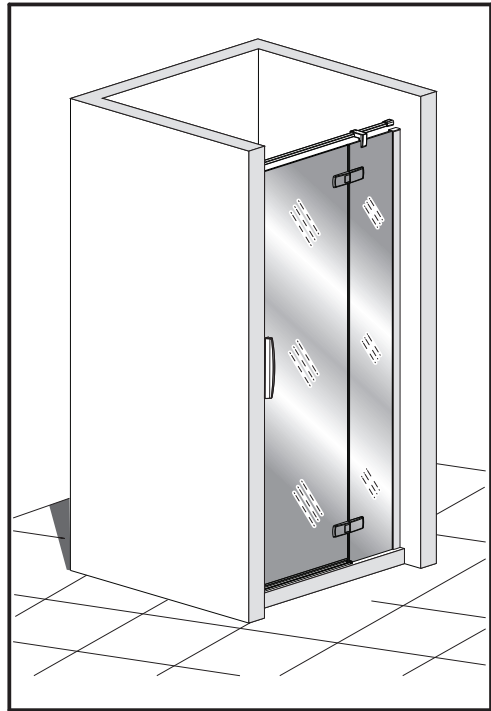
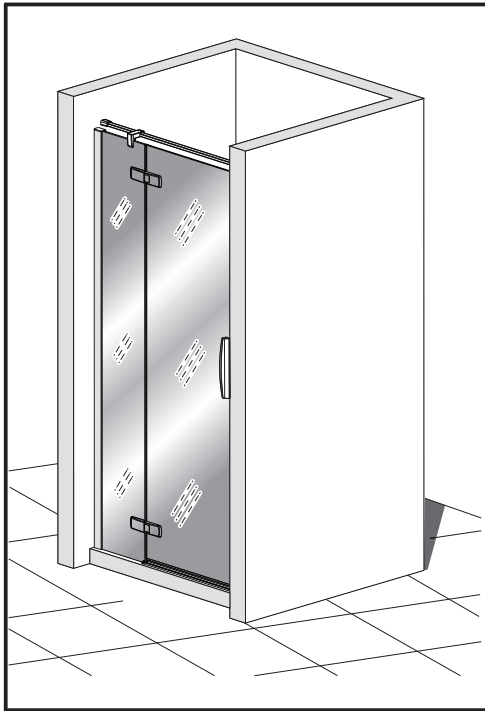

Vous avez la possibilité de réaliser un montage à droite ou un montage à gauche. Notre notice d'installation décrit un montage à droite. Si vous voulez réaliser un montage à gauche, il vous suffit d'inverser le montage.

This cubicle can be installed either left or right hand. These installation instructions show a right hand installation.

Puede realizar un montaje a la derecha o un montaje a la izquierda. Nuestro folleto de instalación describe un montaje a la derecha. Si desea montar su cabina a la izquierda sólo tendrá que realizar el montaje al contrario.

Avete la possibilità di effettuare il montaggio a destra o a sinistra. Il nostro manuale descrive il montaggio a destra. Se volete realizzare il montaggio a sinistra è sufficiente invertire varie fasi di montaggio.

U kunt de douchecabine rechts of links monteren. Onze handleiding beschrijft de rechts montage van de cabine. Keer de montage om als u de cabine links wilt monteren.

Sie haben die Möglichkeit, eine Montage auf der linken Seite oder eine Montage auf der rechten Seite durchzuführen. Unsere Montageanleitung beschreibt eine Montage auf der rechten Seite. Wenn Sie die Montage lieber auf der linken Seite durchführen wollen, müssen Sie nur den Montageprozess umkehren.

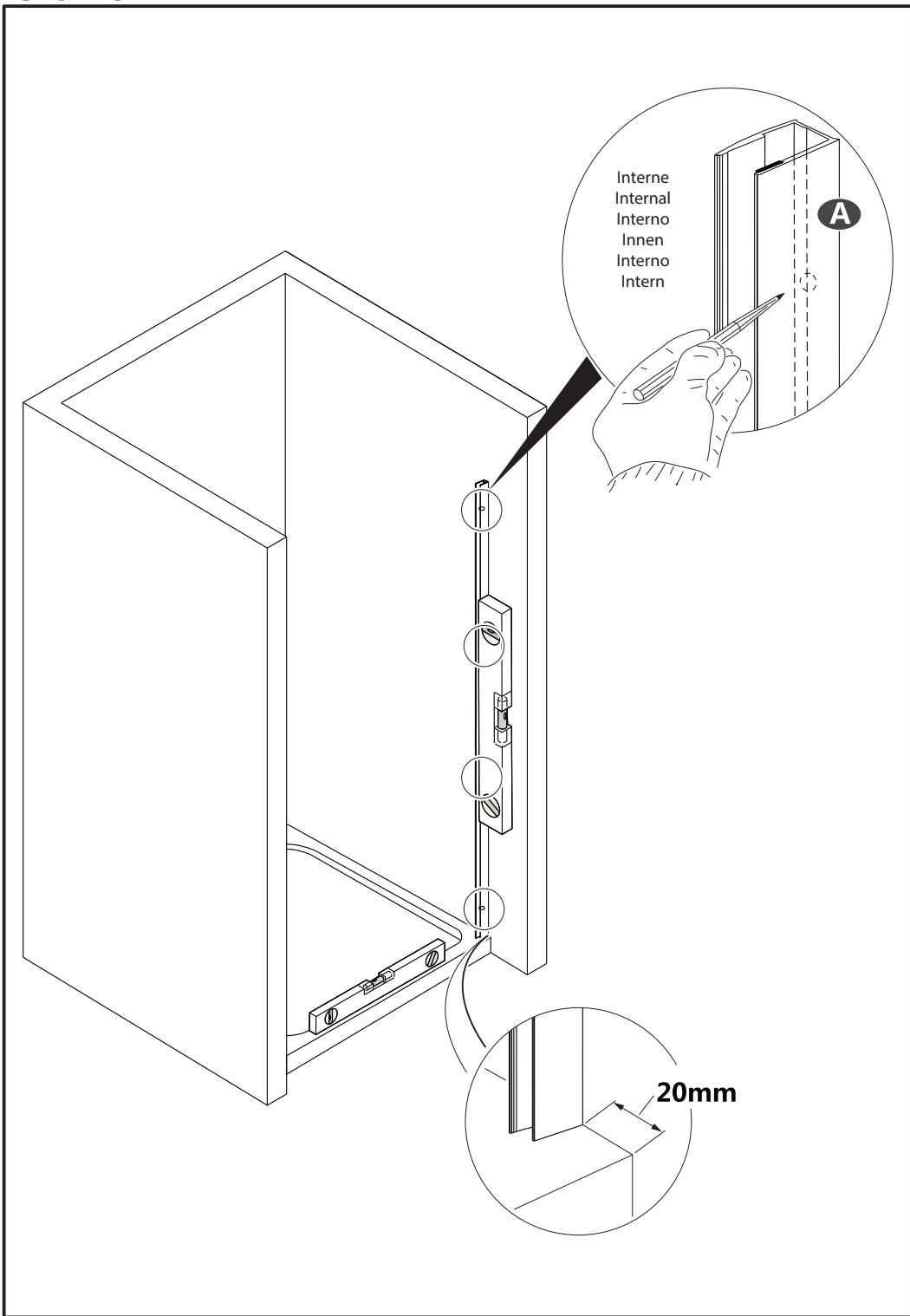

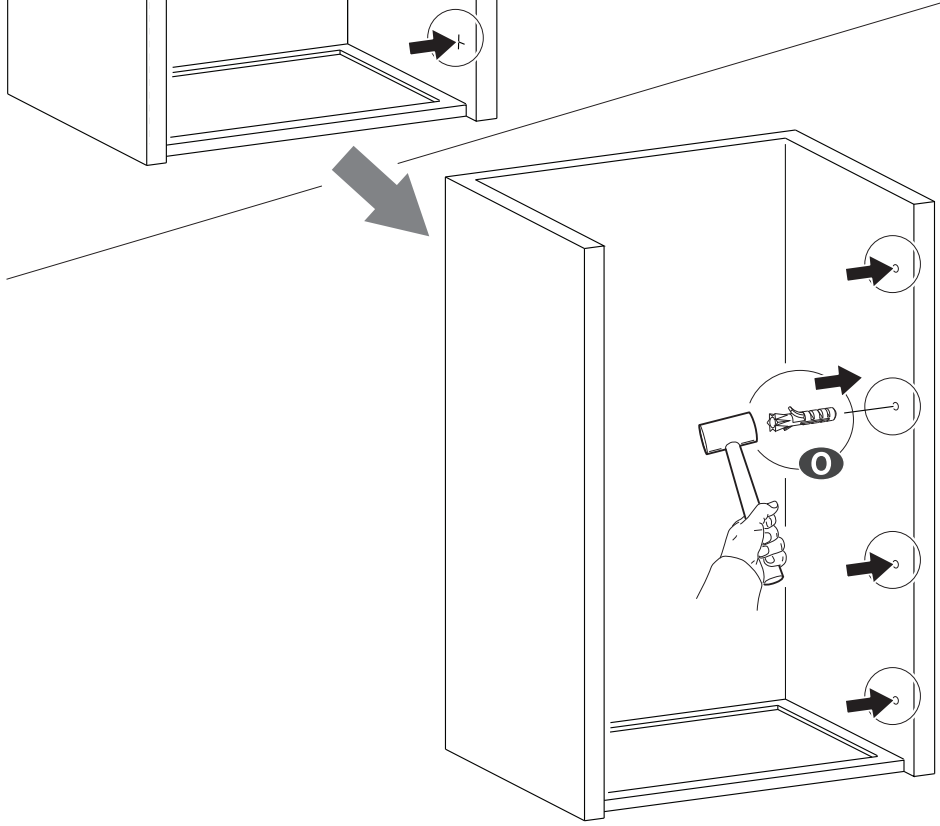
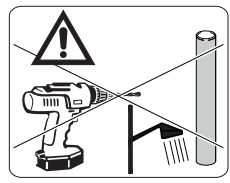
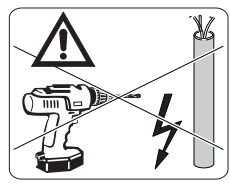
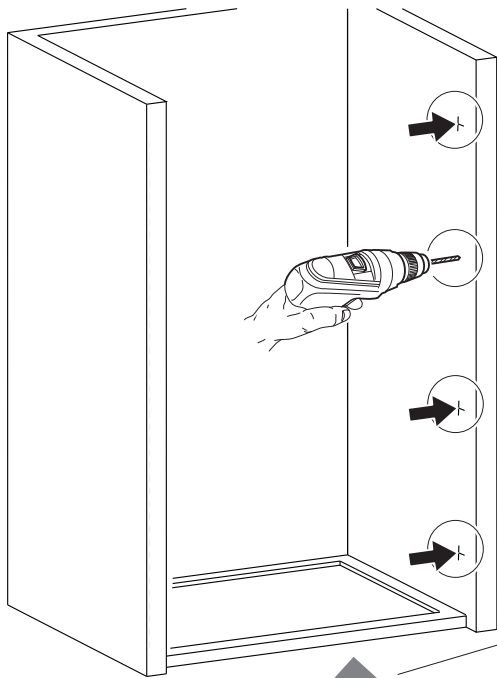

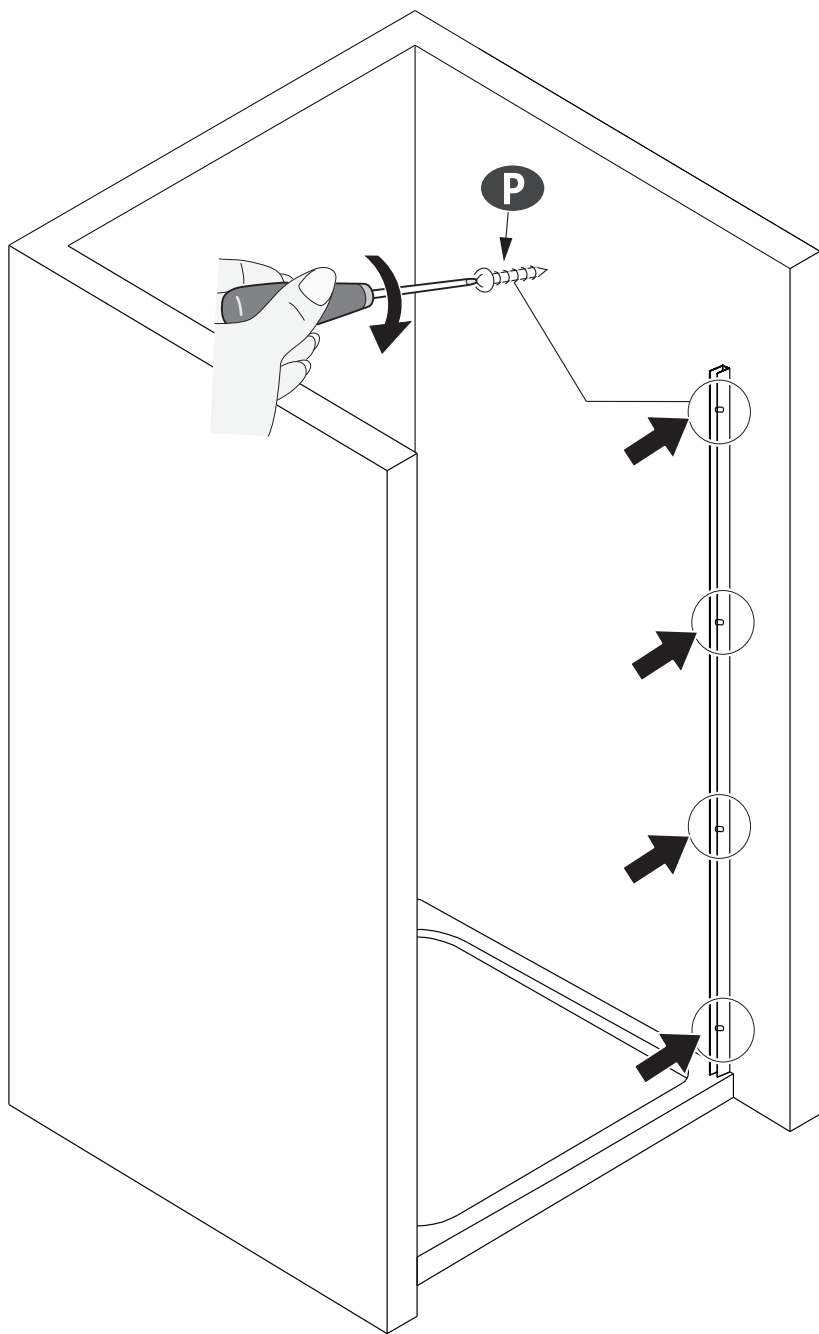

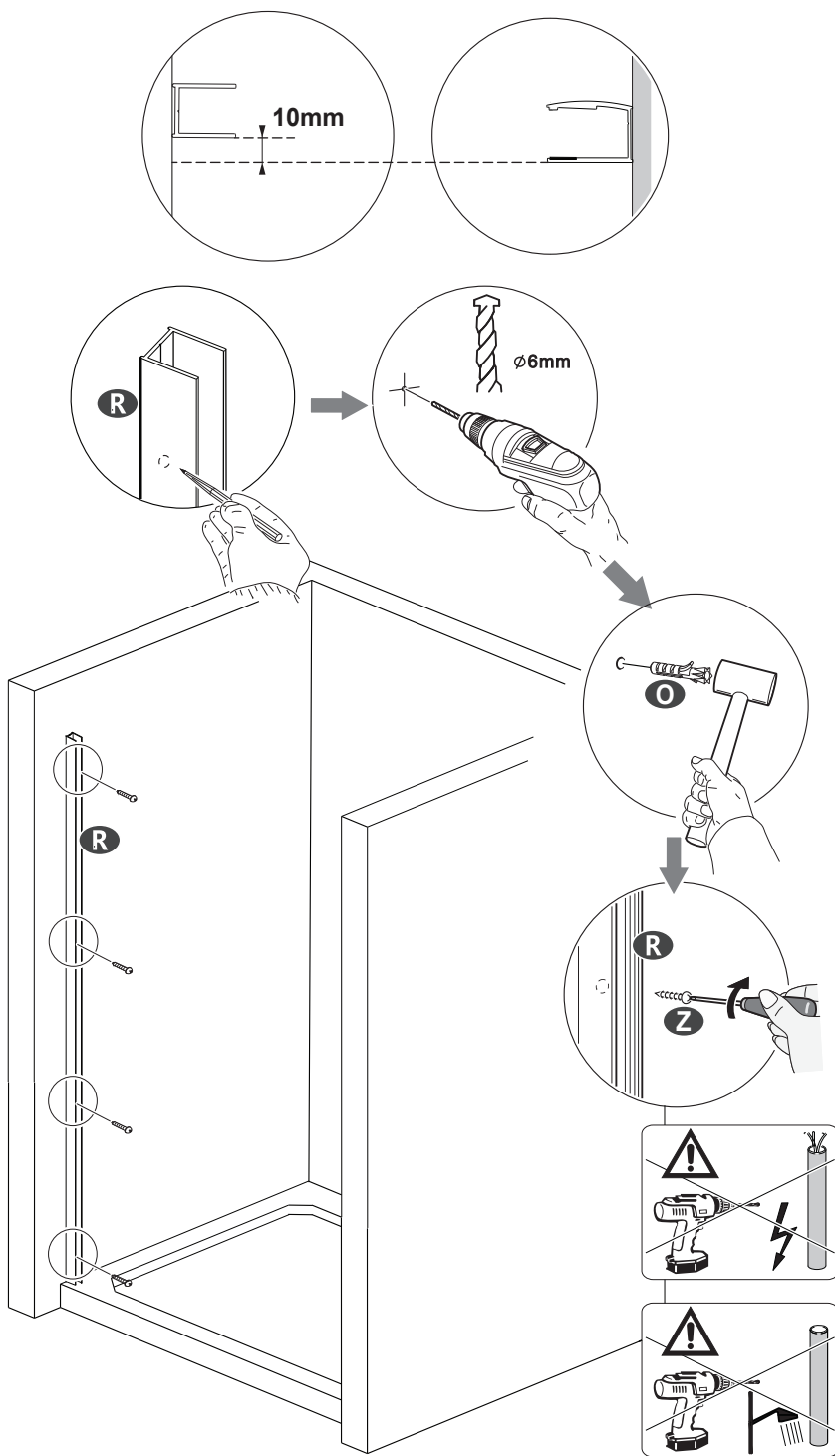

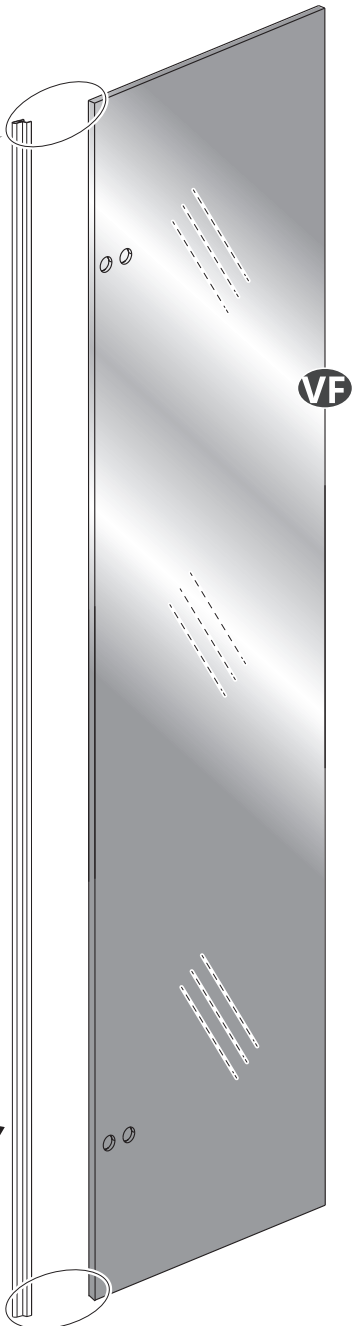
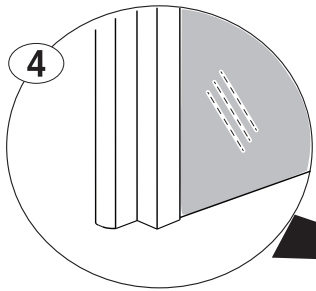
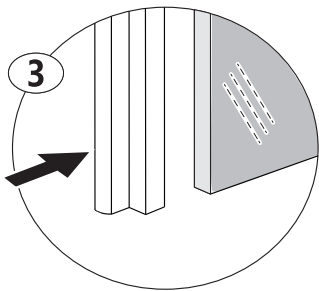
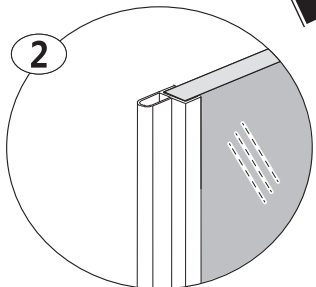
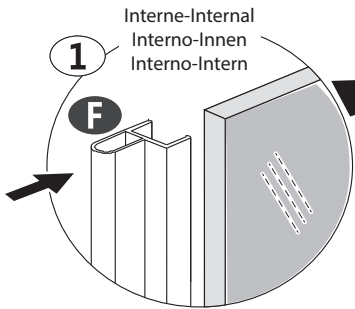

Interne
Internal
Interno
Innen
Interno
Intern

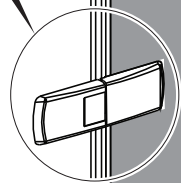
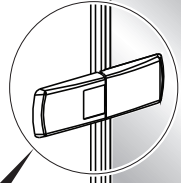
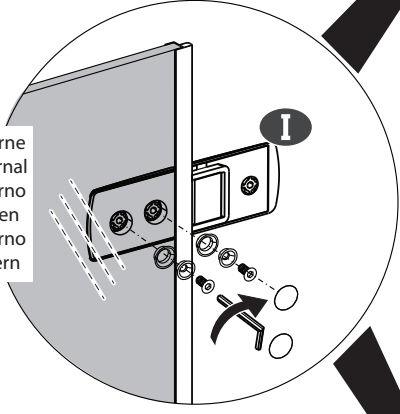

VF

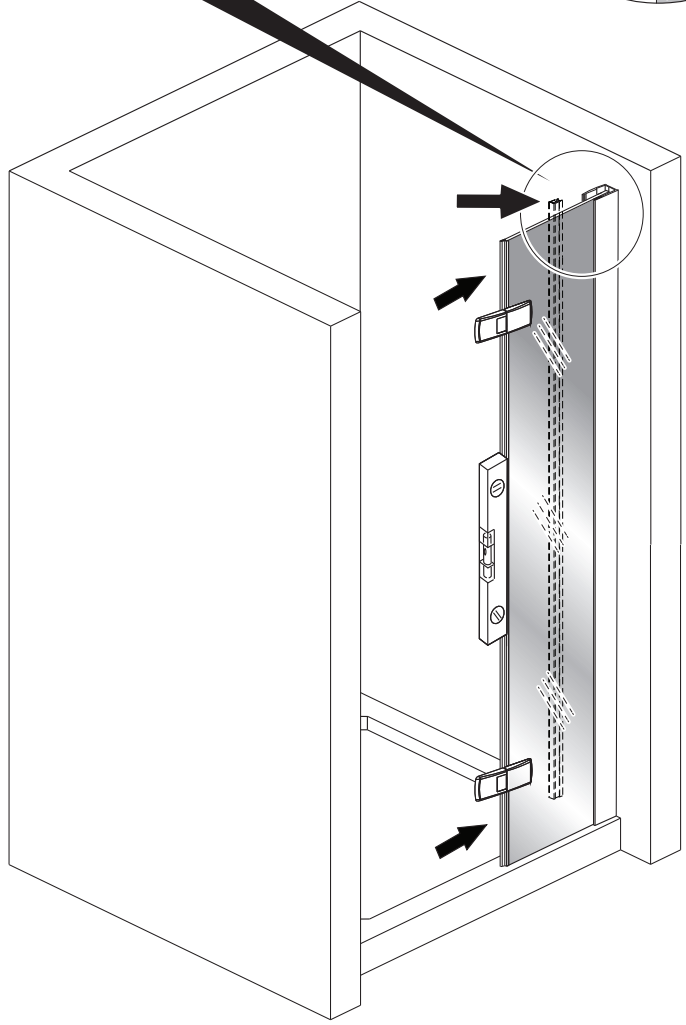
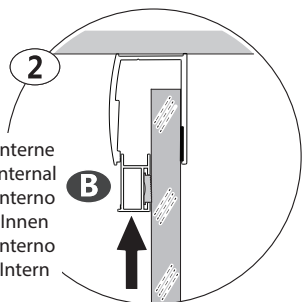
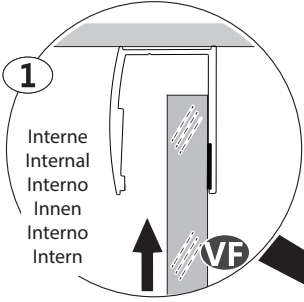

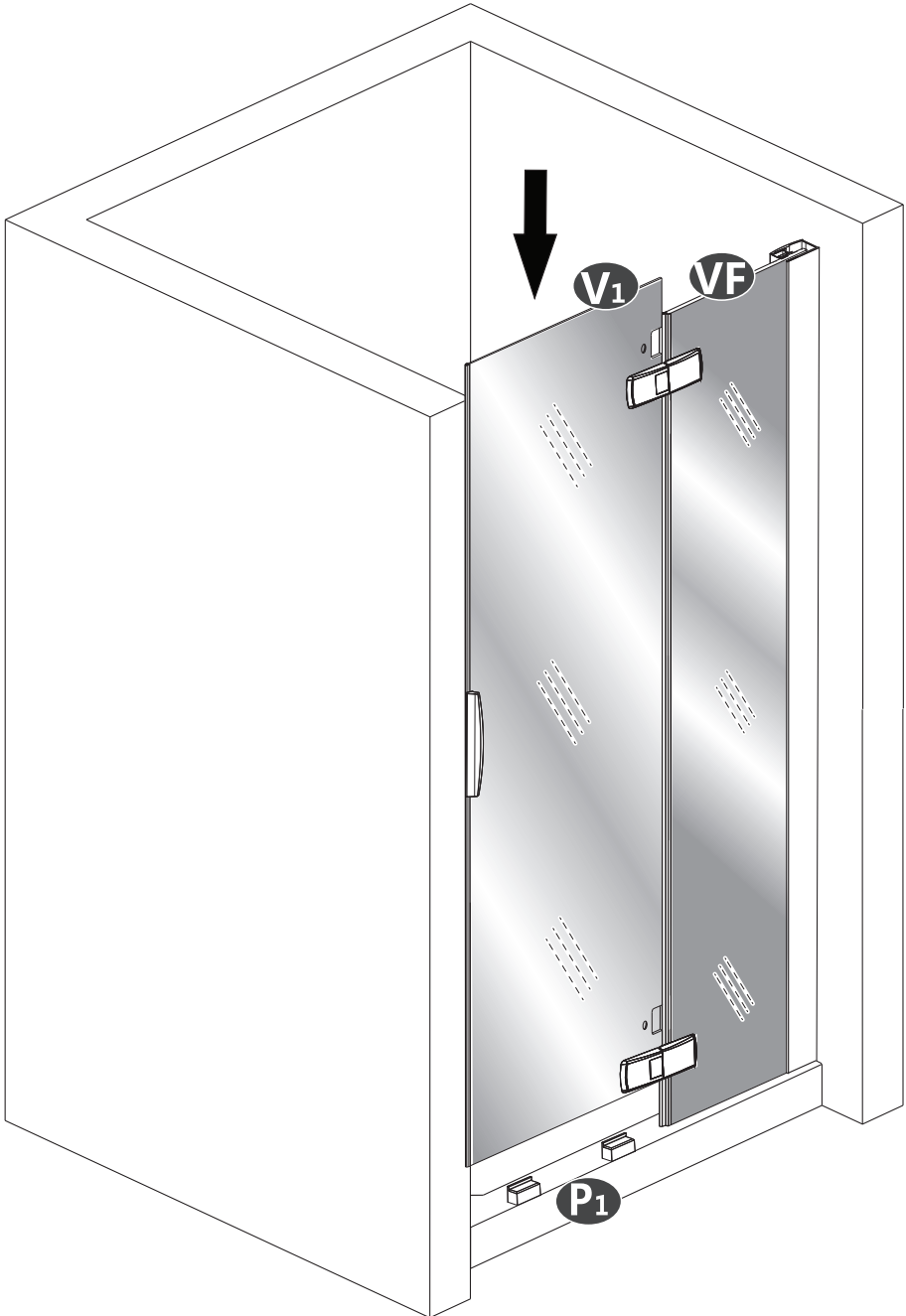

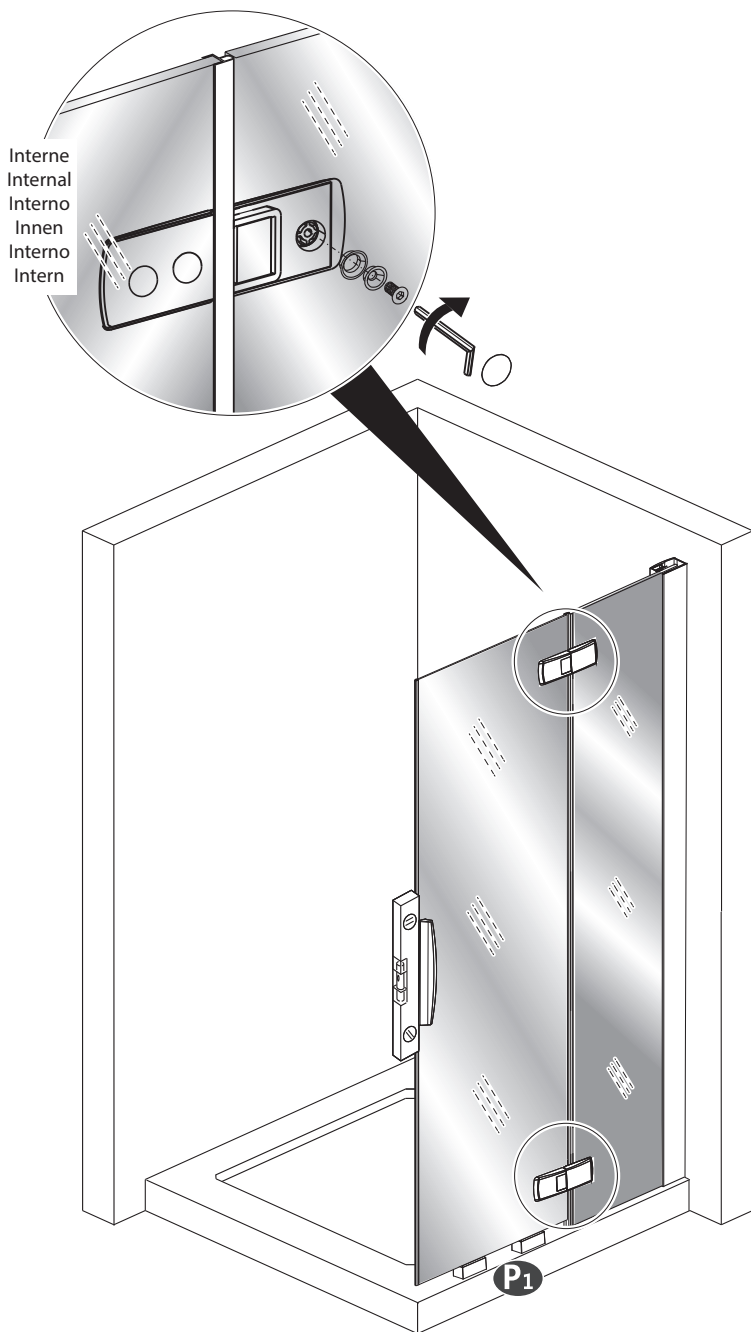

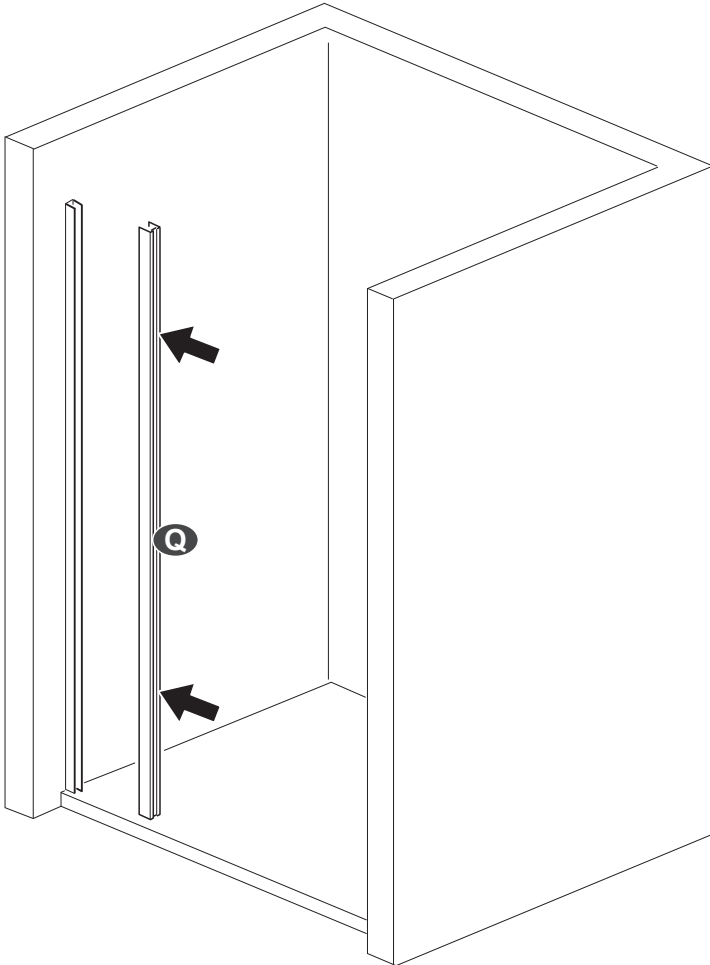
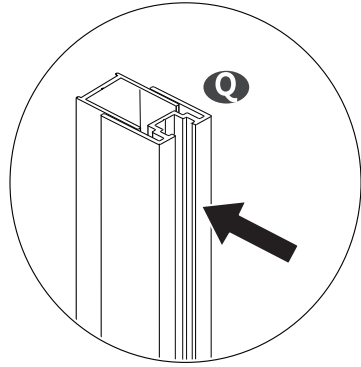

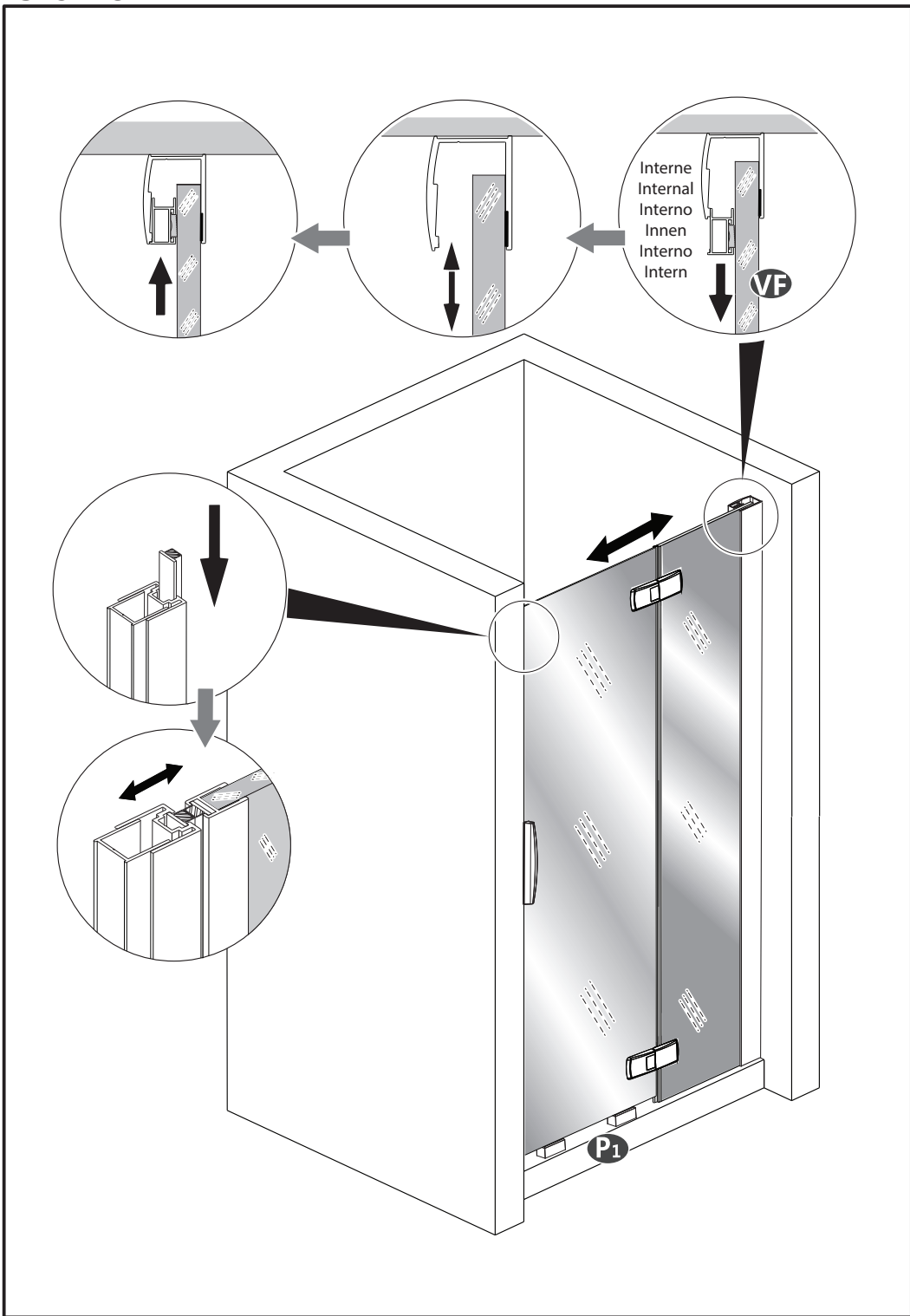

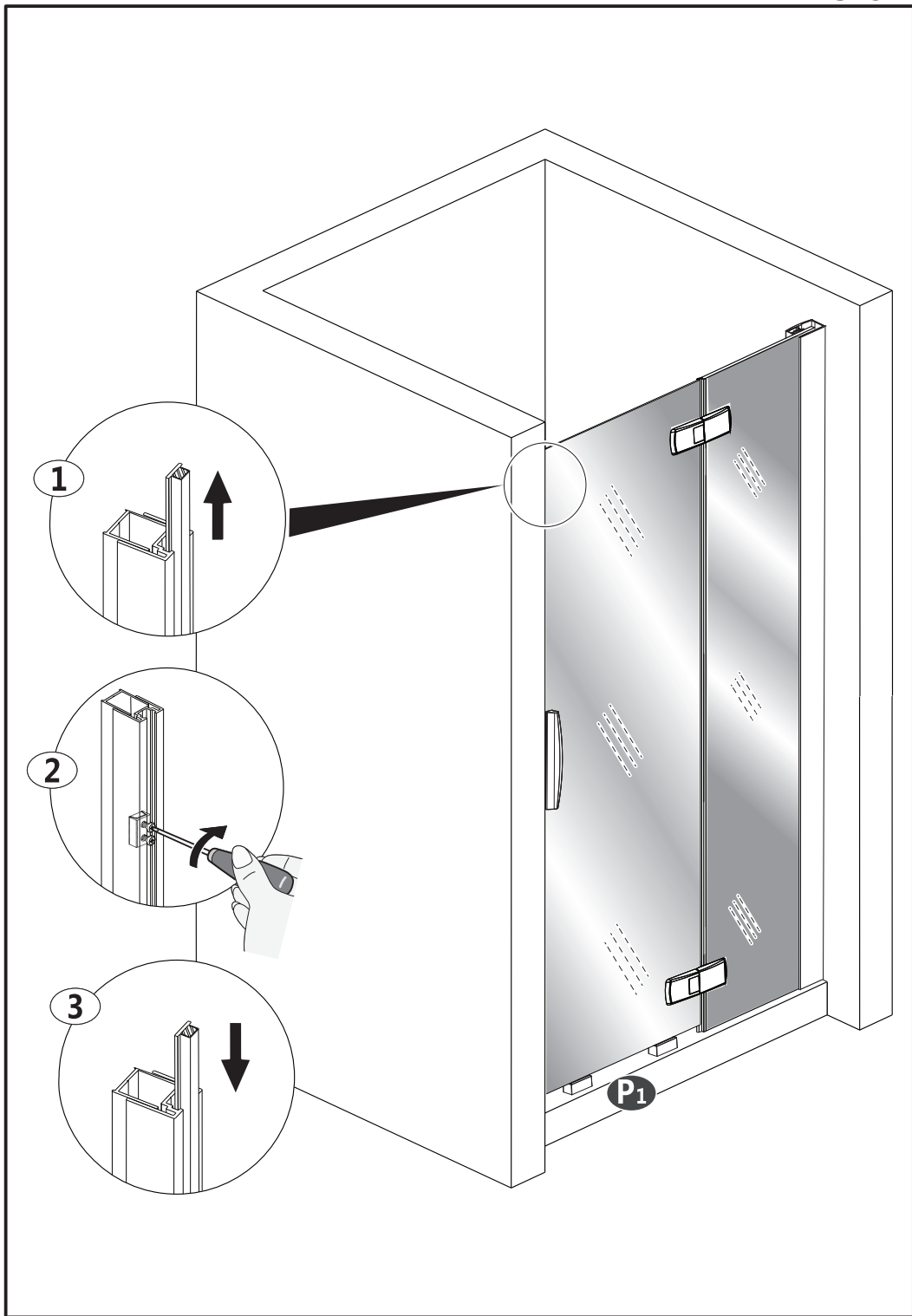

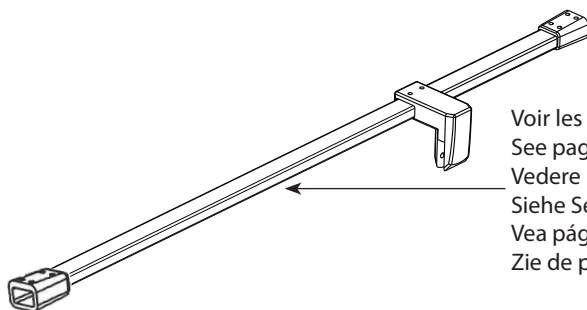

Voir les pages **21 - 24**
 See pages **21 - 24**
 Vedere pagine **21 - 24**
 Siehe Seite **21 - 24**
 Veá páginas **21 - 24**
 Zie de pagina's **21 - 24**

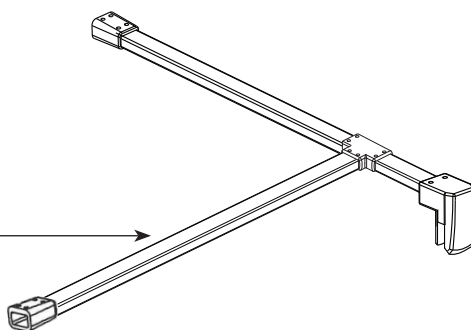

Voir les pages **25 - 29**
 See pages **25 - 29**
 Vedere pagine **25 - 29**
 Siehe Seite **25 - 29**
 Veá páginas **25 - 29**
 Zie de pagina's **25 - 29**

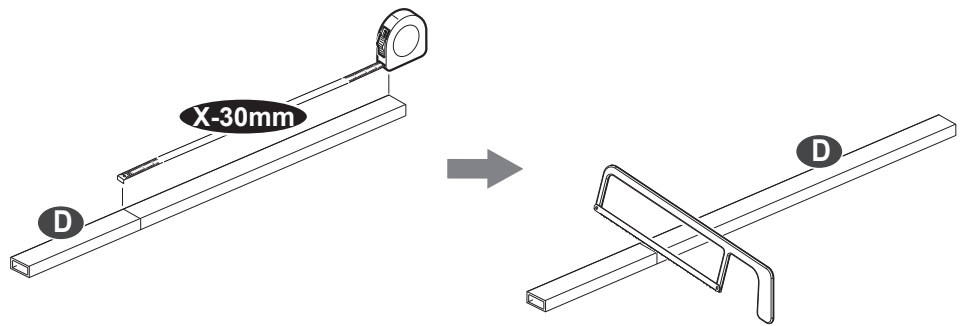
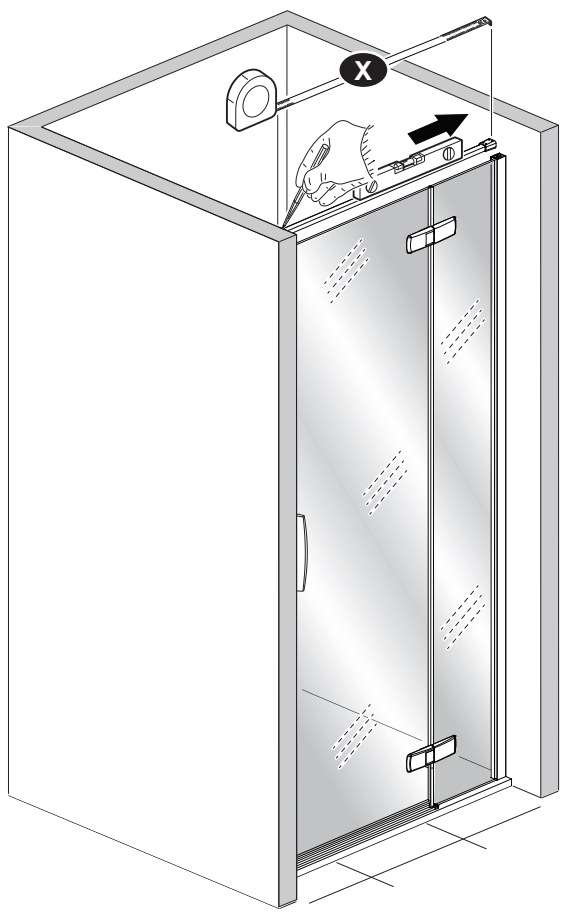

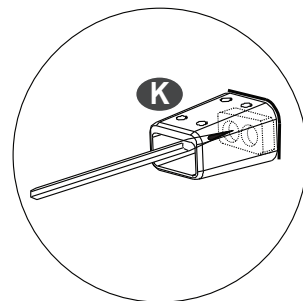
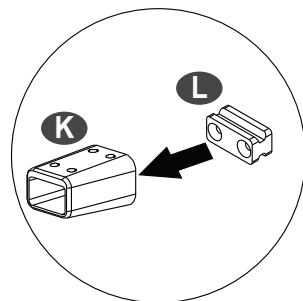
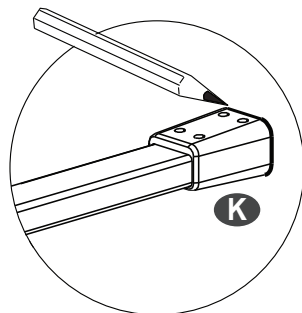
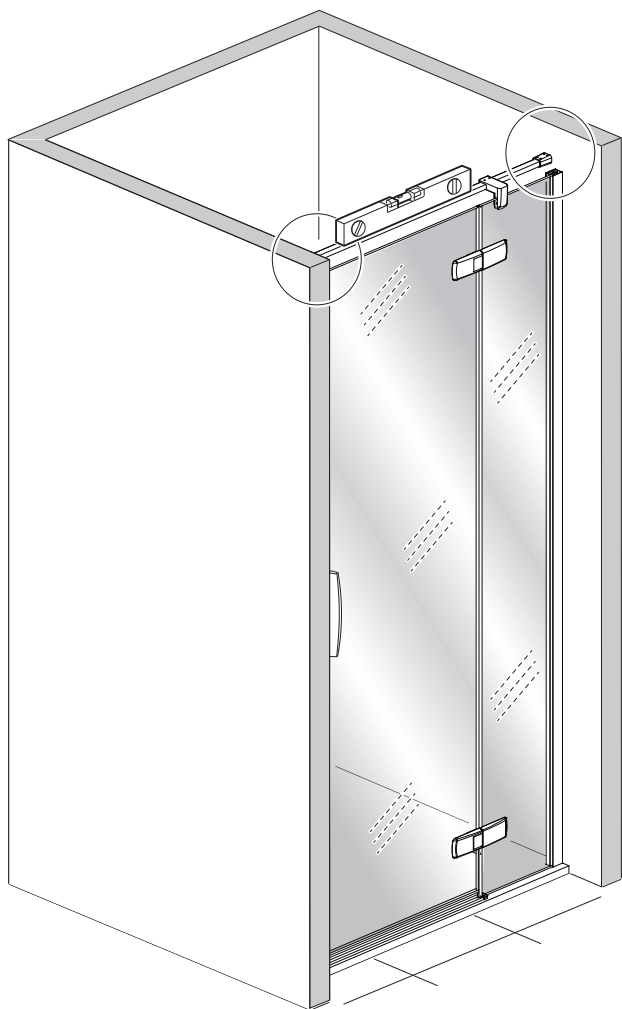

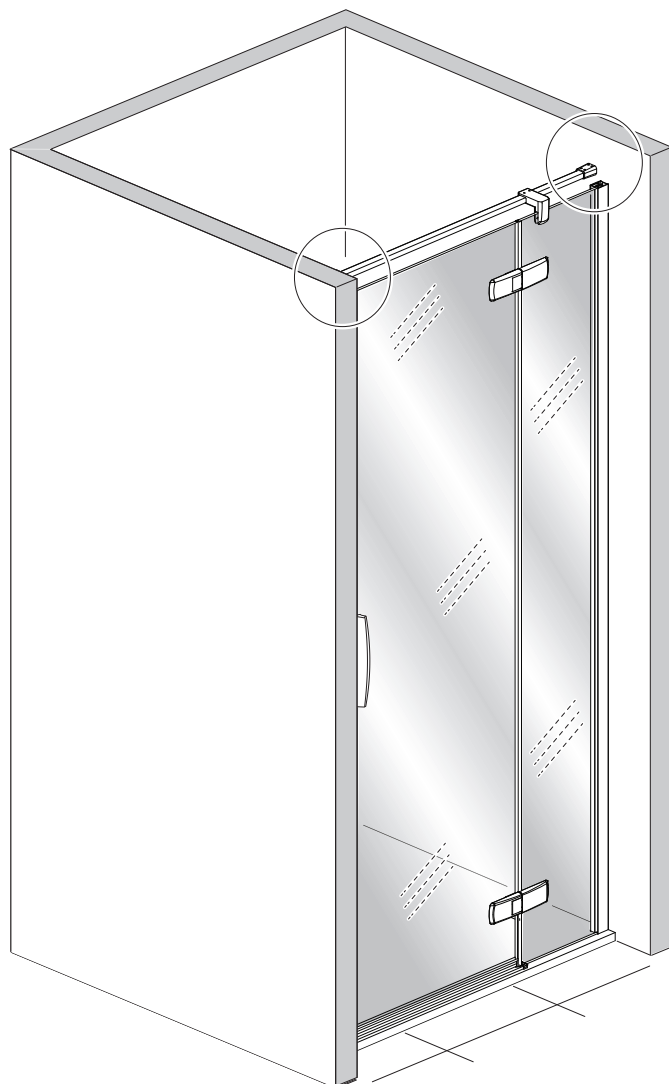
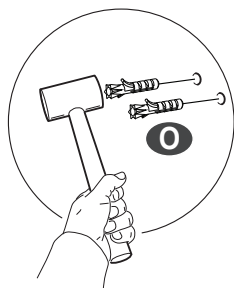
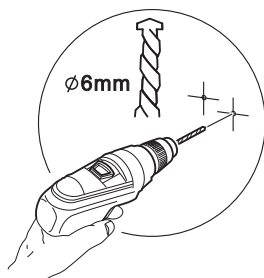
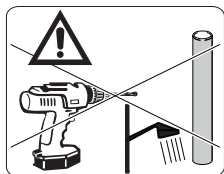
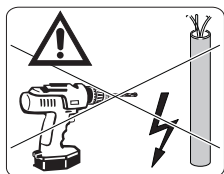

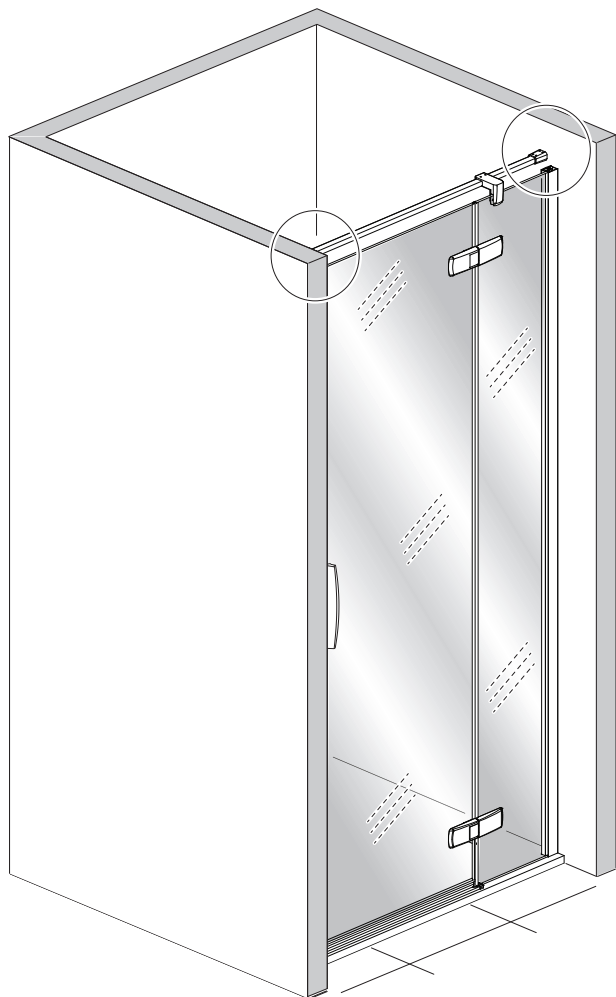
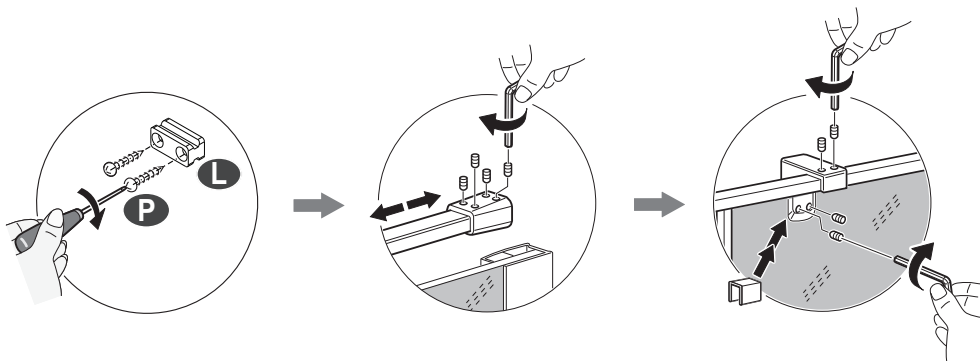

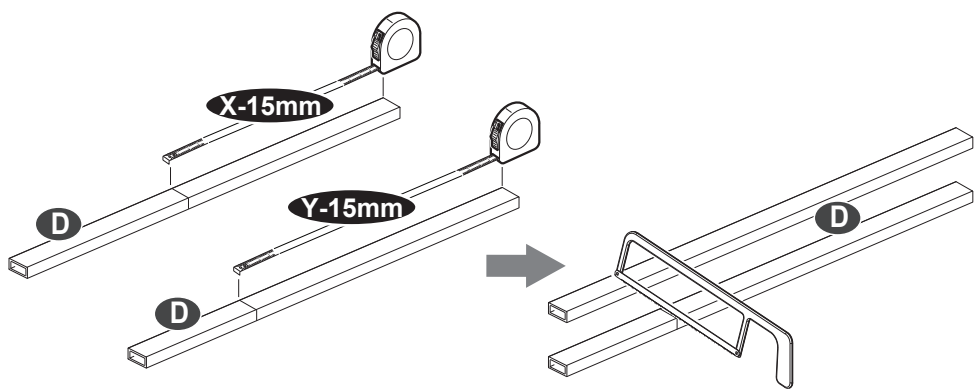
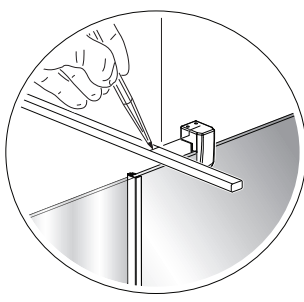
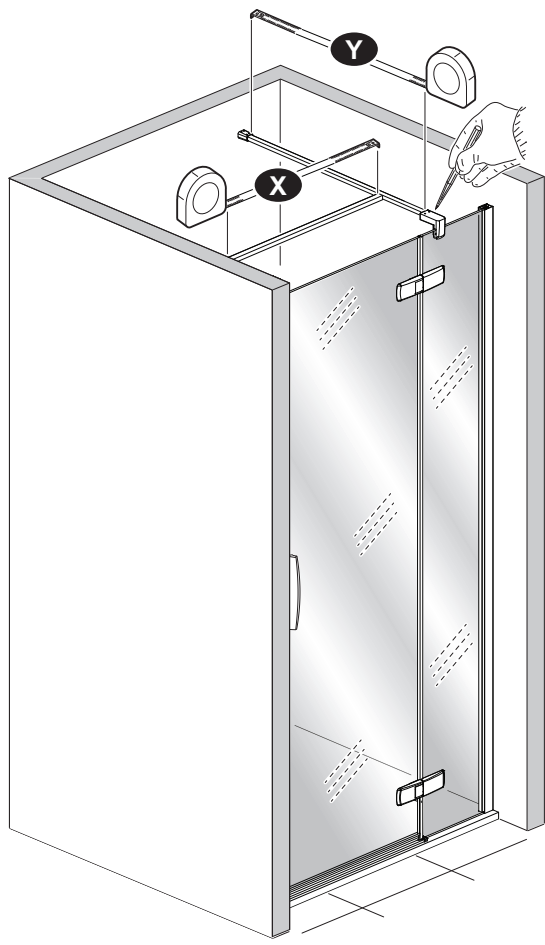

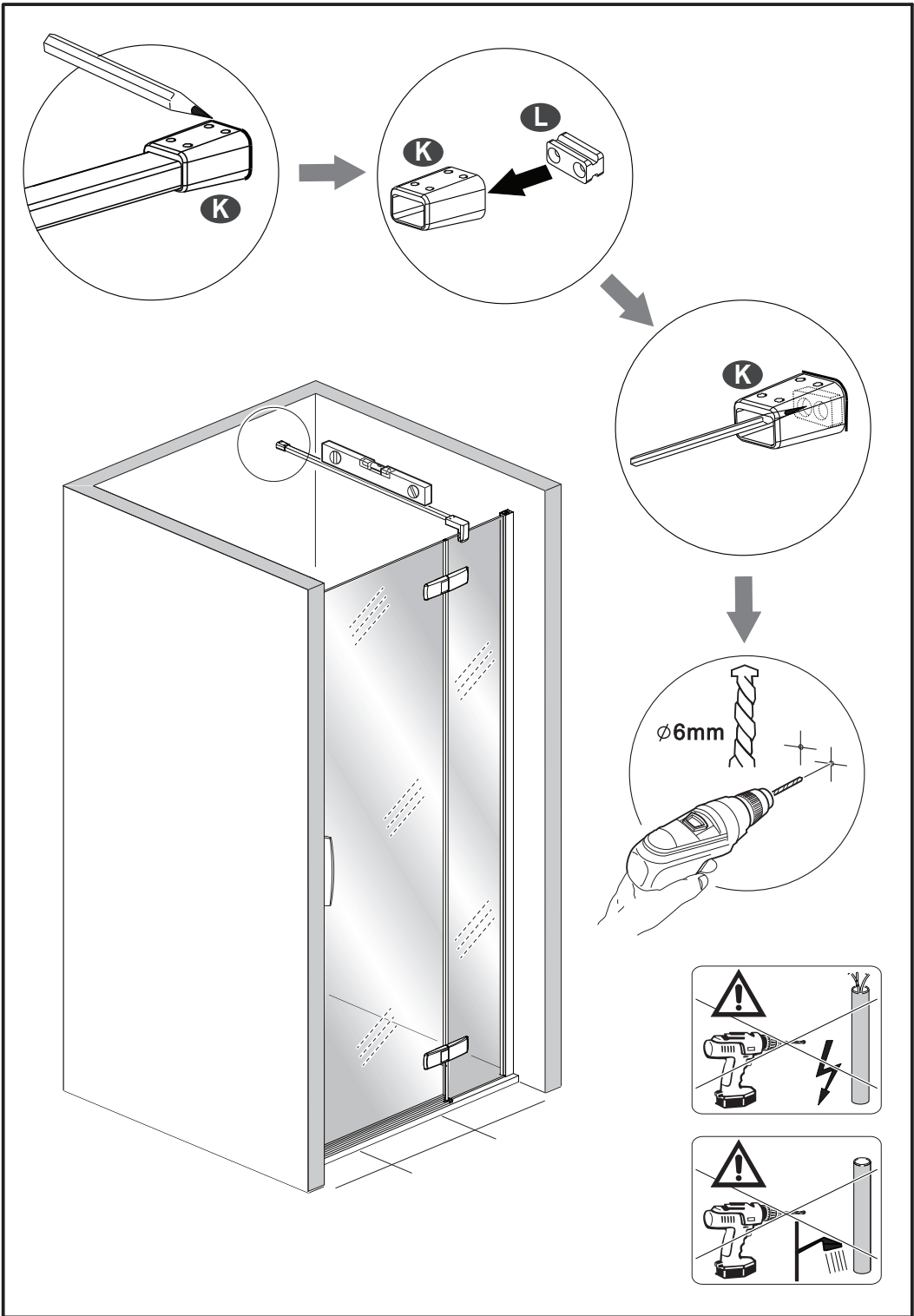

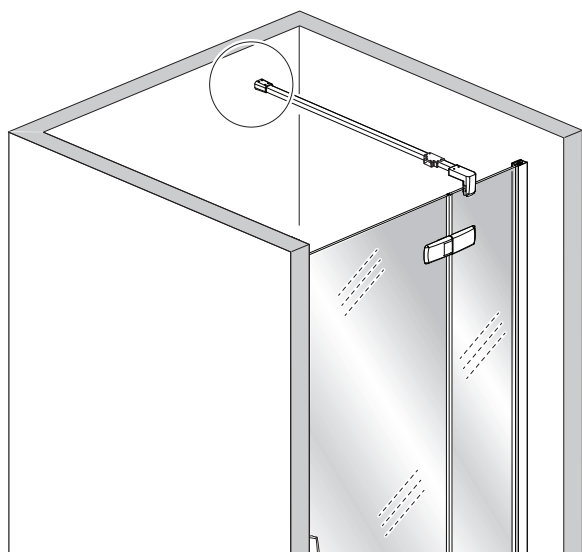
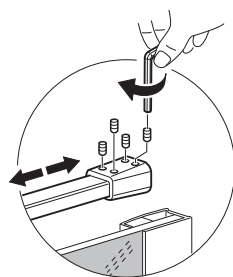
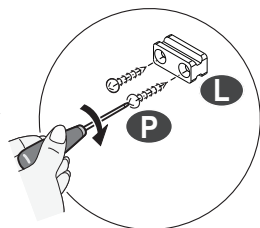
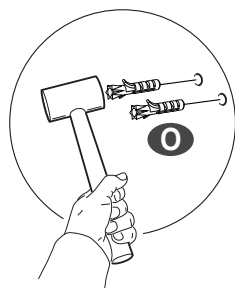
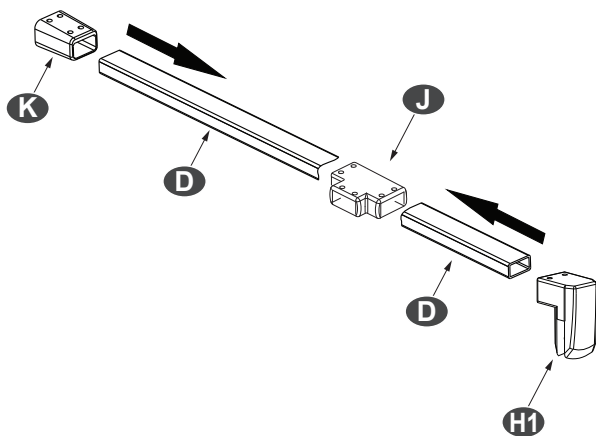

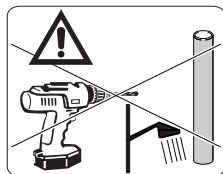
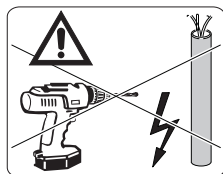
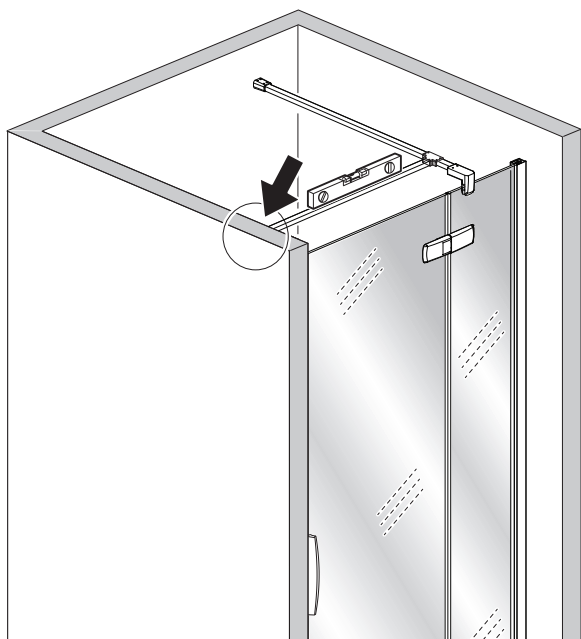
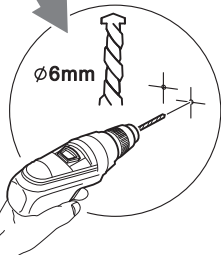
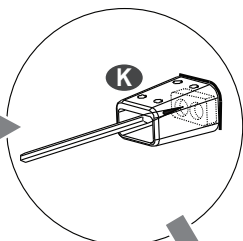
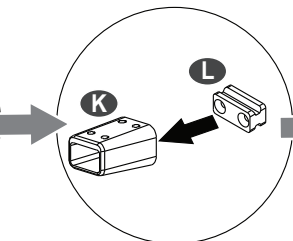
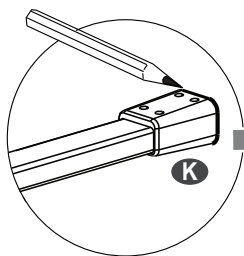
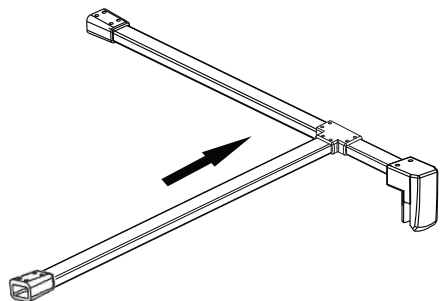

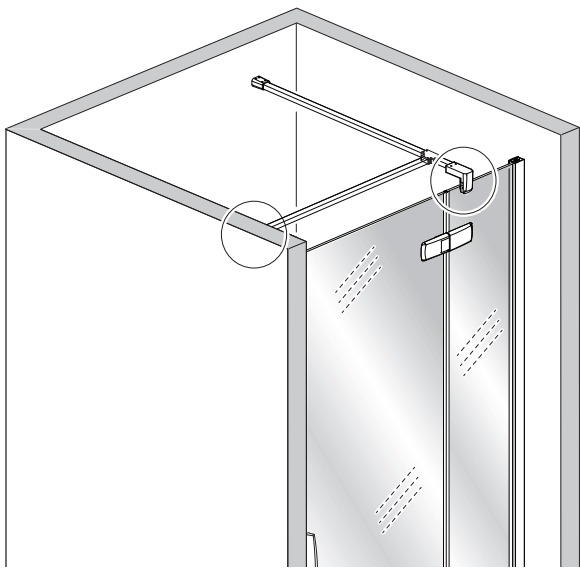
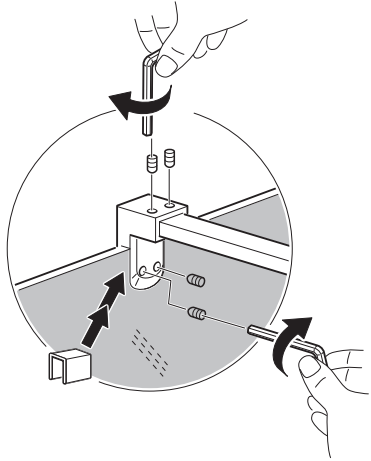
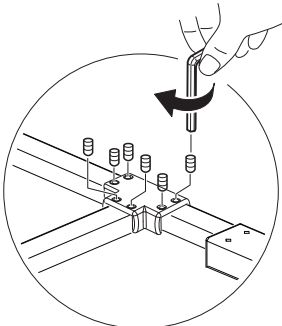
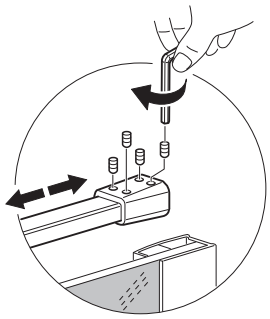
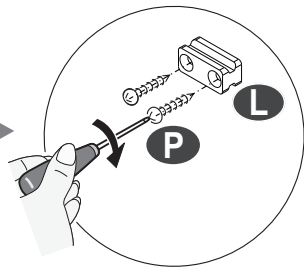
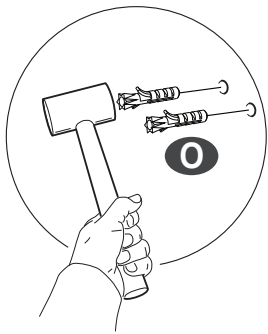

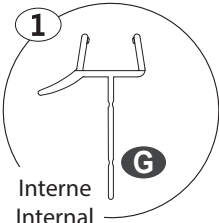
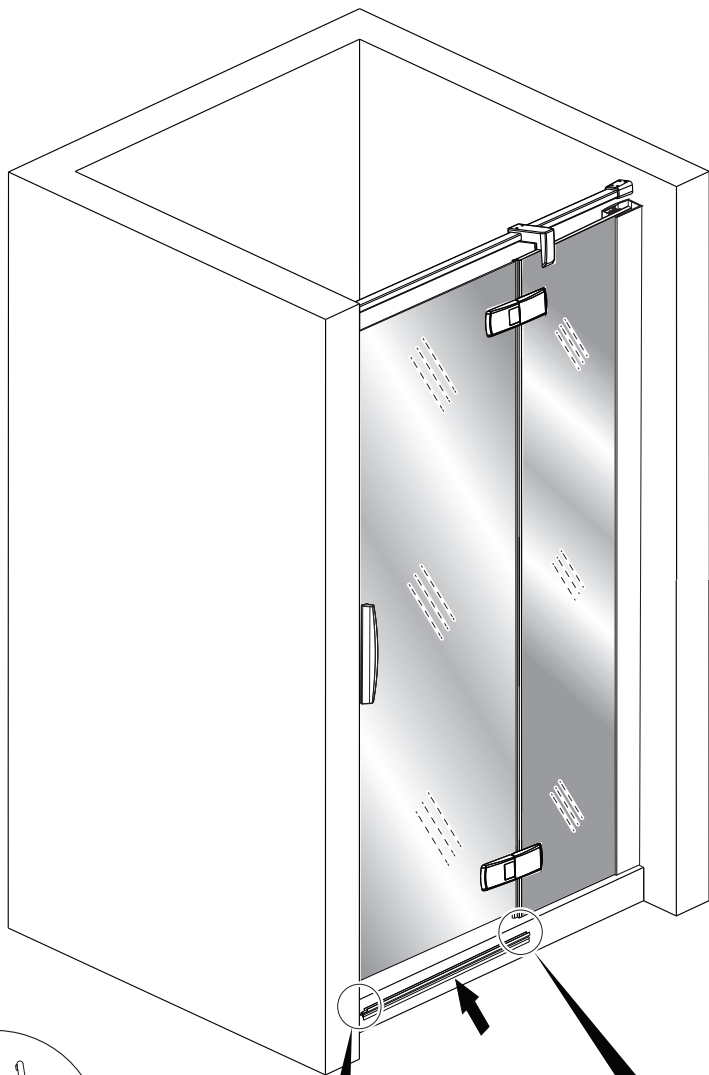

Interne
Internal
Interno
Innen
Interno
Intern

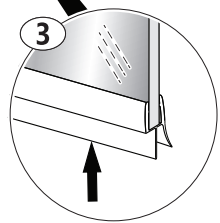
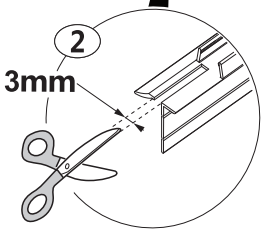

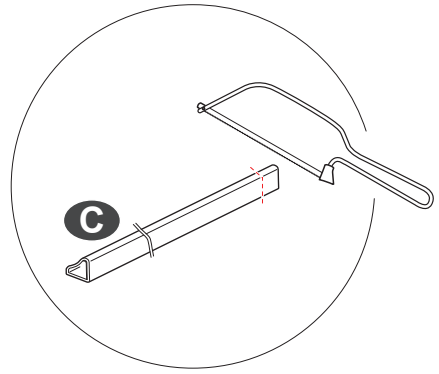
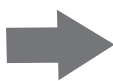
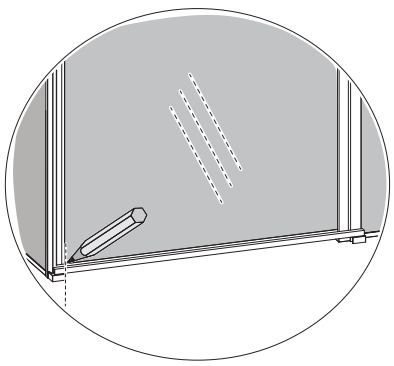
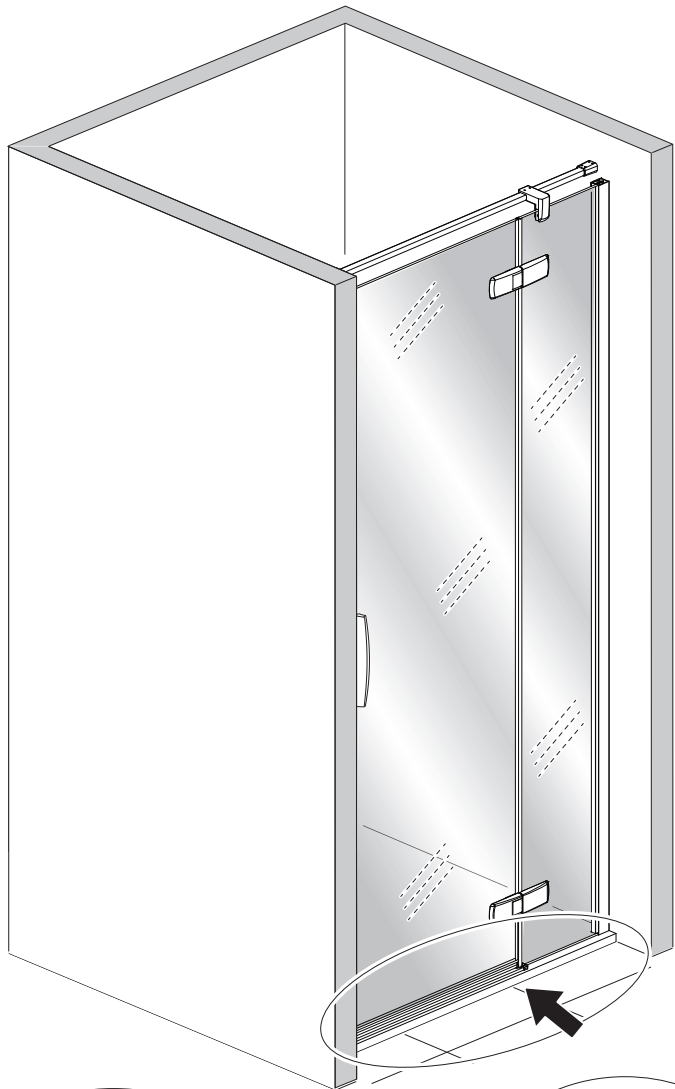

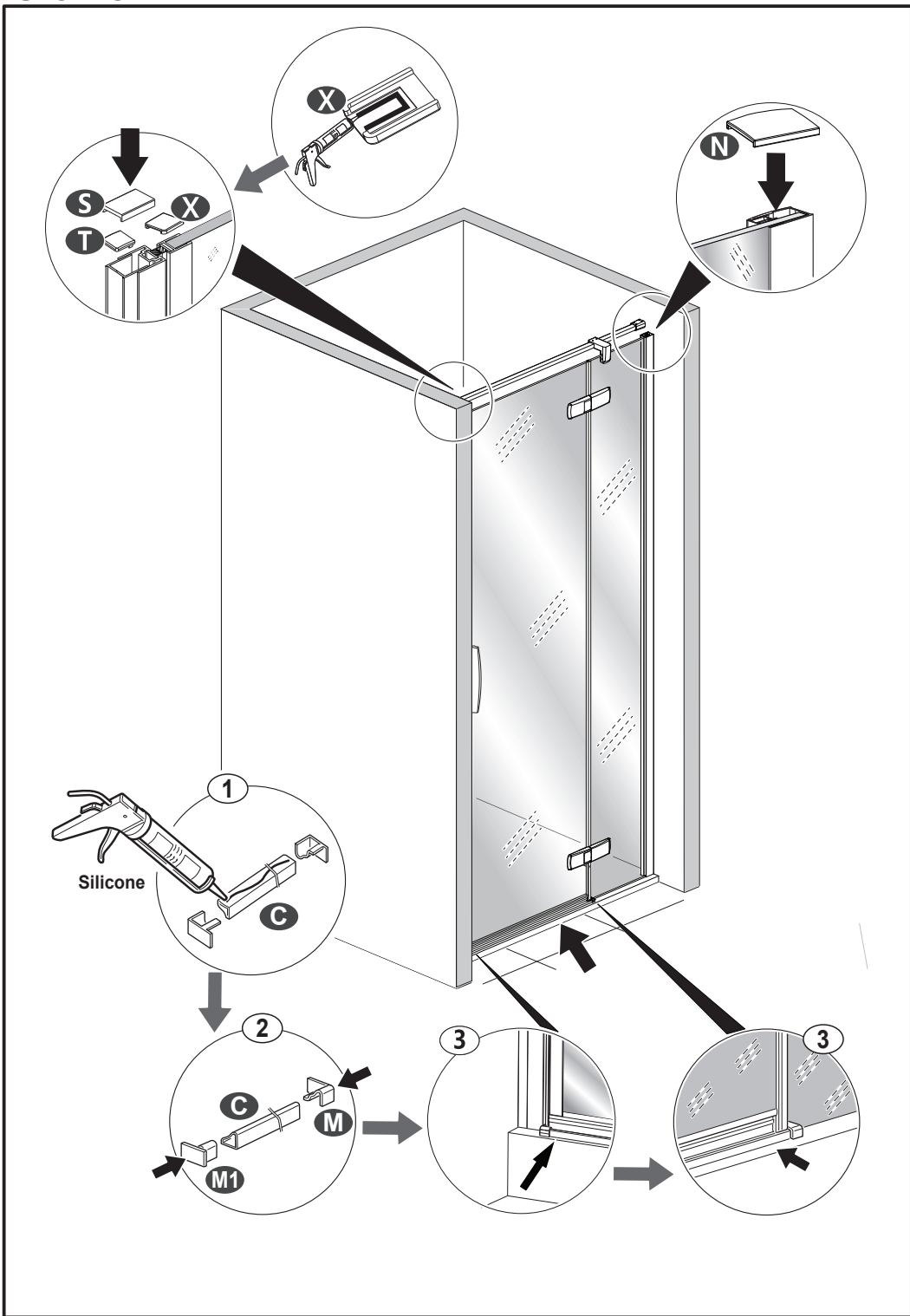

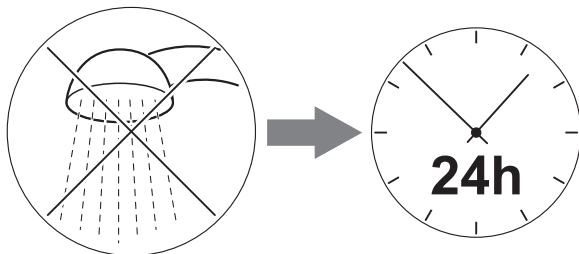
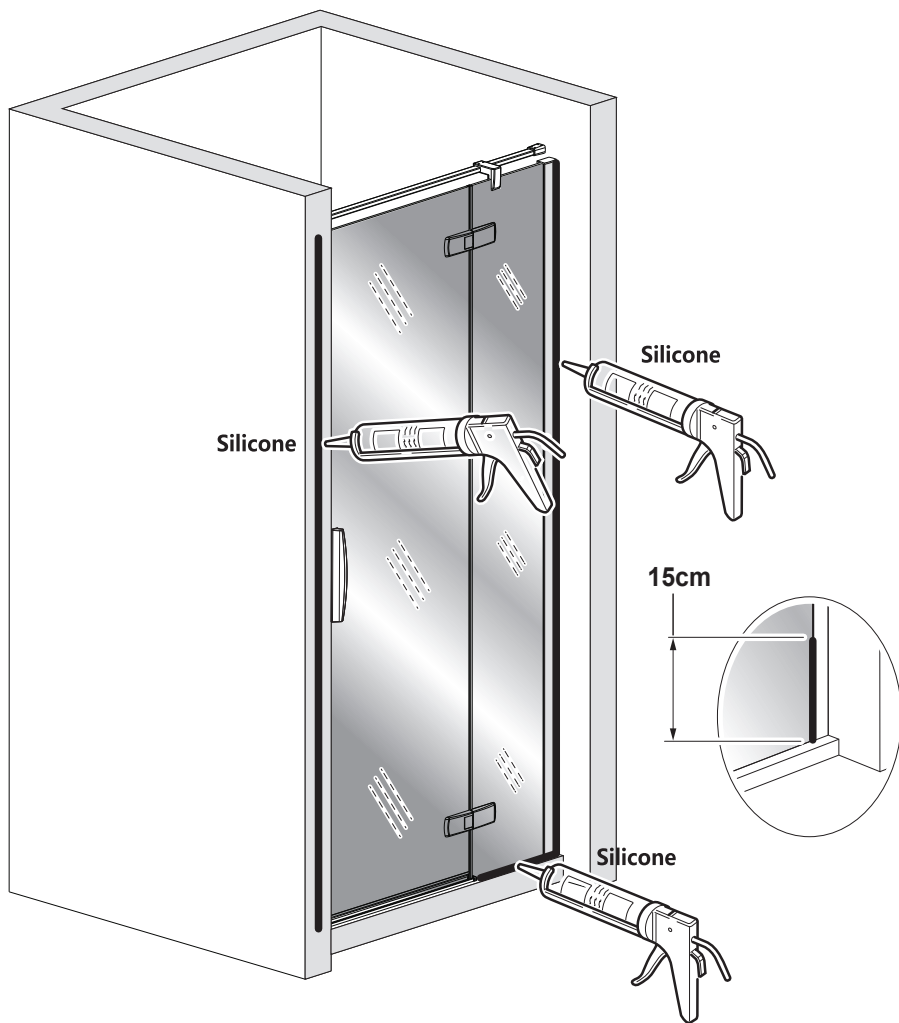

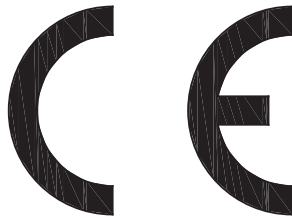

AQUAPRODUCTION, Site industriel,
F - 44680 Chaumes-en-Retz

19

EN 14428

Paroi de douche, fabriquée en verre de silicate
sodo-calcique de sécurité trempé thermiquement

Aptitude au nettoyage : réussite

Résistance à l'impact/propriétés de fragmentation : réussite

Durabilité : réussite



SAV
SERVICE HELPLINES
ASSISTENZA POST-VENDITA
SERVICIO POSTVENTA

FRANCE

02 40 21 29 45

SCHWEIZ

(01) 748 17 44

UK

020 8842 0033

ESPANA

93 544 60 76

IRELAND

04697 33102

NEDERLAND

+31 475 487 100

DEUTSCHLAND

+49 (0) 6074 / 30928 0

BELGIE

+31 475 487 100

ITALIA

(0382) 6181

BELGIQUE

+31 475 487 100

OSTEREICH

+43 1 710 60 70

РОССИЯ

963 19 40, 773 67 22