

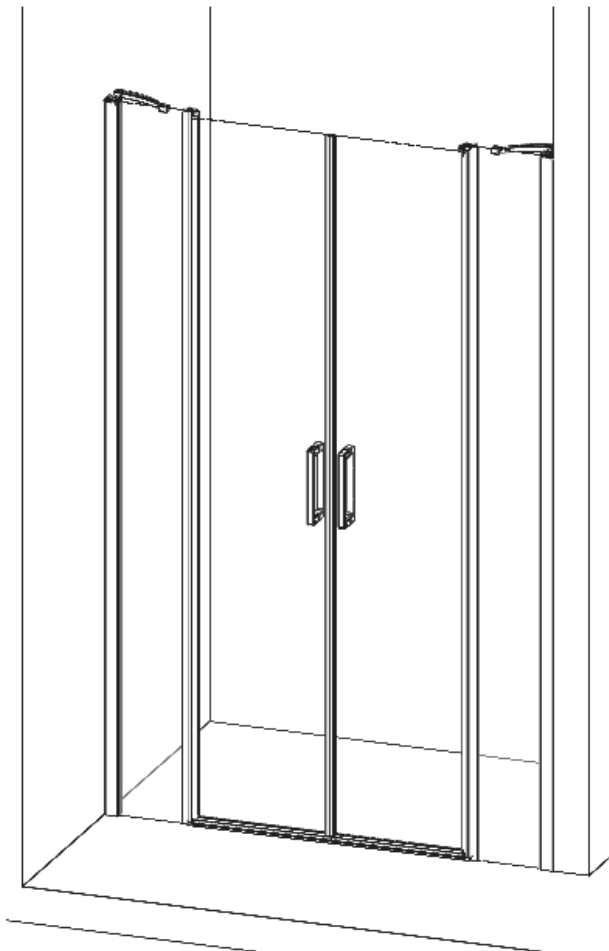

- F NOTICE DE MONTAGE
- GB INSTALLATION INSTRUCTIONS
- I ISTRUZIONI DI MONTAGGIO
- NL INSTALLATIE VOORSCHRIFTEN
- D INSTALLATIONSANLEITUNG







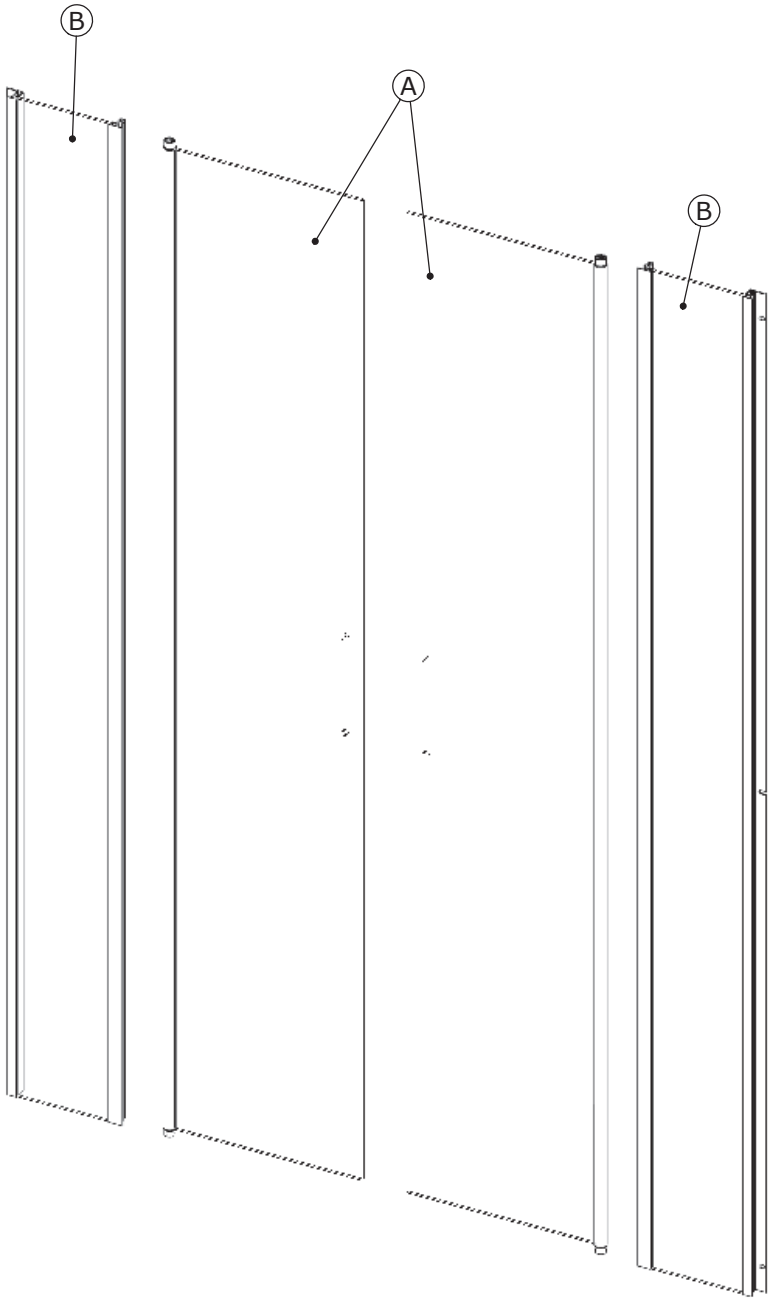

- Attention aux étapes :
- Check installation steps :
- Attenzione ai passi :
- Aandacht voor de stappen :
- Achtung vor den Schritten :

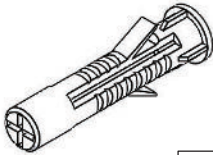
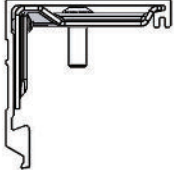
P. 5 - 9 - 25

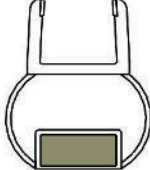
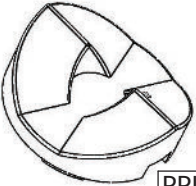
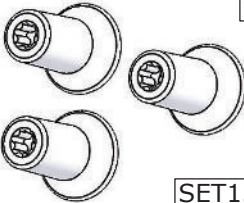
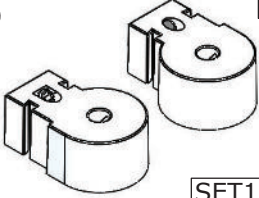
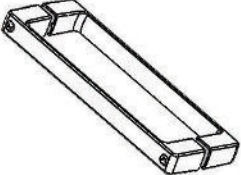
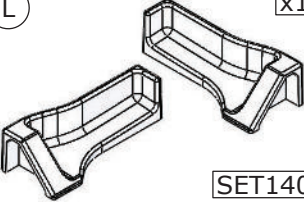
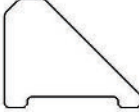
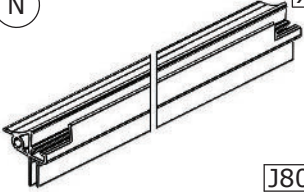
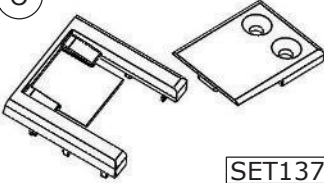
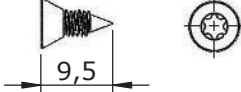
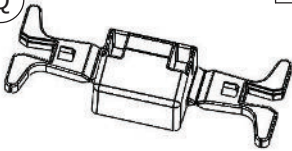

<p>C</p> <p>Ø3.5mm</p> <p>x6</p>  <p>45</p> <p>VIS231</p>	<p>D</p> <p>x6</p>  <p>CHE02</p>	
<p>E</p> <p>x2</p>  <p>Lg= 2000mm</p> <p>6268</p>	<p>F</p> <p>x2</p>  <p>Lg= 2000mm</p> <p>6270</p>	<p>G</p> <p>x2</p>  <p>Lg= 1962mm</p> <p>AI178</p>
<p>H</p> <p>x2</p>  <p>PPL1248</p>	<p>I</p> <p>x2</p>  <p>SET134</p>	<p>J</p> <p>x2</p>  <p>SET128</p>
<p>K</p> <p>x2</p>  <p>PGN49</p>	<p>L</p> <p>x1</p>  <p>SET140</p>	<p>M</p> <p>x2</p>  <p>6285</p>
<p>N</p> <p>x1</p>  <p>J806</p>	<p>O</p> <p>x2</p>  <p>SET137</p>	<p>P</p> <p>Ø3.5mm</p> <p>x2</p>  <p>9,5</p> <p>VIS261</p>
<p>Q</p> <p>x4</p>  <p>PPL1339</p>	<p>R</p> <p>x1</p>  <p>SUP129</p>	<p>S</p> <p>x1</p>  <p>SUP130</p>

- Les quantités données sont les quantités utiles au montage. les sachets fournis contiennent des pièces supplémentaires.
  - The quantities given are what are required for the installation. There may be some surplus in the package provide.
    - Le quantità fornite sono le quantità necessarie al montaggio. I sacchetti forniti contengono pezzi supplementari.
    - De aangegeven aantallen zijn vereist voor de montage. De verpakking bevat extra onderdelen.
- Die Mengenangaben beziehen sich auf die für die Montage nötigen Teile. Eventuell weitere beige-packte Teile ignorieren.

● Matériel nécessaire ● Tools required  
 ● Materiale necessario ● Benodigd gereedschap ● Benötigte Werkzeuge

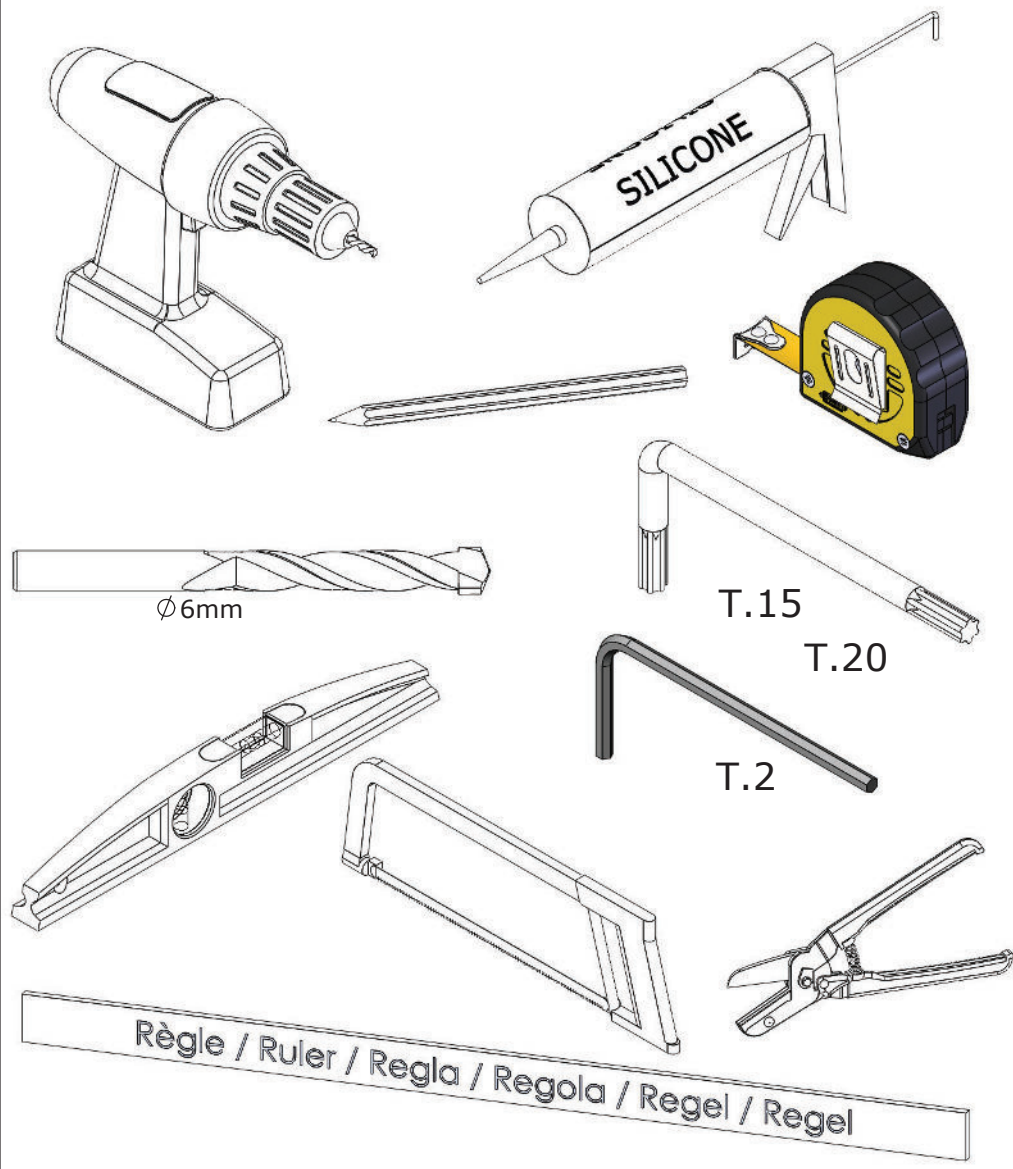

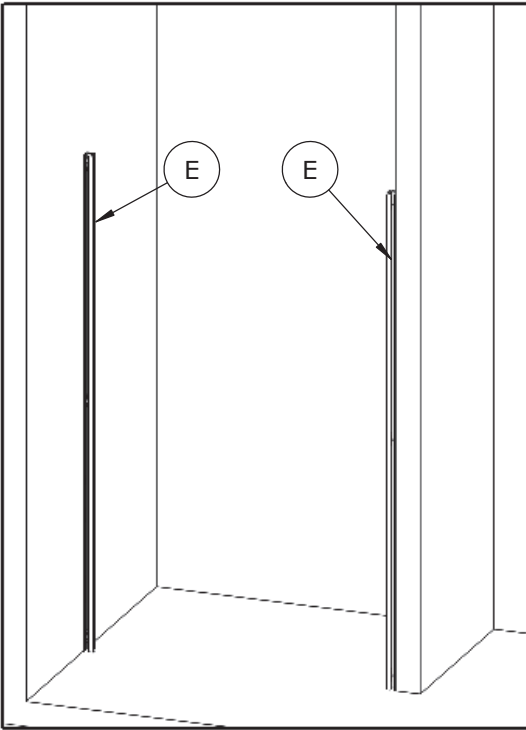

- F Si receveur
- GB If shower tray
- I Se piatto
- NL Als douchebak
- D Wenn Duschanne

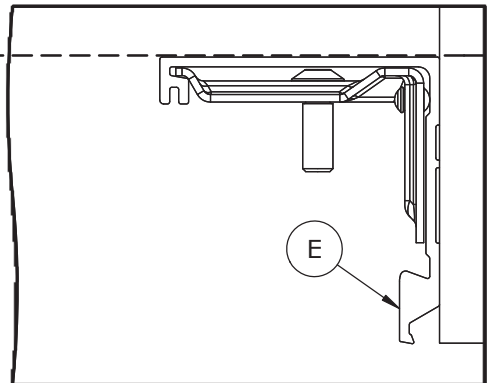
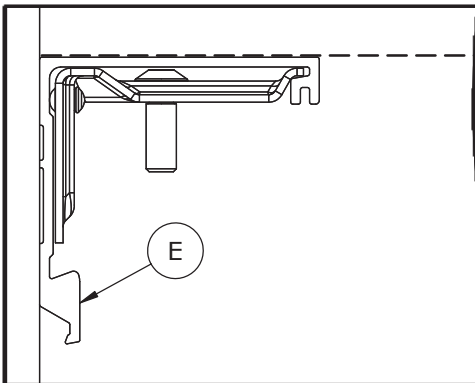
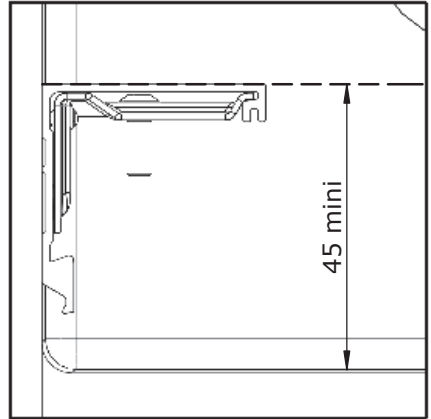

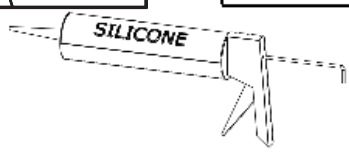
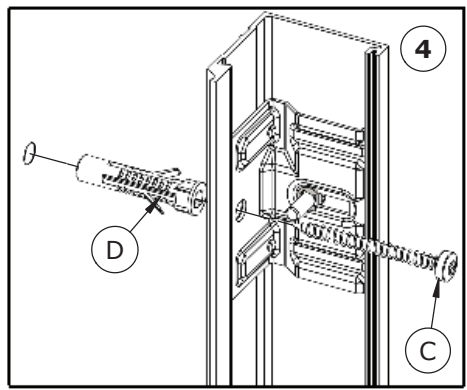
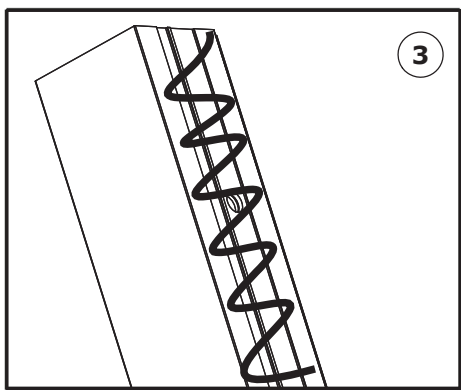
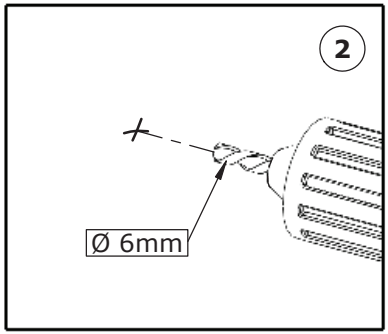
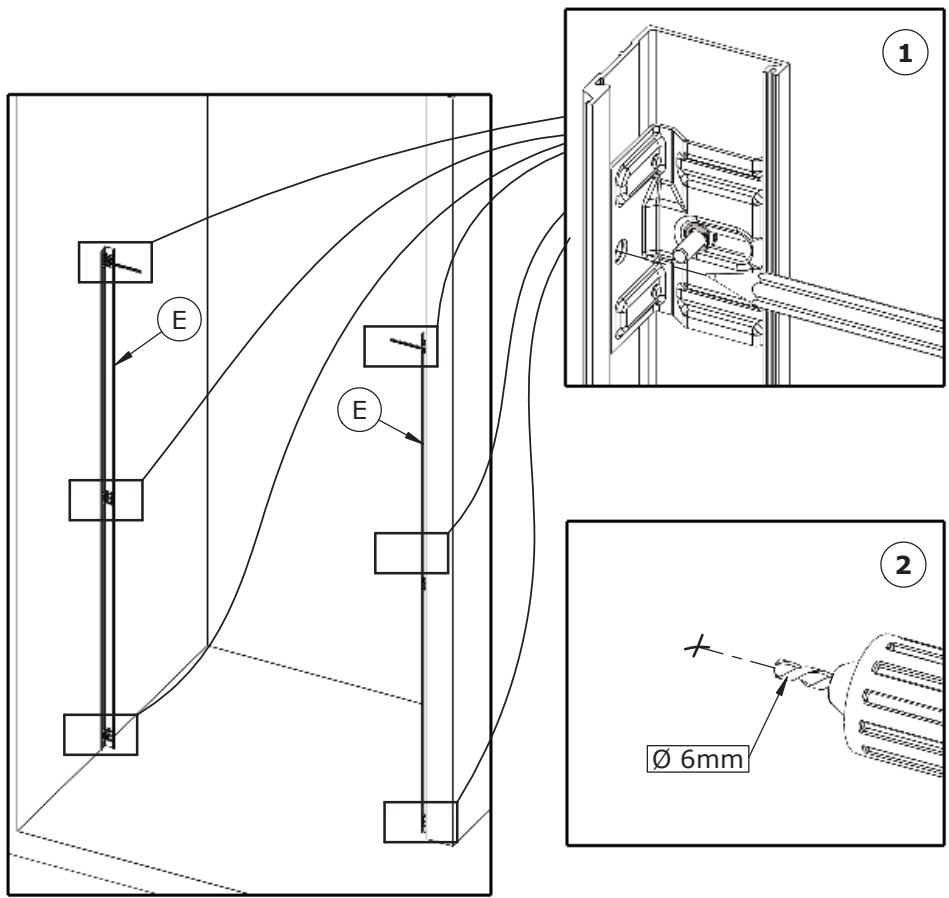

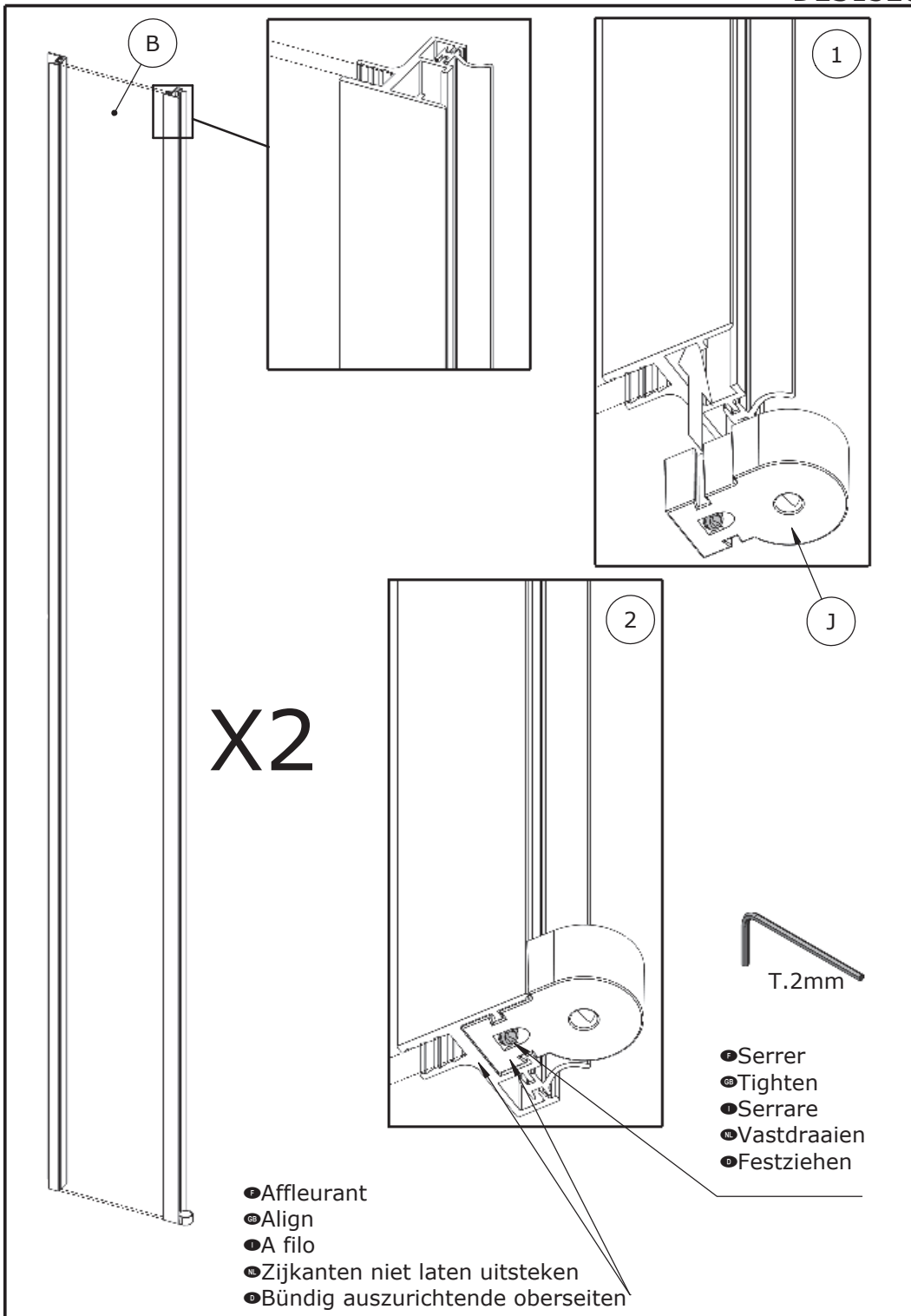

X4



I

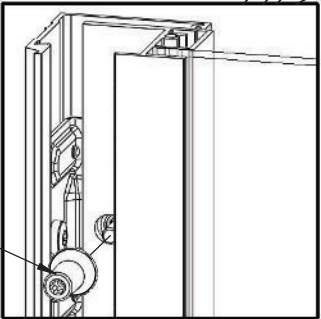
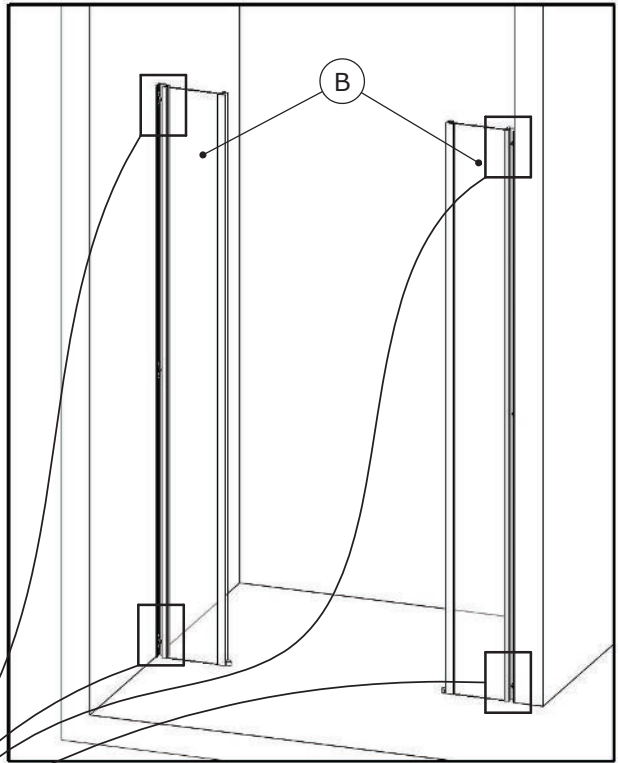

I

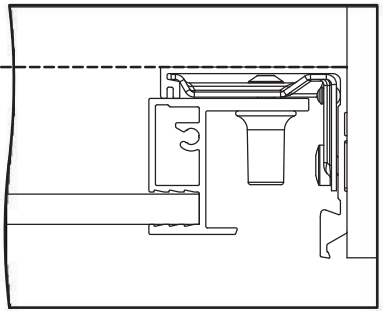
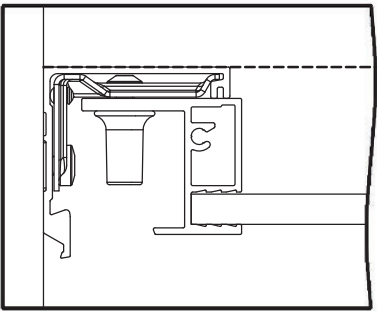
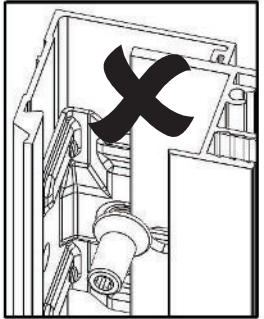
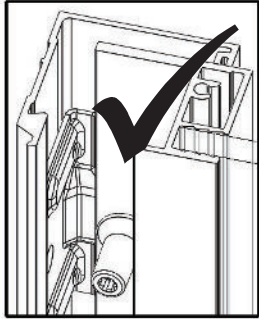



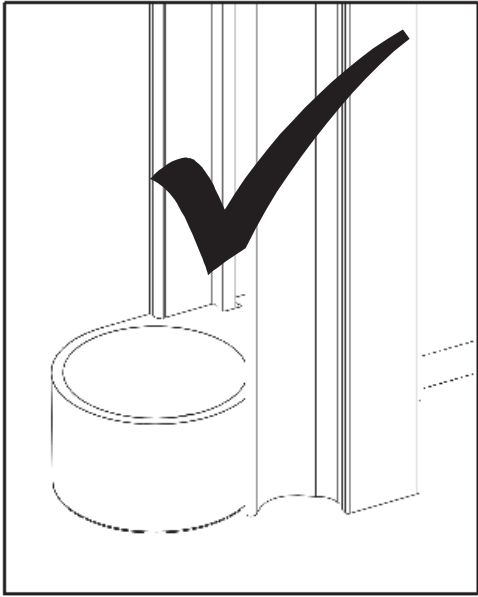
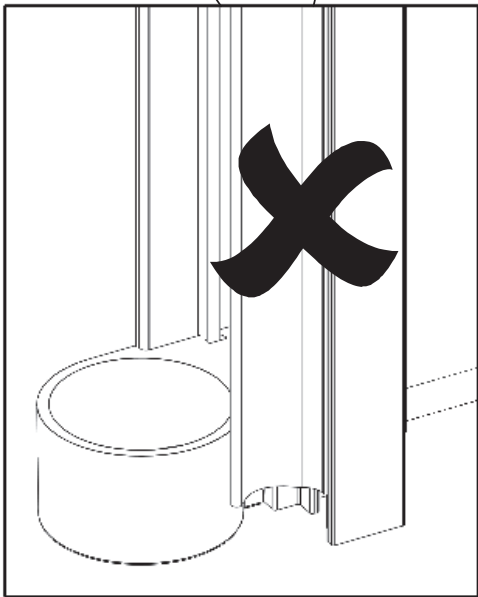
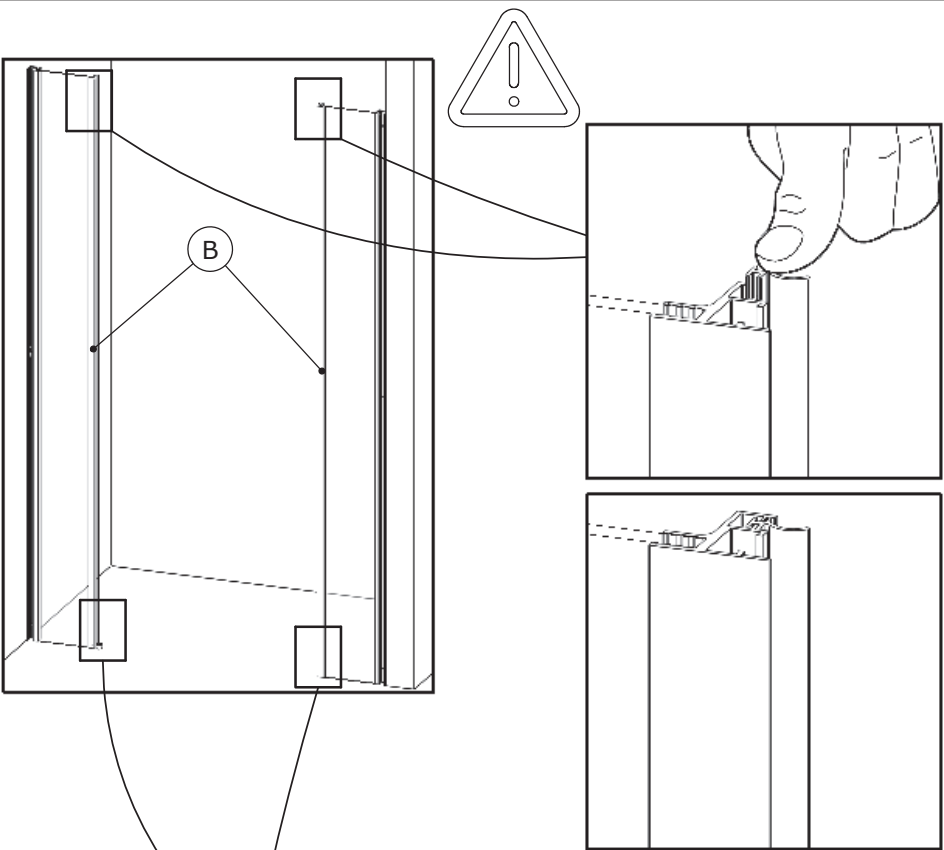

- Réglages des portes ● Adjusting the doors ● regolazione porte
- Deuren afstellen ● Ausrichten und Einstellen der Tür

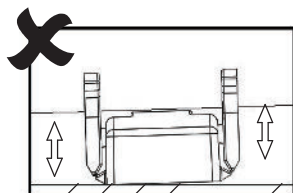
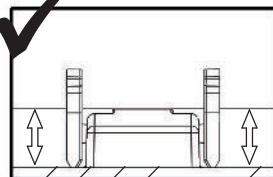
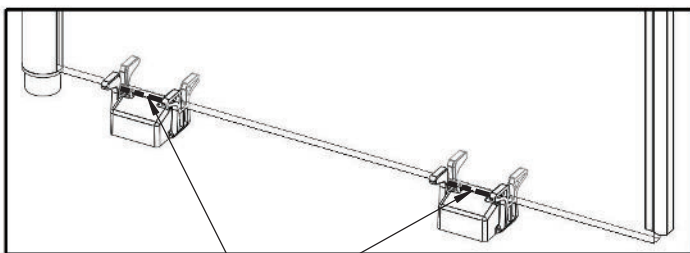
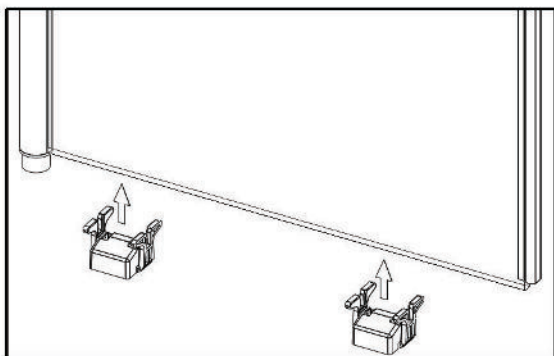
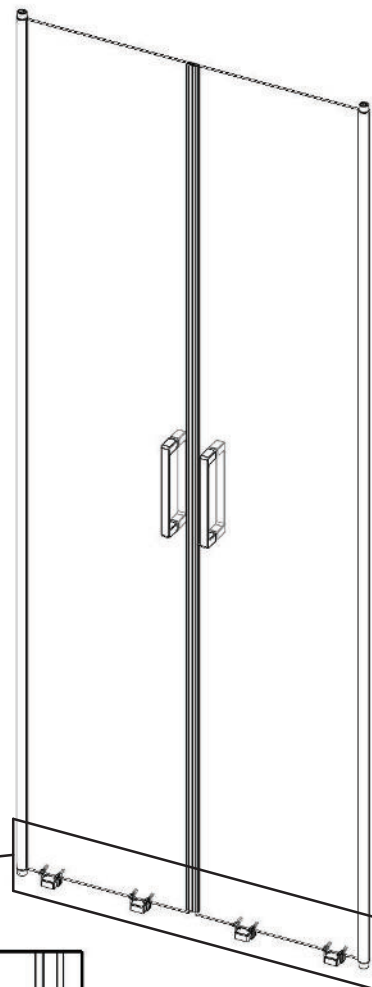
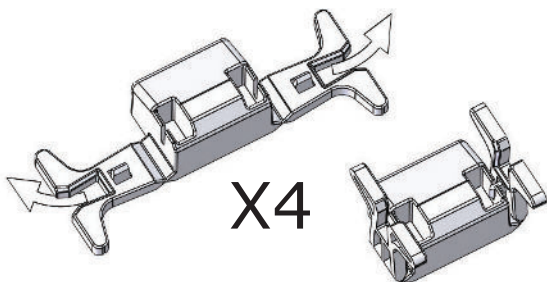

- Mettre en contact
- Put in contact
- Mettere in contatto
- Mensen in contact te brengen
- Kontakte knüpfen

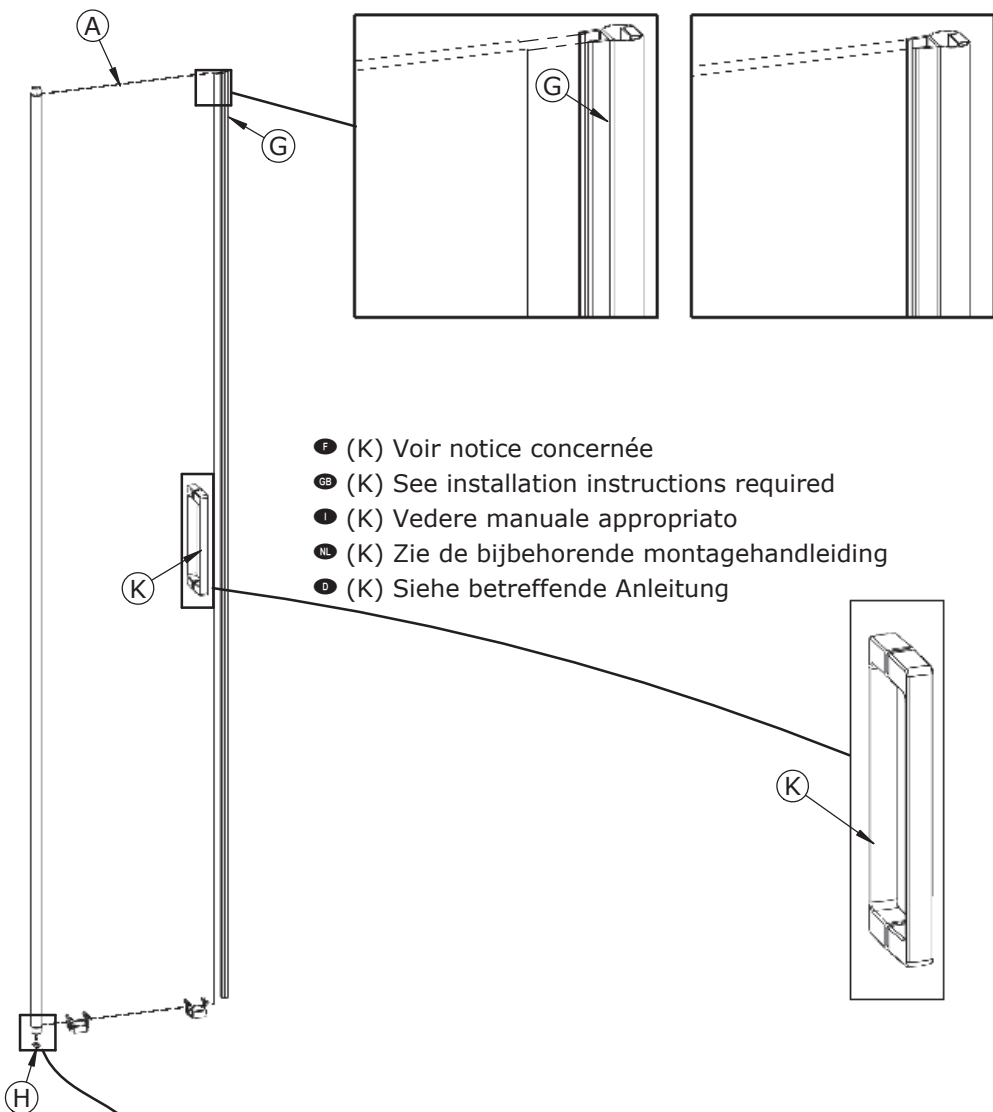

- <sub>F</sub> (K) Voir notice concernée
- <sub>GB</sub> (K) See installation instructions required
- (K) Vedere manuale appropriato
- <sub>NL</sub> (K) Zie de bijbehorende montagehandleiding
- <sub>D</sub> (K) Siehe betreffende Anleitung

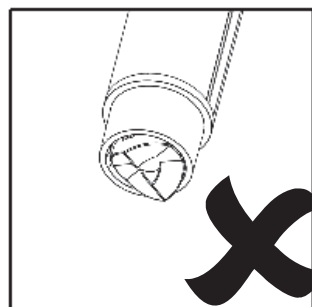
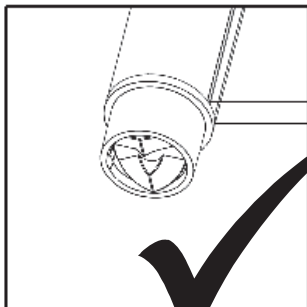
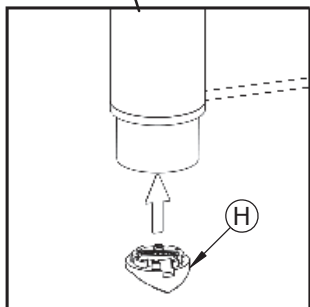

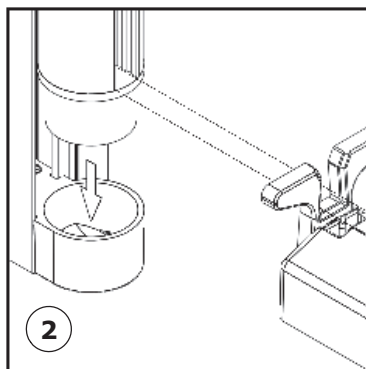
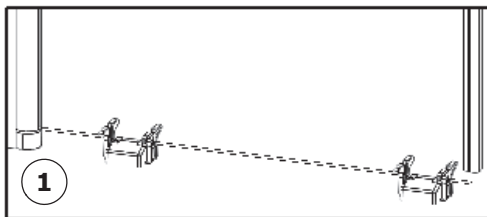
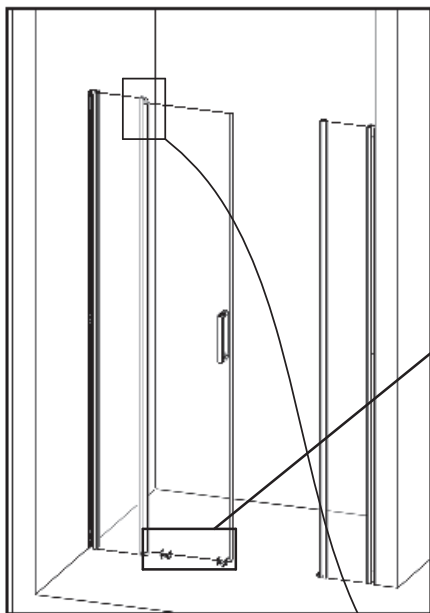

- Affleurant ● Flush
- Affioramento
- Doorspelen ● Bündig

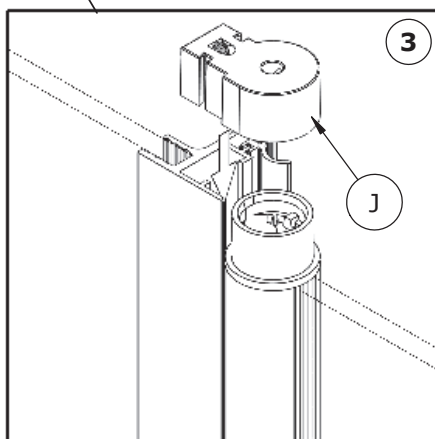
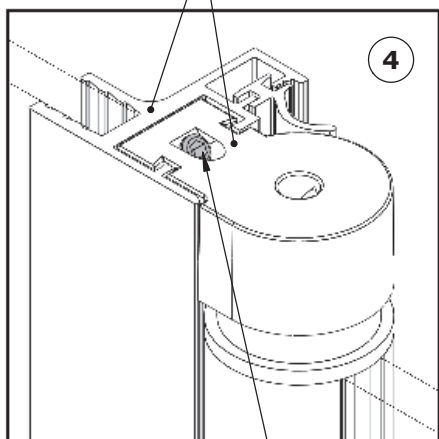

- Serrer ● Tighten
- Serrare
- Vastdraaien ● Festziehen

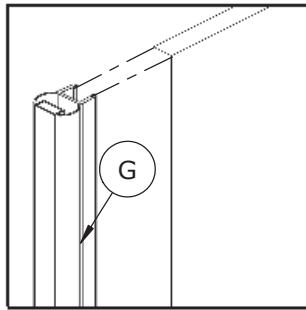
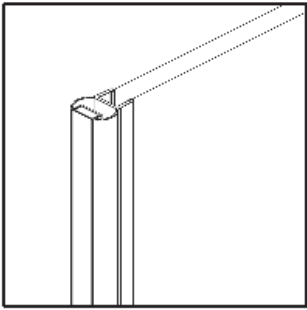

G

- **F** (K) Voir notice concernée
- **GB** (K) See installation instructions required
- **I** (K) Vedere manuale appropriato
- **NL** (K) Zie de bijbehorende montagehandleiding
- **D** (K) Siehe betreffende Anleitung

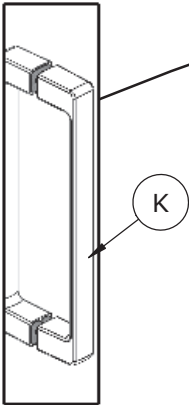

K

H

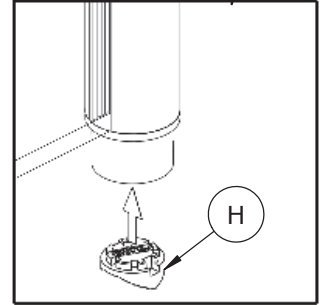
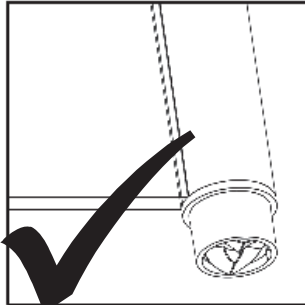
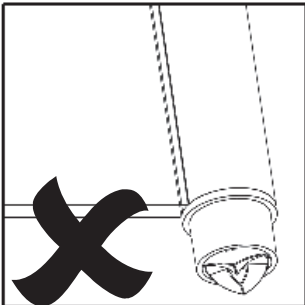

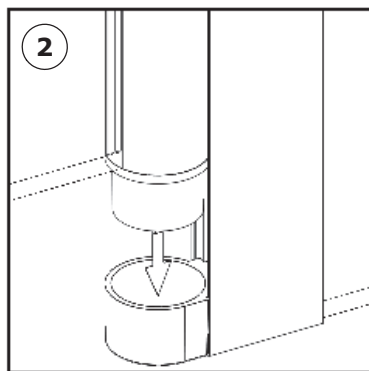
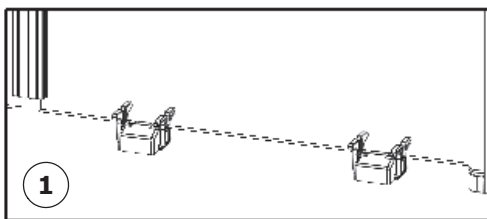
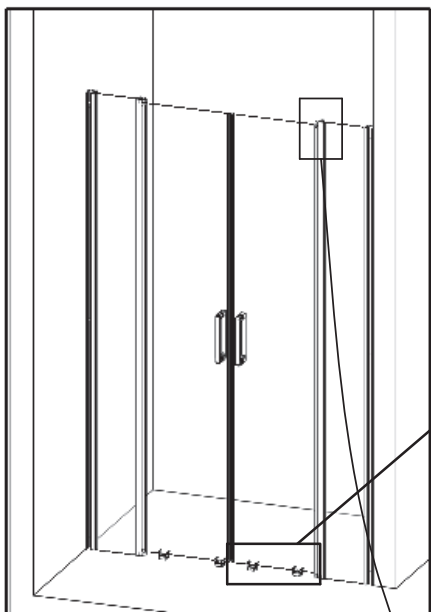

- Affleurant ● Flush
- Affioramento
- Doorspoelen ● Bündig

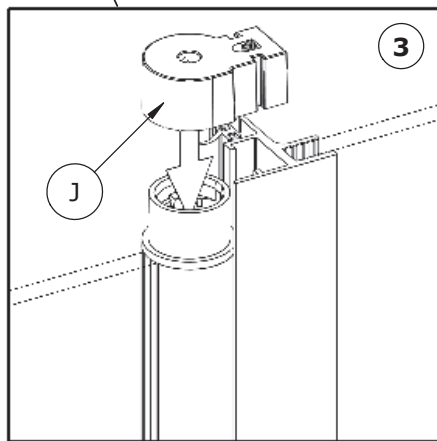
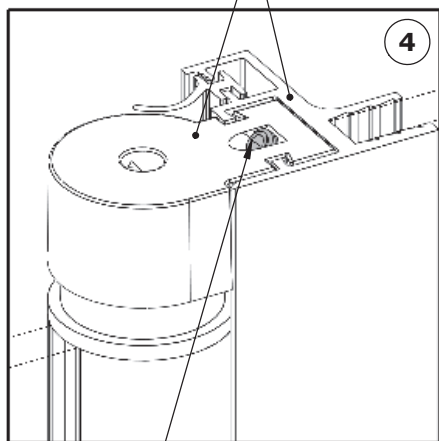

- Serrer ● Tighten
- Serrare
- Vastdraaien ● Festziehen

- Si nécessaire, desserrer, régler puis resserrer
- If necessary, loosen, adjust and retighten
- Se necessario, allentare, regolare e stringere
- Draai los, indien nodig, stel af en draai vervolgens weer vast
- Falls erforderlich, lösen, einstellen und wieder festziehen

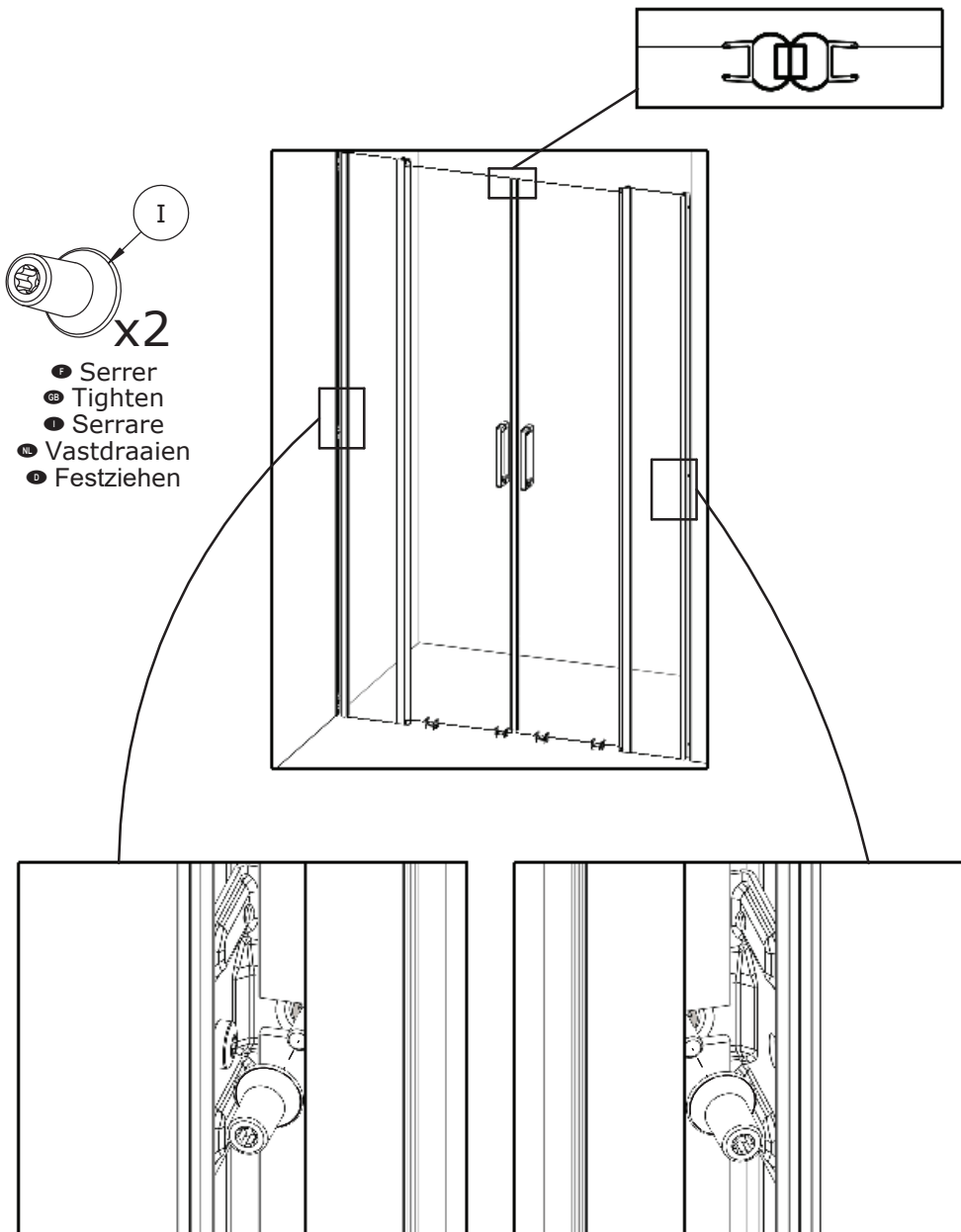

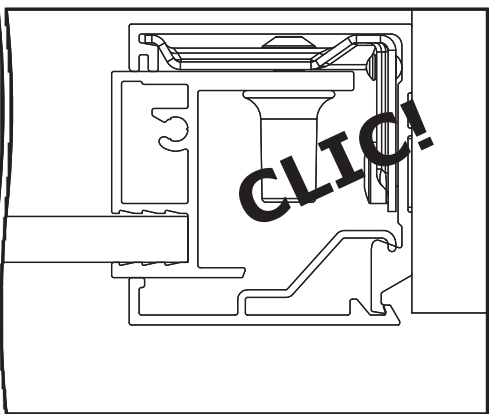
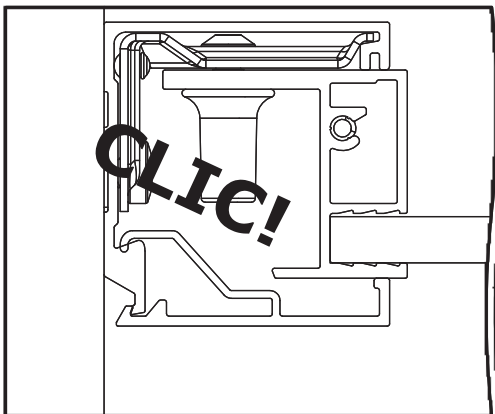
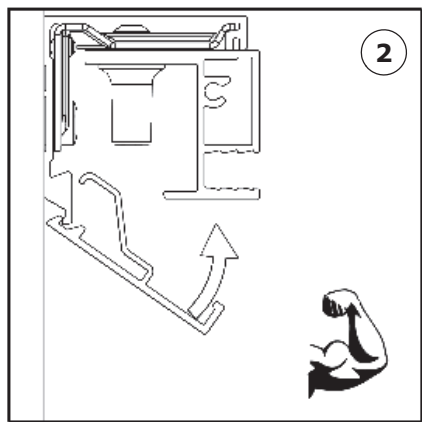
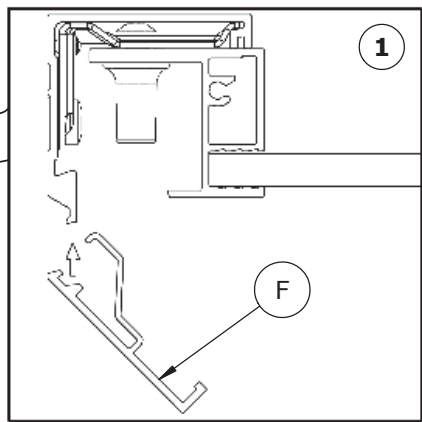
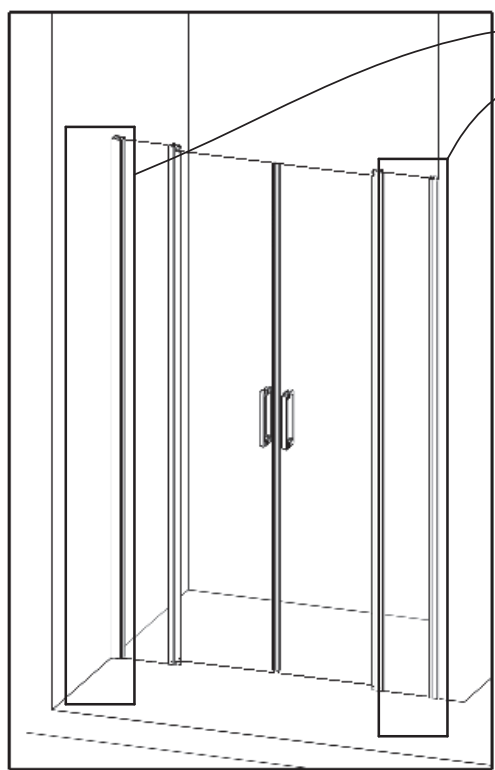



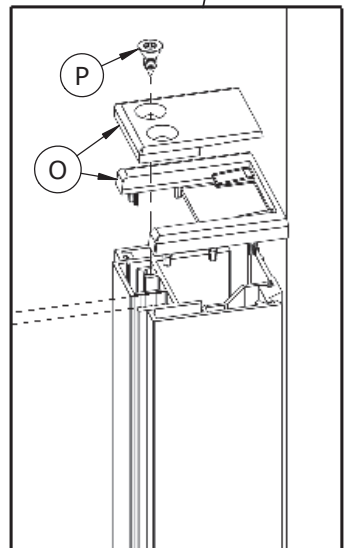
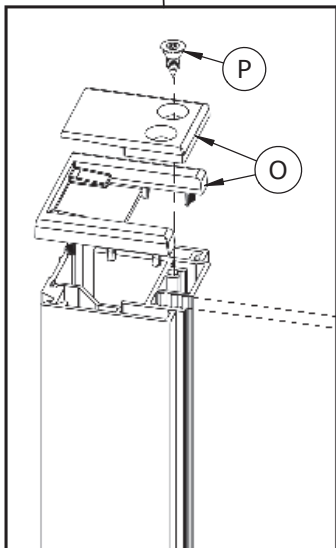
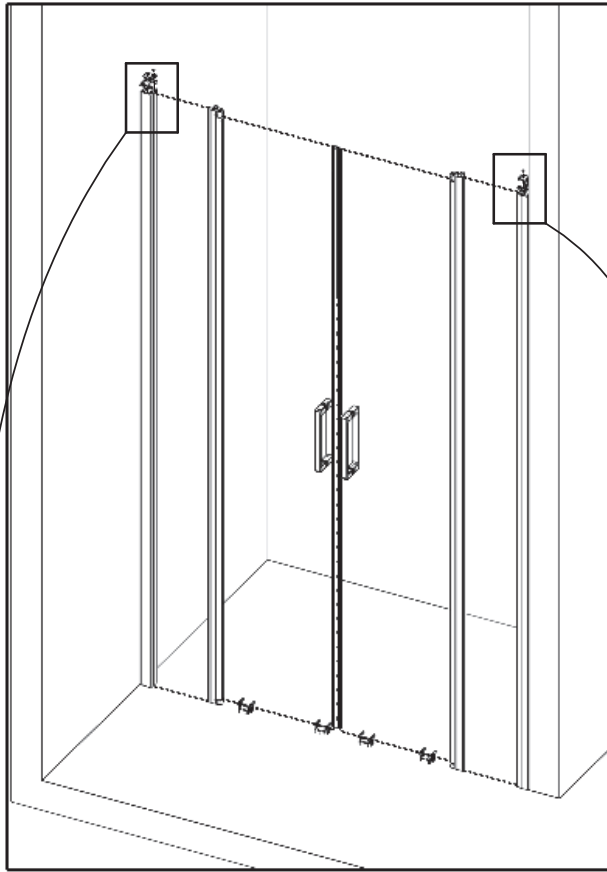

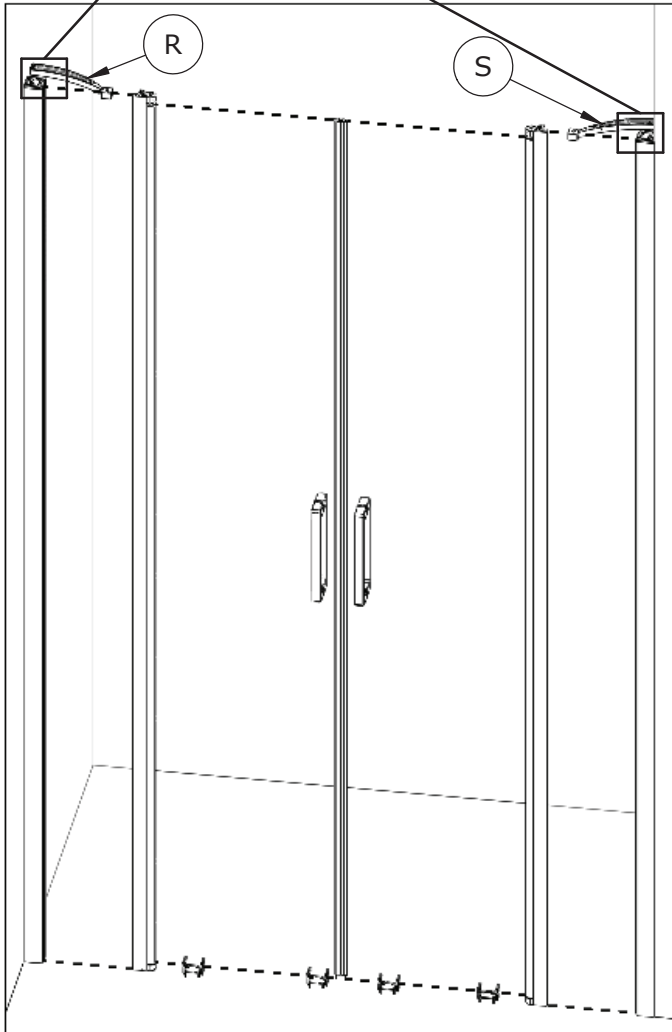
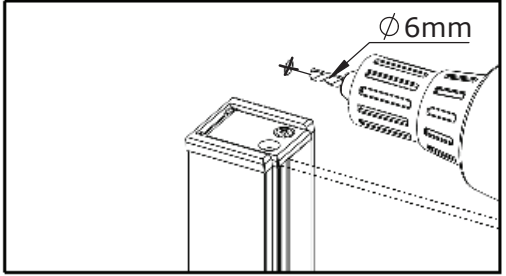
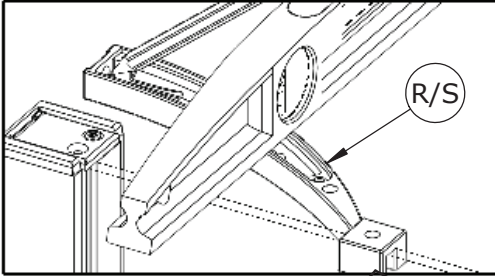

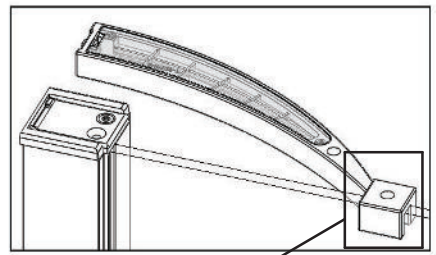
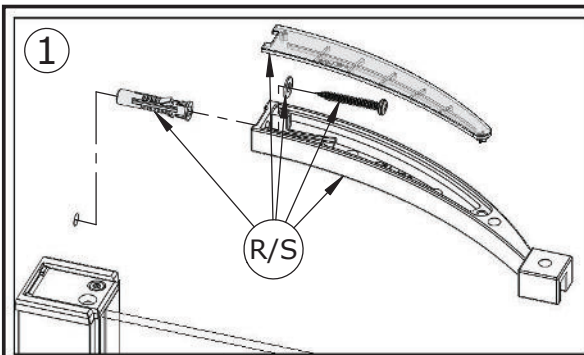

- EXTERIEUR
- Exterior
- Esterno
- Buitenkant
- Außen

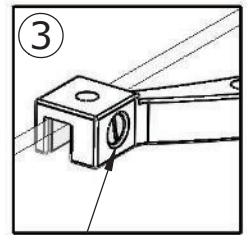
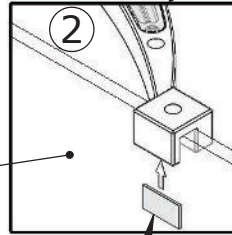

R/S

- Serrer
- Tighten
- Serrare
- Vastdraaien
- Festziehen



- Retirer (Q) ● Remove (Q) ● Togliere (Q)
- Verwijderen (Q) ● Entfernen (Q)

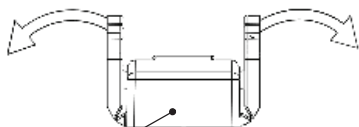

Q

X4

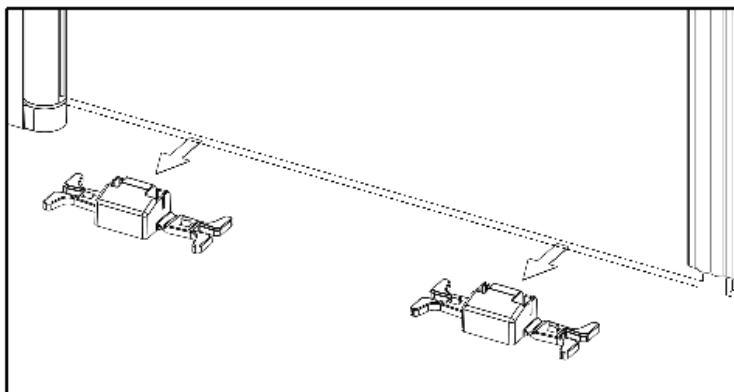
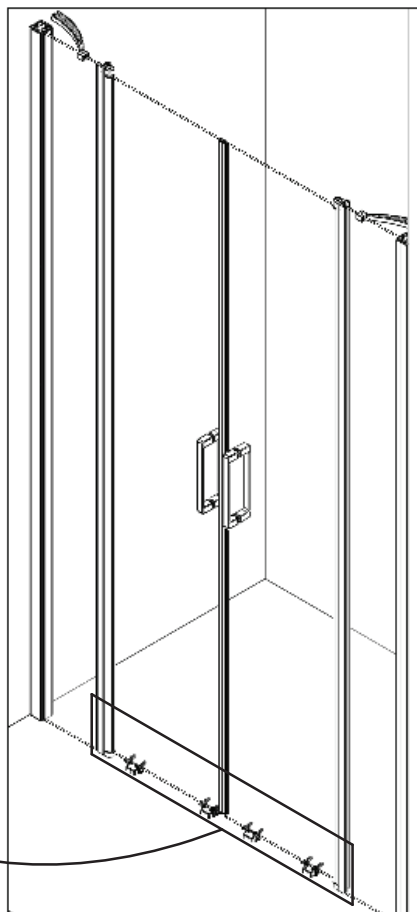
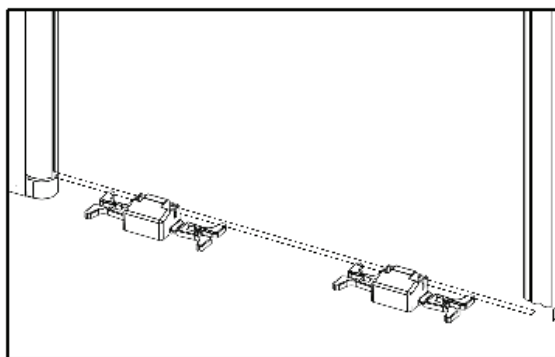

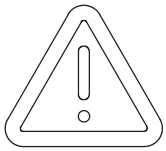

(I) Intérieur (EN) Inside  
 (I) Interno  
 (NL) Binnenkant (D) Innen

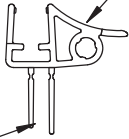

(N)

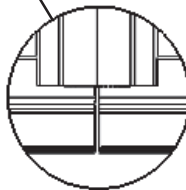
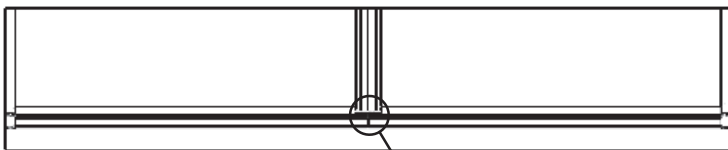
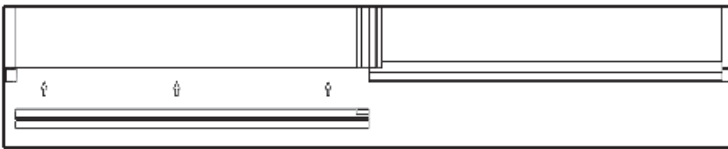
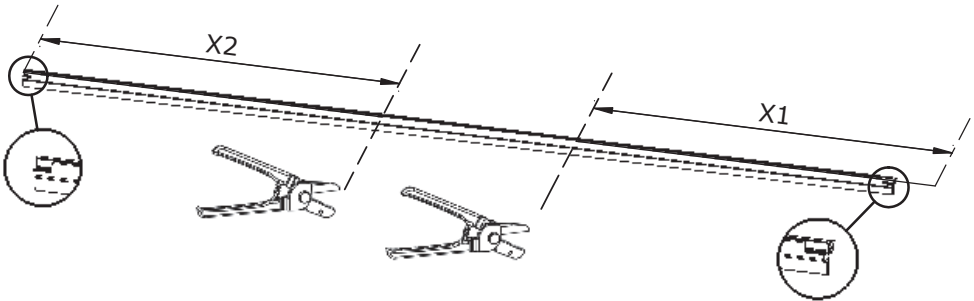
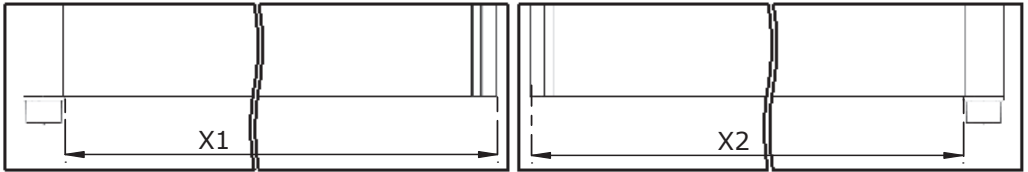
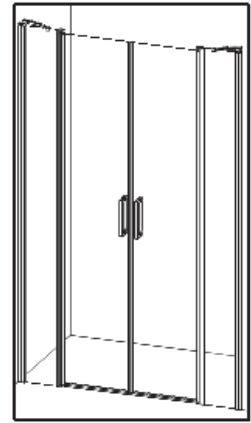

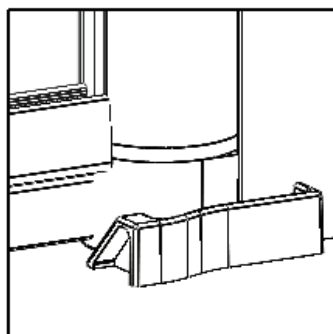
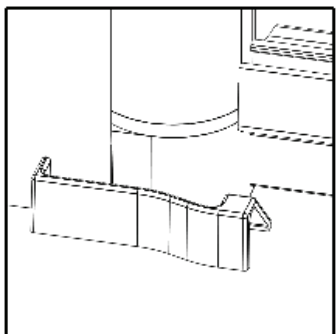
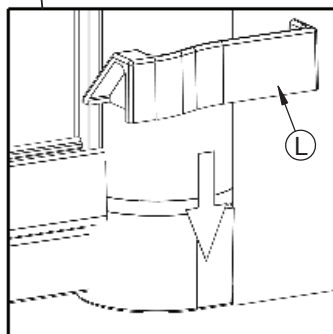
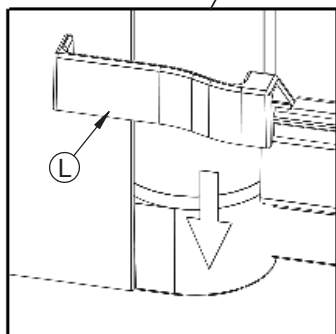
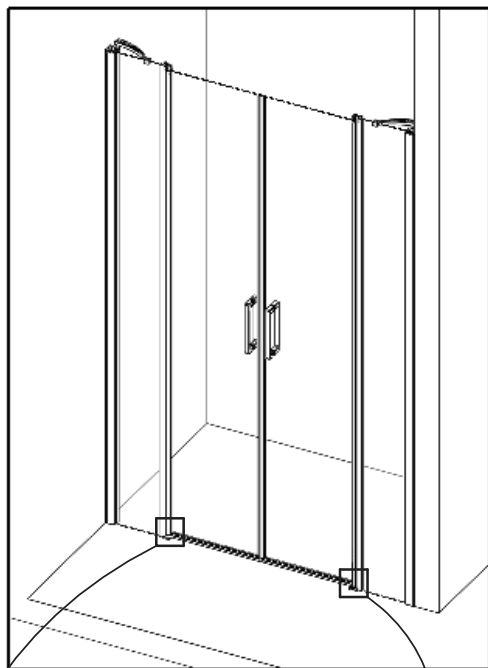

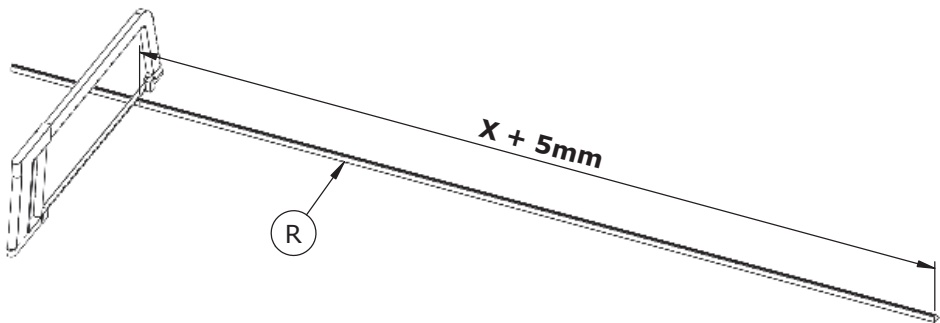
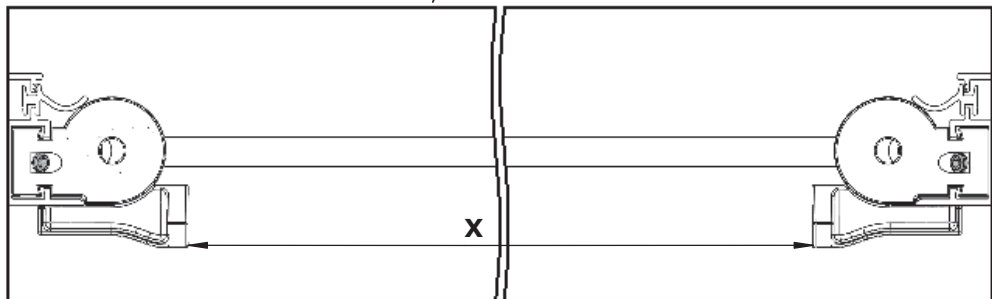
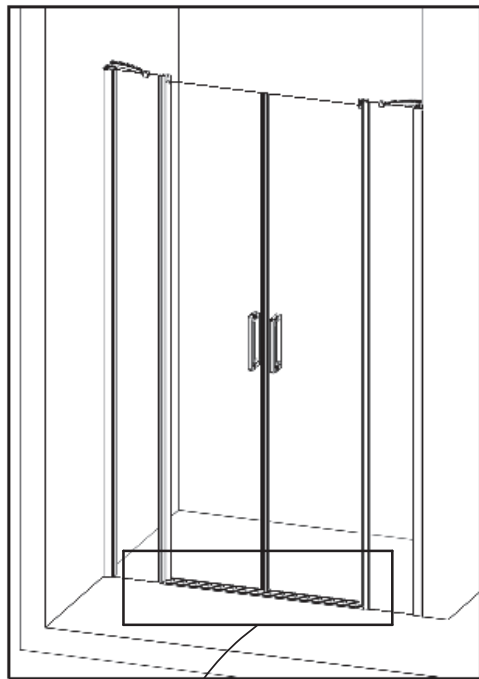

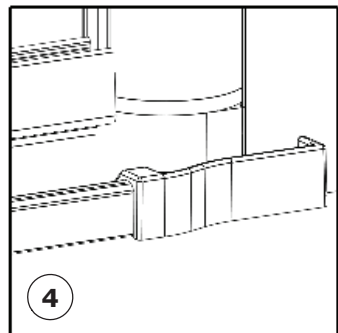
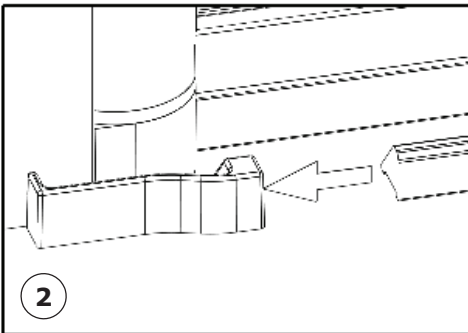
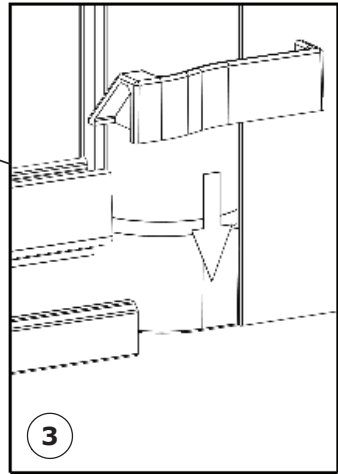
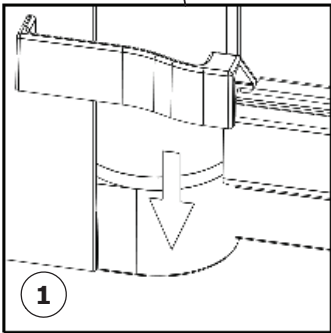
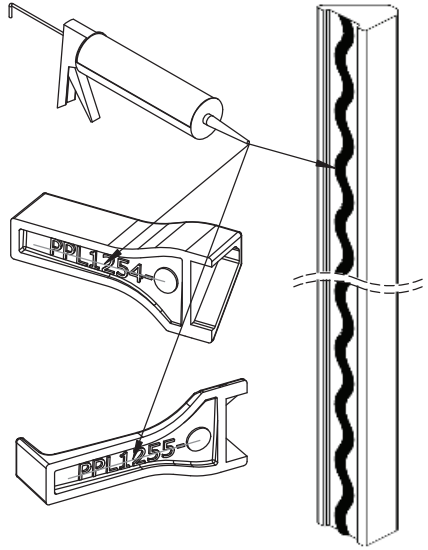
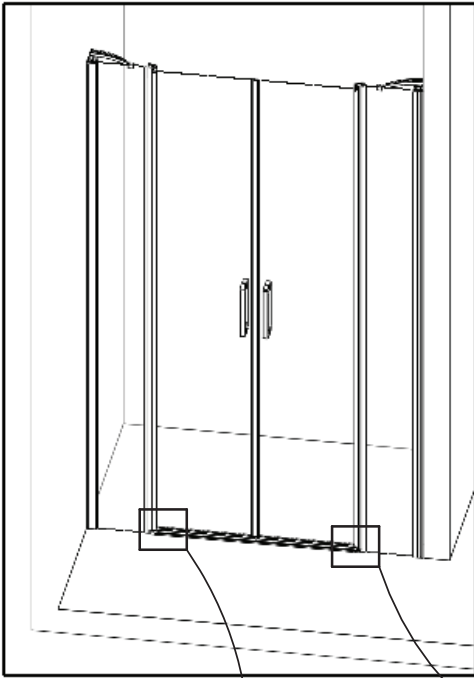



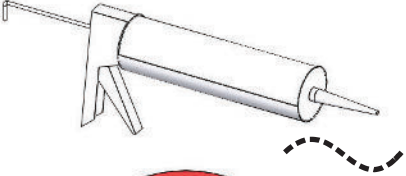

24H

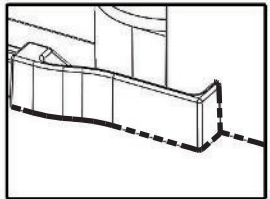
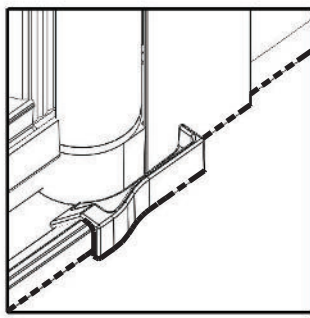
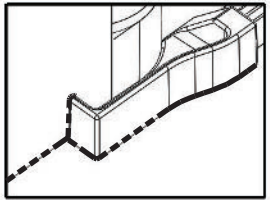
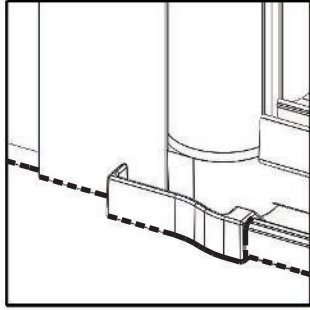
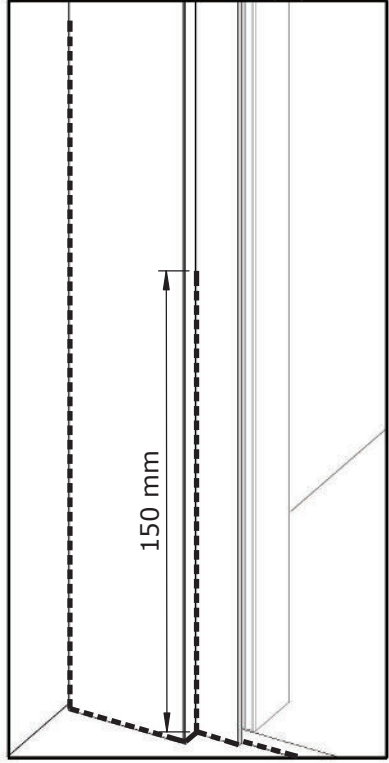
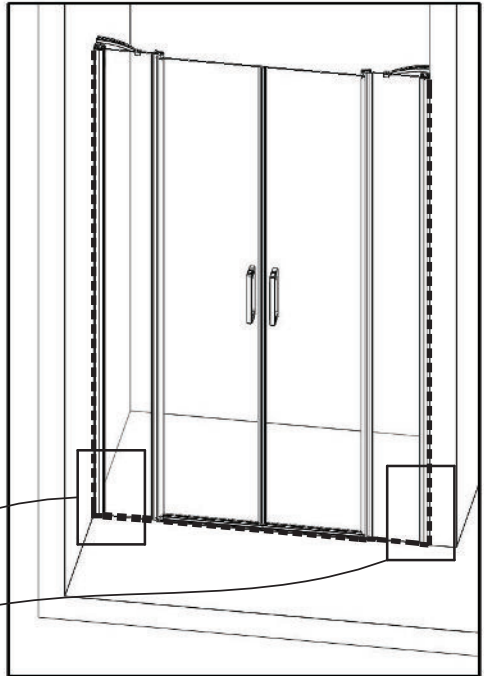





AQUAPRODUCTION, Site industriel,  
F - 44680 Chaumes-en-Retz

18

**EN 14428**

Paroi de douche, fabriquée en verre de silicate  
sodo-calcique de sécurité trempé thermiquement

Aptitude au nettoyage : réussite

Résistance à l'impact/propriétés de fragmentation : réussite

Durabilité : réussite



**SAV**  
**SERVICE HELPLINES**  
**ASSISTENZA POST-VENDITA**  
**SERVICIO POSTVENTA**

**FRANCE**

02 40 21 29 45

**SCHWEIZ**

(01) 748 17 44

**UK**

020 8842 0033

**ESPANA**

93 544 60 76

**IRELAND**

04697 33102

**NEDERLAND**

+31 475 487 100

**DEUTSCHLAND**

+49 (0) 6074 / 30928 0

**BELGIE**

+31 475 487 100

**ITALIA**

(0382) 6181

**BELGIQUE**

+31 475 487 100

**OSTEREICH**

+43 1 710 60 70

**РОССИЯ**

963 19 40, 773 67 22