

- F Notice de montage ● GB Installation instructions
- E Manual de instalación ● I Istruzioni di montaggio
- NL Montage-instructies ● D Montageanleitung

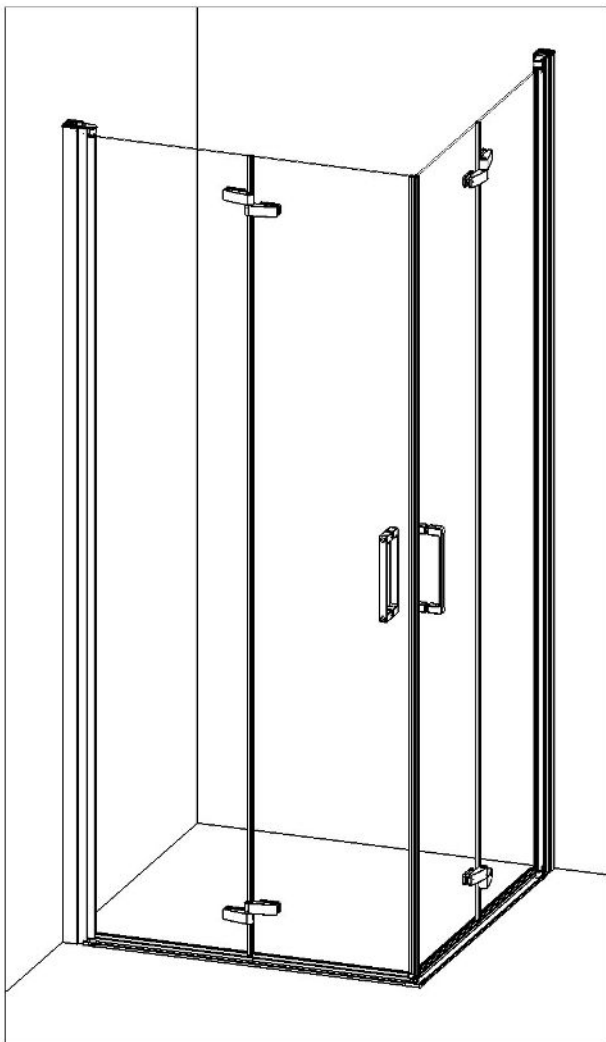





Notre service technique est à votre écoute aux numéros qui sont au dos de cette notice d'installation

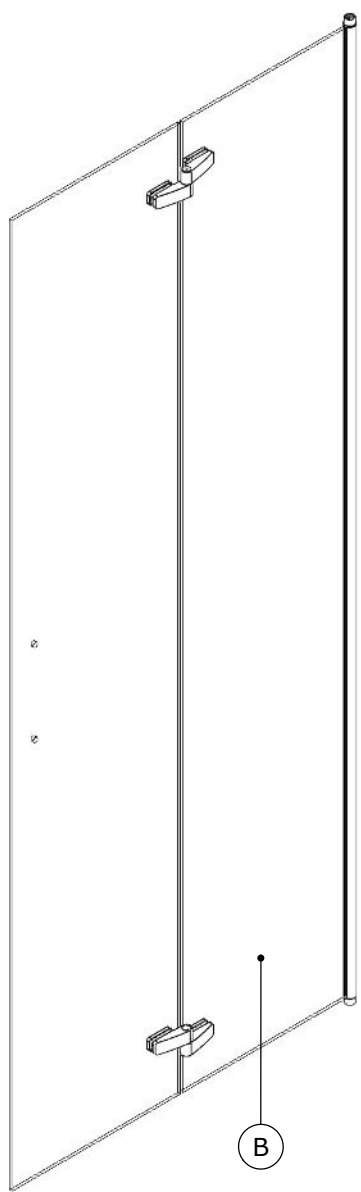
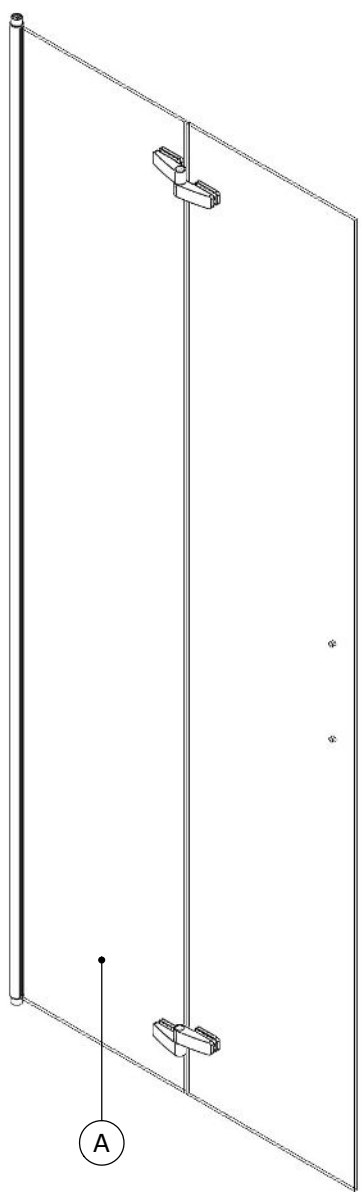

- Attention aux étapes :
- GB Check installation steps :
- E Atención a los pasos :
- I Attenzione ai passi :
- NL Aandacht voor de stappen :
- D Achtung vor den Schritten :

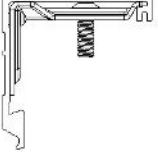
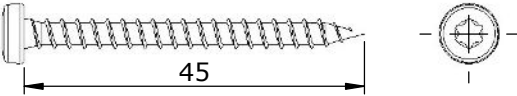
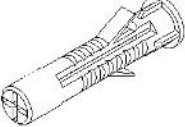
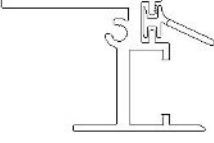
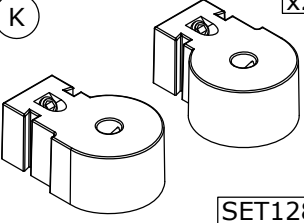
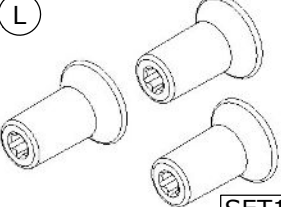
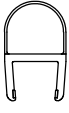
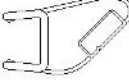
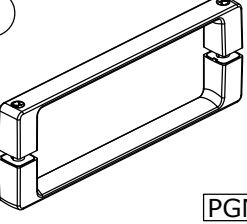
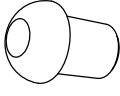
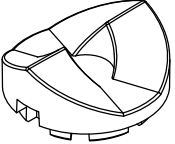
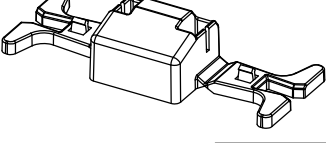
P. 6 - 24 - 37

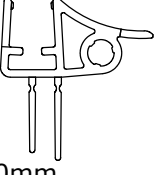
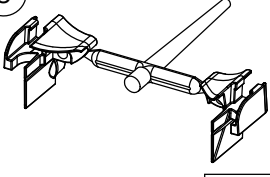
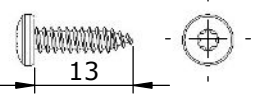

<p>G x2</p>  <p style="text-align: right;">6268</p>	<p>H Ø4 x6</p>  <p style="text-align: right;">VIS231</p>	
<p>I x6</p>  <p style="text-align: right;">CHE02</p>	<p>J x2</p>  <p style="text-align: right;">6272</p>	<p>K x2</p>  <p style="text-align: right;">SET128</p>
<p>L x2</p>  <p style="text-align: right;">SET134</p>	<p>M x2</p>  <p>Lg=1962mm J808</p>	<p>N x1</p>  <p>Lg=1962mm AI175</p>
<p>O x2</p>  <p style="text-align: right;">PGN49</p>	<p>P x4</p>  <p style="text-align: right;">BUT44</p>	<p>Q x2</p>  <p style="text-align: right;">PPL1248</p>
<p>R x4</p>  <p style="text-align: right;">PPL1339</p>	<p>S x1</p>  <p>Lg=1962mm AI176</p>	<p>T x4</p>  <p>Lg=1100mm J806</p>
<p>U x1</p>  <p style="text-align: right;">SET143</p>	<p>V Ø3.5 x2</p>  <p style="text-align: right;">VIS217</p>	<p>W x2</p>  <p style="text-align: right;">6270</p>

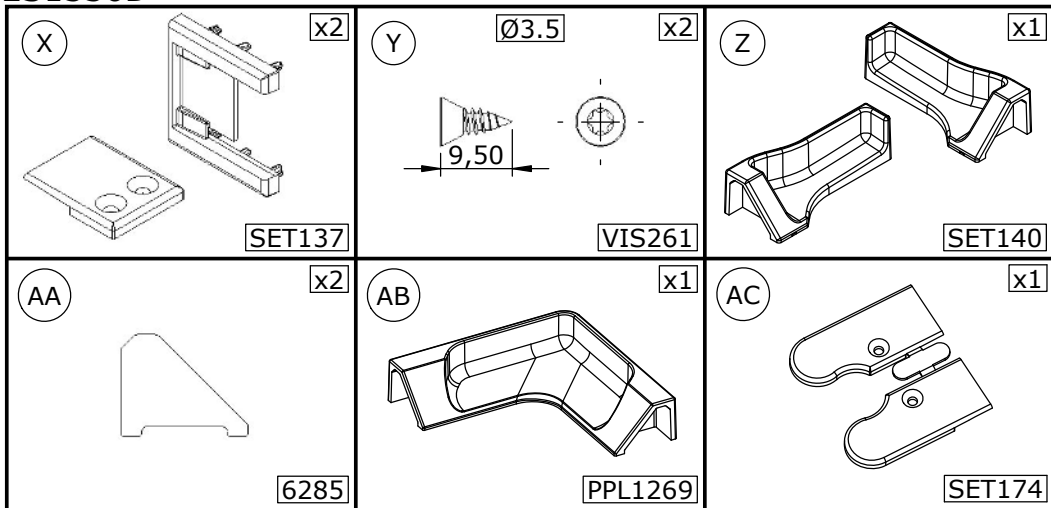

- Les quantités données sont les quantités utiles au montage. les sachets fournis contiennent des pièces supplémentaires.
 - The quantities given are what are required for the installation. There may be some surplus in the package provide.
- Las cantidades indicadas son las cantidades necesarias para el montaje. Las bolsitas incluidas contienen piezas suplementarias.
 - Le quantità fornite sono le quantità necessarie al montaggio. I sacchetti forniti contengono pezzi supplementari.
 - De aangegeven aantallen zijn vereist voor de montage. De verpakking bevat extra onderdelen.
- Die Mengenangaben beziehen sich auf die für die Montage nötigen Teile. Eventuell weitere beige packte Teile ignorieren.

● Outillage nécessaire ● Tools required ● Equipamiento necesario
 ● Attrezzatura necessaria ● Benodigde gereedschap ● Werkzeuge erforderlich

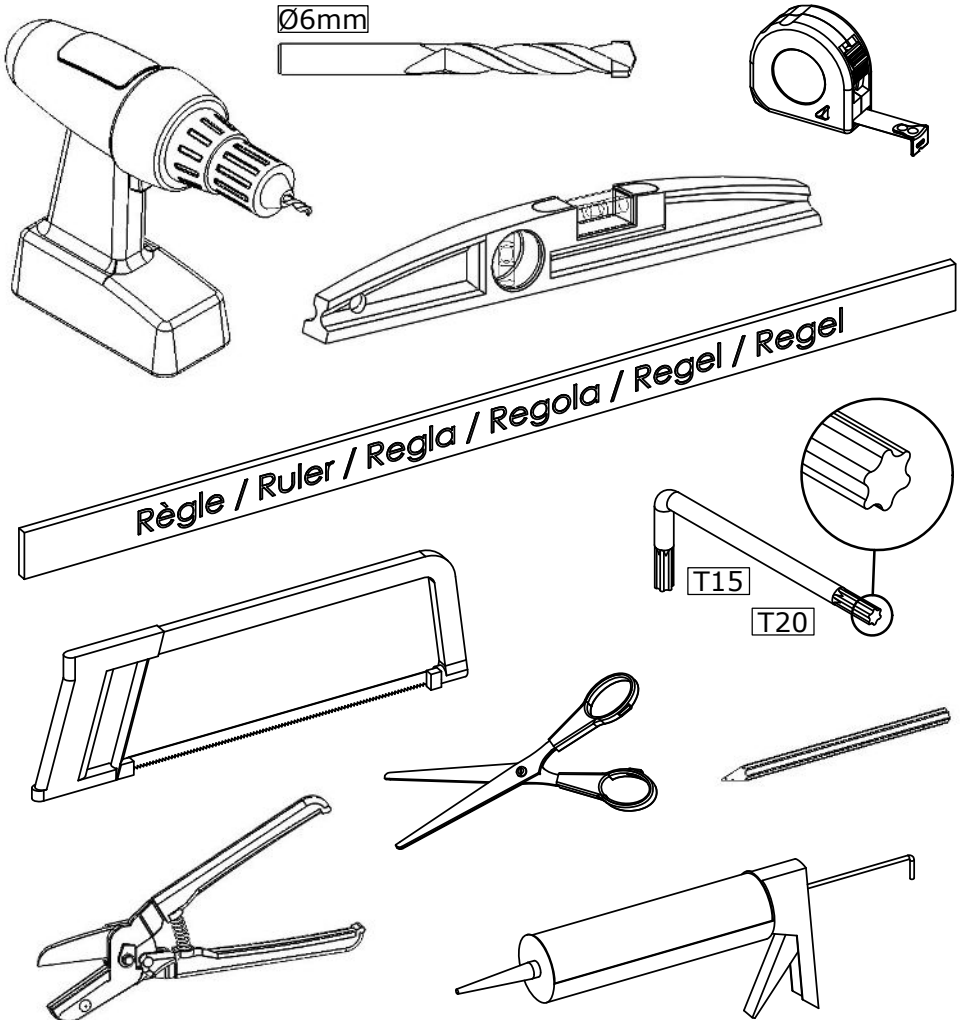

- Utiliser un silicone adapté au matériau de chaque support (faïence, acrylique, etc.)
- Use a silicone sealant that is intended for the surrounding materials (ceramic, acrylic, etc.)
 - Usar una silicona adecuada para cada tipo de material (loza, acrílico, etc.)
 - Utilizzare un silicone adatto a qualsiasi materiale (ceramica, acrilico, ecc.)
- Gebruik siliconenkit die geschikt is voor iedere ondergrond (tegelwerk, acryl, etc.)
- Für das jeweilige Trägermaterial (Stein, Acryl usw.) geeignetes Silikon verwenden.



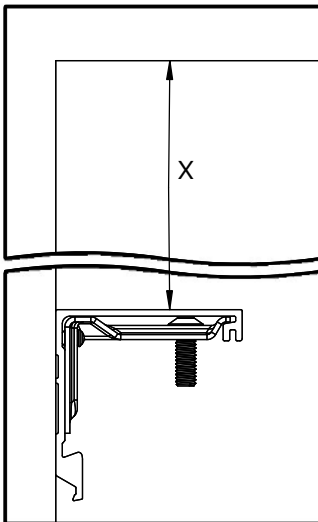
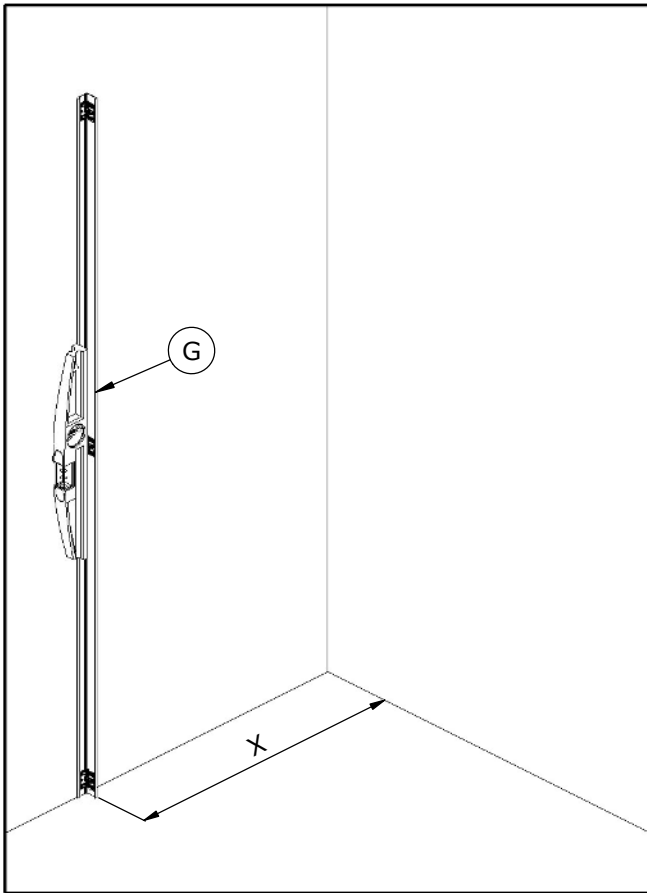

DIMENSIONS (cm)	X (mm)
70	630 - 645
75	680 - 685
80	730 - 745
85	780 - 785
90	830 - 845
95	880 - 885
100	930 - 945

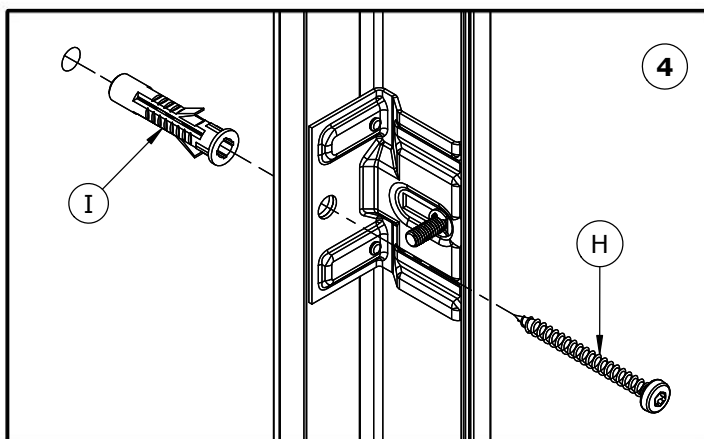
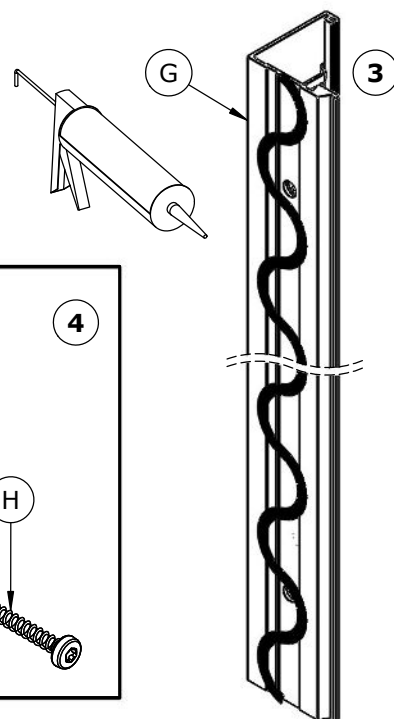
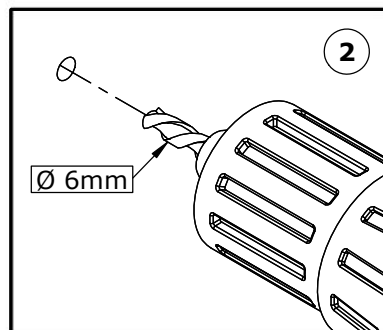
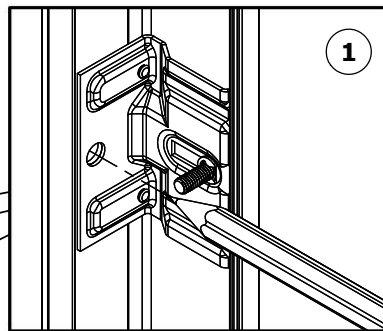
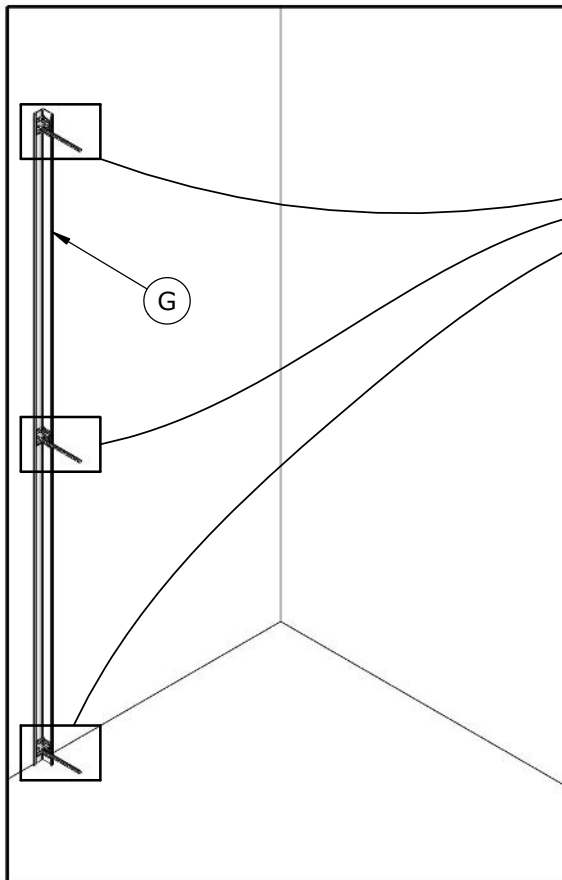

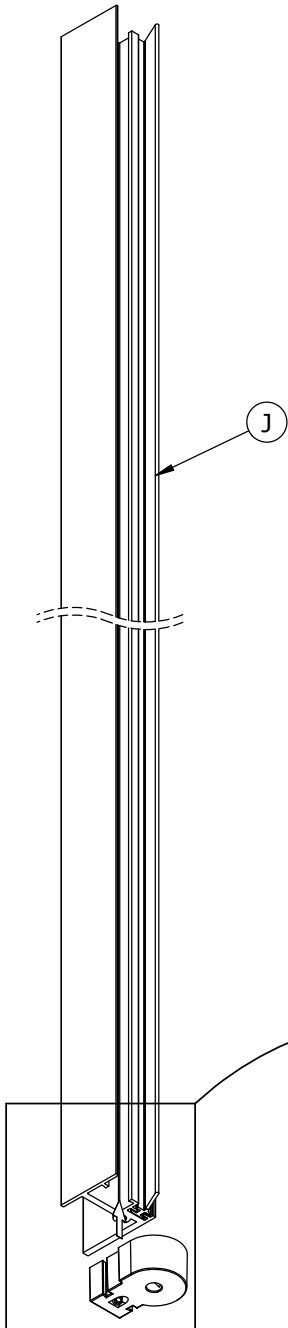

- Affleurant ● Flush
- Afloramiento ● Affioramento
- Doorspoelen ● Bündig

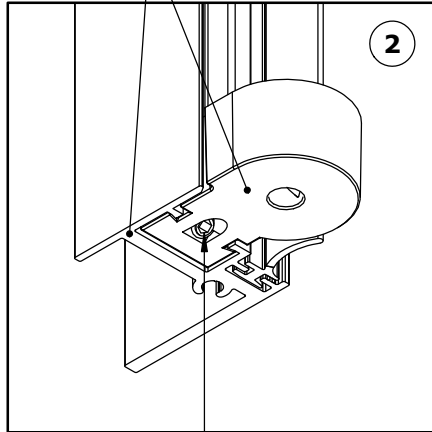

- Serrer fort ● Tighten hard
- Apretar fuerte ● Serrare forte
- Draai stevig vast ● Fest anziehen

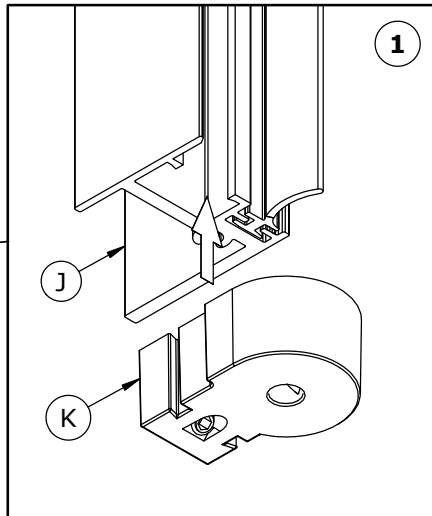

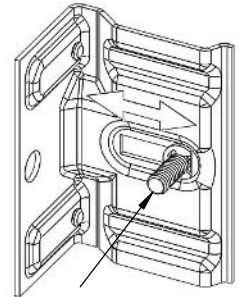
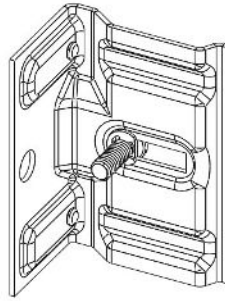

- Si nécessaire, desserrer, régler puis resserrer
- If necessary, loosen, adjust and retighten
- Si es necesario, afloje, ajuste y apriete
- Se necesario, allentare, regolare e stringere
- Draai los, indien nodig, stel af en draai vervolgens weer vast
- Falls erforderlich, lösen, einstellen und wieder festziehen

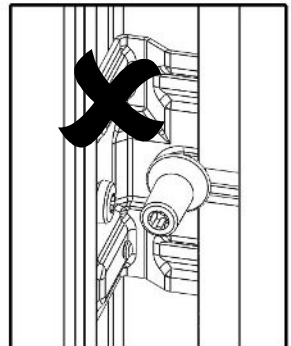
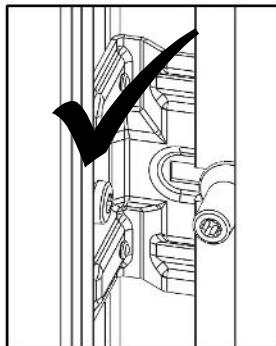
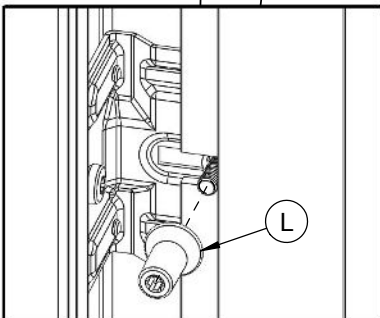

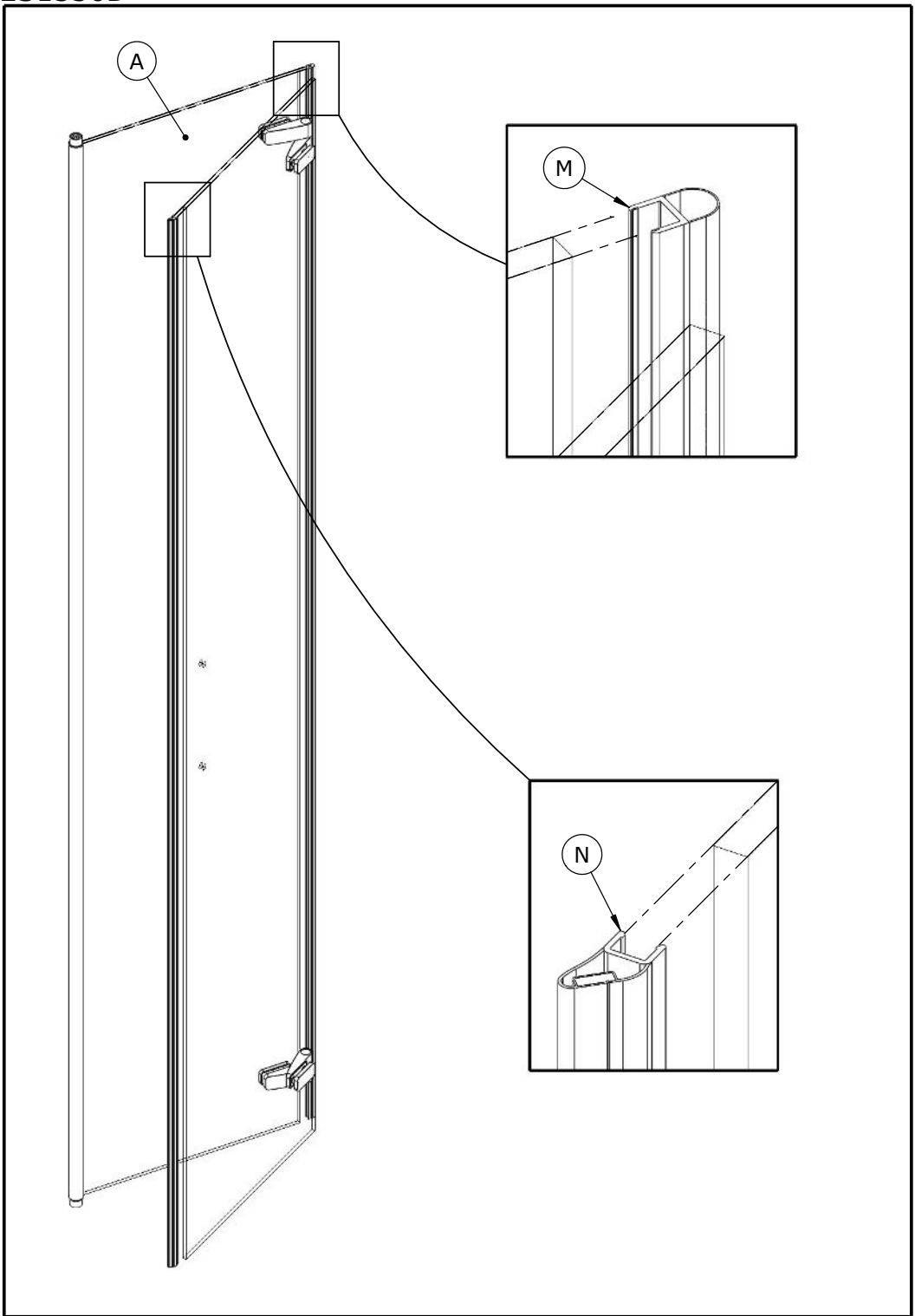

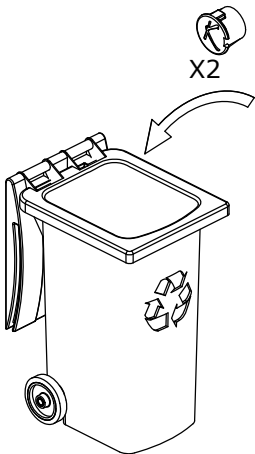
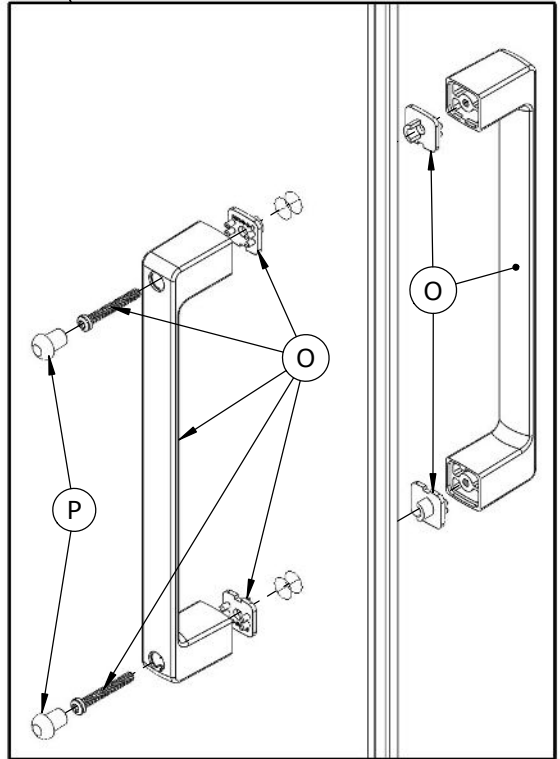
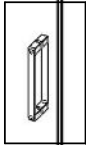
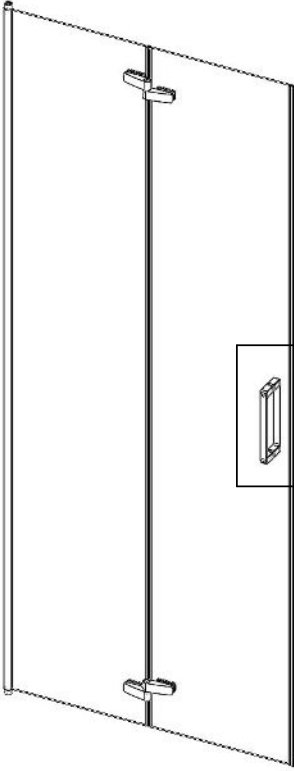

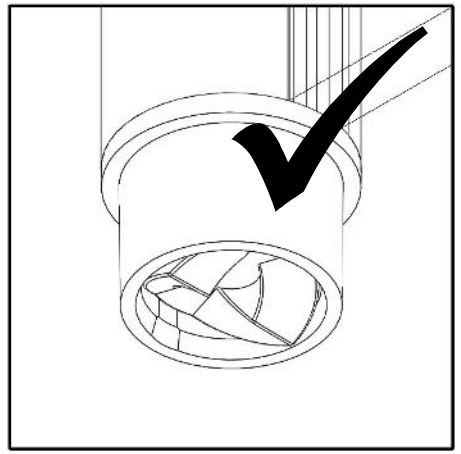
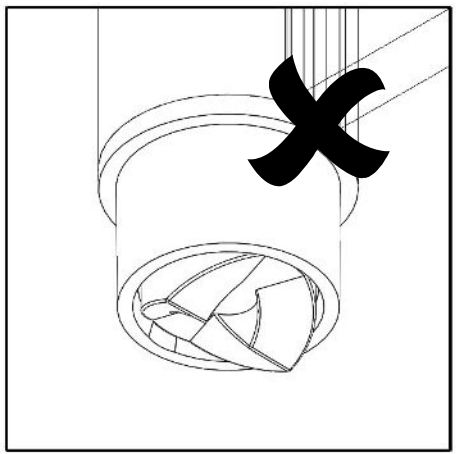
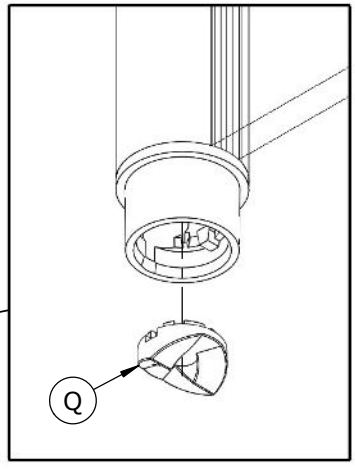
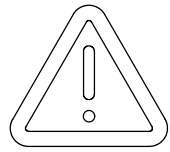
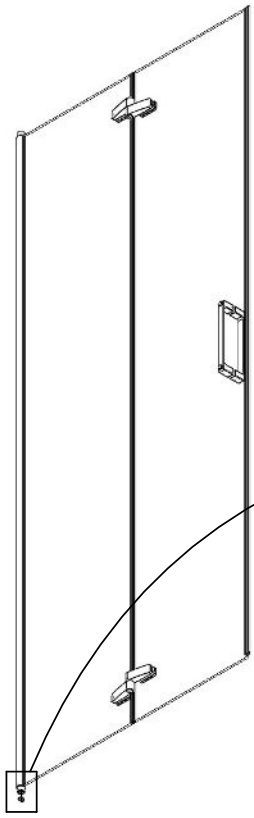

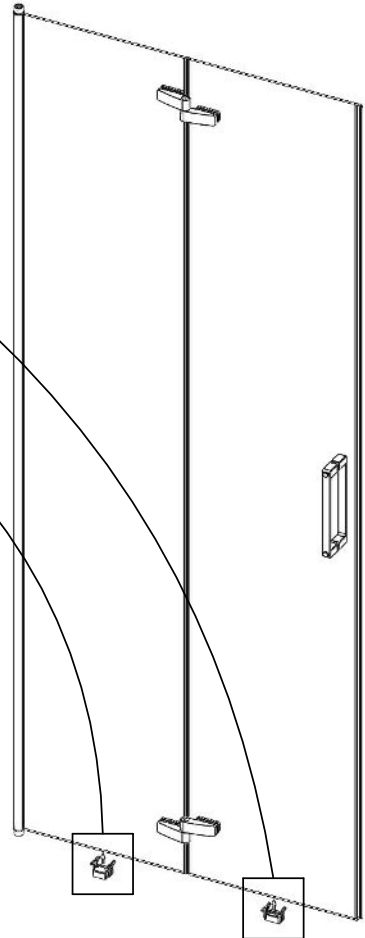
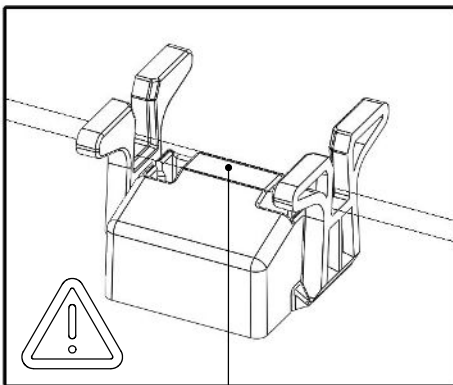
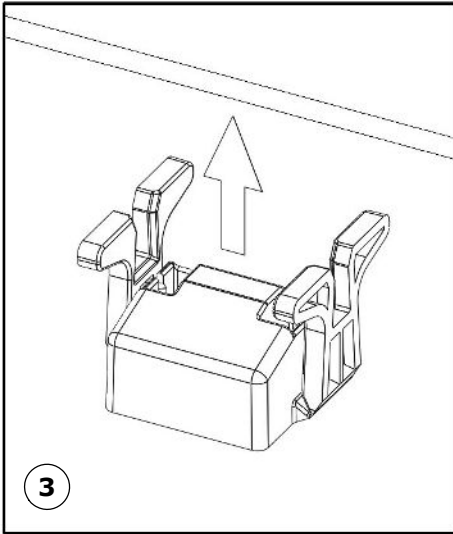
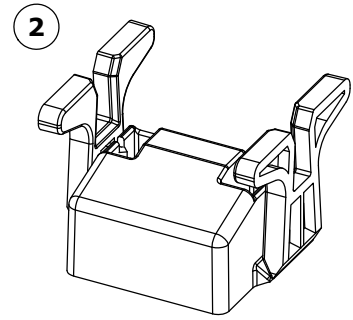
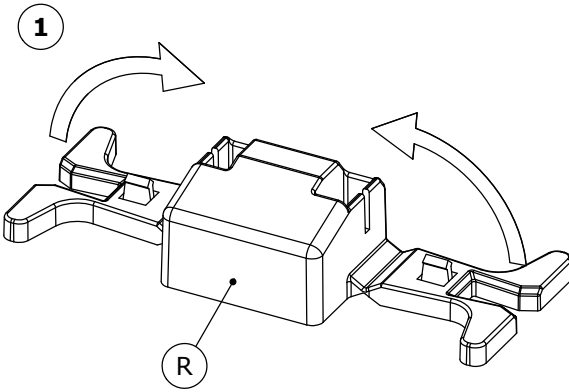

- Mettre en contact ● Put in contact
- Poner en contacto ● Mettere in contatto
- Mensen in contact te brengen ● Kontakte knüpfen

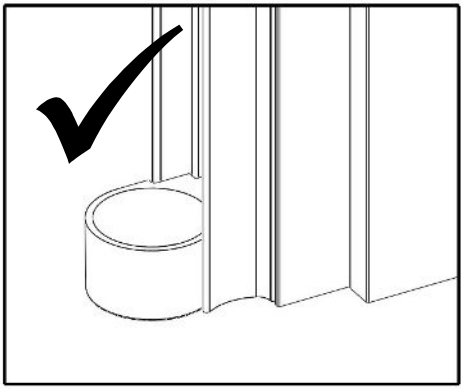
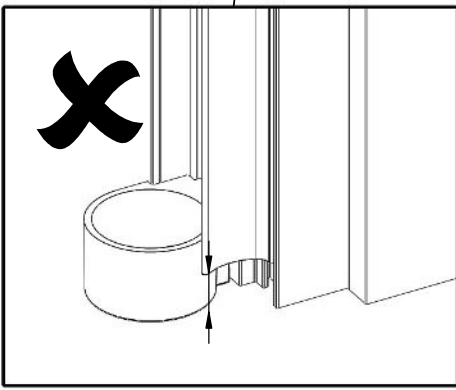
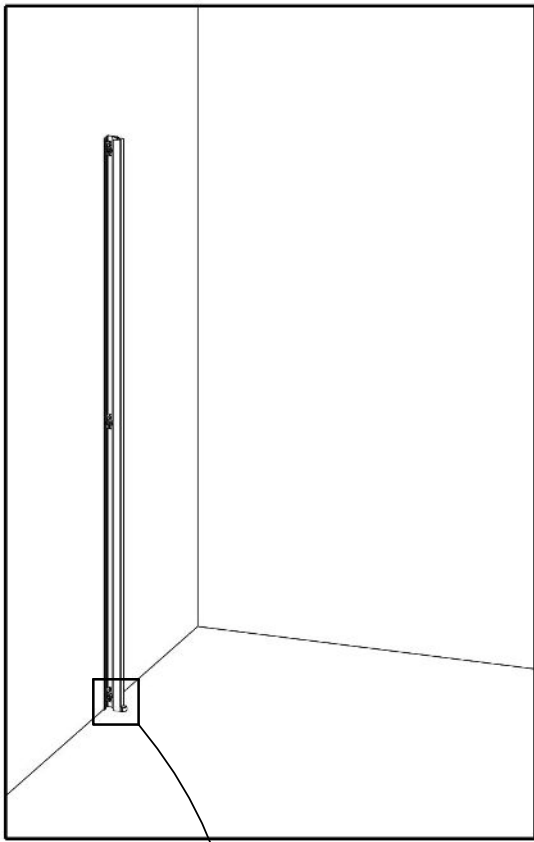

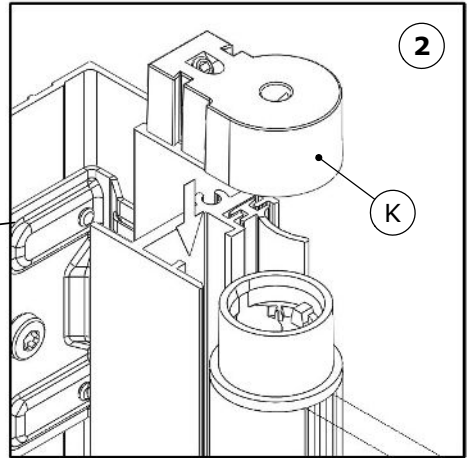
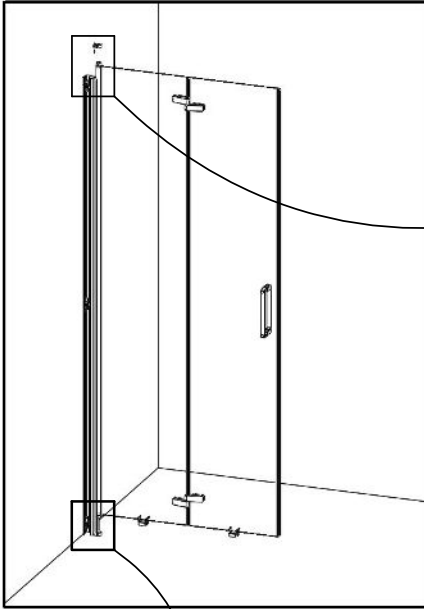

- Affleurant ● Flush
 ● Afloramiento ● Affioramento
 ● Doorspoelen ● Bündig

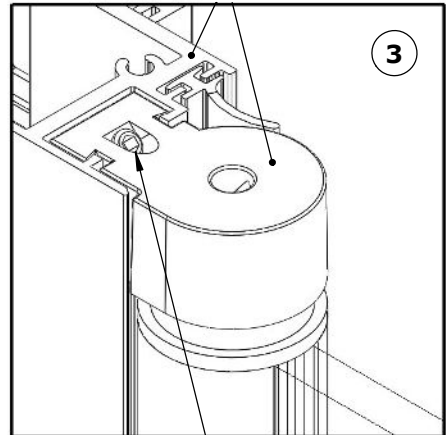
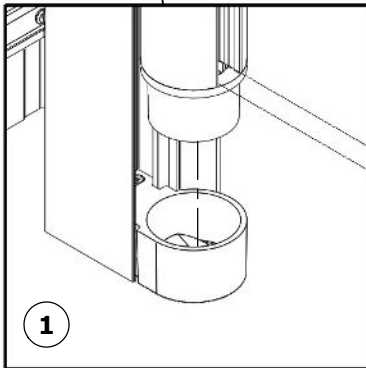

- Serrer fort ● Tighten hard
 ● Apretar fuerte ● Serrare forte
 ● Draai stevig vast ● Fest aanziehen

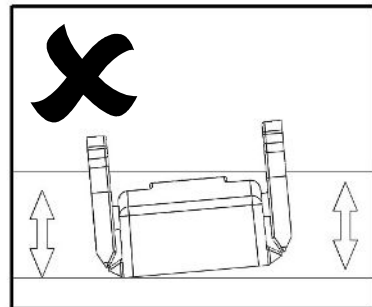
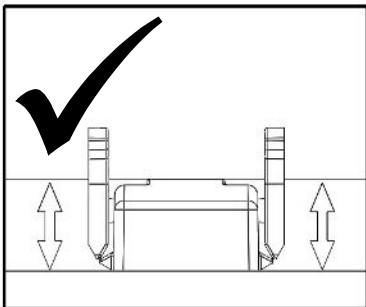

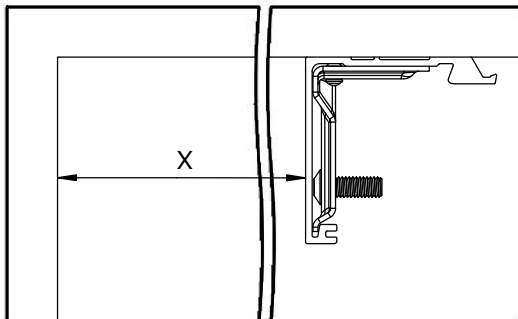
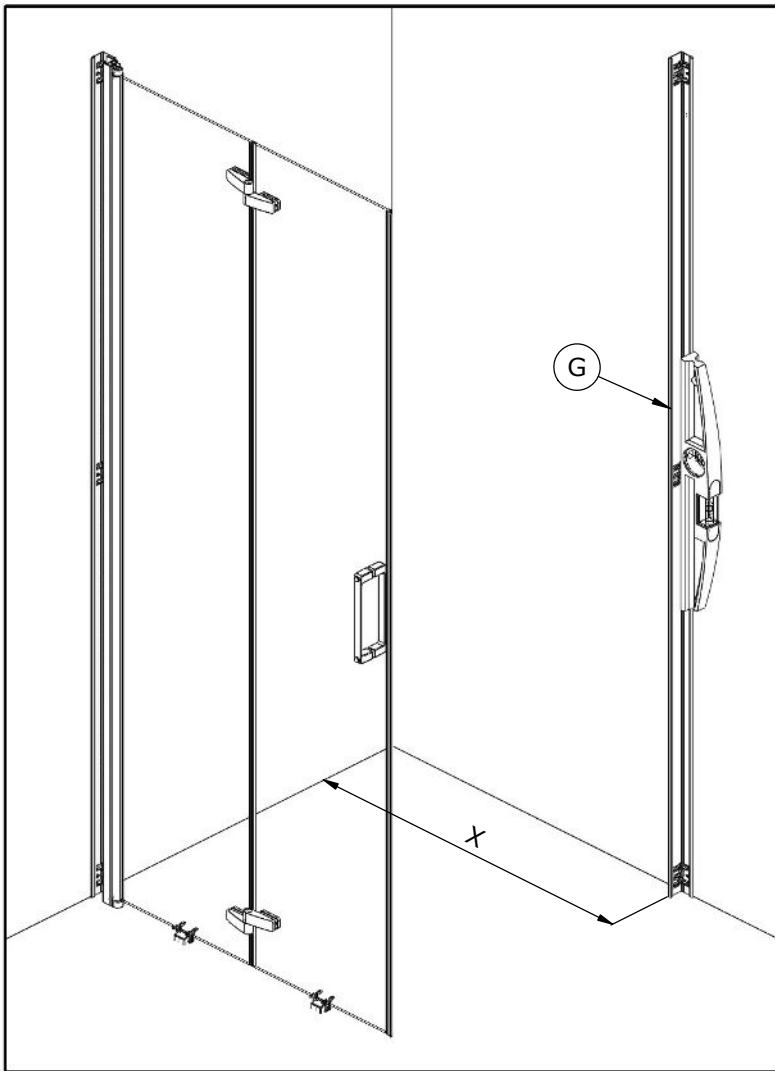

DIMENSIONS (cm)	X (mm)
70	630 - 645
75	680 - 685
80	730 - 745
85	780 - 785
90	830 - 845
95	880 - 885
100	930 - 945

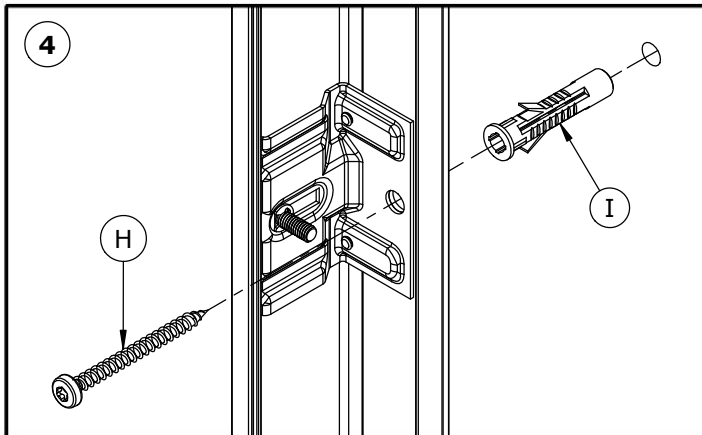
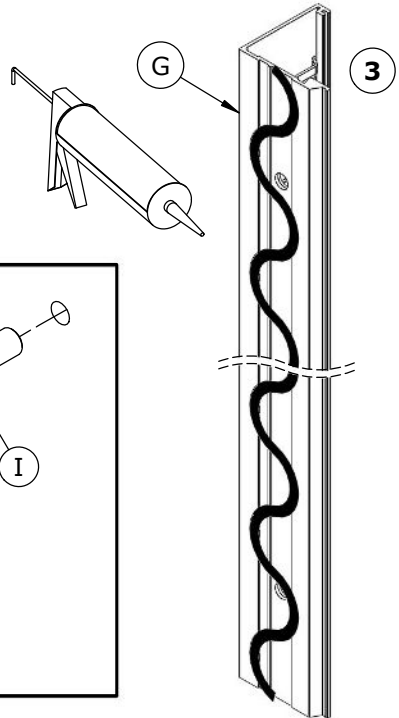
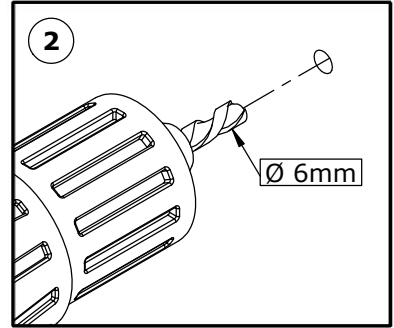
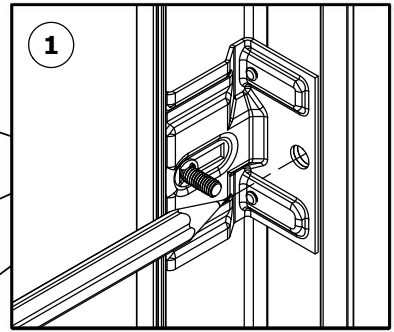
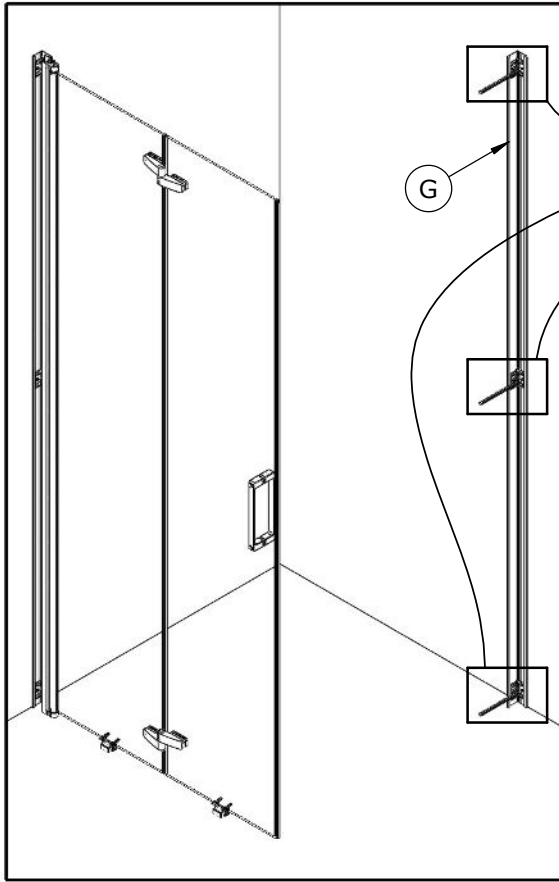

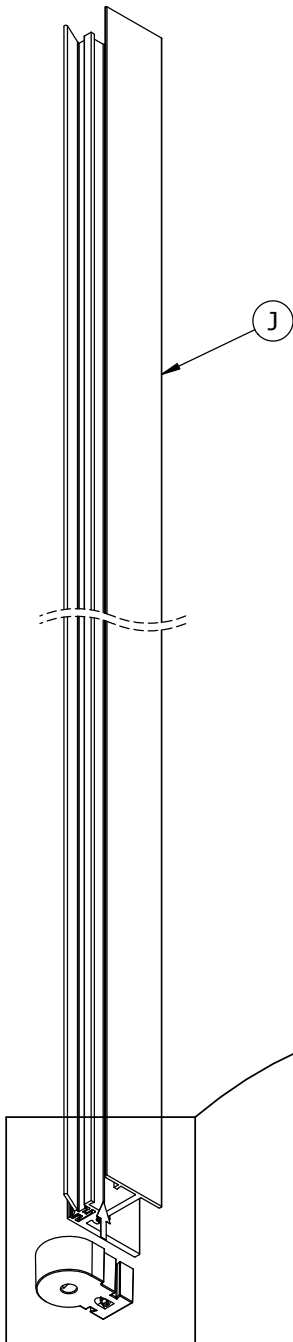

● Affleurant ● Flush
 ● Afloramiento ● Affioramento
 ● Doorspoelen ● Bündig

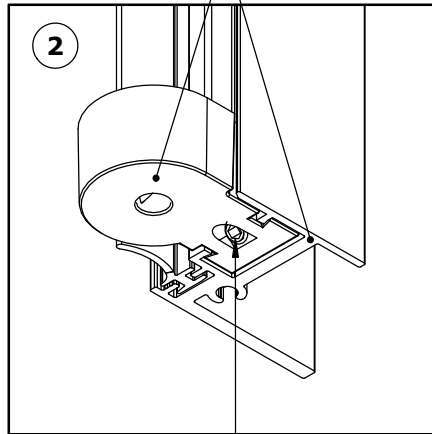

● Serrer fort ● Tighten hard
 ● Apretar fuerte ● Serrare forte
 ● Draai stevig vast ● Fest anziehen

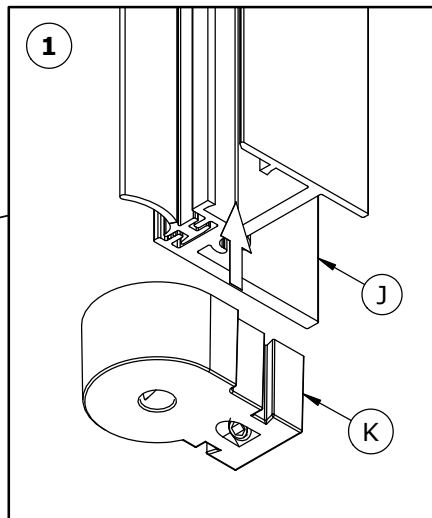

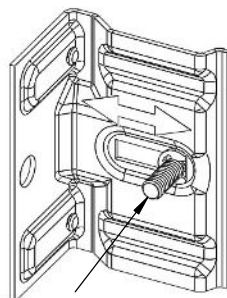
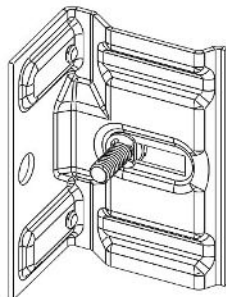
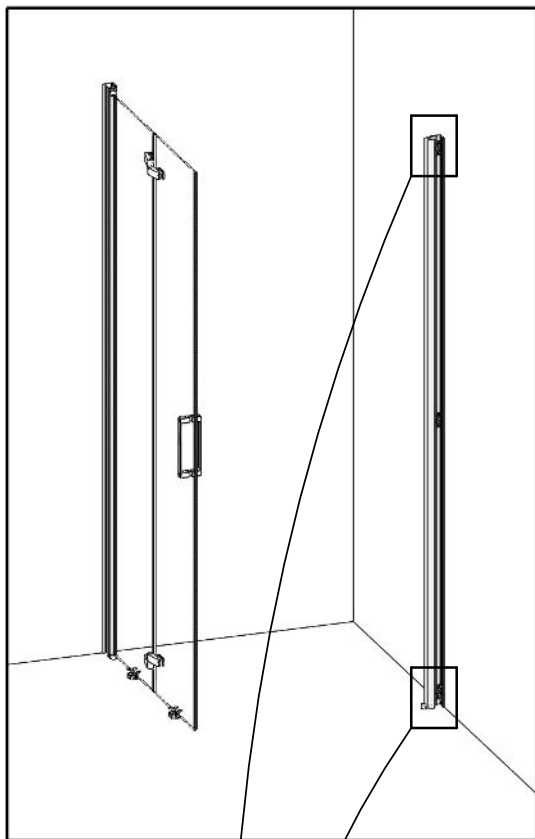

- Si nécessaire, desserrer, régler puis resserrer
- If necessary, loosen, adjust and retighten
- Si es necesario, afloje, ajuste y apriete
- Se necesario, allentare, regolare e stringere
- Draai los, indien nodig, stel af en draai vervolgens weer vast
- Falls erforderlich, lösen, einstellen und wieder festziehen

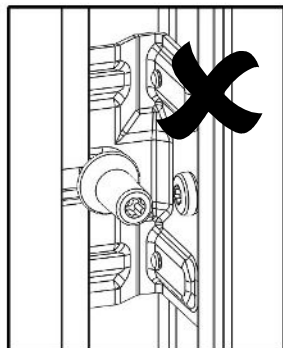
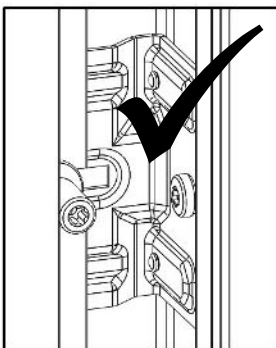
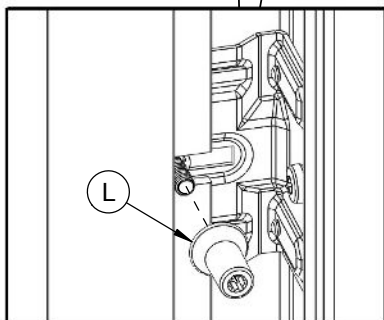

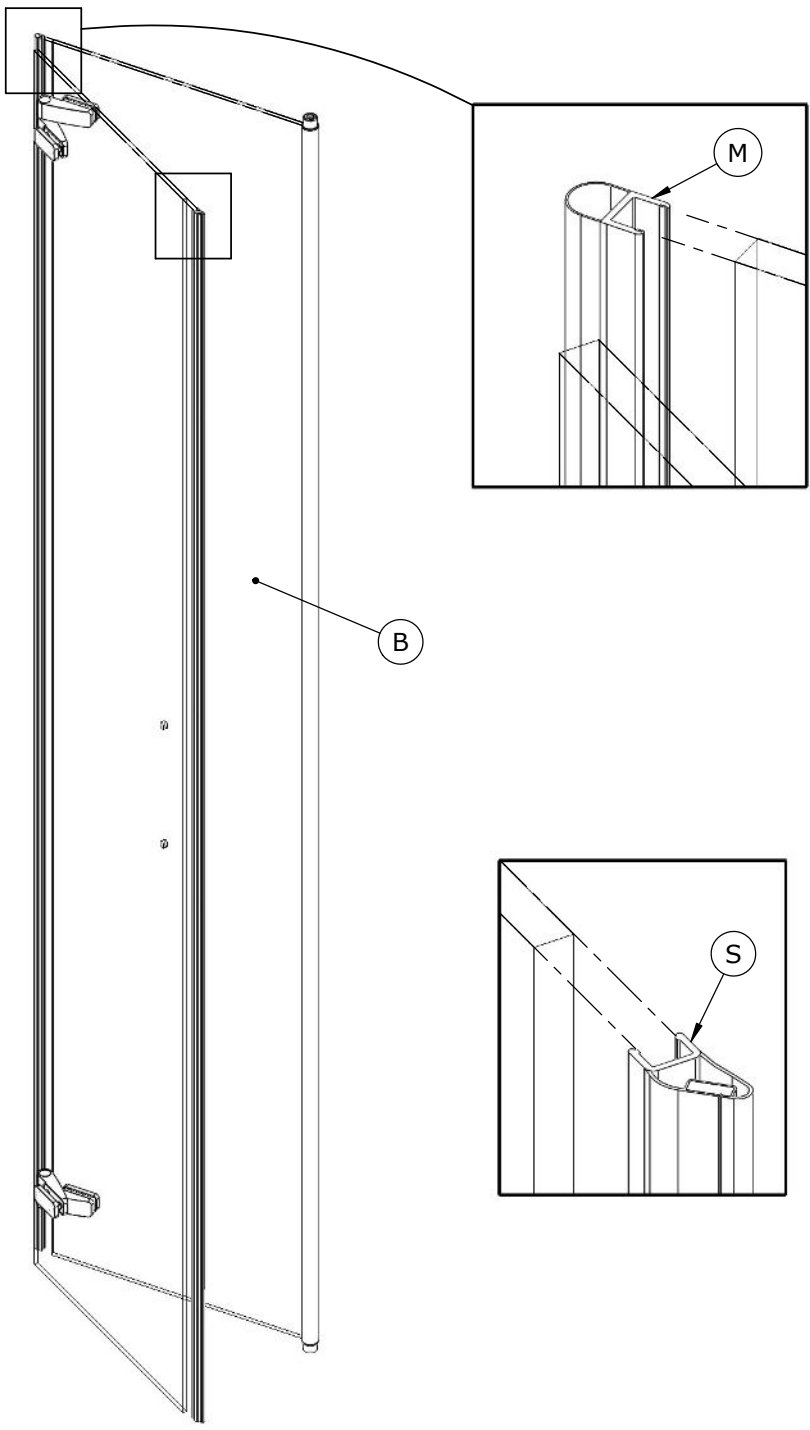

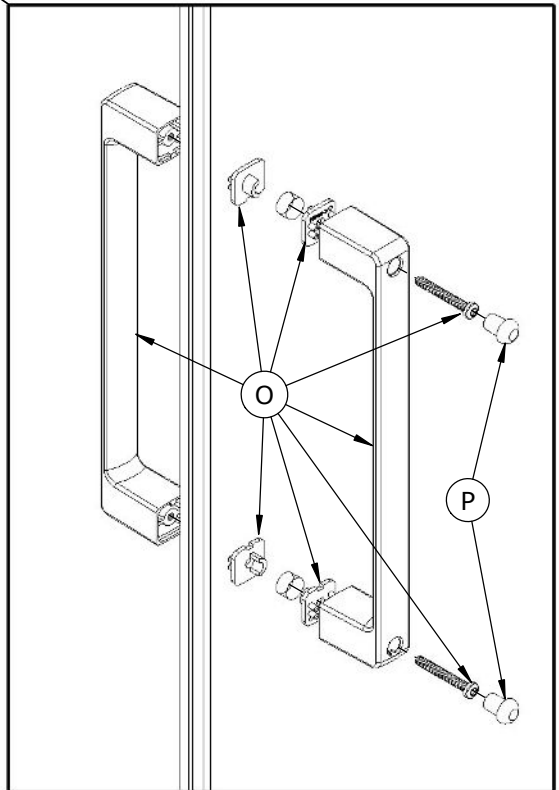
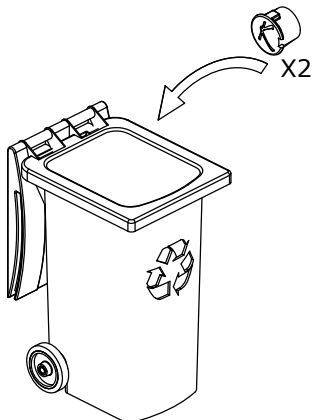
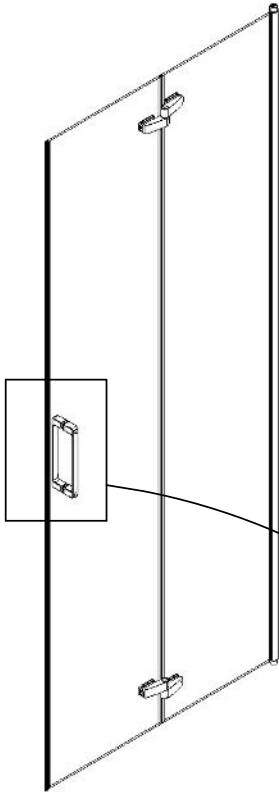

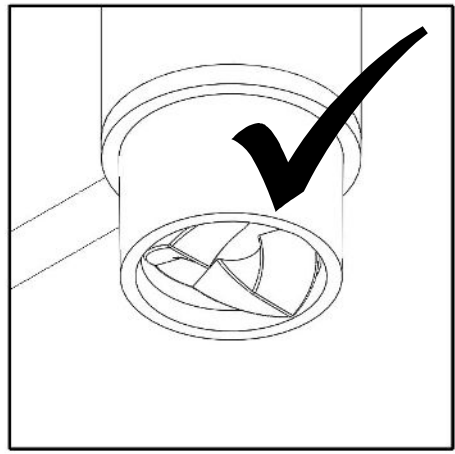
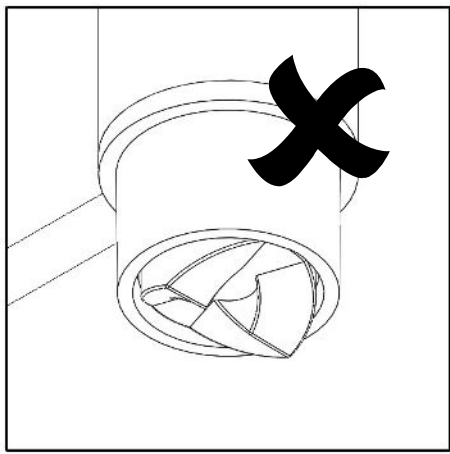
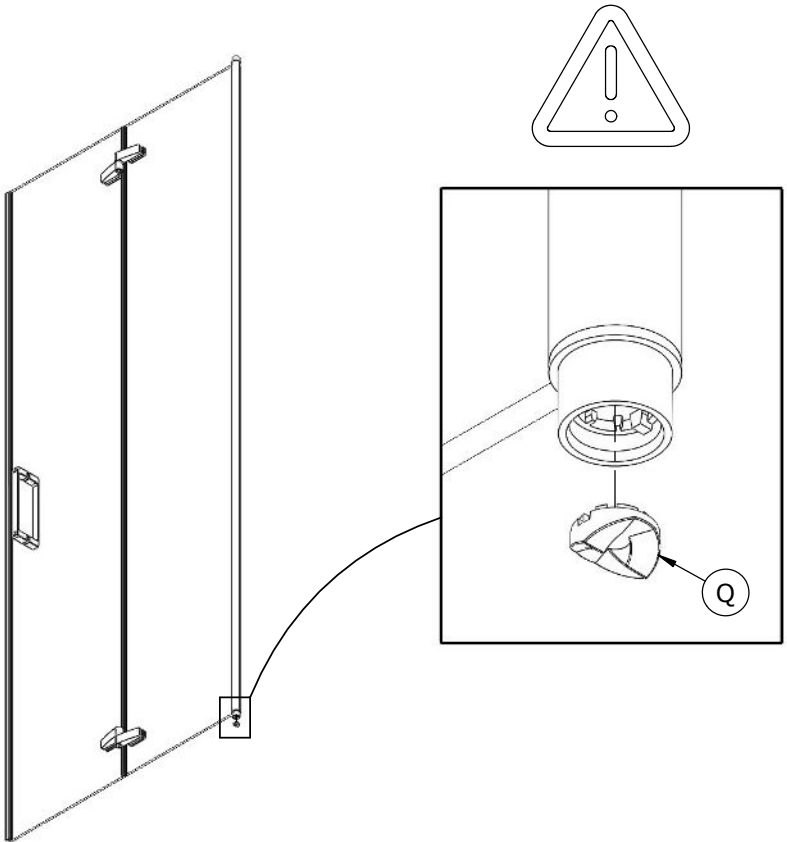

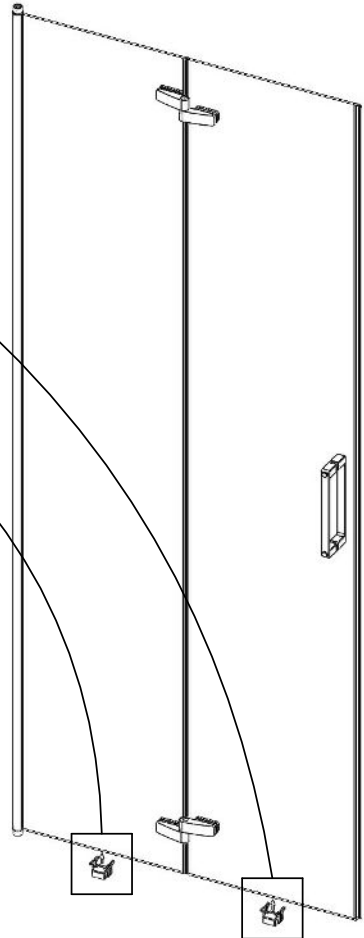
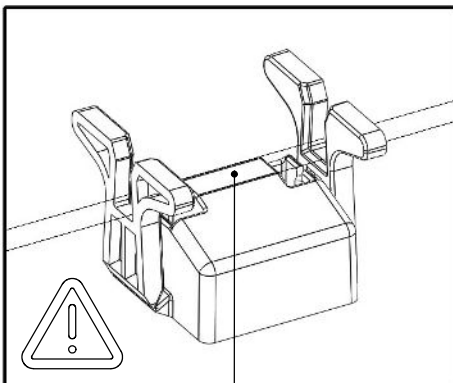
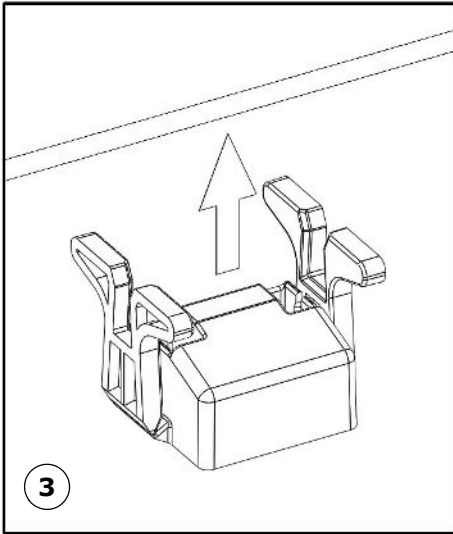
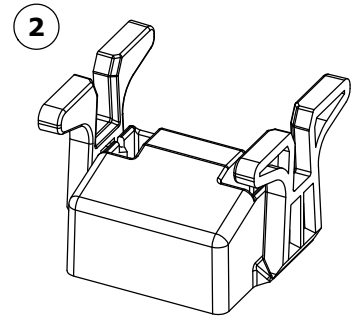
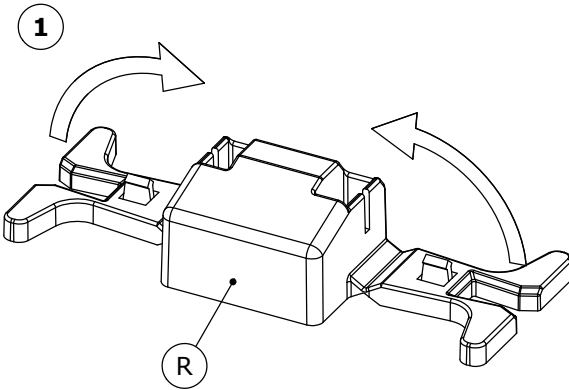

- Mettre en contact ● Put in contact
- Poner en contacto ● Mettere in contatto
- Mensen in contact te brengen ● Kontakte knüpfen

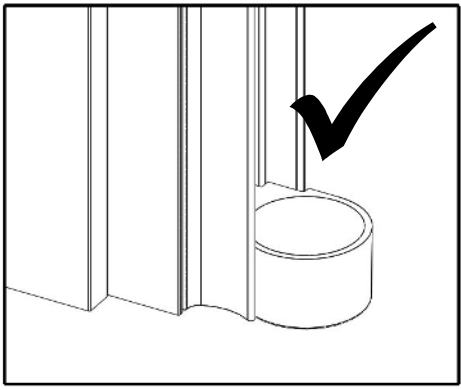
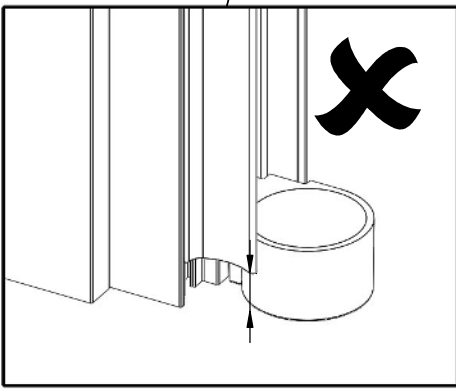
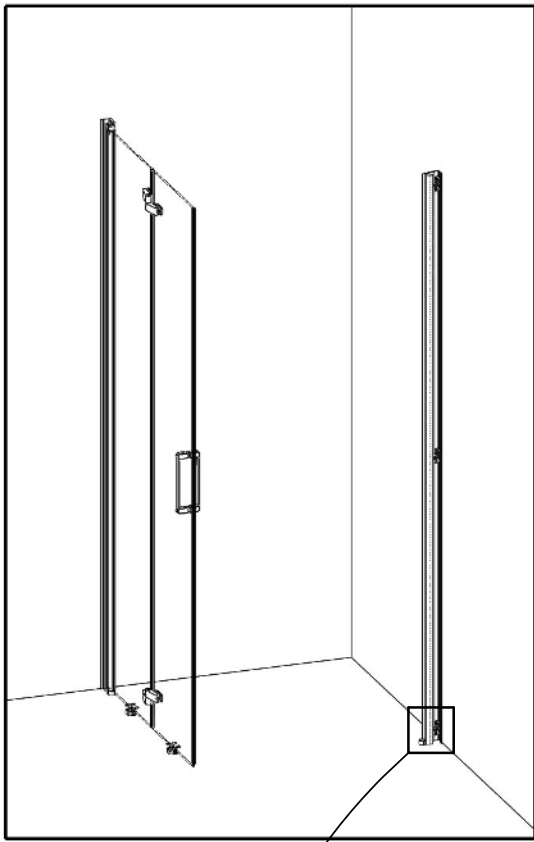

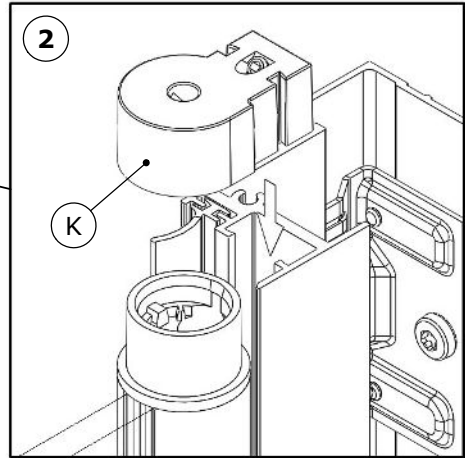
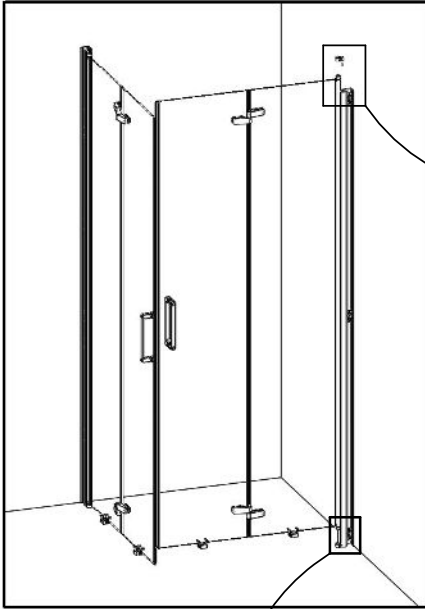

- Affleurant ● Flush
 ● Afloramiento ● Affioramento
 ● Doorspoelen ● Bündig

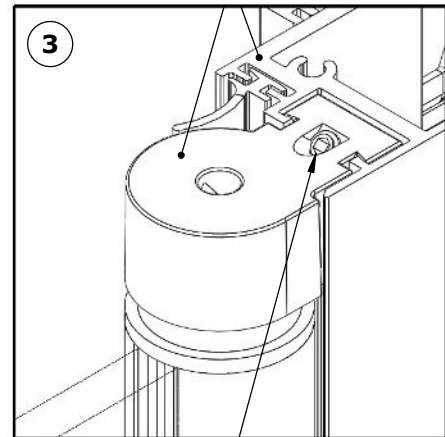
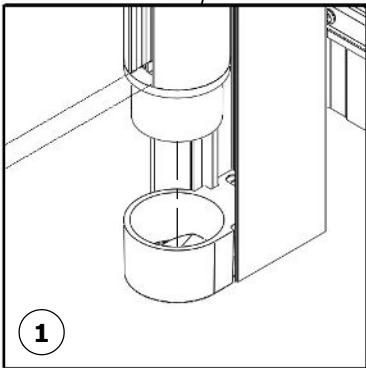

- Serrer fort ● Tighten hard
 ● Apretar fuerte ● Serrare forte
 ● Draai stevig vast ● Fest anziehen

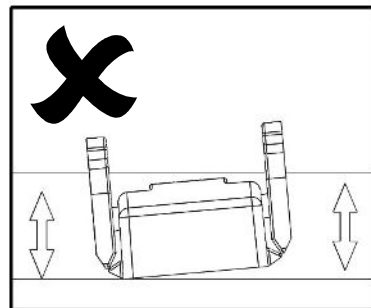
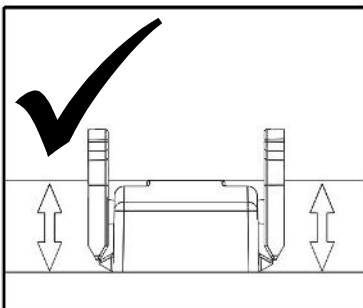

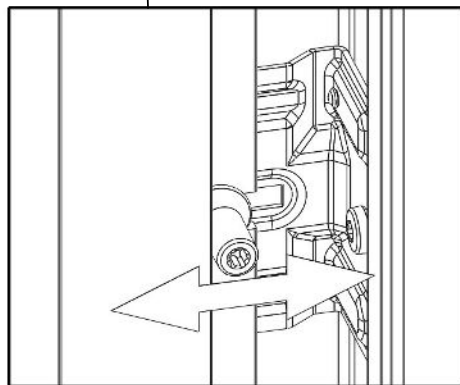
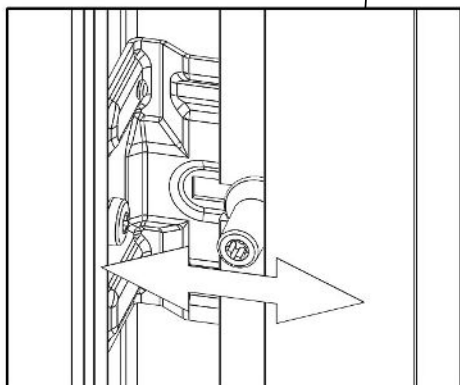
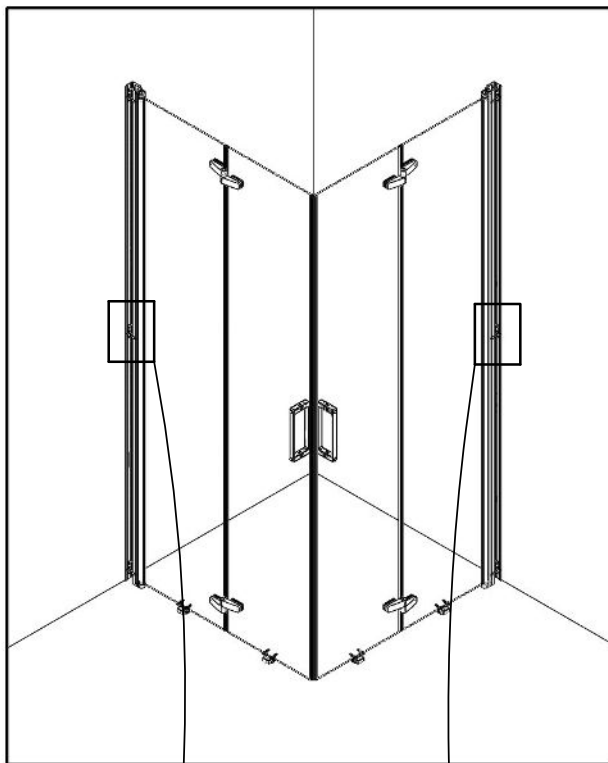

- Si nécessaire, desserrer, régler puis resserrer
- If necessary, loosen, adjust and retighten
- Si es necesario, afloje, ajuste y apriete
- Se necessario, allentare, regolare e stringere
- Draai los, indien nodig, stel af en draai vervolgens weer vast
- Falls erforderlich, lösen, einstellen und wieder festziehen

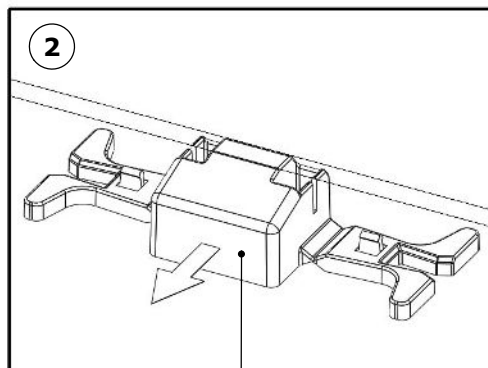
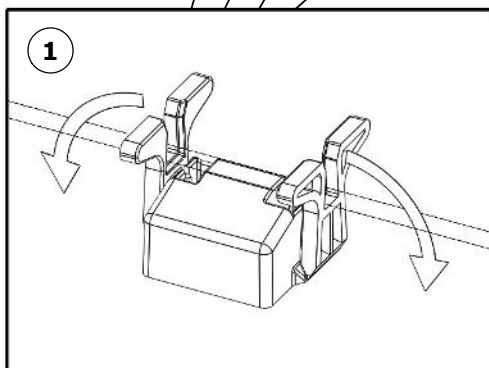
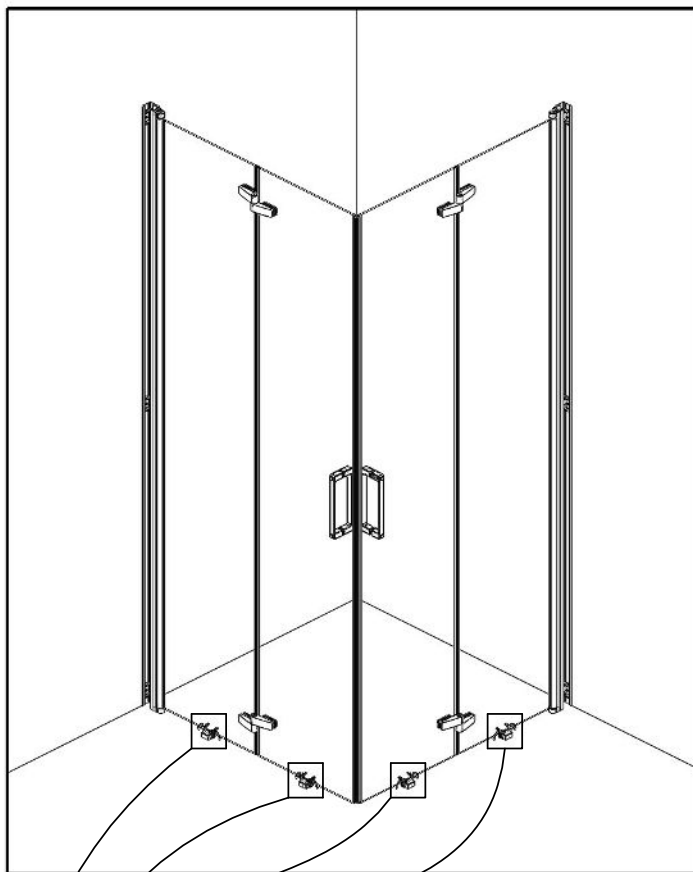

- Retirer ●B Remove
 ● Quitar ●I Togliere
 ●NL Verwijderen ●D Entfernen

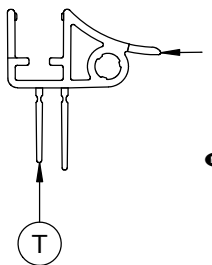

- Intérieur
- Inside
- Interior
- Interno
- Binnenkant
- Innen

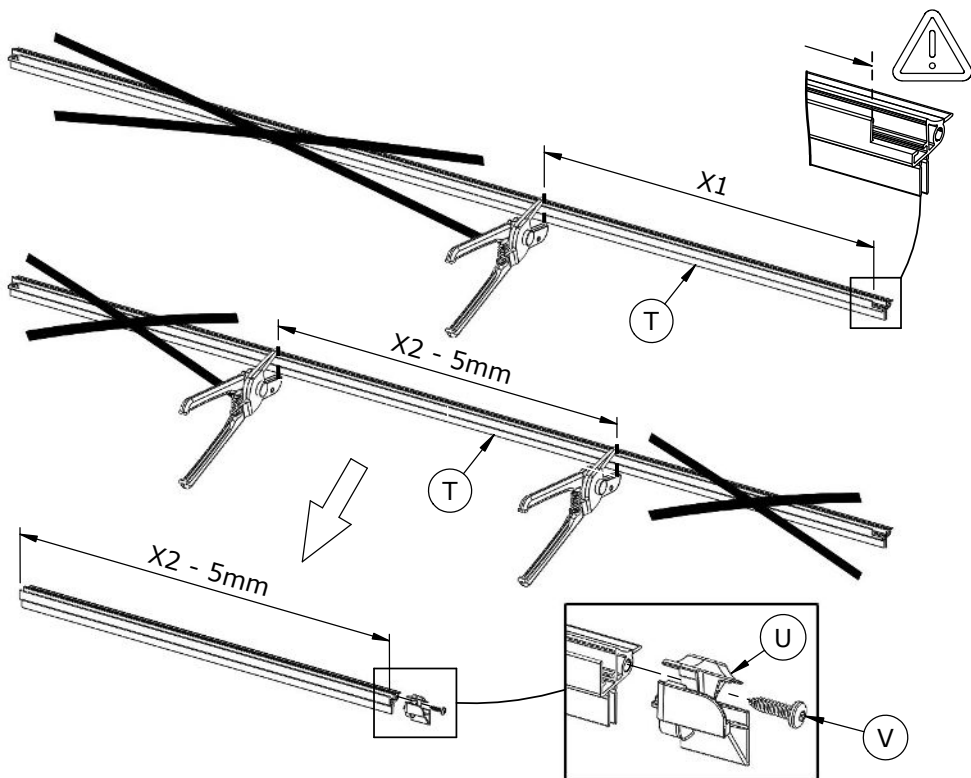
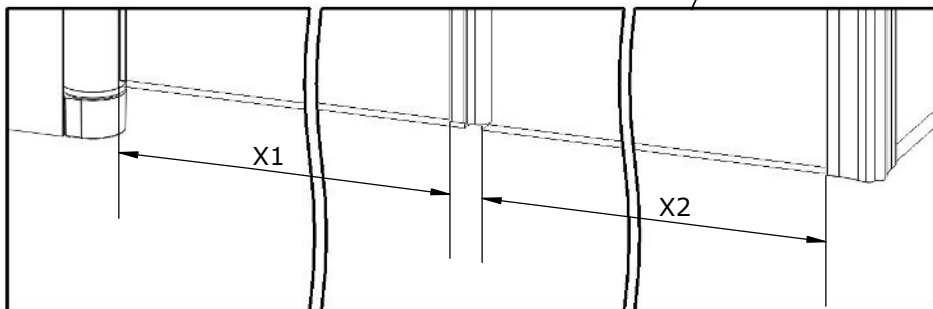
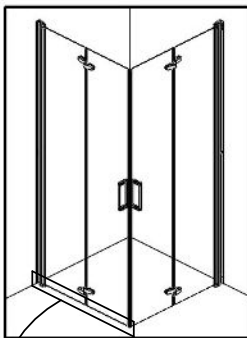

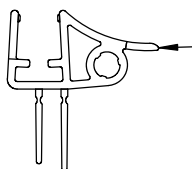

- Intérieur
- Inside
- Interior
- Interno
- Binnenkant
- Innen

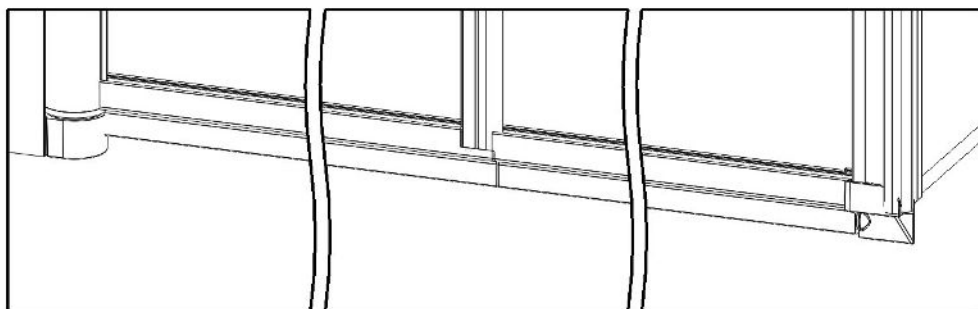
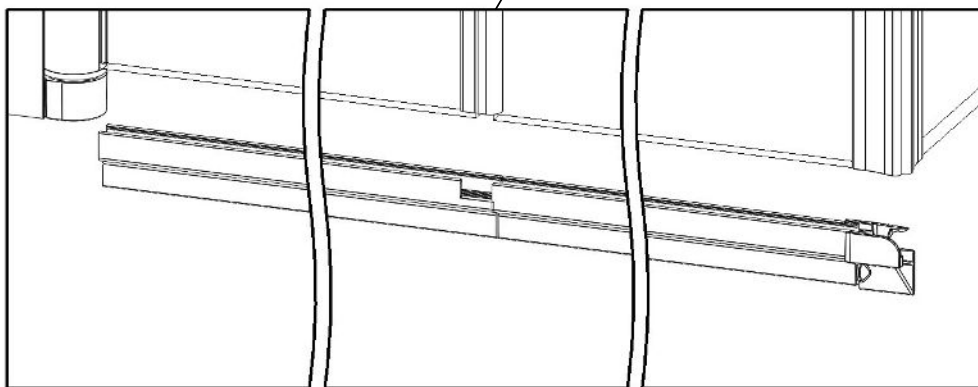
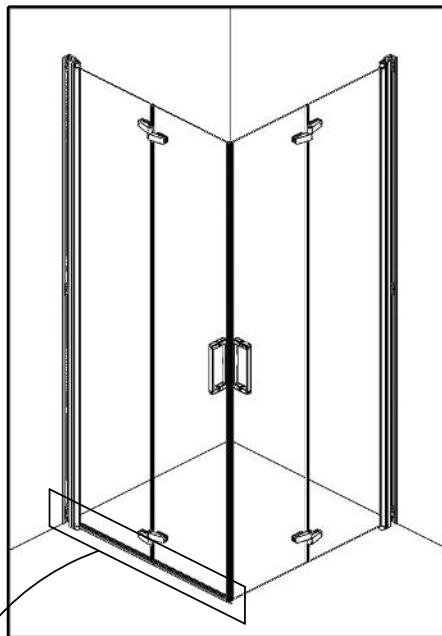

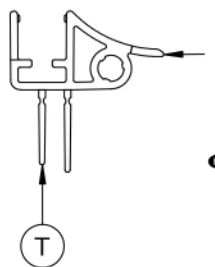

- Intérieur
- Inside
- Interior
- Interno
- Binnenkant
- Innen

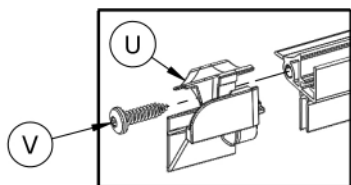
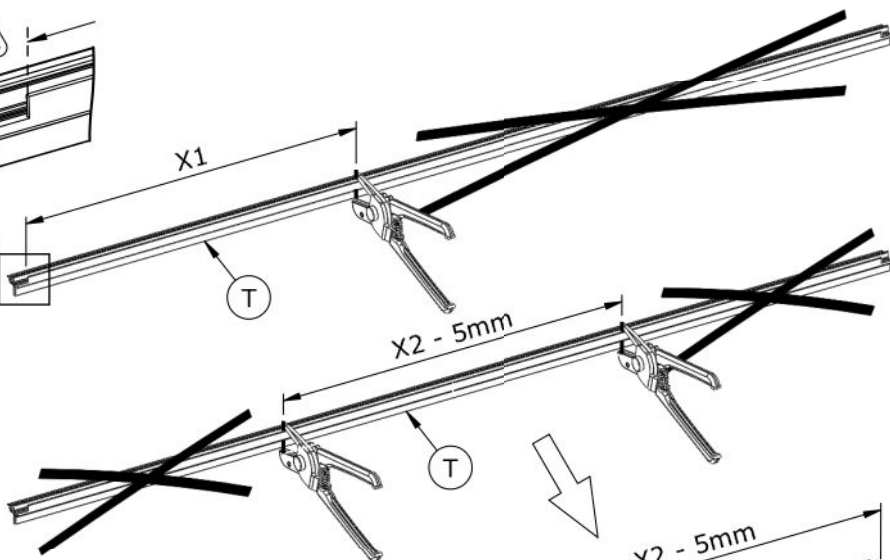
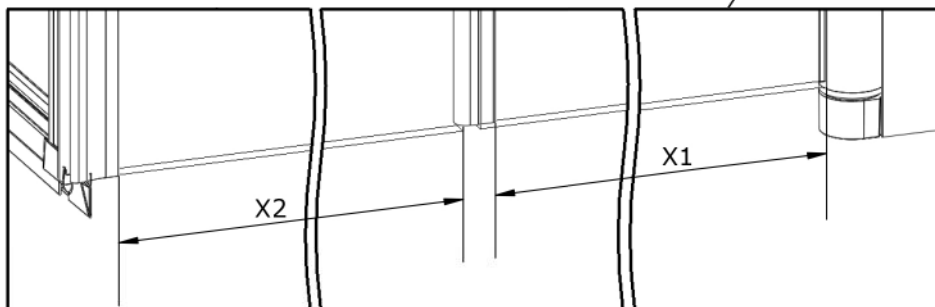
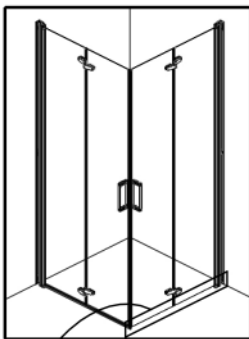

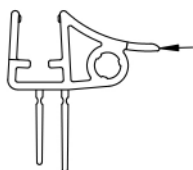

- Intérieur
- Inside
- Interior
- Interno
- Binnenkant
- Innen

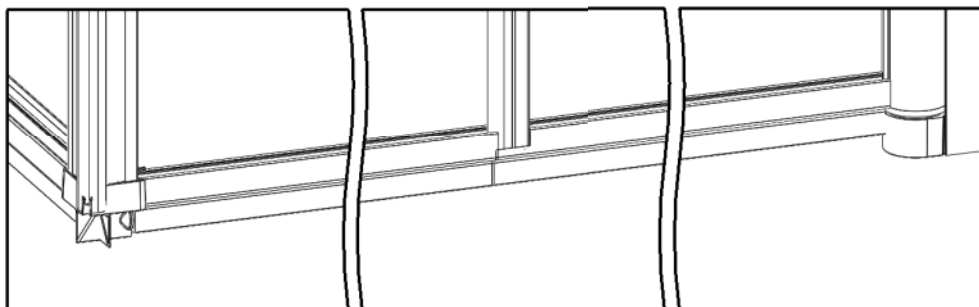
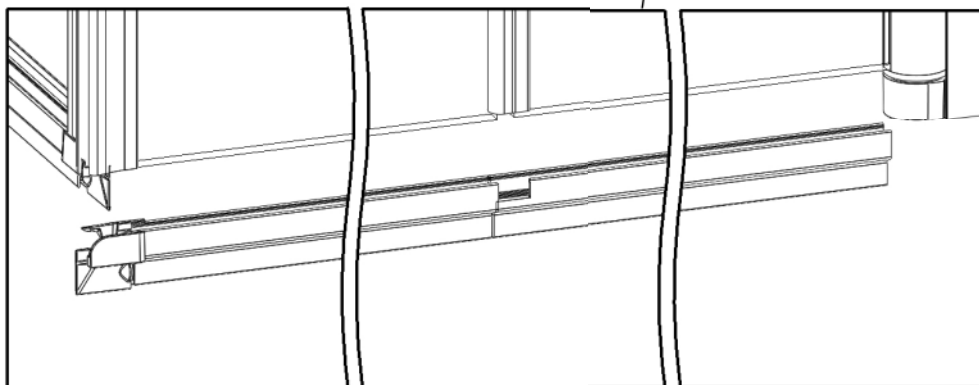
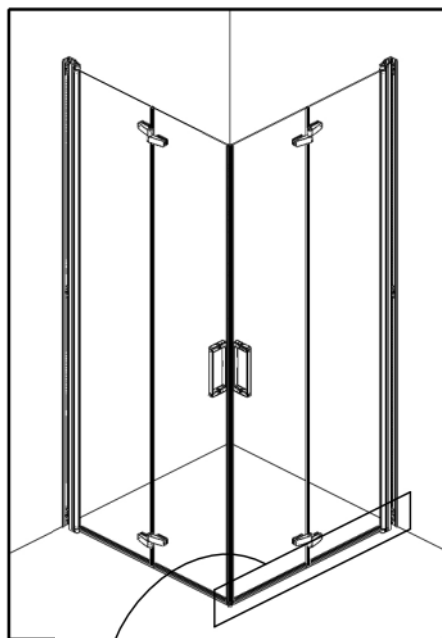

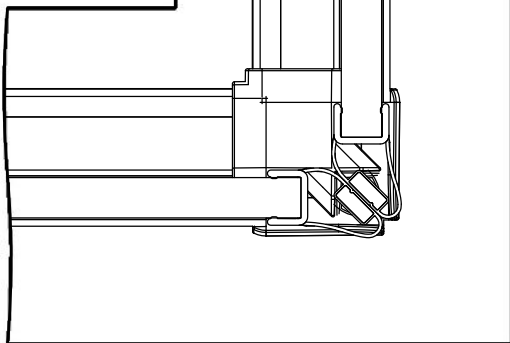
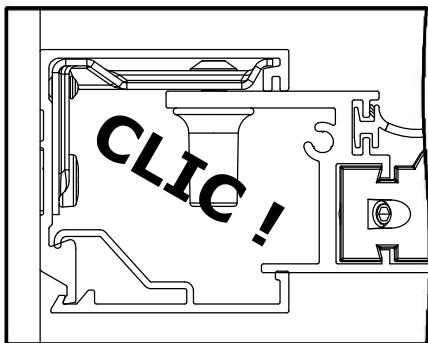
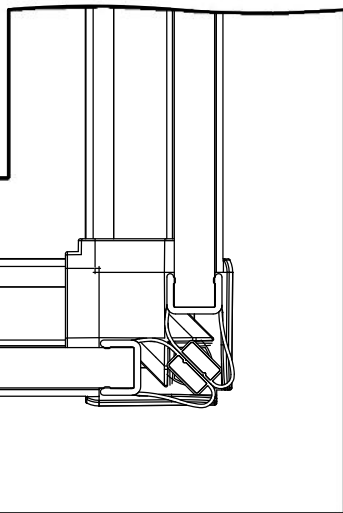
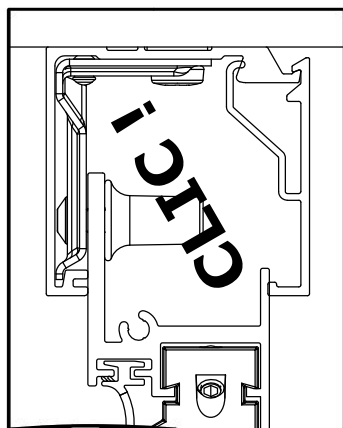
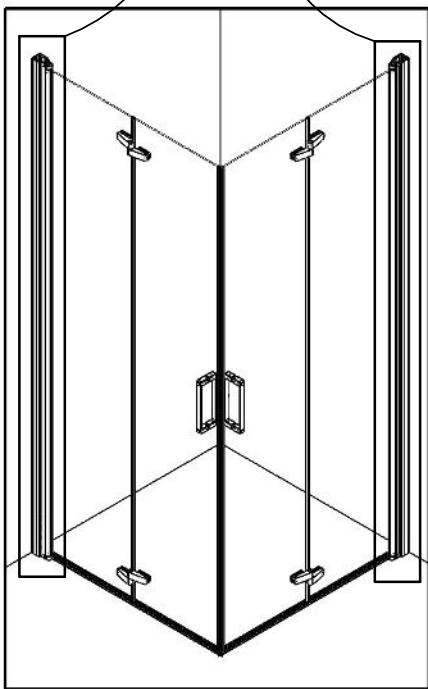
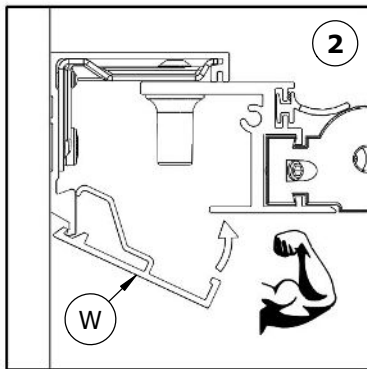
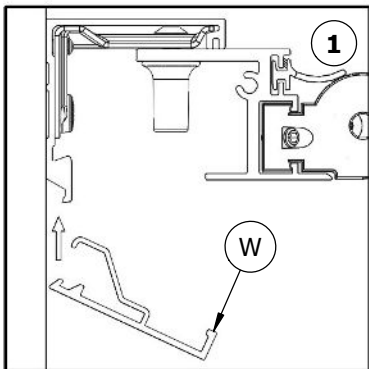

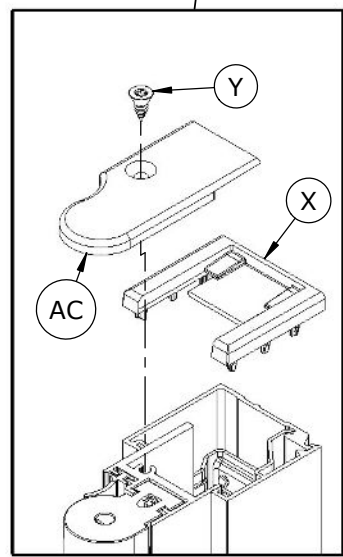
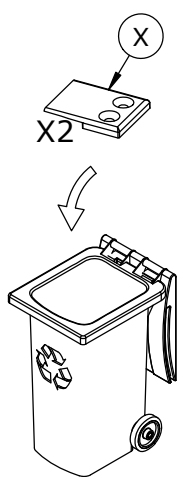
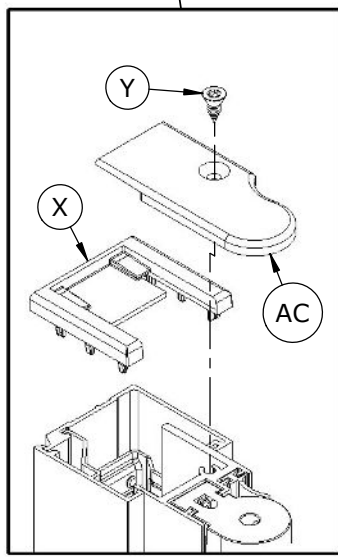
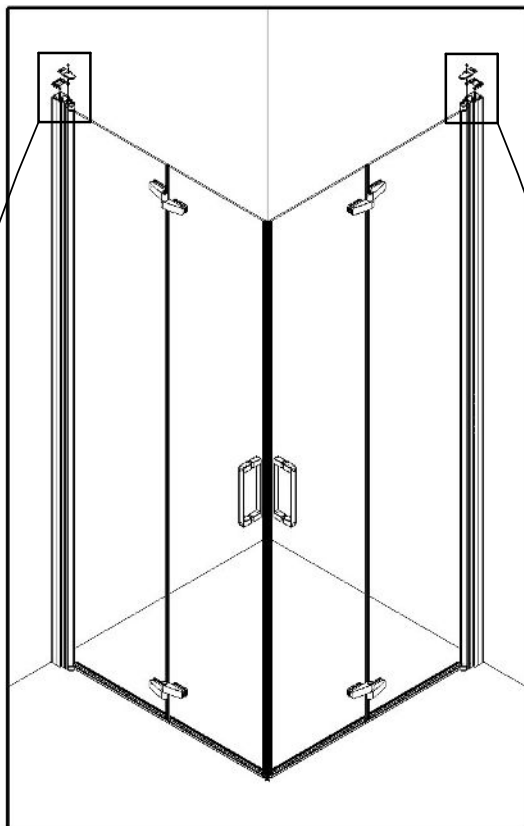

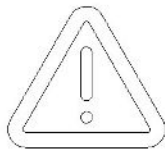

- Ⓕ Sens de montage
- Ⓖ Mounting direction
- Ⓔ Sentido de instalación
- Ⓛ Senso di montaggio
- Ⓜ Montagerichtung
- Ⓝ Montagerichtung

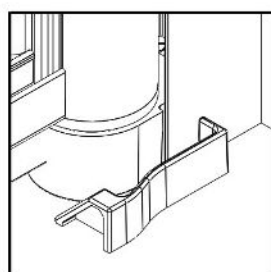
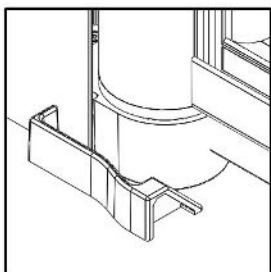
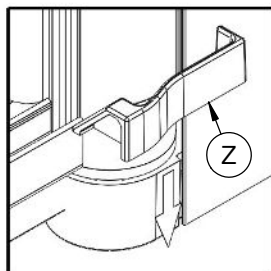
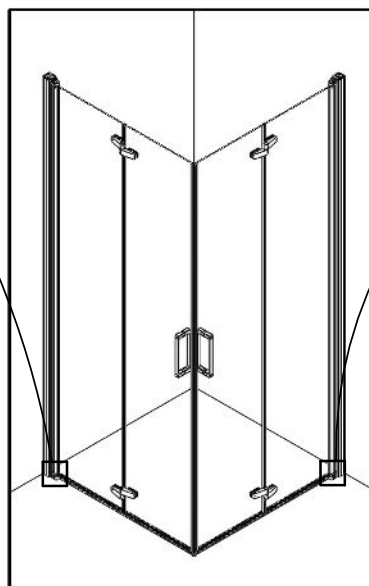
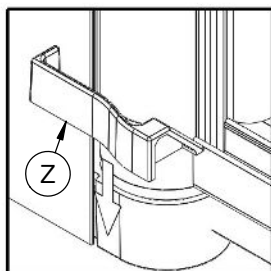
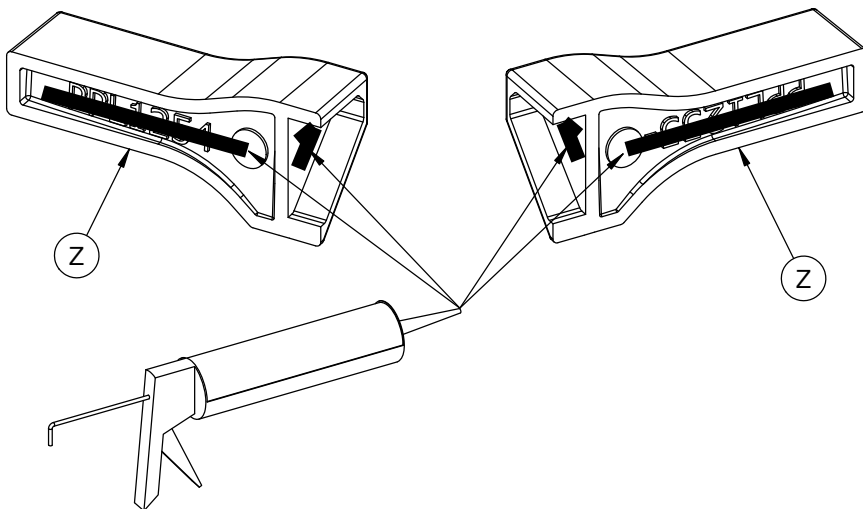

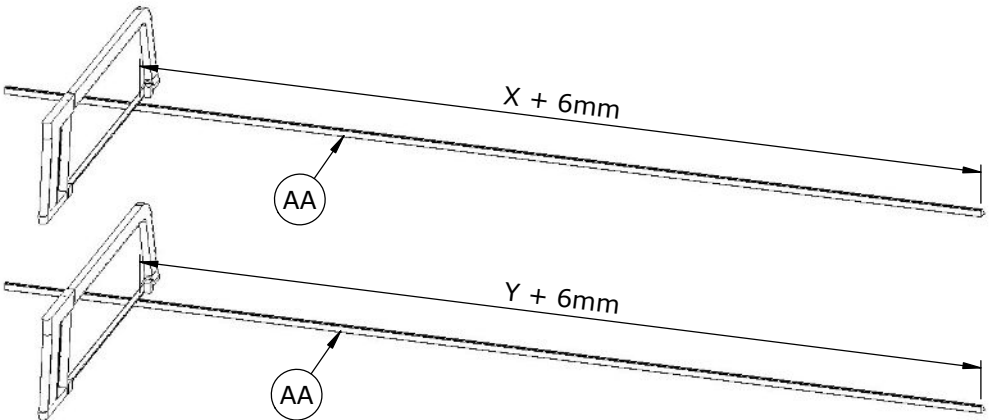
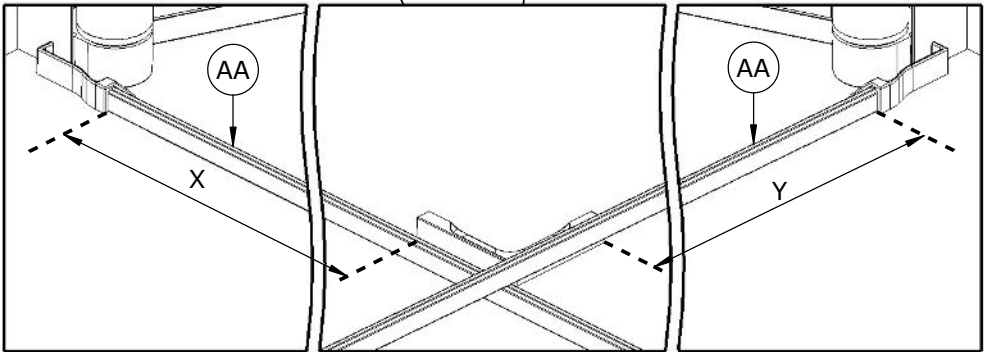
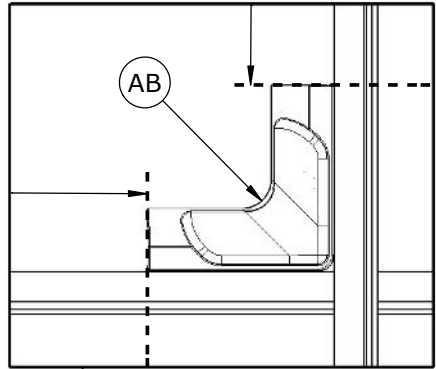
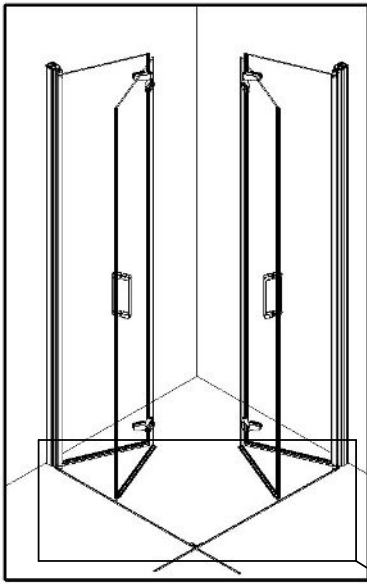

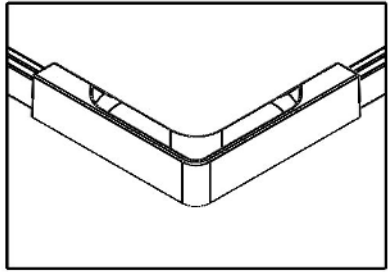
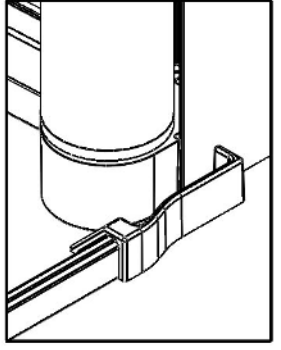
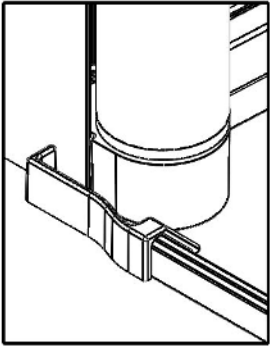
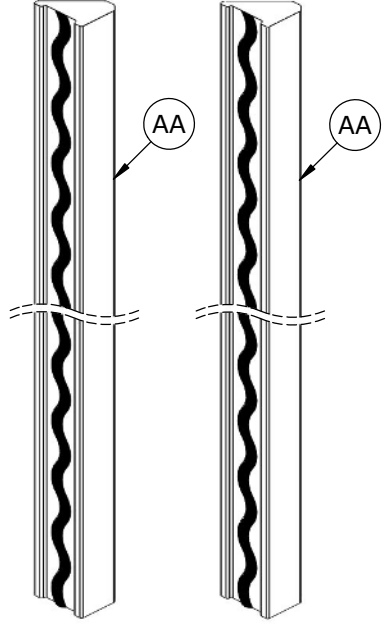
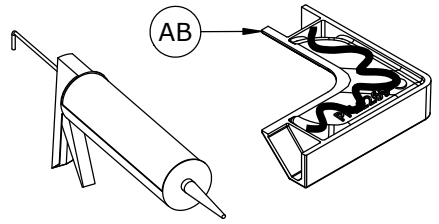
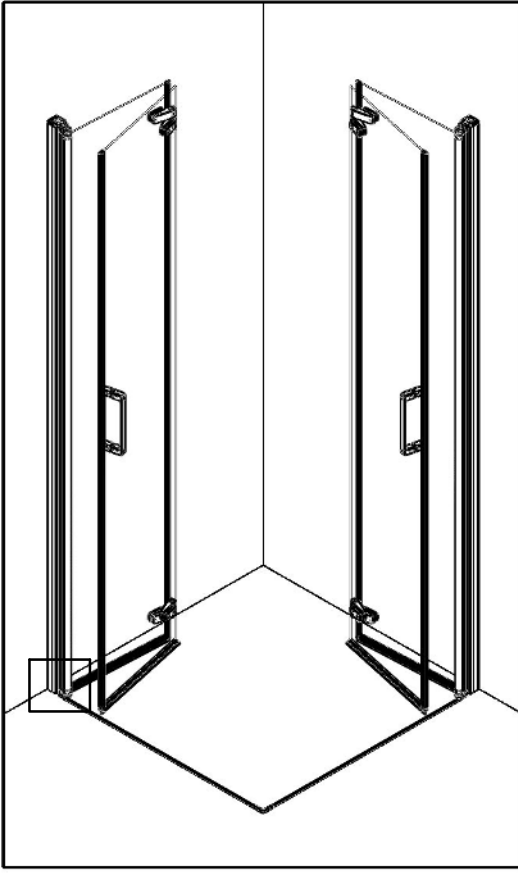

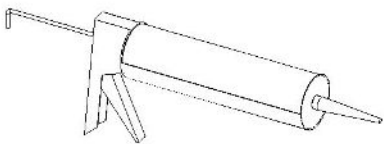

24H

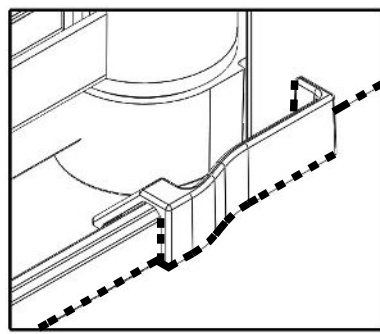
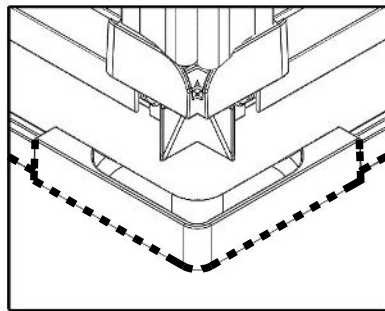
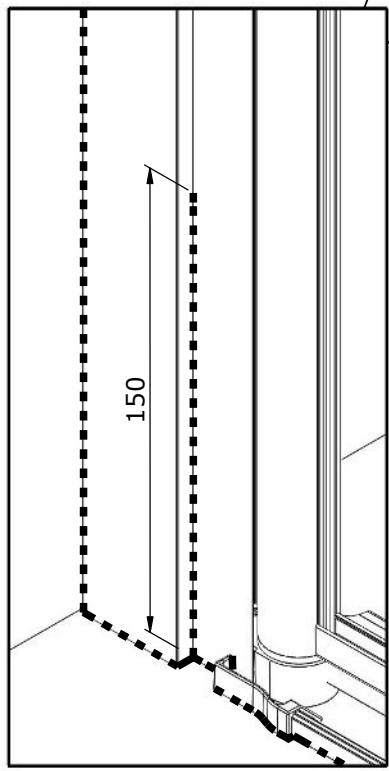
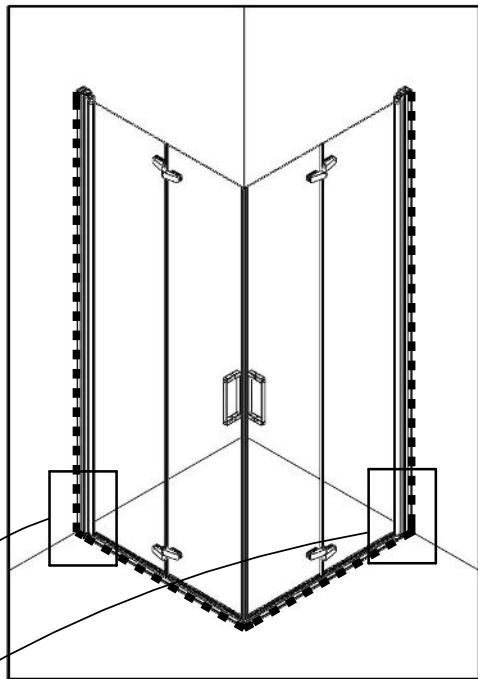

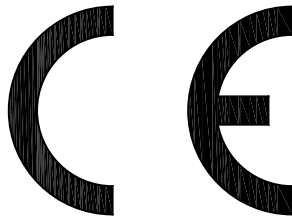

AQUAPRODUCTION, Site industriel,
F - 44680 Chaumes-en-Retz

18

EN 14428

Paroi de douche, fabriquée en verre de silicate
sodo-calcique de sécurité trempé thermiquement

Aptitude au nettoyage : réussite

Résistance à l'impact/propriétés de fragmentation : réussite

Durabilité : réussite



SAV
SERVICE HELPLINES
ASSISTENZA POST-VENDITA
SERVICIO POSTVENTA

FRANCE

02 40 21 29 45

SCHWEIZ

(01) 748 17 44

UK

020 8842 0033

ESPANA

93 544 60 76

IRELAND

04697 33102

NEDERLAND

+31 475 487 100

DEUTSCHLAND

+49 (0) 6074 / 30928 0

BELGIE

+31 475 487 100

ITALIA

(0382) 6181

BELGIQUE

+31 475 487 100

OSTEREICH

+43 1 710 60 70

РОССИЯ

963 19 40, 773 67 22