

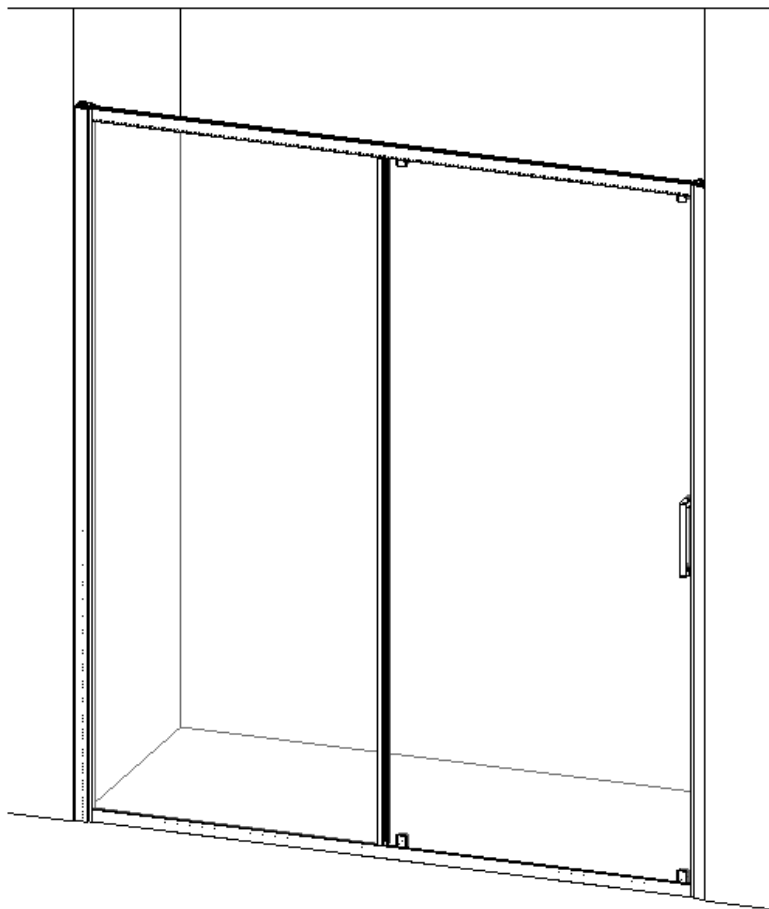

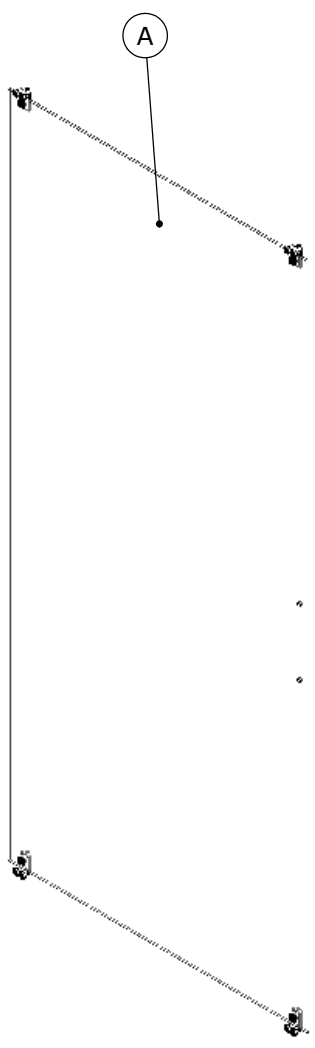



- F Notice de montage ● GB Installation instructions
- E Manual de instalación ● I Istruzioni di montaggio
- NL Montage-instructies ● D Montageanleitung

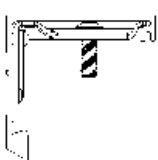
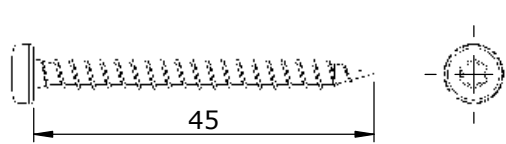

- F Attention aux étapes :
- GB Check installation steps :
- E Atención a los pasos :
- I Attenzione ai passi :
- NL Aandacht voor de stappen :
- D Achtung vor den Schritten :

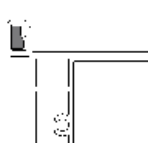
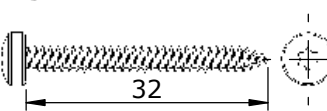
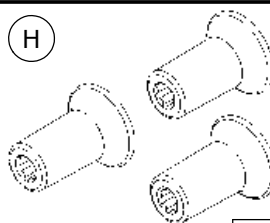
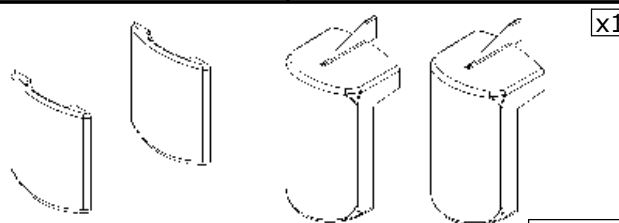
P.7 - 14 - 23

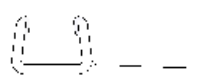
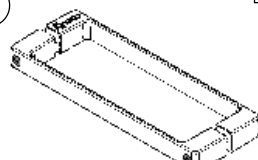
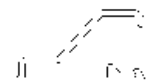
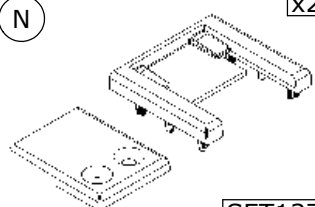
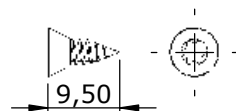

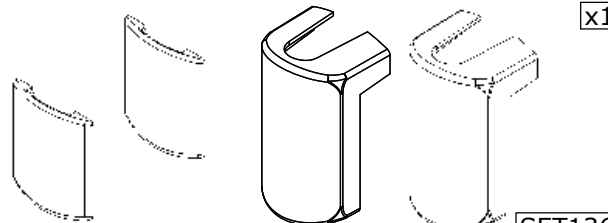
<p>C x2</p>  <p style="text-align: right;">6268</p>	<p>D Ø4 x6</p>  <p style="text-align: right;">VIS231</p>	
<p>E x6</p>  <p style="text-align: right;">CHE02</p>	<p>F x1</p>  <p style="text-align: right;">6279</p>	<p>G Ø3.5 x8</p>  <p style="text-align: right;">VIS214</p>
<p>H x2</p>  <p style="text-align: right;">SET134</p>	<p>I x1</p>  <p style="text-align: right;">SET135</p>	
<p>J x1</p>  <p>Lg=1952mm AI164</p>	<p>K x1</p>  <p>Lg=1950mm J802</p>	<p>L x1</p>  <p>Lg=950mm PGN49</p>
<p>M x2</p>  <p style="text-align: right;">6270</p>	<p>N x2</p>  <p style="text-align: right;">SET137</p>	<p>O Ø3.5 x2</p>  <p style="text-align: right;">VIS261</p>
<p>P x1</p>  <p>Lg=1926mm J793</p>	<p>Q x1</p>  <p style="text-align: right;">SET136</p>	

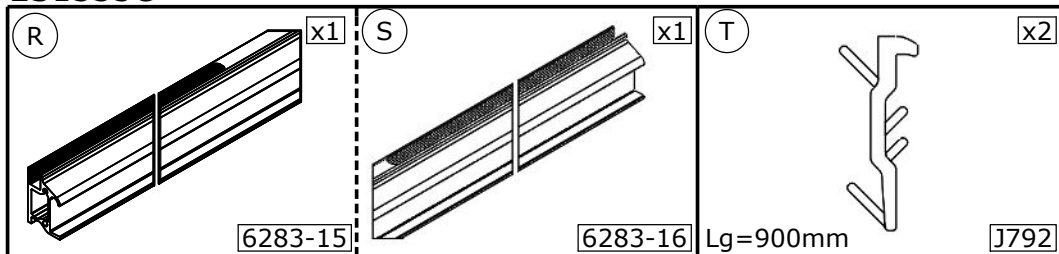

● Outillage nécessaire ● Tools required ● Equipamiento necesario
 ● Attrezzatura necessaria ● Benodigde gereedschap ● Werkzeuge erforderlich

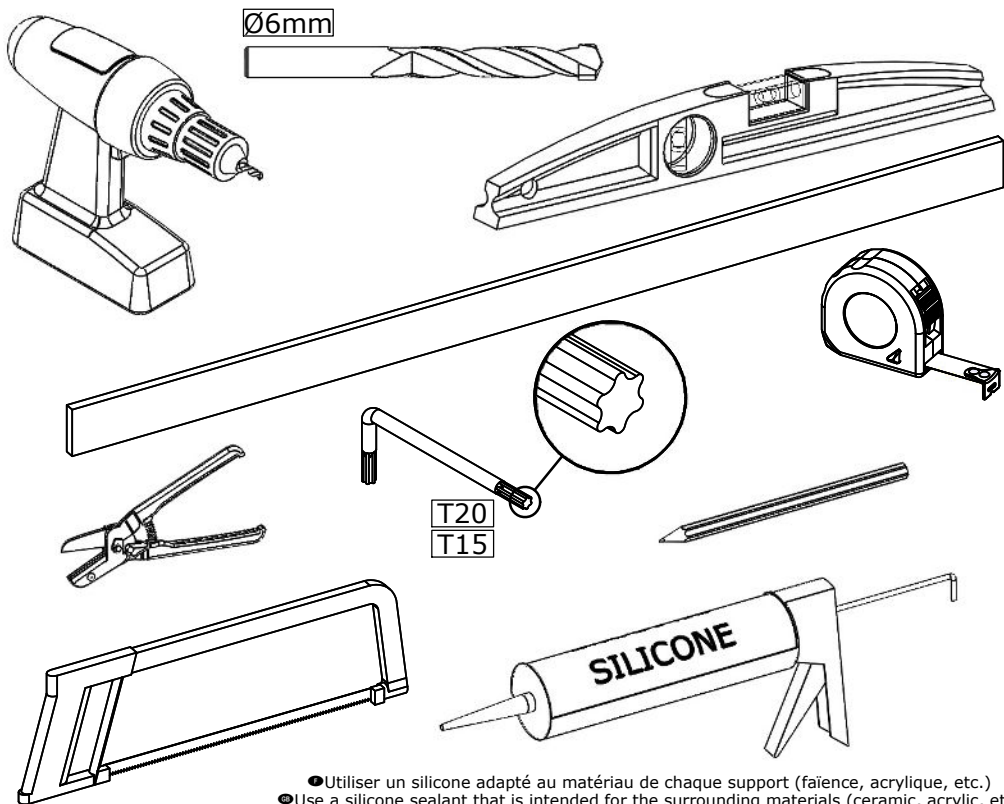

- Utiliser un silicone adapté au matériau de chaque support (faïence, acrylique, etc.)
- Use a silicone sealant that is intended for the surrounding materials (ceramic, acrylic, etc.)
- Usar una silicona adecuada para cada tipo de material (loza, acrílico, etc.)
- Utilizzare un silicone adatto a qualsiasi materiale (ceramica, acrilico, ecc.)
- Gebruik siliconenkit die geschikt is voor iedere ondergrond (tegelwerk, acryl, etc.)
- Für das jeweilige Trägermaterial (Stein, Acryl usw.) geeignetes Silikon verwenden.



● Réversibilité ● Reversibility ● Reversibilidad
● Reversibilida ● Omkeerbaarheid ● Wahlweise Montage

● Montage à gauche
● Left hand
● Montaje a la izquierda
● Montaggio a sinistra
● Montage links
● Montage links

● Montage à droite
● Right hand
● Montaje a la derecha
● Montaggio a destra
● Montage rechts
● Montage rechts

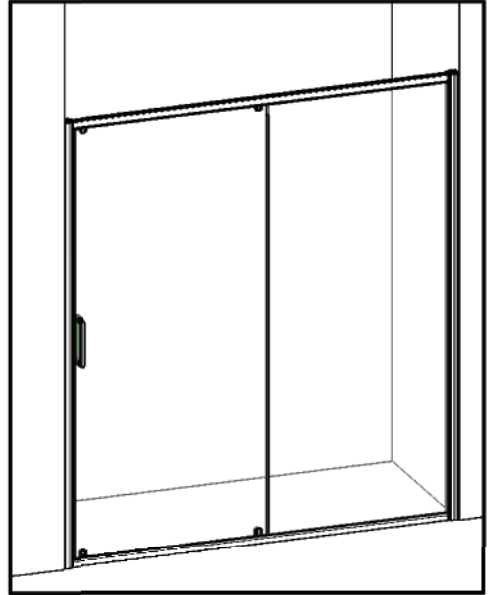
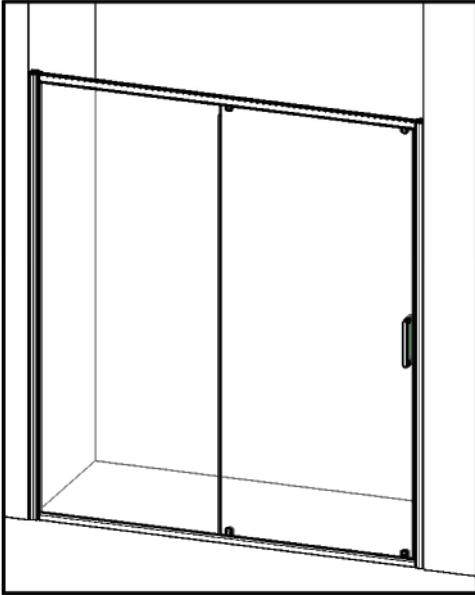

● Vous avez la possibilité de réaliser un montage à droite ou un montage à gauche. Notre notice d'installation décrit un montage à gauche. Si vous voulez réaliser un montage à droite, il vous suffit d'inverser le montage.

● This cubicle can be installed either left or right hand. These installation instructions show a left hand installation.

● Puede realizar un montaje a la derecha o un montaje a la izquierda. Nuestro folleto de instalación describe un montaje a la izquierda. Si desea montar su cabina a la derecha sólo tendrá que realizar el montaje al contrario.

● Avete la possibilità di effettuare il montaggio a destra o a sinistra. Il nostro manuale descrive il montaggio a sinistra. Se volete realizzare il montaggio a destra è sufficiente invertire varie fasi di montaggio.

● U kunt de douchebad rechts of links monteren. Onze handleiding beschrijft de links montage van de bad. Keer de montage om als u de bad rechts wilt monteren.

● Sie haben die Möglichkeit, eine Montage auf der linken Seite oder eine Montage auf der rechten Seite durchzuführen. Unsere Montageanleitung beschreibt eine Montage auf der linken Seite. Wenn Sie die Montage lieber auf der rechten Seite durchführen wollen, müssen Sie nur den Montageprozess umkehren.

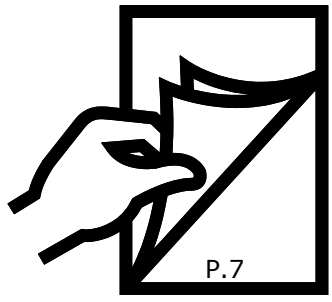
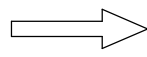
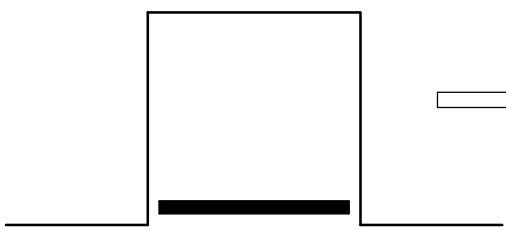
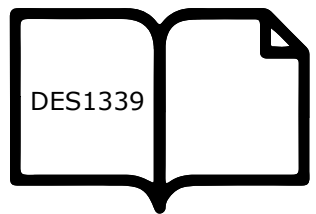
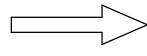
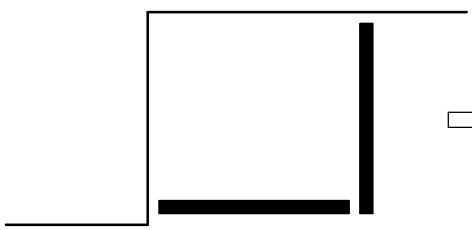
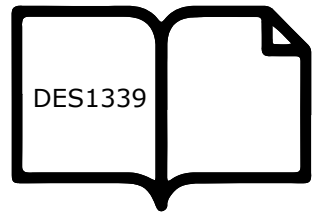
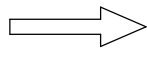
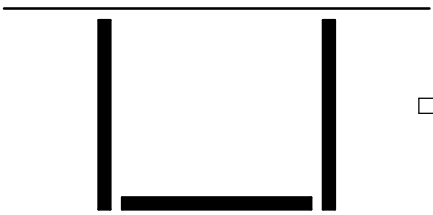

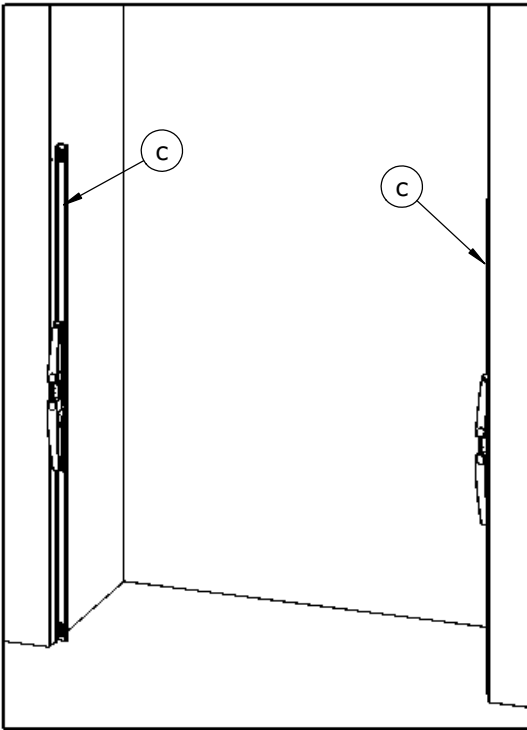

- Si receveur ● If shower tray
- Si plato ● Se piatto
- Als douchebak
- Wenn Duschwanne

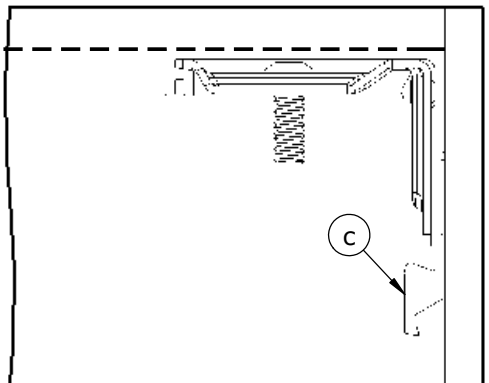
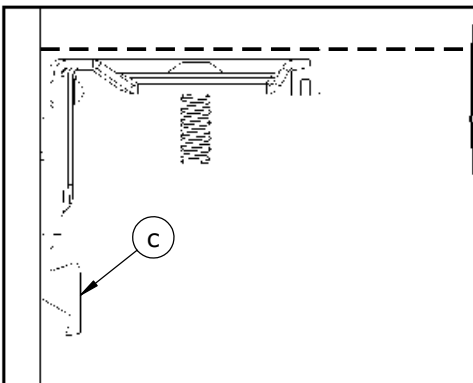
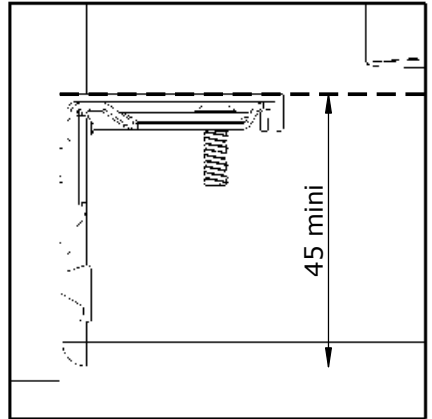

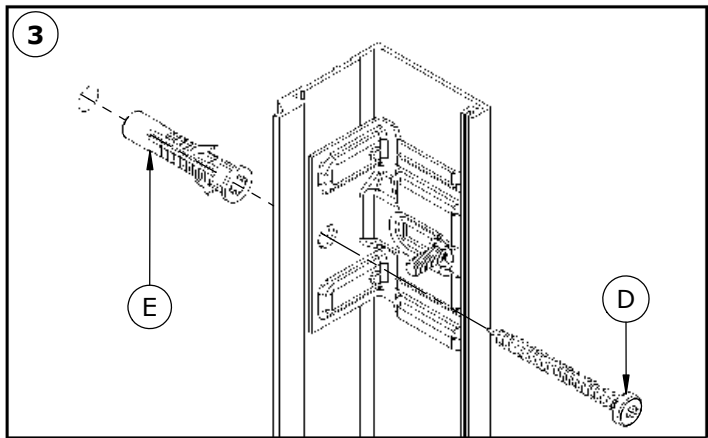
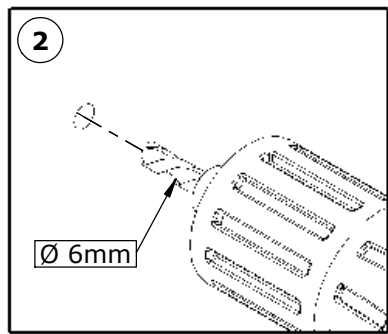
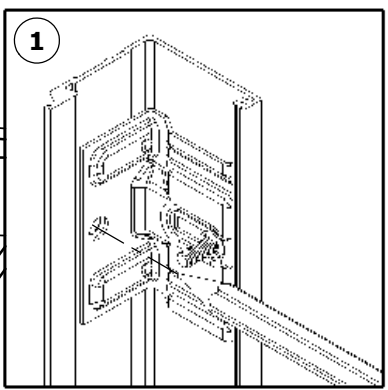
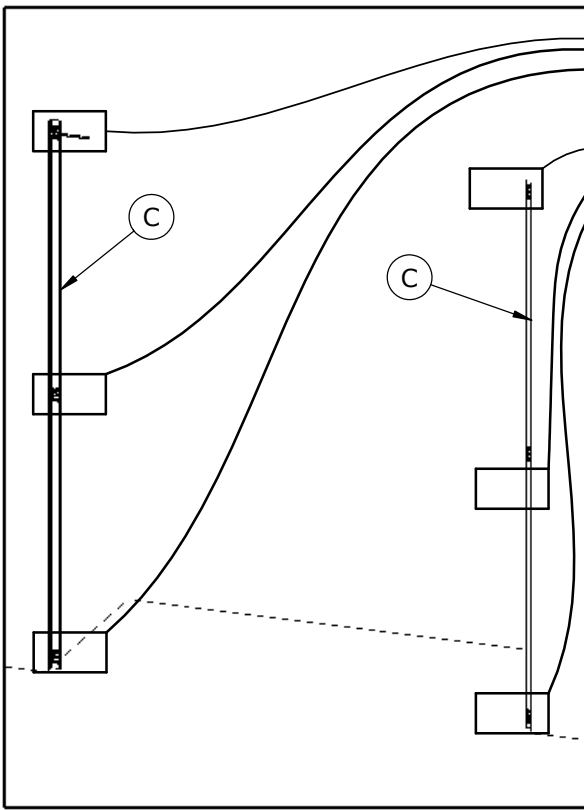

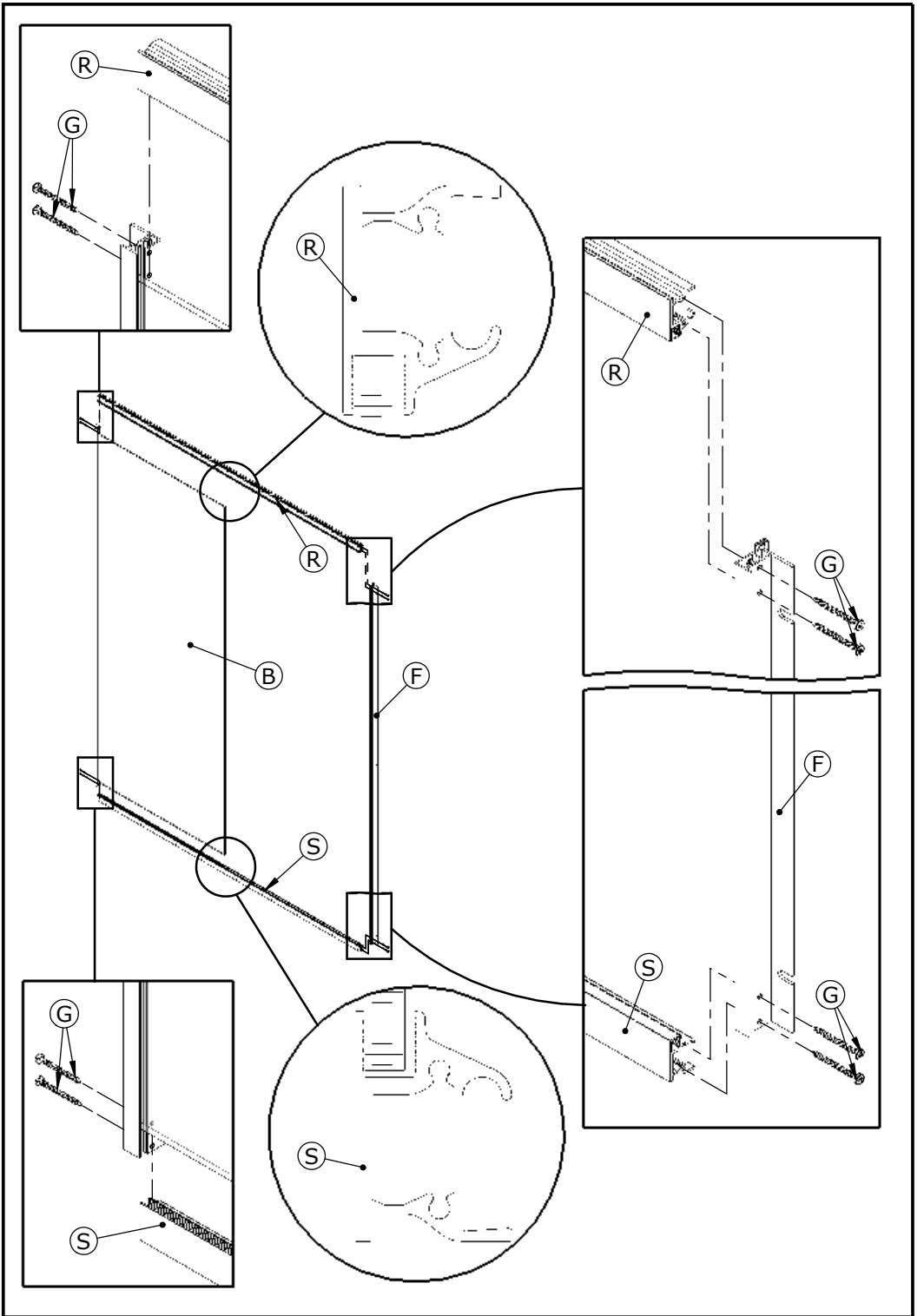

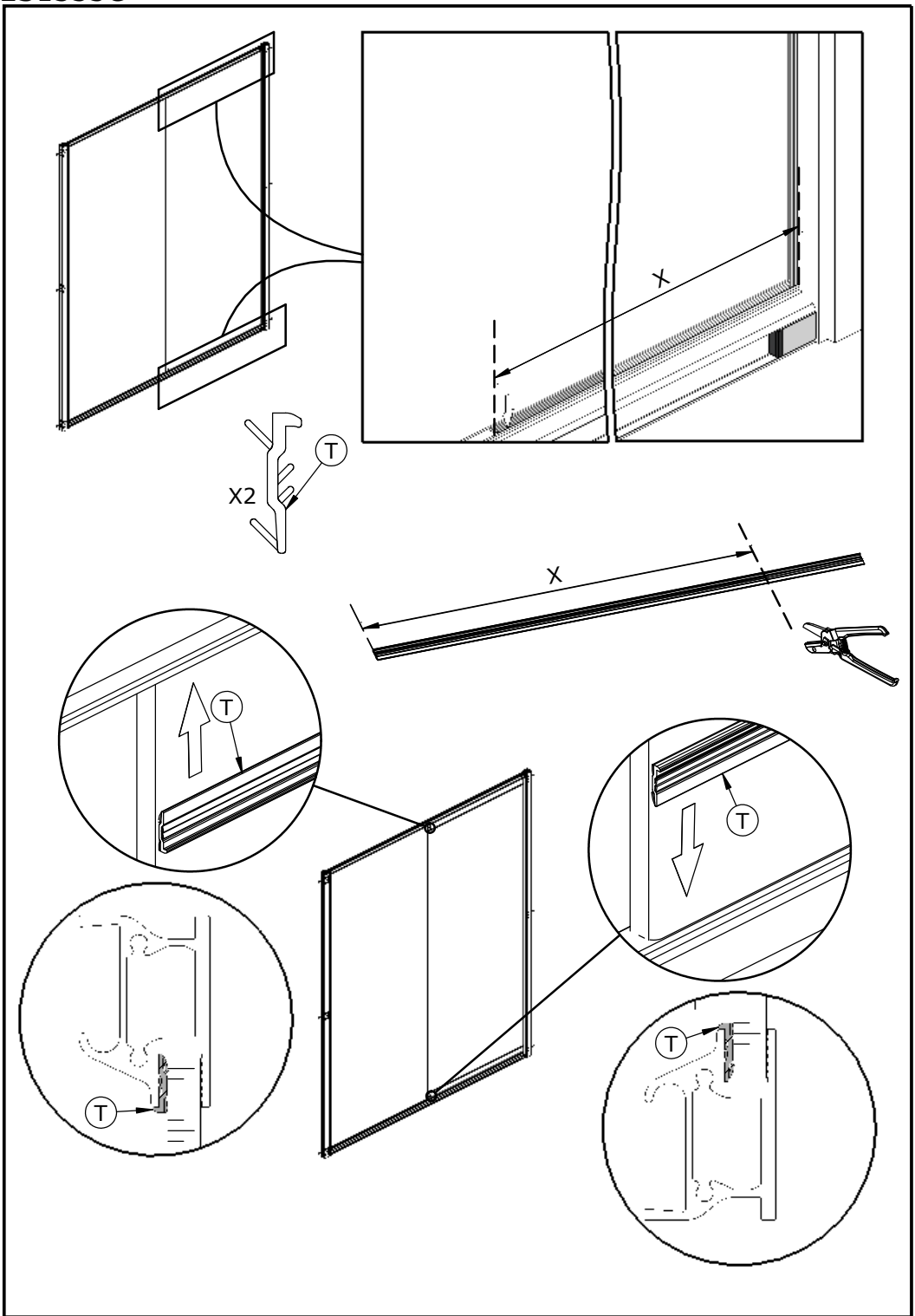

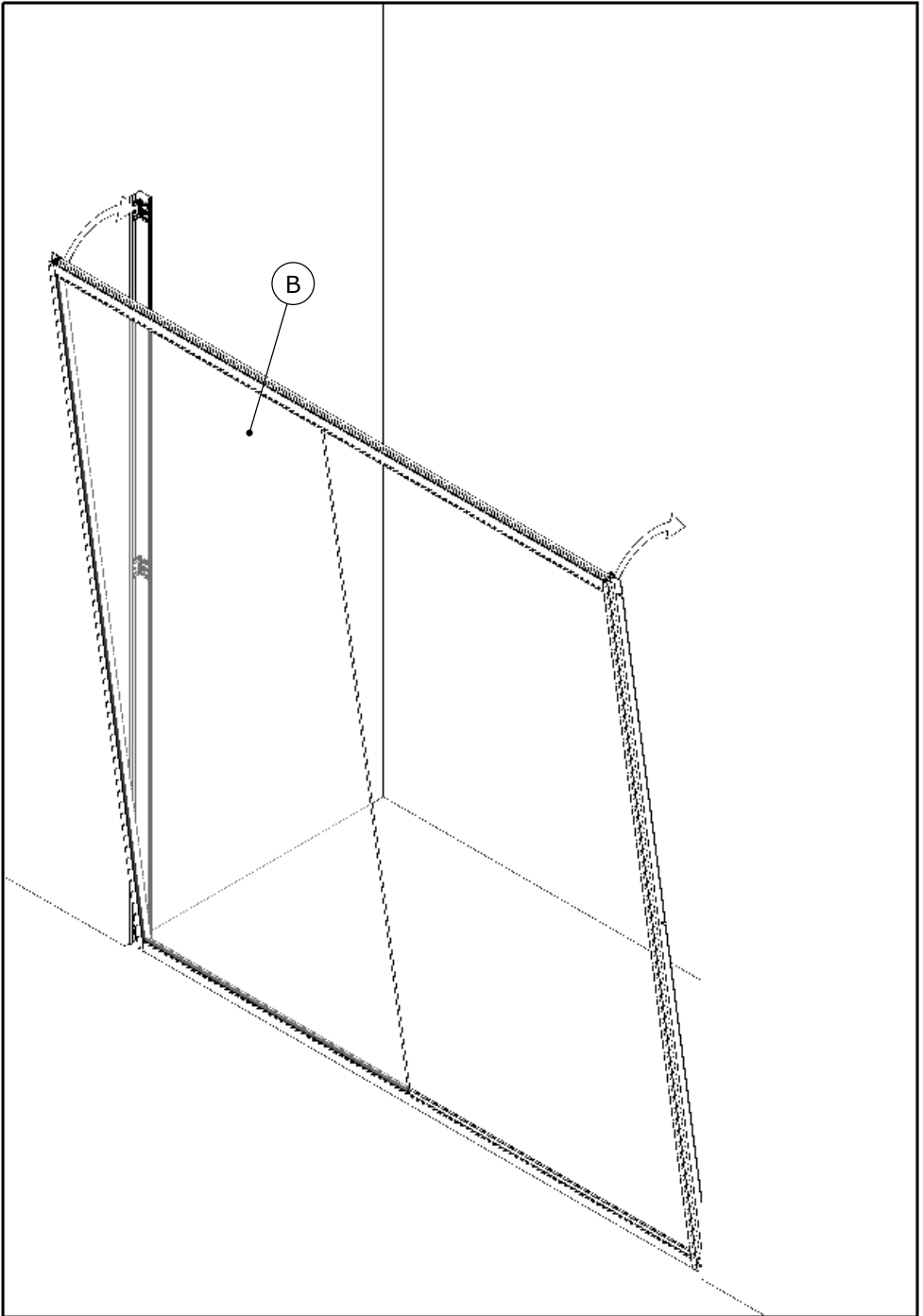

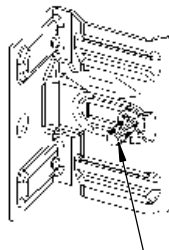
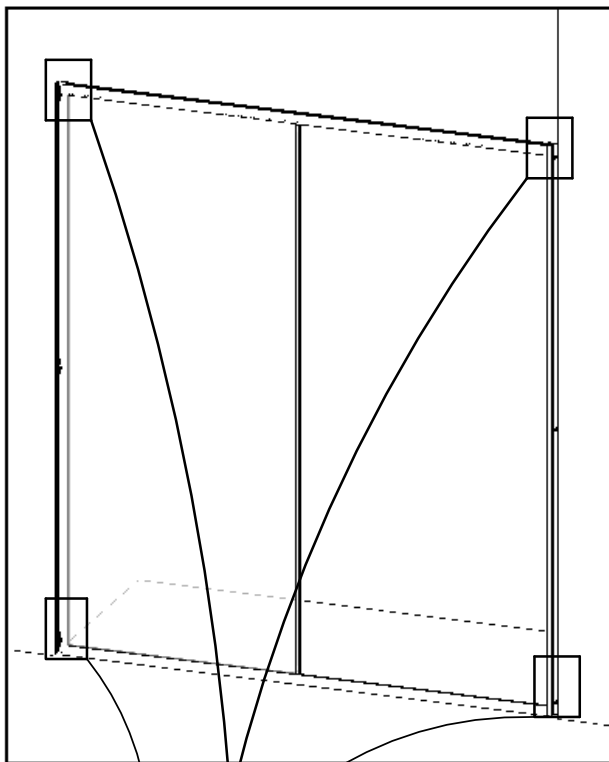

- Si nécessaire, desserrer, régler puis resserrer
- If necessary, loosen, adjust and retighten
- Si es necesario, afloje, ajuste y apriete
- Se necessario, allentare, regolare e stringere
- Draai los, indien nodig, stel af en draai vervolgens weer vast
- Falls erforderlich, lösen, einstellen und wieder festziehen

H



- F Serrer
- BB Tighten
- E Apriete
- I Serrare
- NL Vastdraaien
- D Festziehen

X4

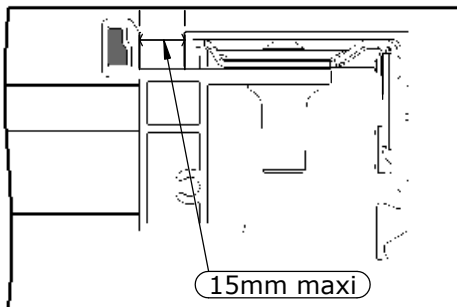
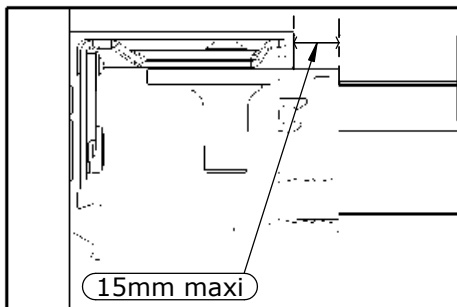
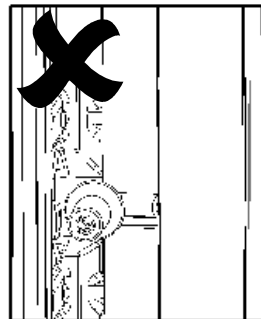
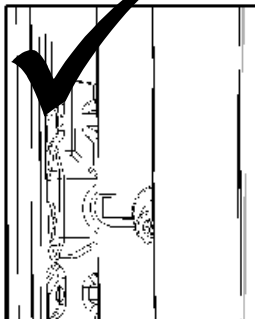
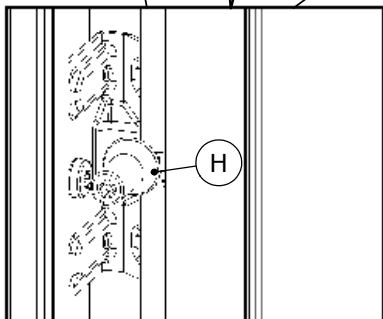

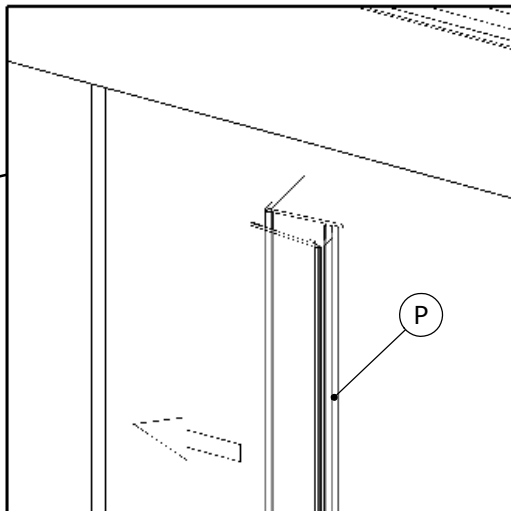
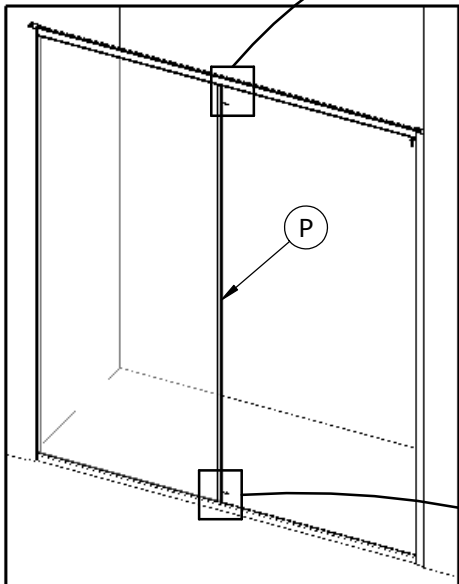

● Extérieur ● Outside ● Exterior
 ● Esterno ● Buitenkant ● Außen

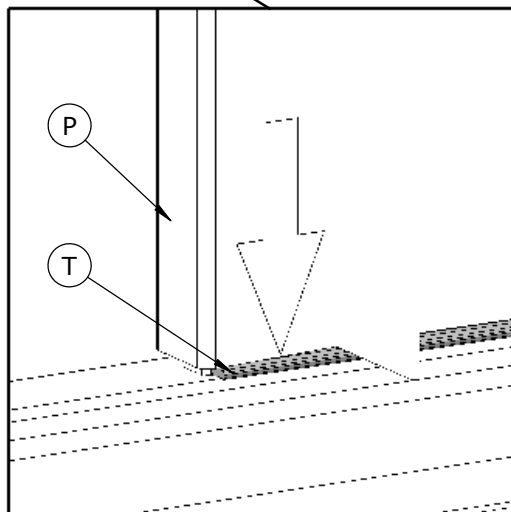
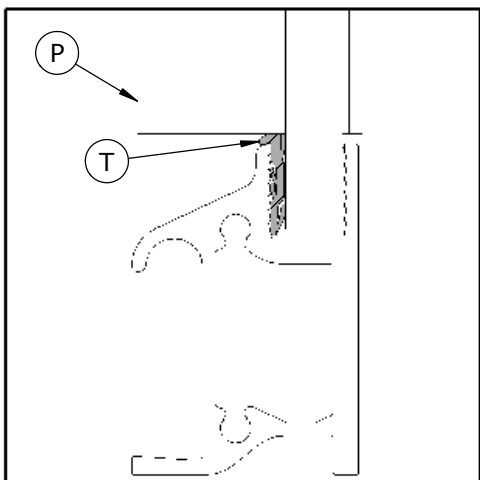

● Intérieur ● Inside ● Interior
 ● Interno ● Binnenkant ● Innen

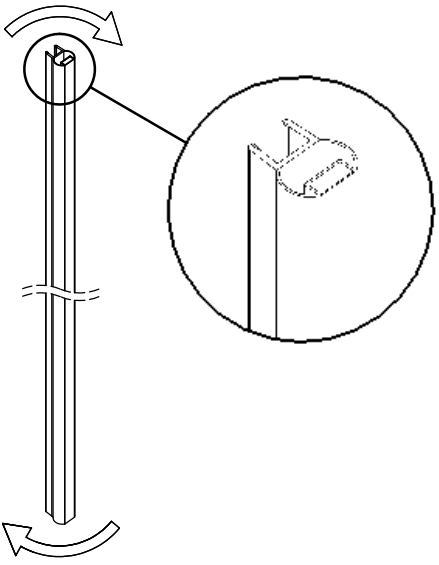
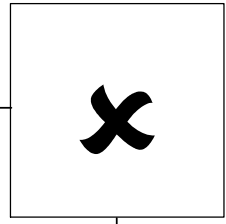
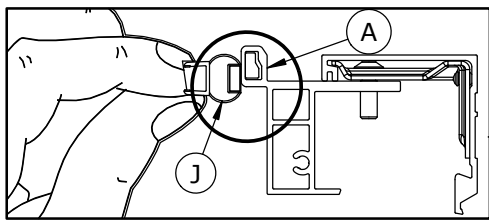
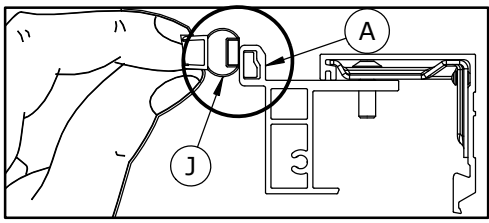
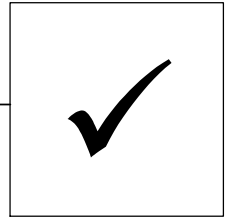
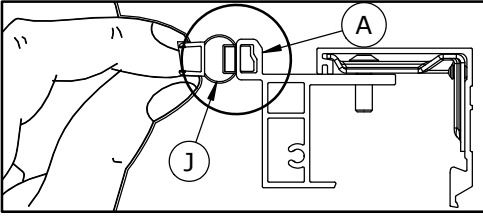

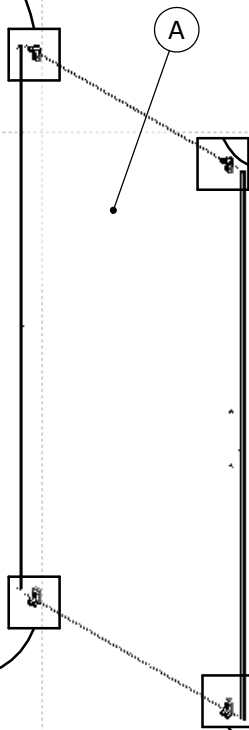
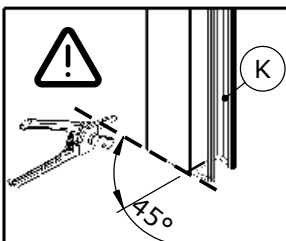
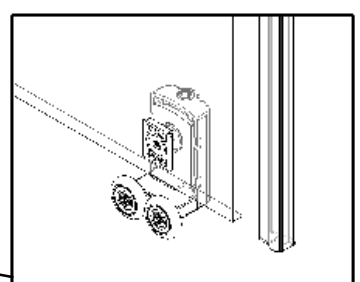
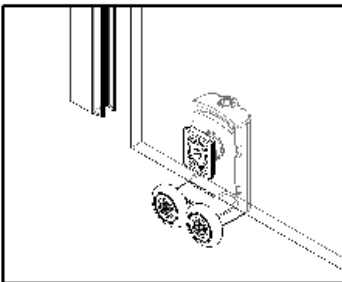
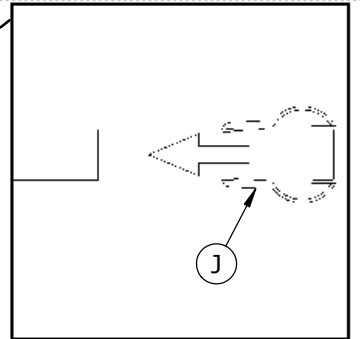
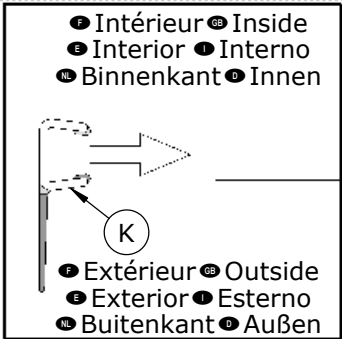
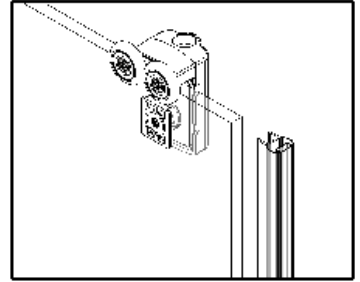
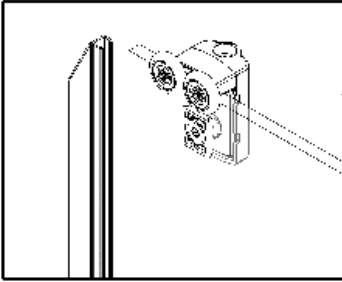
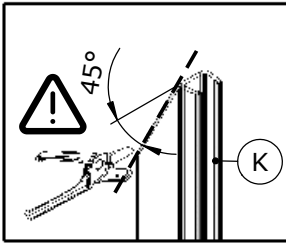

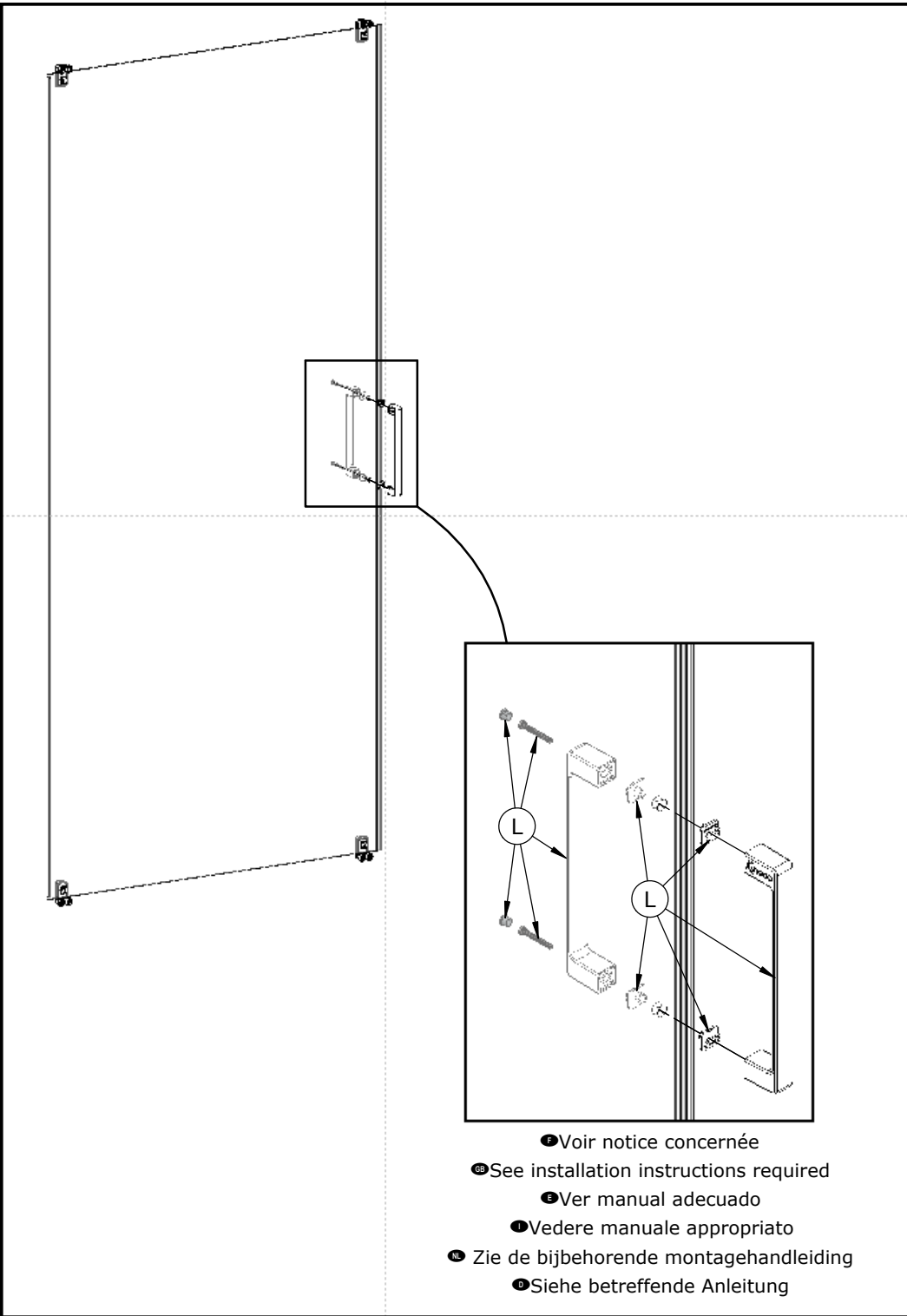

● Voir notice concernée

● See installation instructions required

● Ver manual adecuado

● Vedere manuale appropriato

● Zie de bijbehorende montagehandleiding

● Siehe betreffende Anleitung

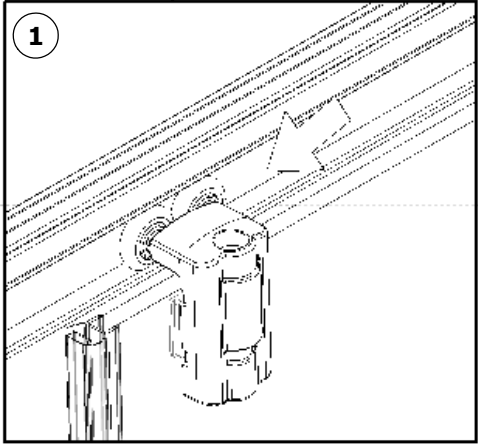
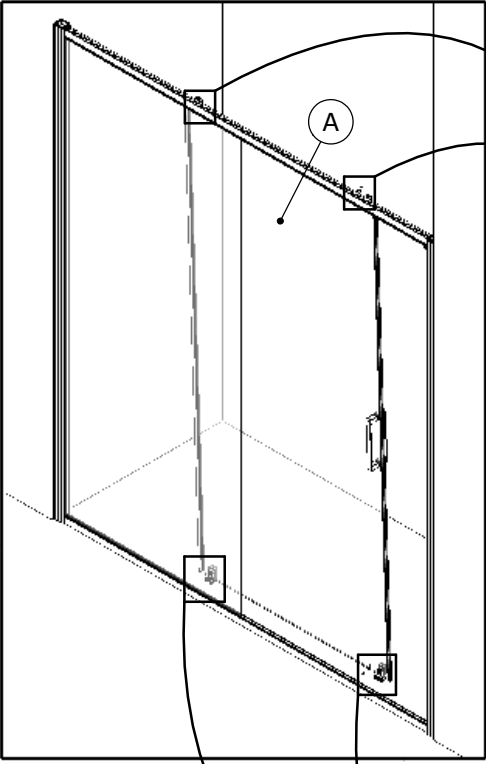

● Intérieur ● Inside ● Interior
● Interno ● Binnenkant ● Innen

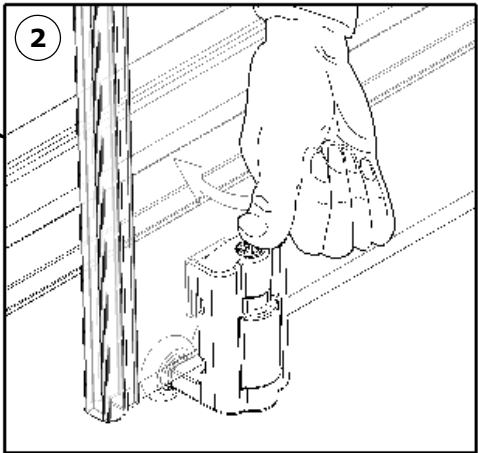

- Régler les portes afin qu'elles soient de niveau
- Adjust the doors so that they are level
- Ajustar las puertas de manera que estén niveladas
- Regolare le porte in modo che siano in bolla
- Stel de deuren zodanig af zodat ze waterpas staan
- Türen waagrecht ausrichten

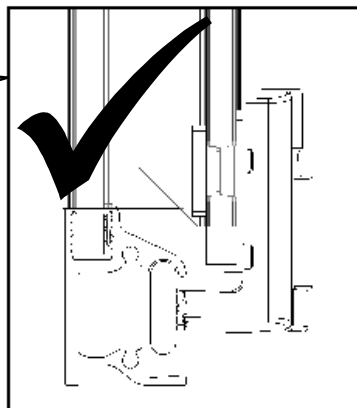
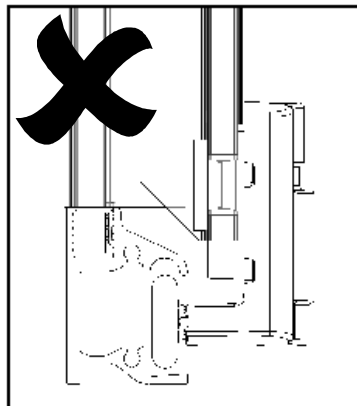
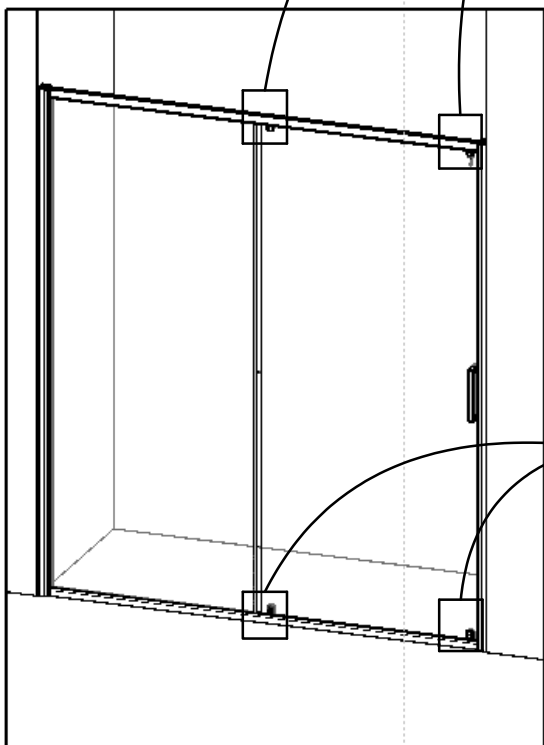
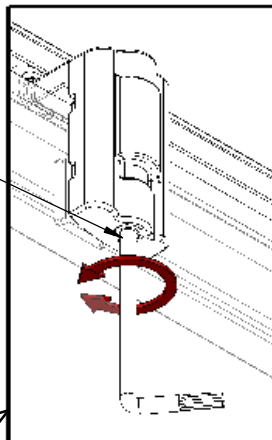

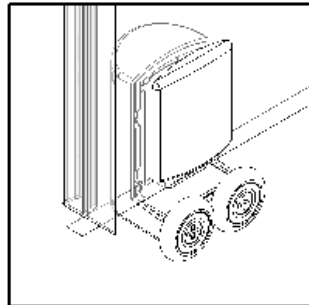
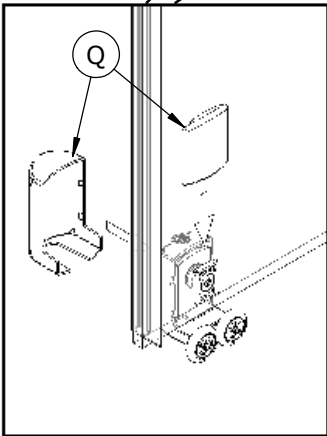
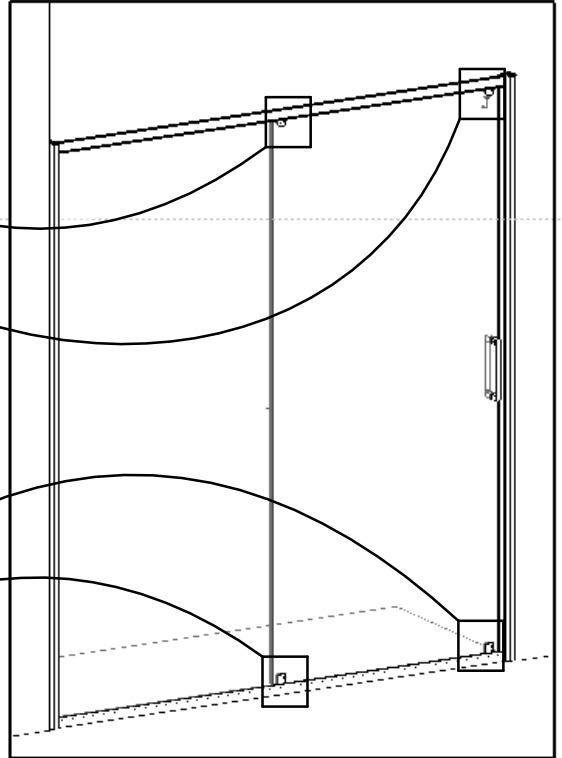
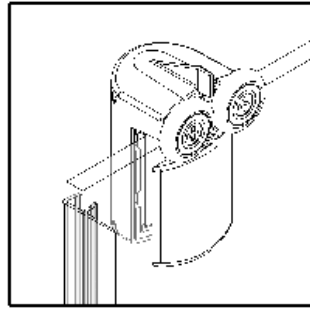
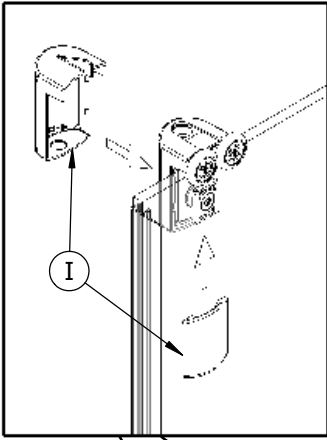

X2

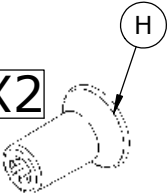

- F Serrer
- GB Tighten
- E Apriete
- I Serrare
- NL Vastdraaien
- D Festziehen

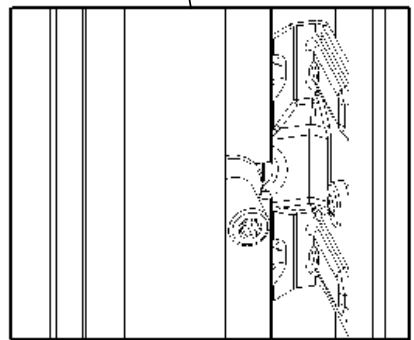
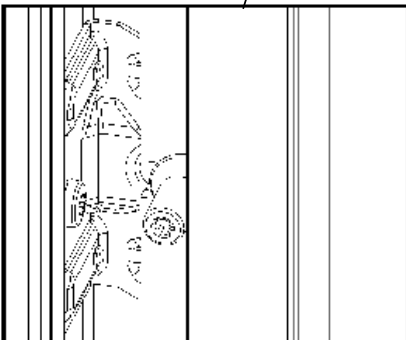
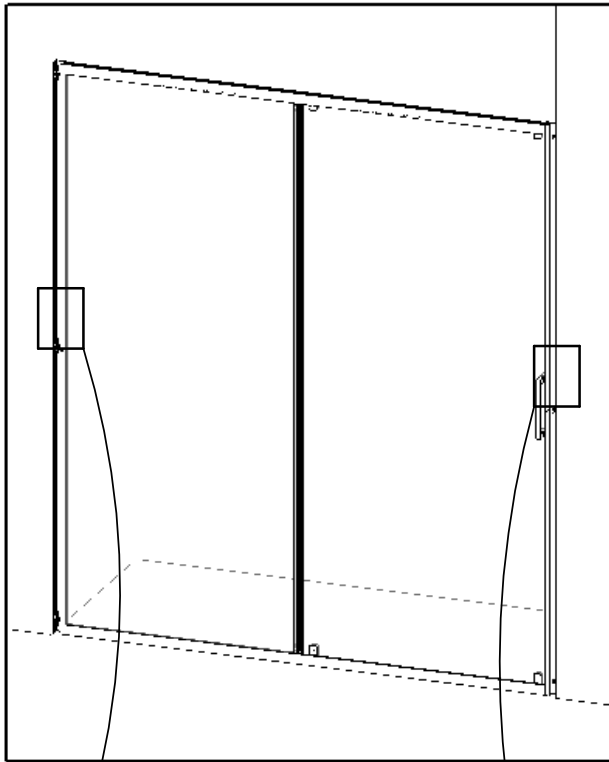

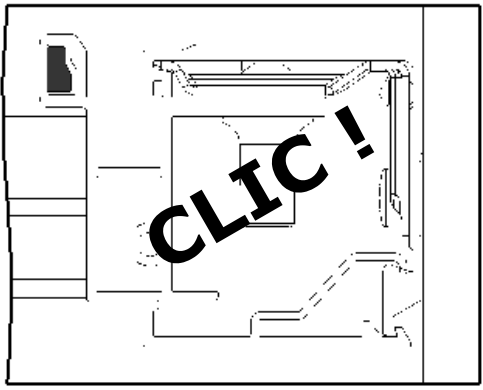
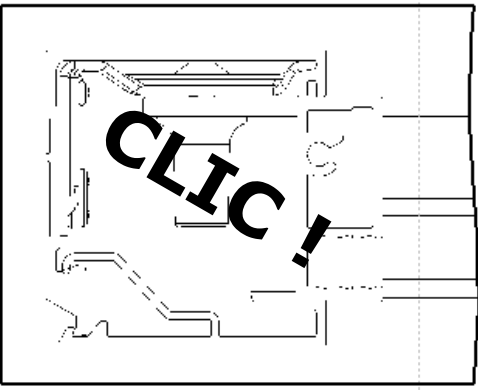
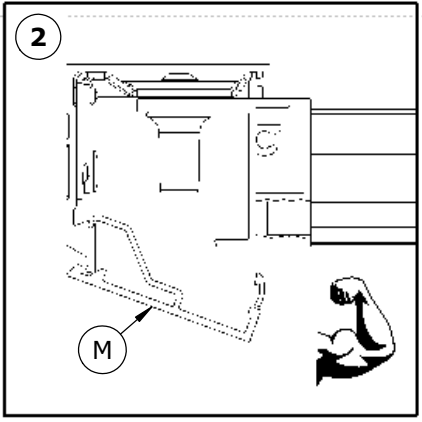
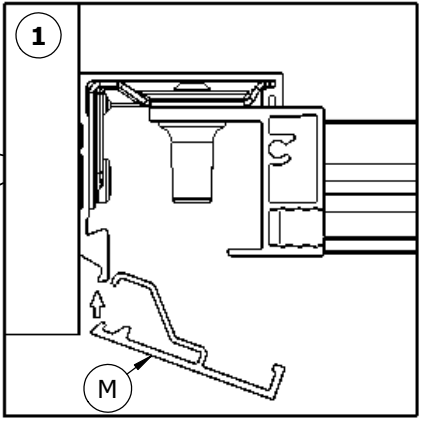
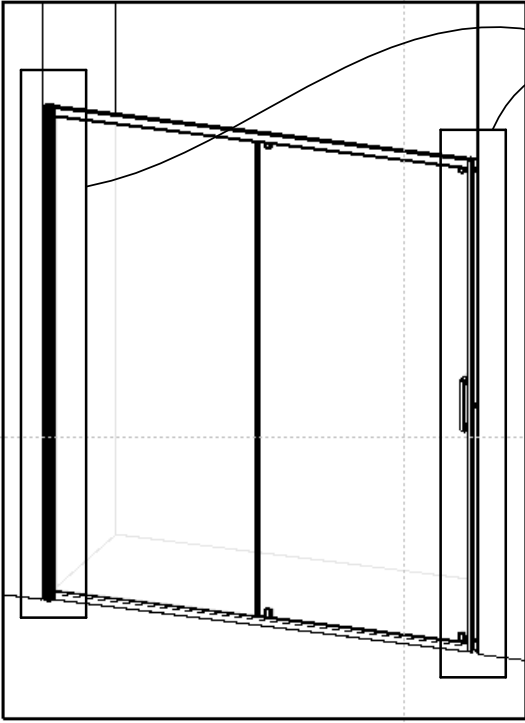

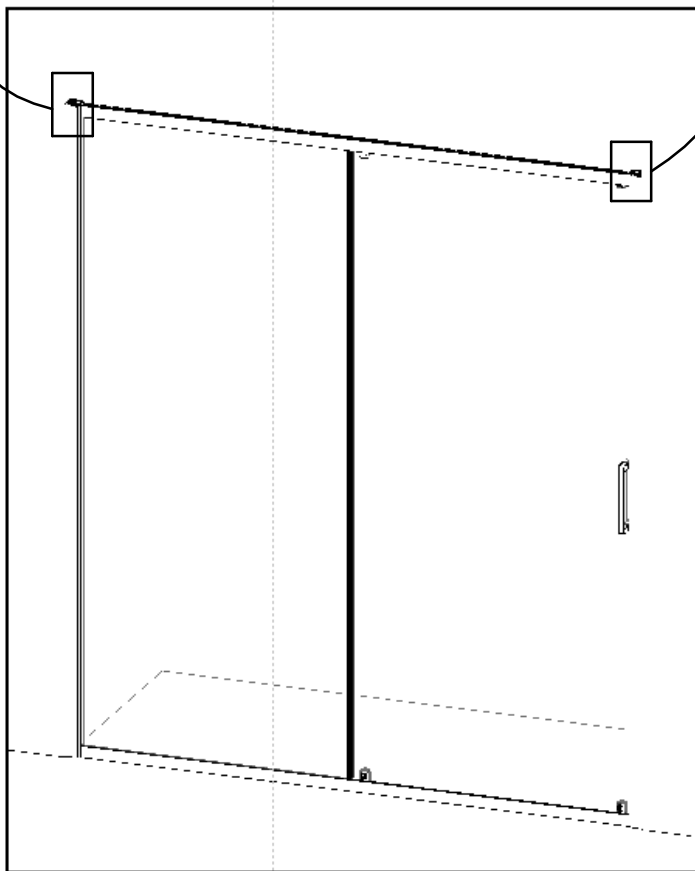
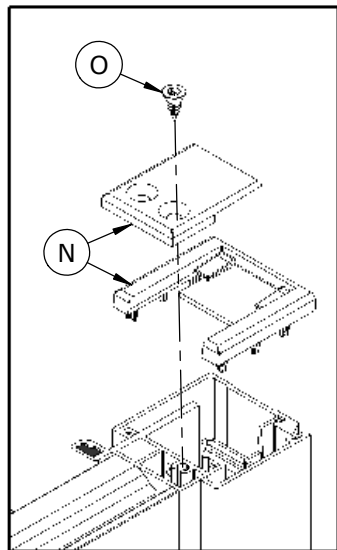
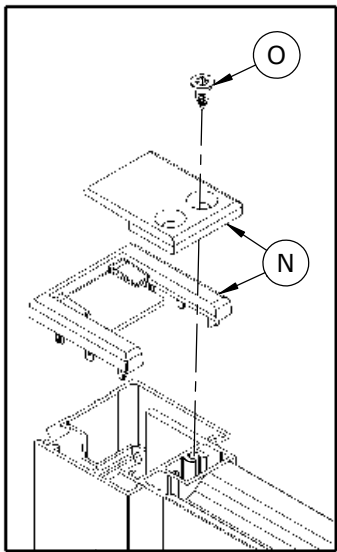

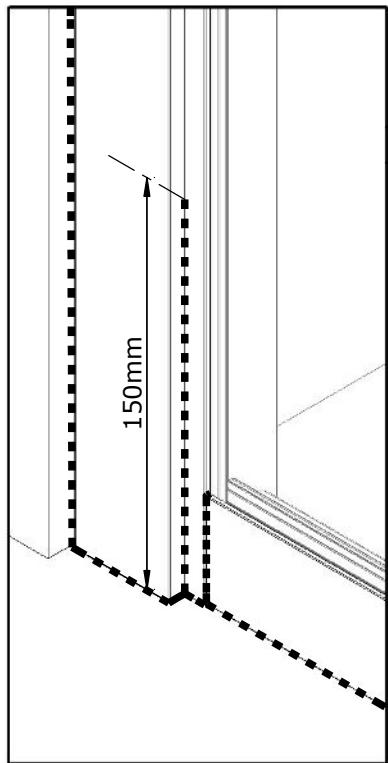
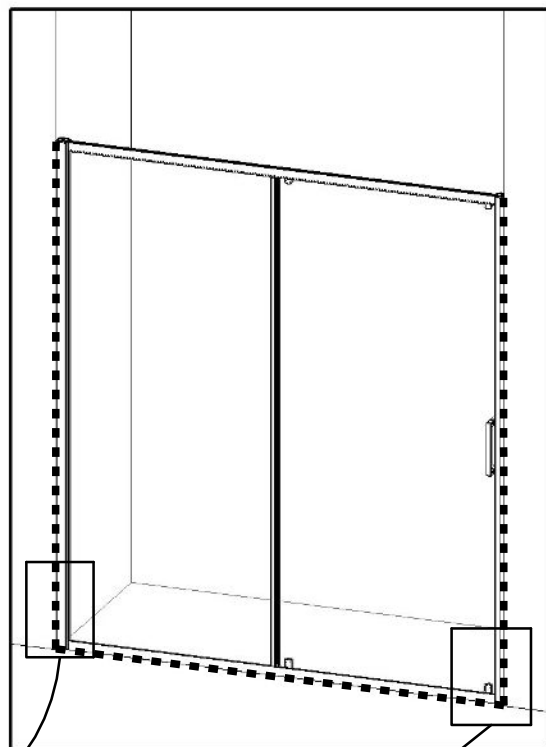
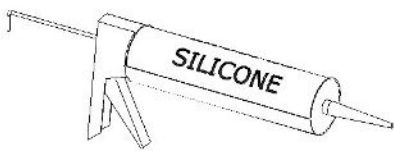

24H



SAV
SERVICE HELPLINES
ASSISTENZA POST-VENTITA
SERVICIO POSTVENTA

FRANCE

02 40 21 29 45

UK

020 8842 0033

IRELAND

04697 33102

DEUTSCHLAND

+49 (0) 6074 / 30928 0

ITALIA

(0382) 6181

OSTEREICH

+43 1 710 60 70

SCHWEIZ

(01) 748 17 44

ESPANA

93 544 60 76

NEDERLAND

+31 475 487 100

BELGIE

+31 475 487 100

BELGIQUE

+31 475 487 100

РОССИЯ

963 19 40, 773 67 22



AQUAPRODUCTION, Site industriel,
 F - 44680 Chaumes-en-Retz

18

EN 14428

Paroi de douche, fabriquée en verre de silicate
 sodo-calcique de sécurité trempé thermiquement

Aptitude au nettoyage : réussite

Résistance à l'impact/propriétés de fragmentation : réussite

Durabilité : réussite