

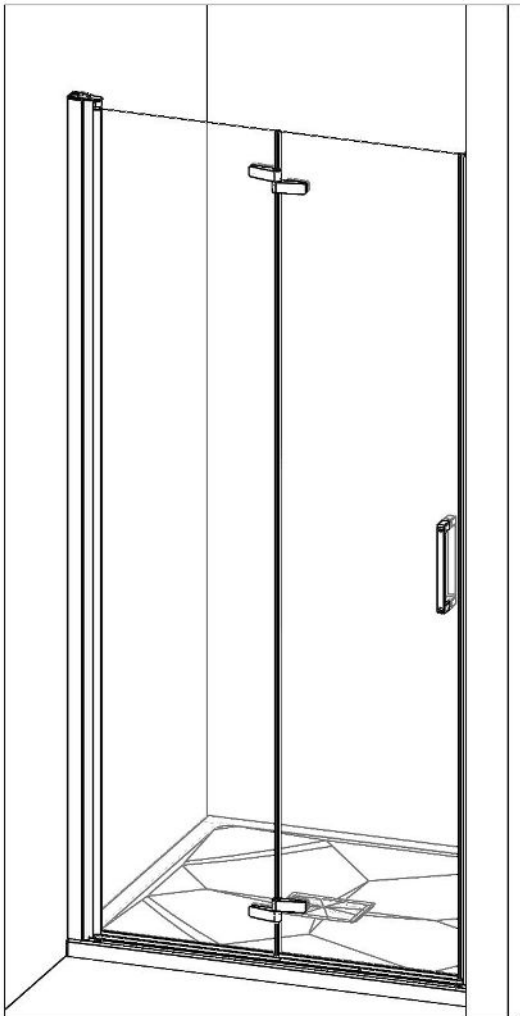

- F NOTICE DE MONTAGE
- GB INSTALLATION INSTRUCTIONS
- I ISTRUZIONI DI MONTAGGIO
- NL INSTALLATIE VOORSCHRIFTEN
- D INSTALLATIONSANLEITUNG





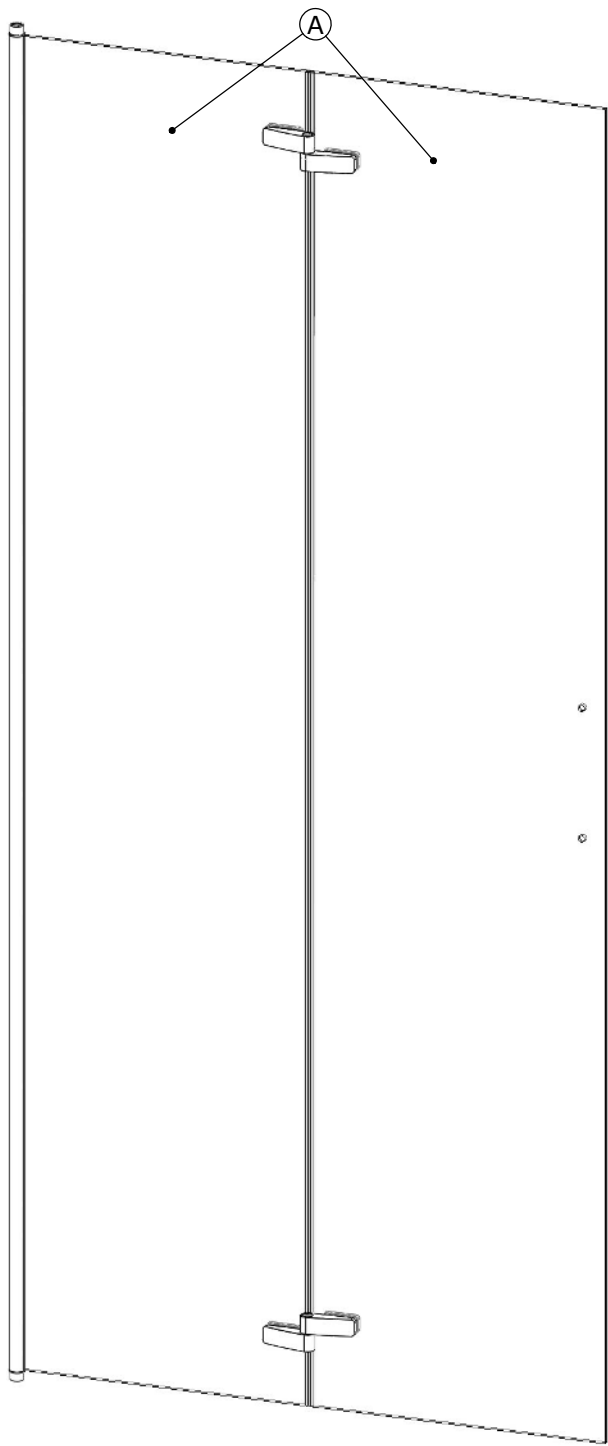

- Attention aux étapes :
- Check installation steps :
- Attenzione ai passi :
- Aandacht voor de stappen :
- Achtung vor den Schritten :

P. 6 - 11 - 28

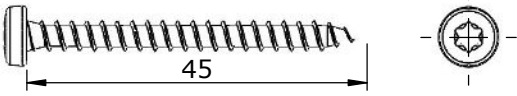

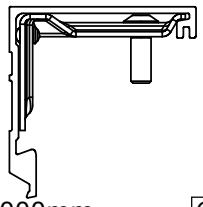
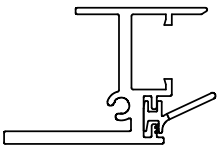
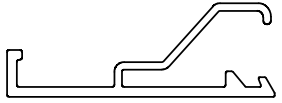
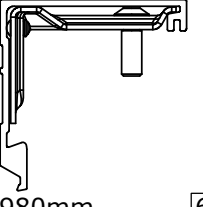
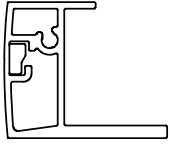
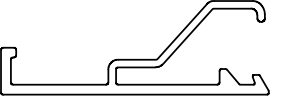
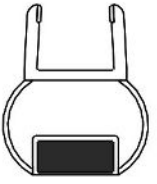
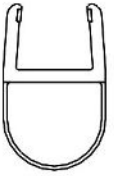
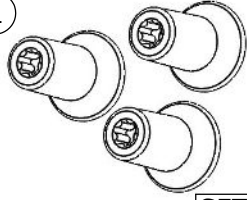
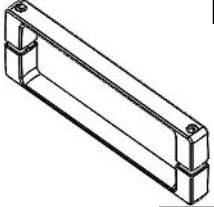
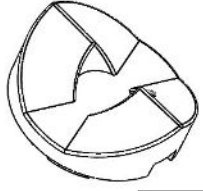
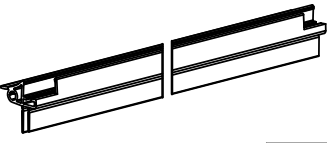
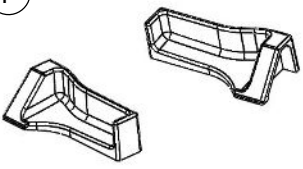
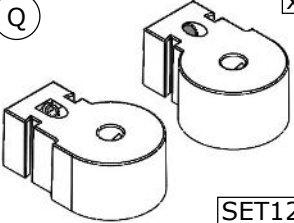
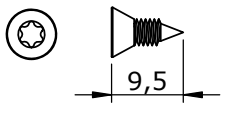
<p>B $\varnothing 3.5\text{mm}$ x6</p>  <p style="text-align: center;">45</p> <p style="text-align: right;">VIS231</p>	<p>C x6</p>  <p style="text-align: right;">CHE02</p>	
<p>D x1</p>  <p>Lg=2000mm 6268</p>	<p>E x1</p>  <p>Lg=2000mm 6272</p>	<p>F x1</p>  <p>Lg=2000mm 6270</p>
<p>G x1</p>  <p>Lg=1980mm 6268</p>	<p>H x1</p>  <p>Lg=1980mm 6273</p>	<p>I x1</p>  <p>Lg=1980mm 6270</p>
<p>J x1</p>  <p>Lg=1962mm AI178</p>	<p>K x1</p>  <p>Lg=1962mm J808</p>	<p>L x2</p>  <p style="text-align: right;">SET134</p>
<p>M x1</p>  <p style="text-align: right;">PGN49</p>	<p>N x1</p>  <p style="text-align: right;">PPL1248</p>	<p>O x2</p>  <p style="text-align: right;">J806</p>
<p>P x1</p>  <p style="text-align: right;">SET140</p>	<p>Q x1</p>  <p style="text-align: right;">SET128</p>	<p>R $\varnothing 3.5\text{mm}$ x2</p>  <p style="text-align: center;">9,5</p> <p style="text-align: right;">VIS261</p>

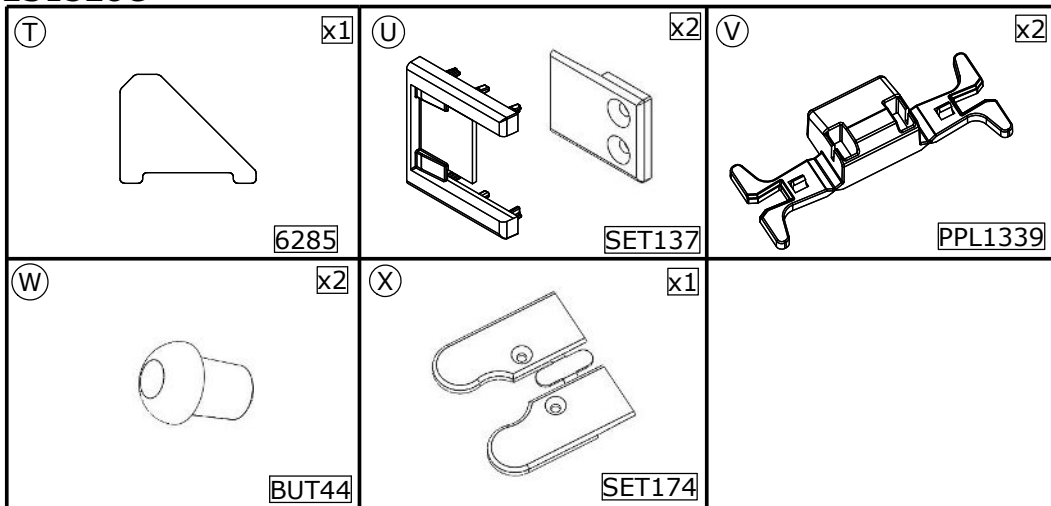

- Les quantités données sont les quantités utiles au montage. les sachets fournis contiennent des pièces supplémentaires.
- The quantities given are what are required for the installation. There may be some surplus in the package provide.
- Le quantità fornite sono le quantità necessarie al montaggio. I sacchetti forniti contengono pezzi supplementari.
- De aangegeven aantallen zijn vereist voor de montage. De verpakking bevat extra onderdelen.
- Die Mengenangaben beziehen sich auf die für die Montage nötigen Teile. Eventuell weitere beige packte Teile ignorieren.

Ⓣ Matériel nécessaire Ⓢ Tools required

Ⓢ Materiale necessario Ⓢ Benodigd gereedschap Ⓢ Benötigte Werkzeuge

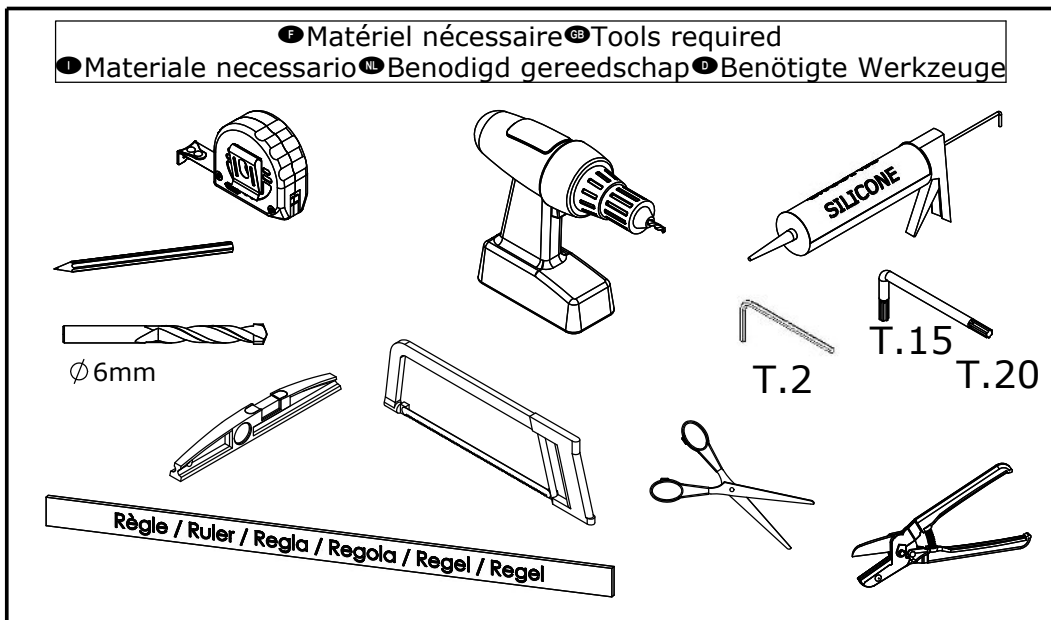

● REVERSIBILITE ● REVERSIBILITY

● REVERSIBILITA ● OMKEERBAARHEID ● WAHLWEISE MONTAGE

● MONTAGE A GAUCHE

● LEFT HAND

● MONTAGGIO A SINISTRA

● MONTAGE LINKS

● MONTAGE LINKS

● MONTAGE A DROITE

● RIGHT HAND

● MONTAGGIO A DESTRA

● MONTAGE RECHTS

● MONTAGE RECHTS

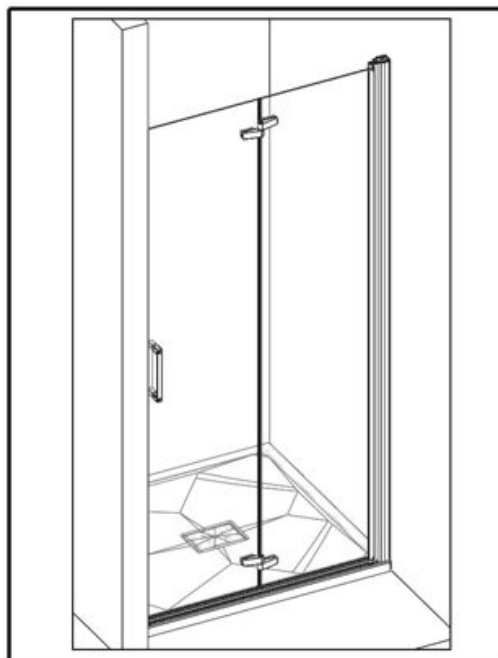
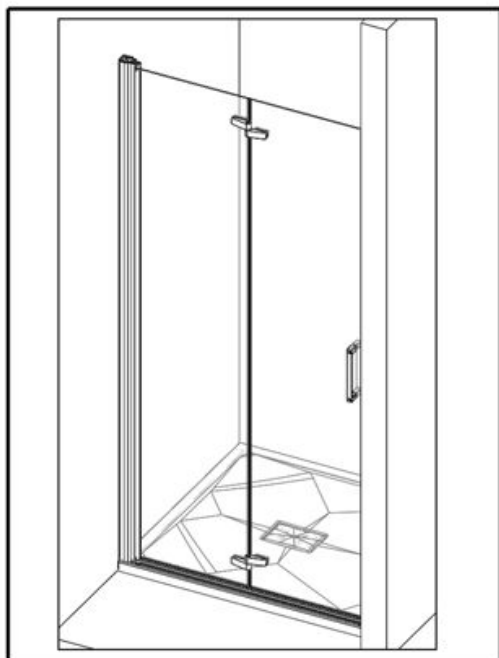

● Vous avez la possibilité de réaliser un montage à droite ou un montage à gauche. Notre notice d'installation décrit un montage à gauche. Si vous voulez réaliser un montage à droite, il vous suffit d'inverser le montage.

● This cubicle can be installed either left or right hand. These installation instructions show a left hand installation.

● Avete la possibilità di effettuare il montaggio a destra o a sinistra. Il nostro manuale descrive il montaggio a sinistra. Se volete realizzare il montaggio a destra è sufficiente invertire varie fasi di montaggio.

● U kunt de douchecabine rechts of links monteren. Onze handleiding beschrijft de links montage van de cabine. Keer de montage om als u de cabine rechts wilt monteren.

● Sie haben die Möglichkeit, eine Montage auf der linken Seite oder eine Montage auf der rechten Seite durchzuführen. Unsere Montageanleitung beschreibt eine Montage auf der linken Seite. Wenn Sie die Montage lieber auf der rechten Seite durchführen wollen, müssen Sie nur den Montageprozess umkehren.

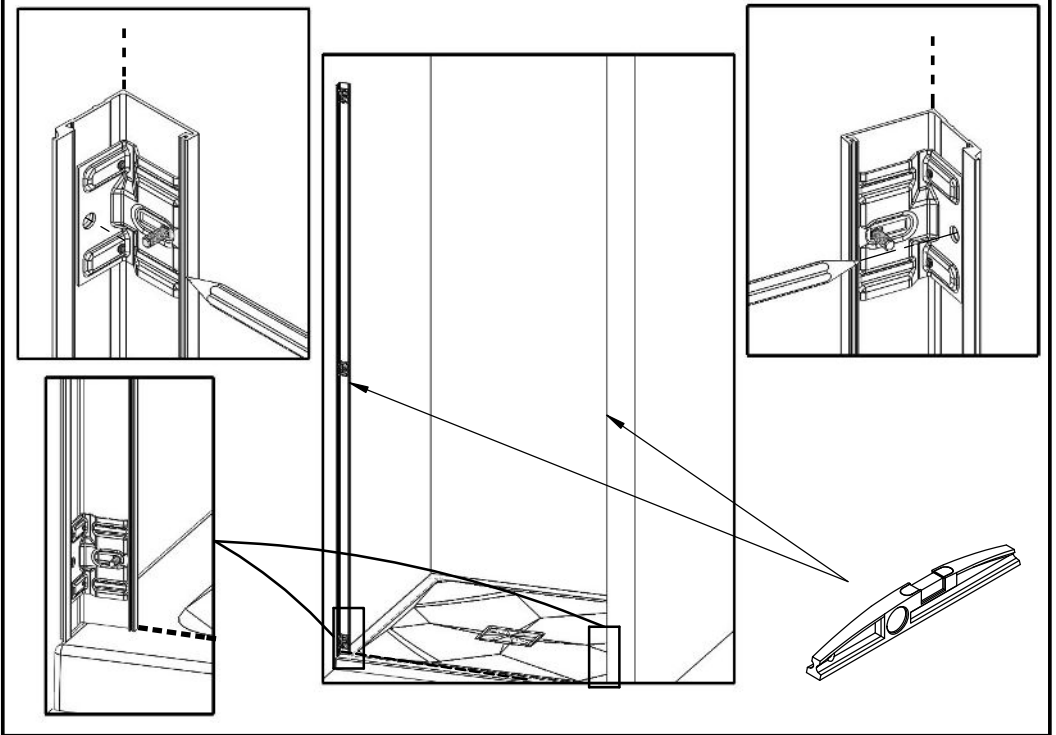
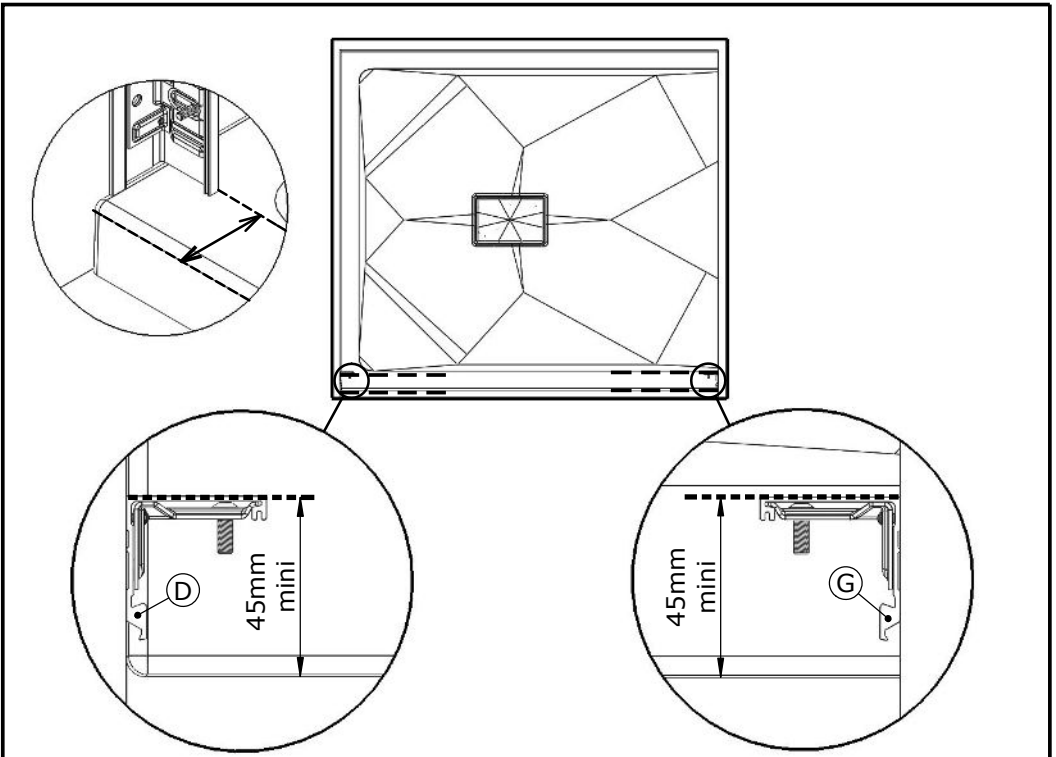

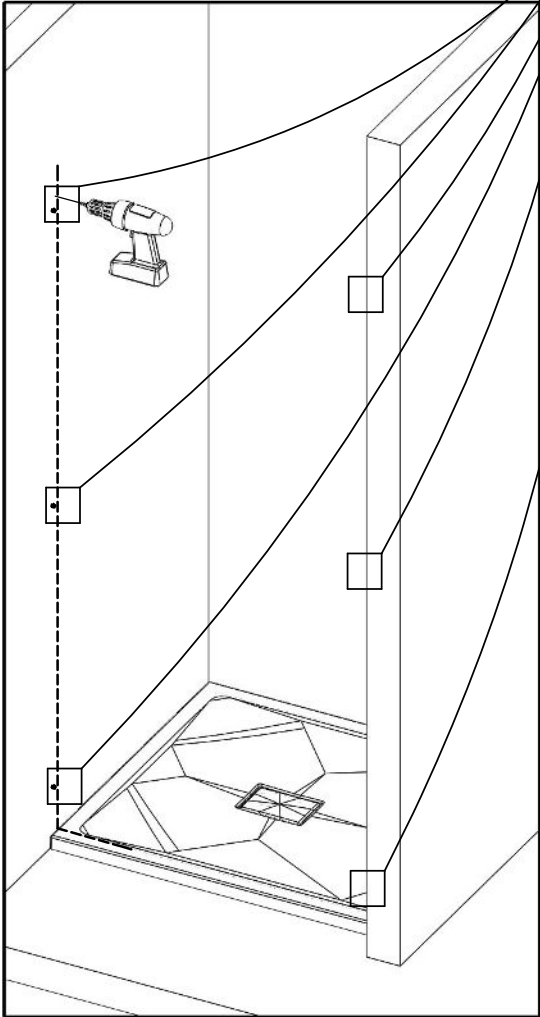
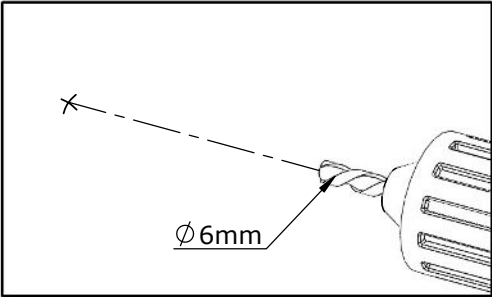

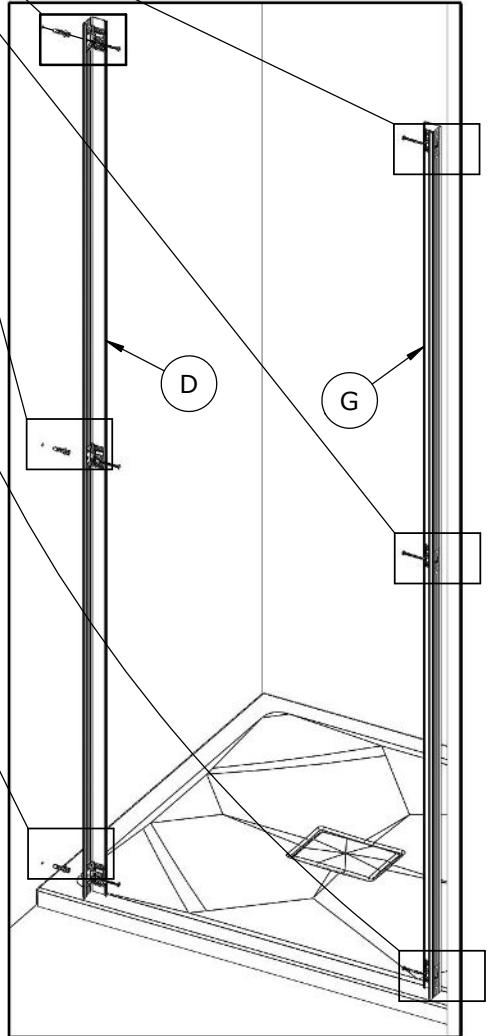
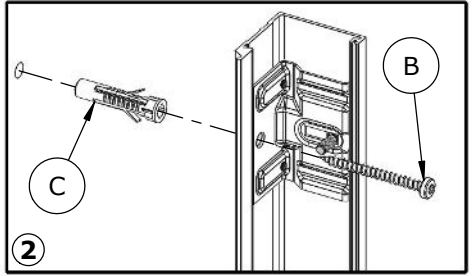
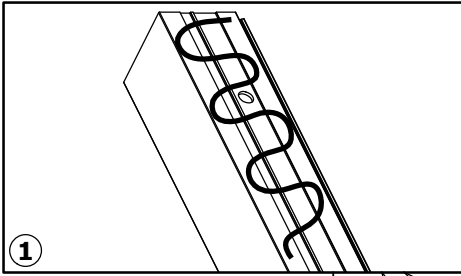

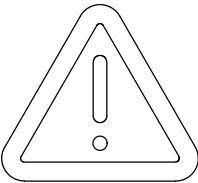
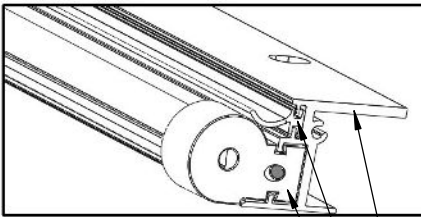
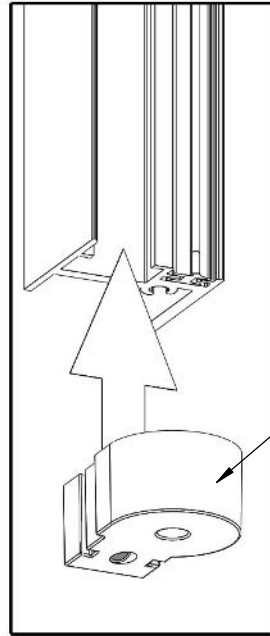
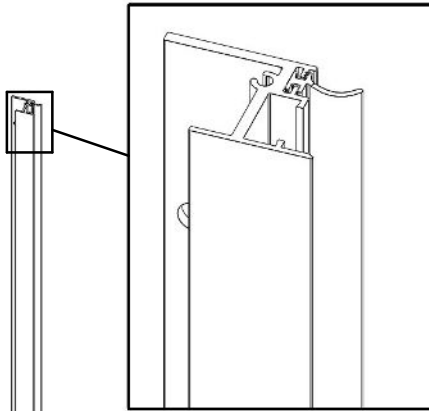

- Affleurant
- Align
- A filo
- Zijkanten niet laten uitsteken
- Bündig auszurichtende oberseiten

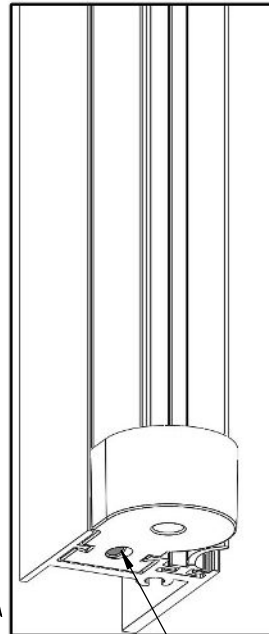

- Serrer
- Tighen
- Serrare
- Vastdraaien
- Festziehen

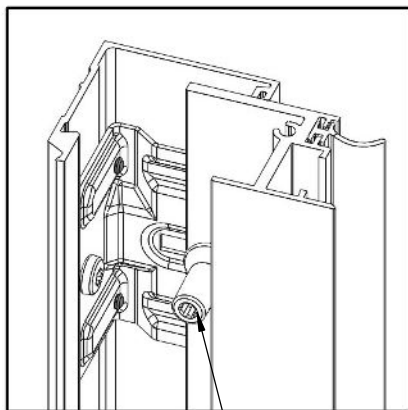
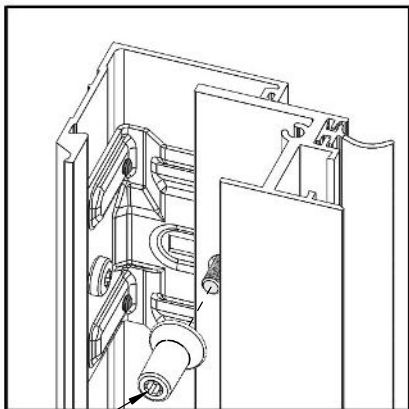

L

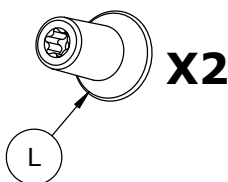
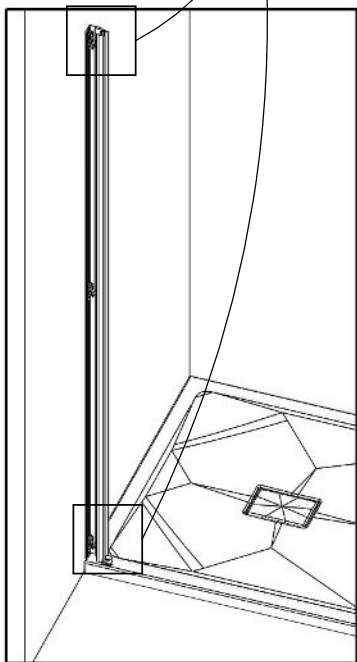

- serrer
- Ⓒ Tighten
- Serrare
- Ⓓ Vastdraaien
- Festziehen

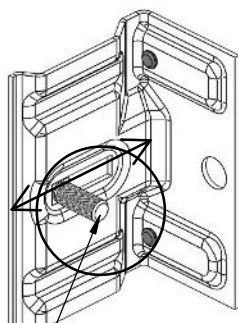
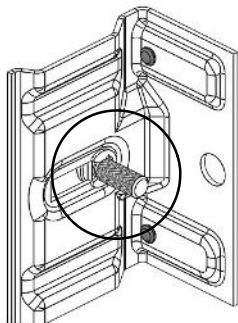
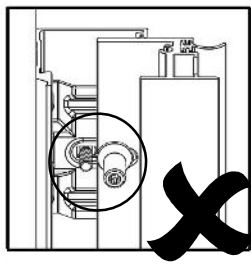
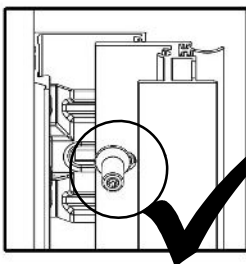

- Si nécessaire, desserrer, régler puis resserrer
- Ⓒ If necessary, loosen, adjust and retighten
- Se necessario, allentare, regolare e stringere
- Ⓓ Draai los, indien nodig, stel af en draai vervolgens weer vast
- Falls erforderlich, lösen, einstellen und wieder festziehen

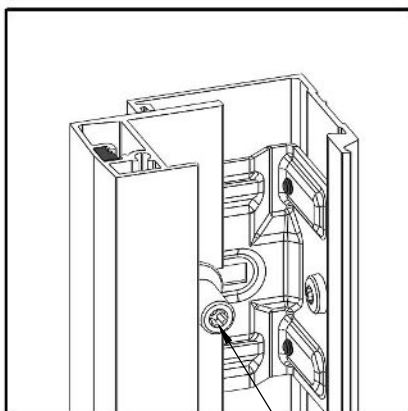
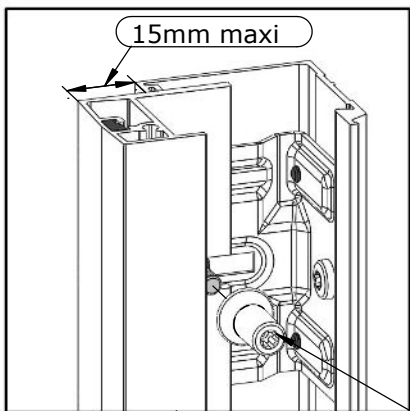

L

- Serrer
- Ⓔ Tighten
- Serrare
- Ⓗ Vastdraaien
- Festziehen

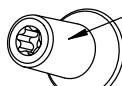

X2

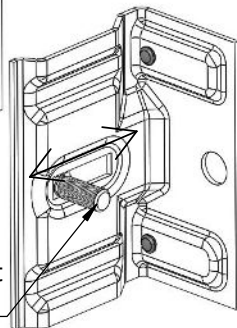
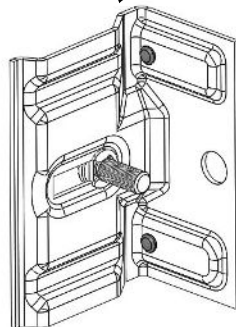
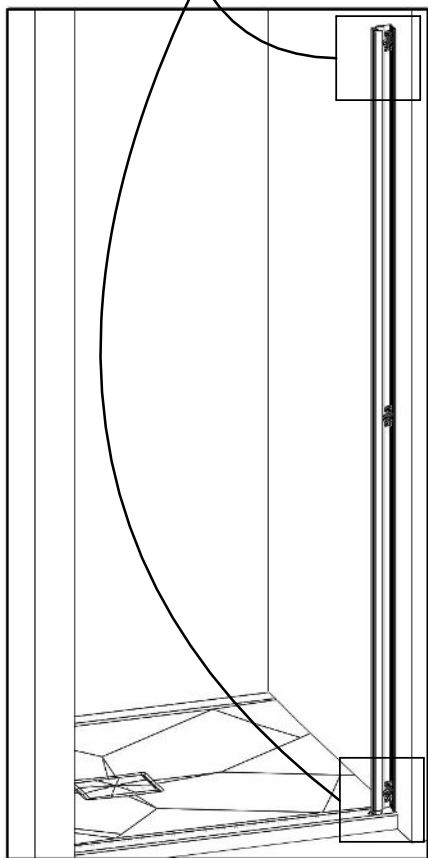
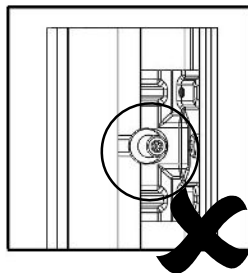
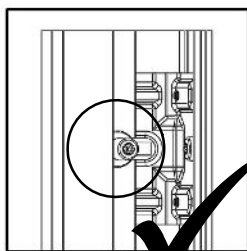

- Si nécessaire, desserrer, régler puis resserrer
- Ⓔ If necessary, loosen, adjust and retighten
- Se necessario, allentare, regolare e stringere
- Ⓗ Draai los, indien nodig, stel af en draai vervolgens weer vast
- Falls erforderlich, lösen, einstellen und wieder festziehen

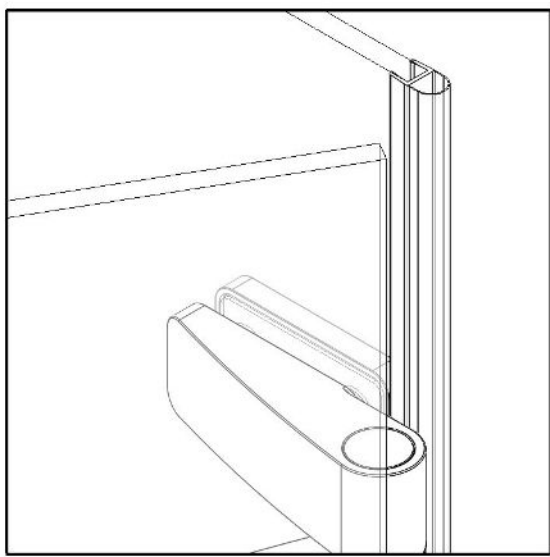
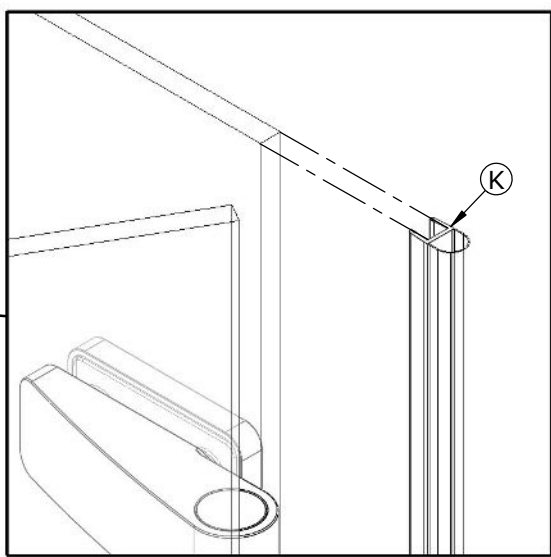
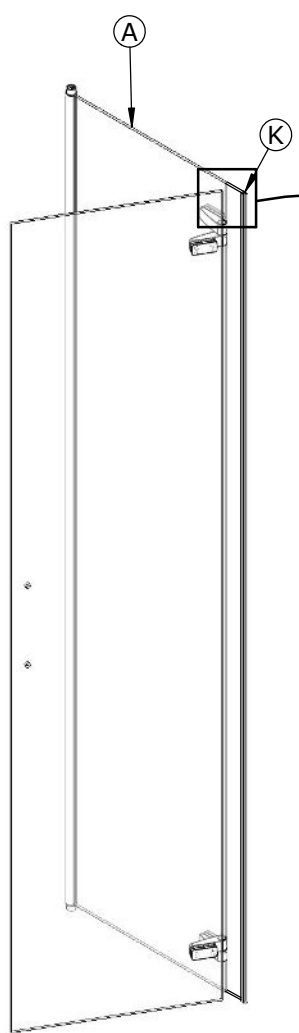

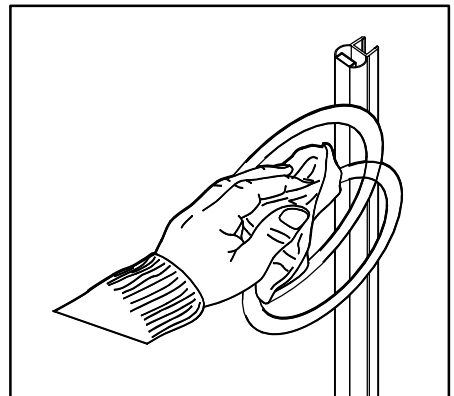
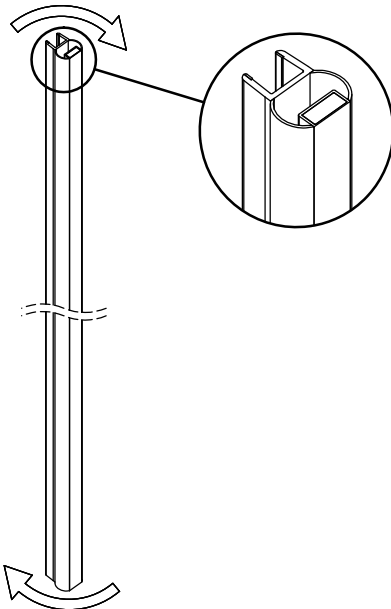
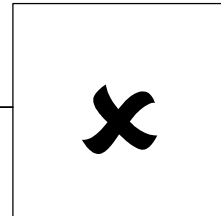
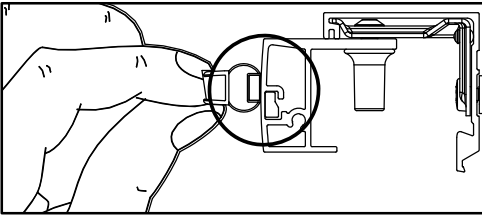
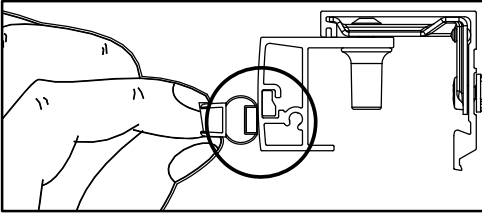
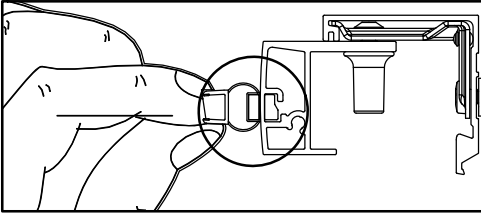

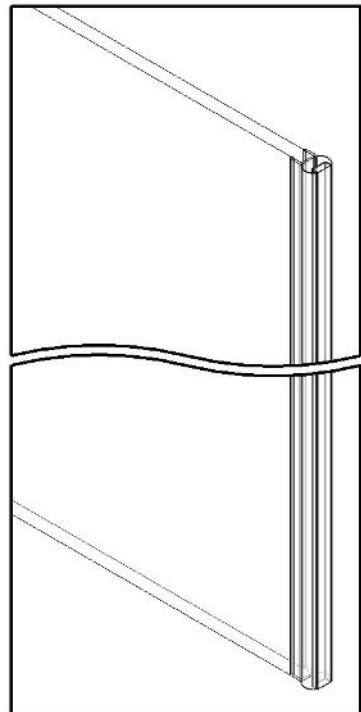
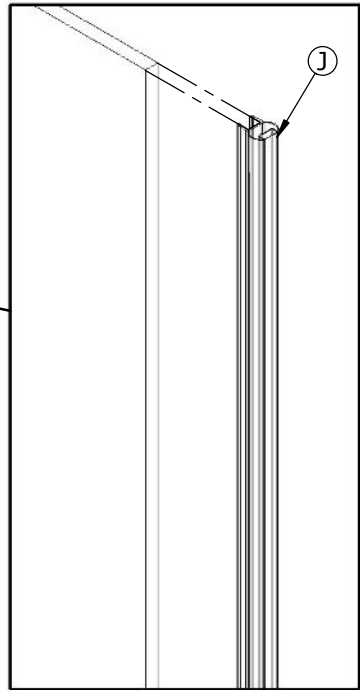
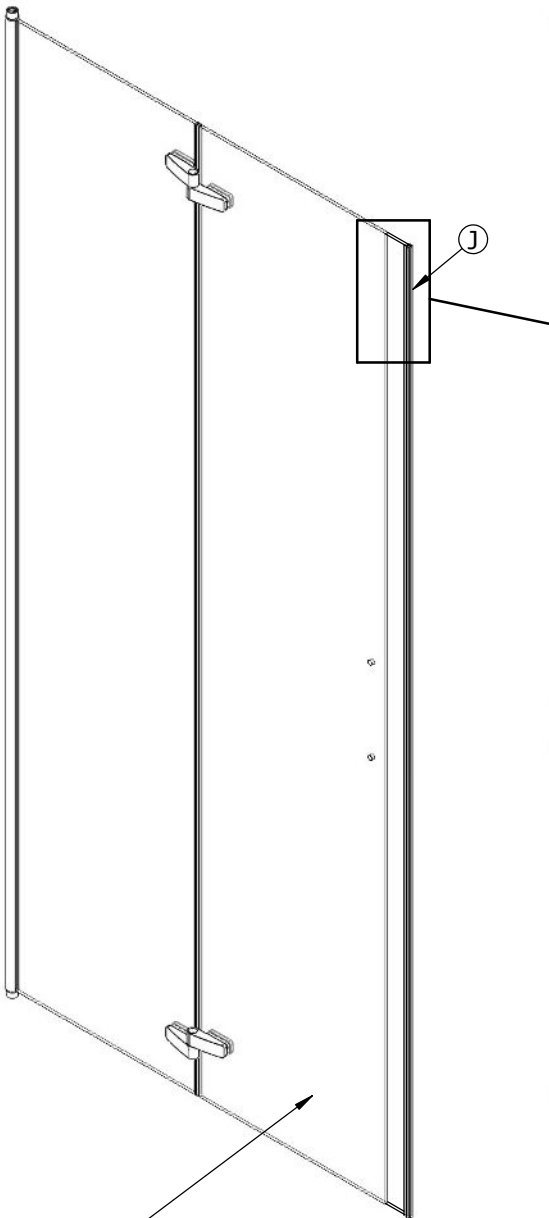

- F Extérieur douche
- GB outside shower
- I Esterno doccia
- NL Buitenkant van de douche
- D Außenansicht der Kabine

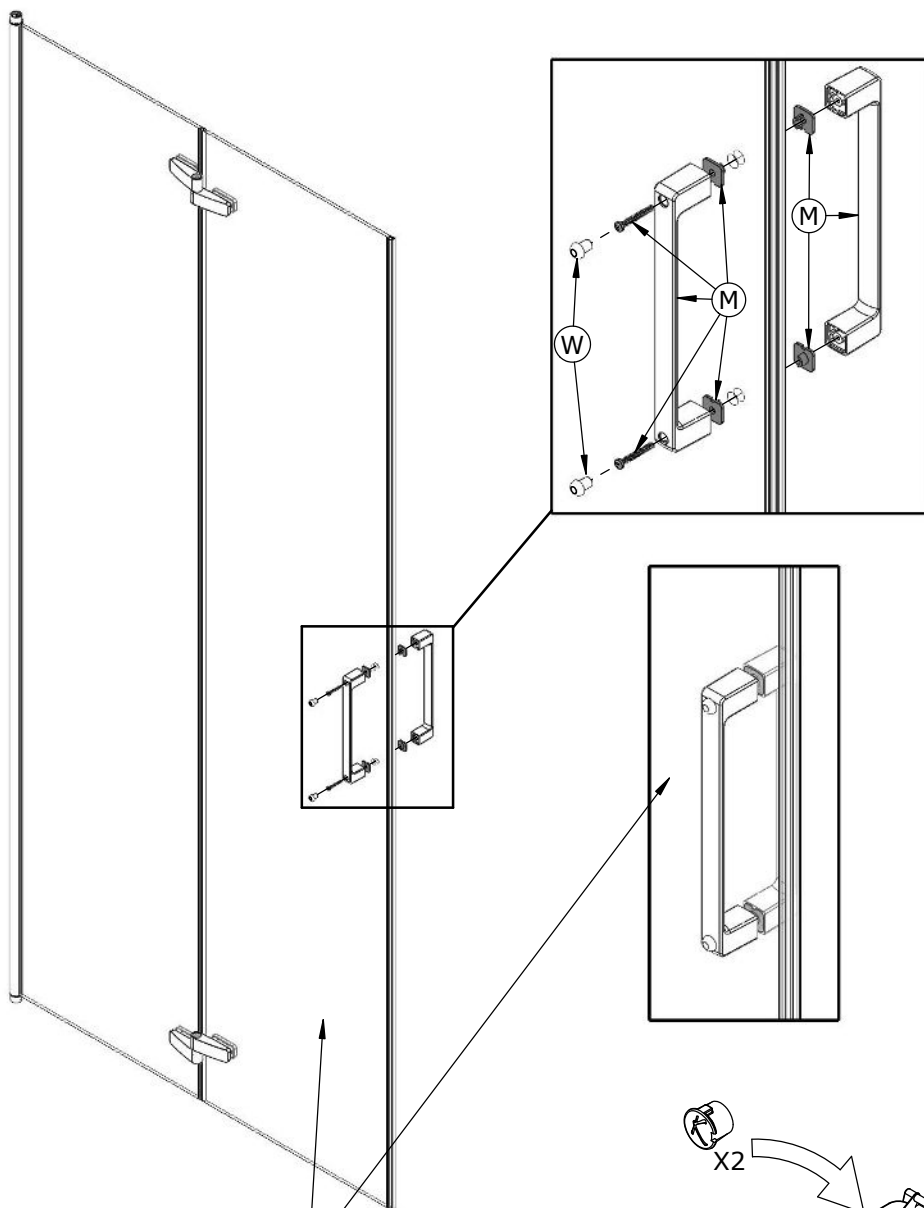

- F Extérieur douche
- GB outside shower
- I Esterno doccia
- NL Buitenkant van de douche
- D Außenansicht der Kabine

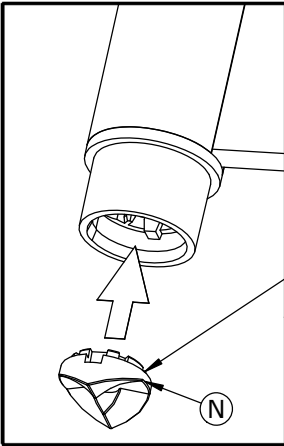
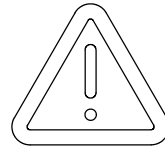

- Mettre (N) en partie basse
- Put (N) in the lower part
- Mettere (N) nella parte inferiore
- Plaats (N) in het onderste deel
- Setzen Sie (N) in den unteren Teil.

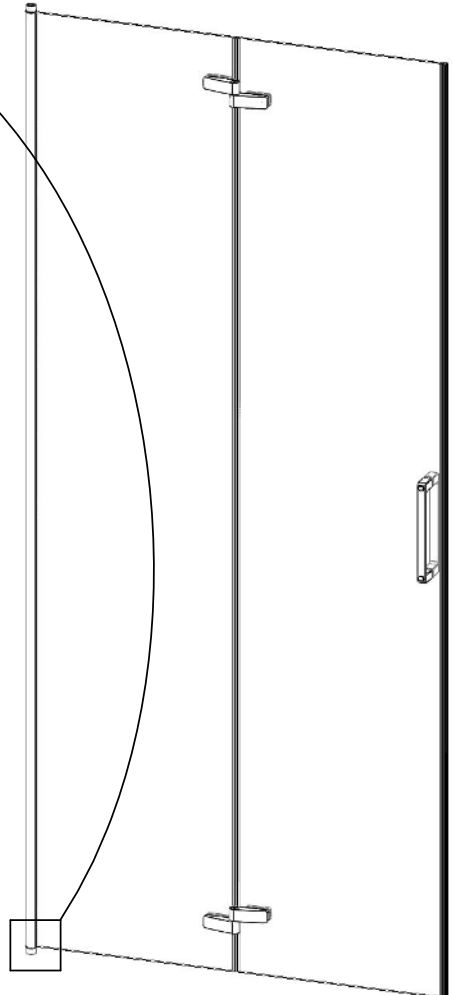
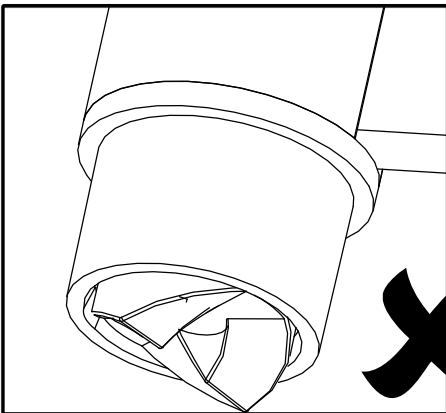
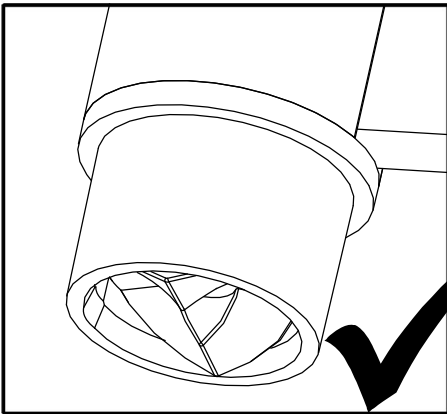

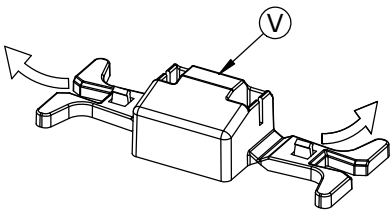

X4

- Extérieur douche
- outside shower
- Esterno doccia
- Buitenkant van de douche
- Außenansicht der Kabine

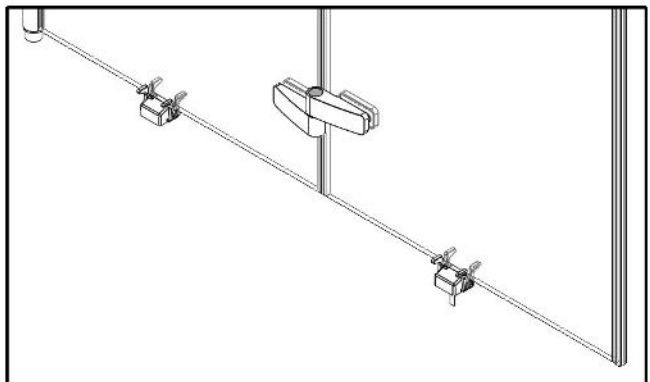
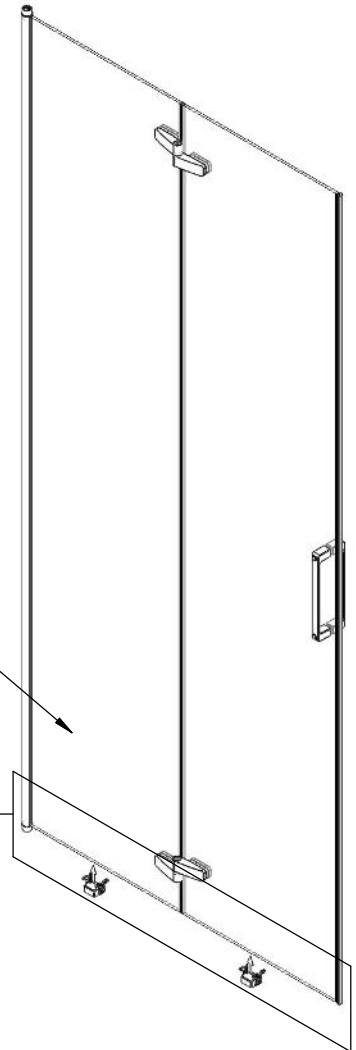
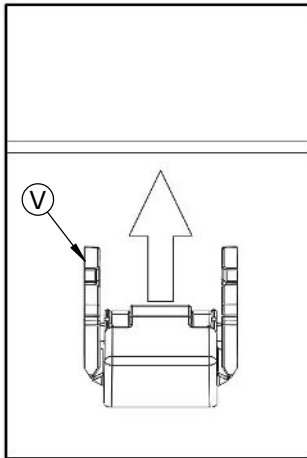
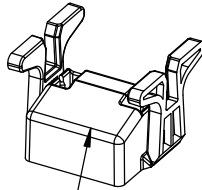

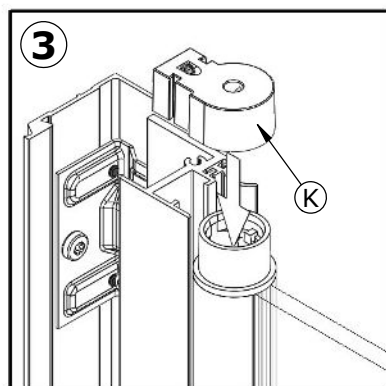
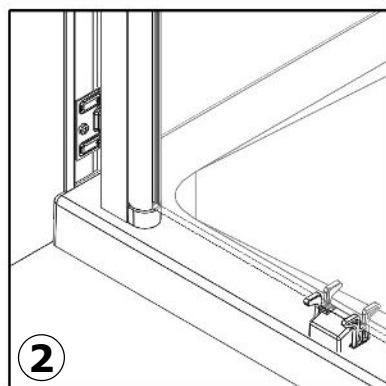
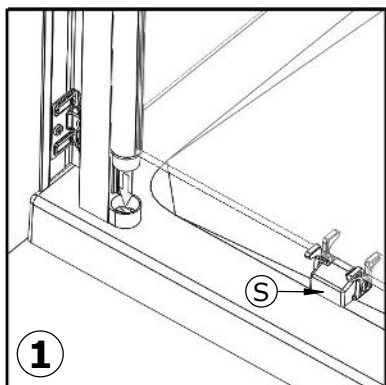
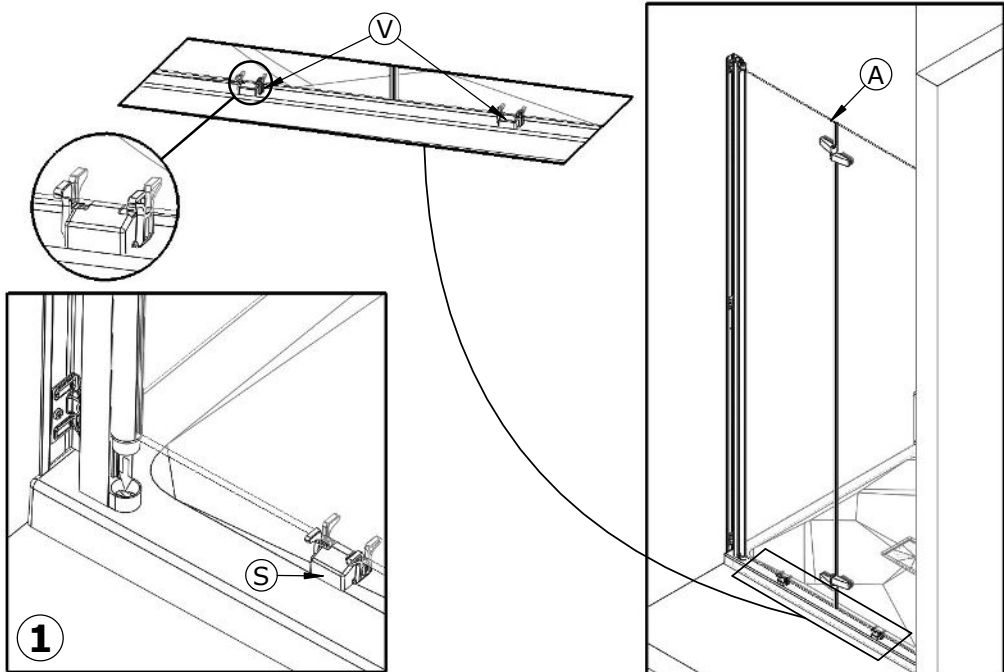

- Affleurant
- Align
- A filo
- Zijkanten niet laten uitsteken
- Bündig auszurichtende oberseiten

- Serrer
- Tighten
- Serrare
- Vastdraaien
- Festziehen

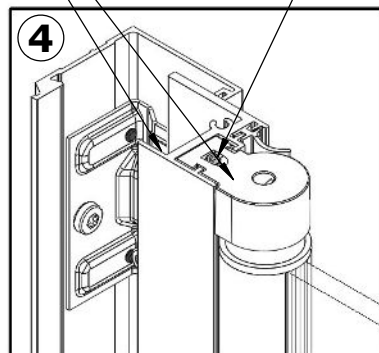

- Ⓕ Si nécessaire, desserrer, régler puis resserrer
- ⒼⒷ If necessary, loosen, adjust and retighten
- Ⓘ Se necessario, allentare, regolare e stringere
- Ⓝ Draai los, indien nodig, stel af en draai vervolgens weer vast
- Ⓓ Falls erforderlich, lösen, einstellen und wieder festziehen

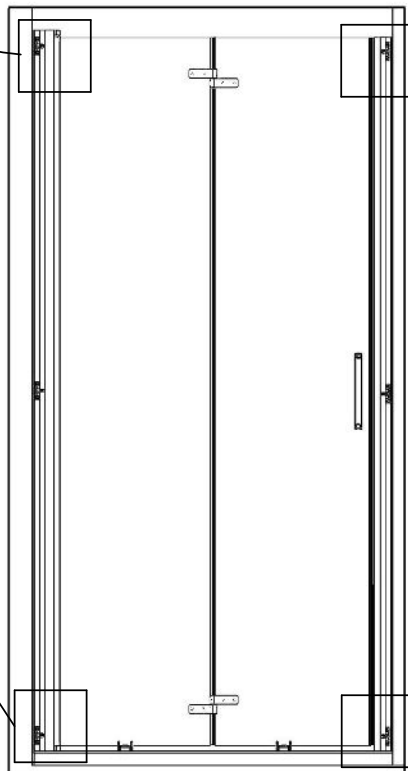
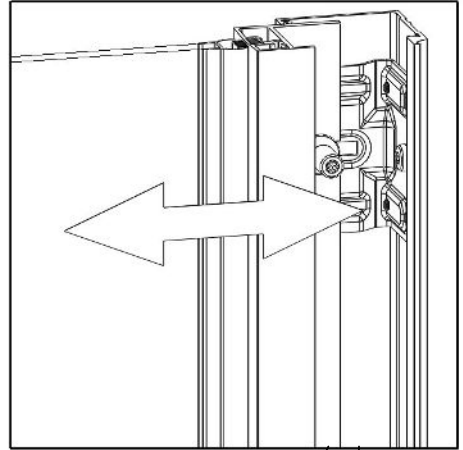
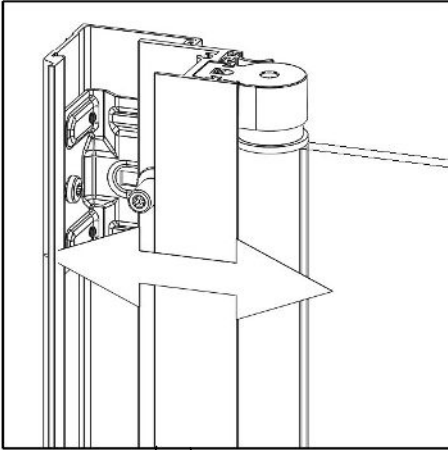
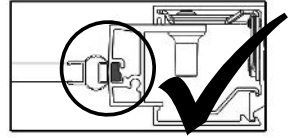

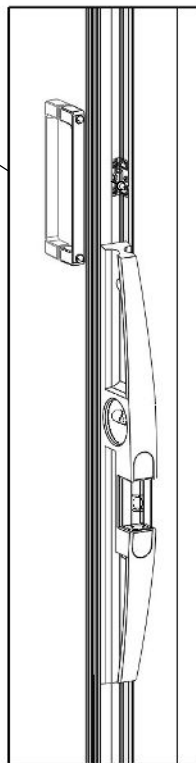
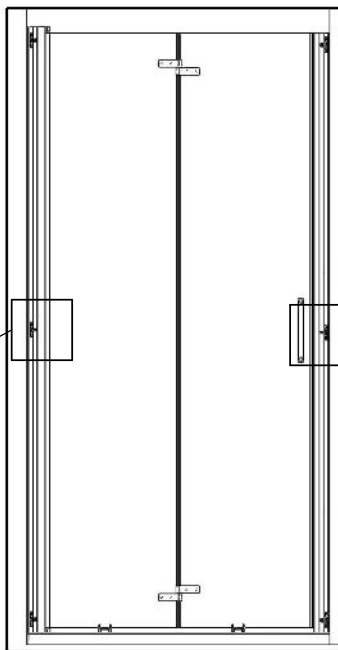
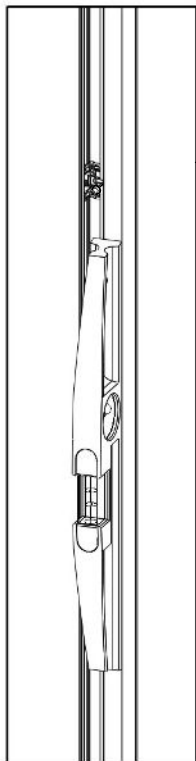
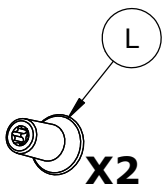

- F Adjuster puis serrer
- GB Fit then tighten
- I Regolare e poi serrare
- NL Stel af en draai vast
- D Anpassen dann anziehen

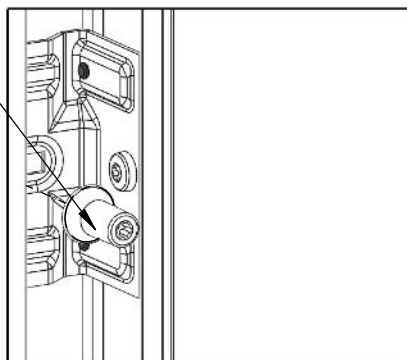
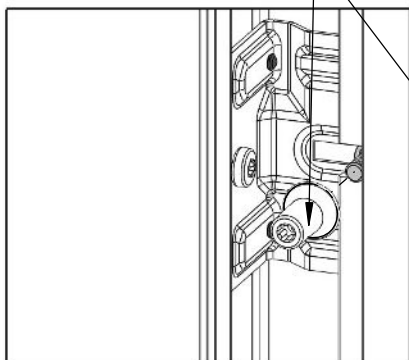

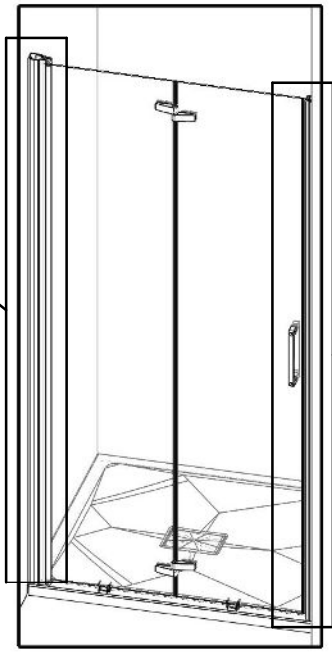
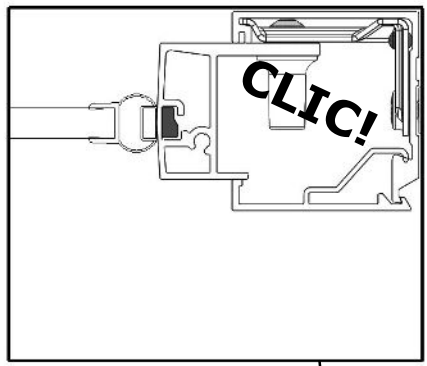
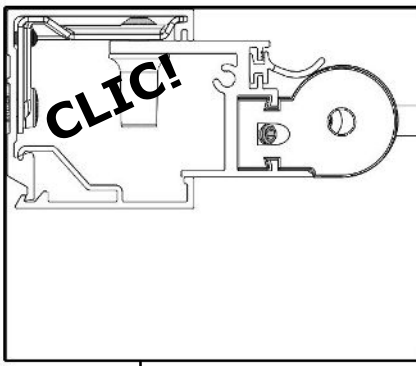
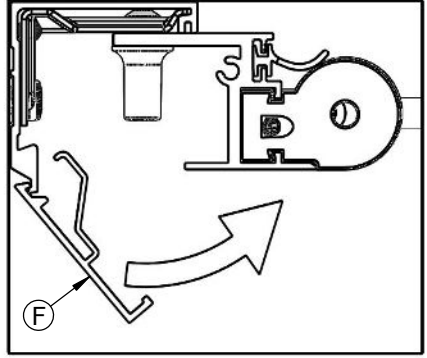
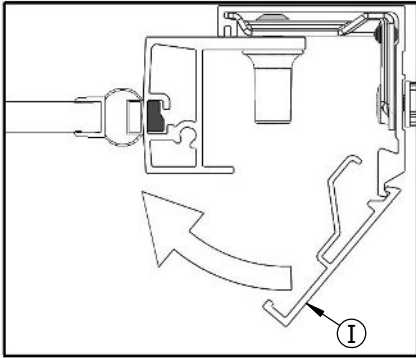

- Retirer (Q) ● Remove (Q) ● Togliere (Q)
- Verwijderen (Q) ● Entfernen (Q)

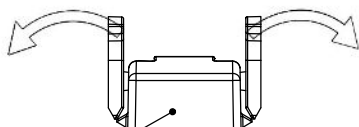

Q

X4

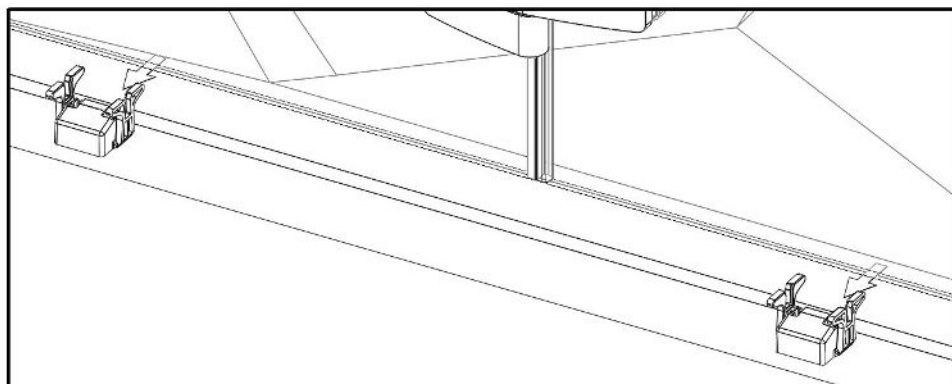
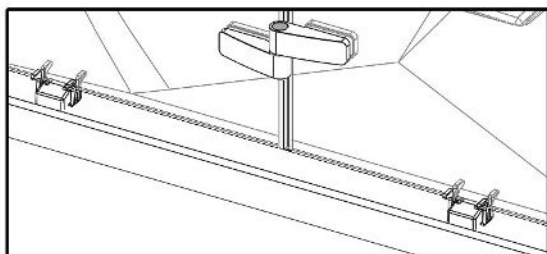
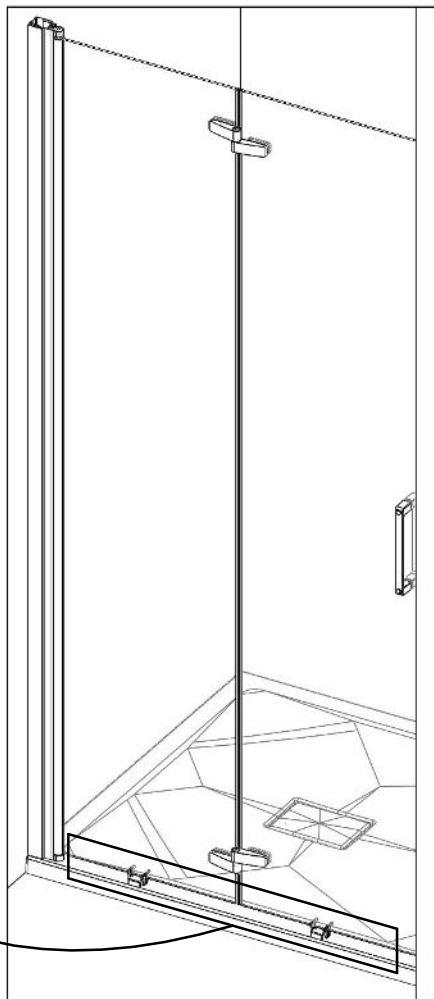

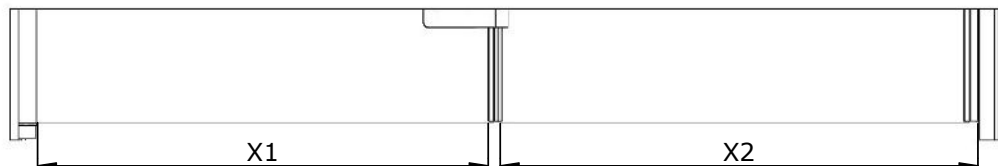

- Intérieur douche
- Inside shower
- Doccia interni
- Binnenkant van de douche
- Innenraum der Kabine

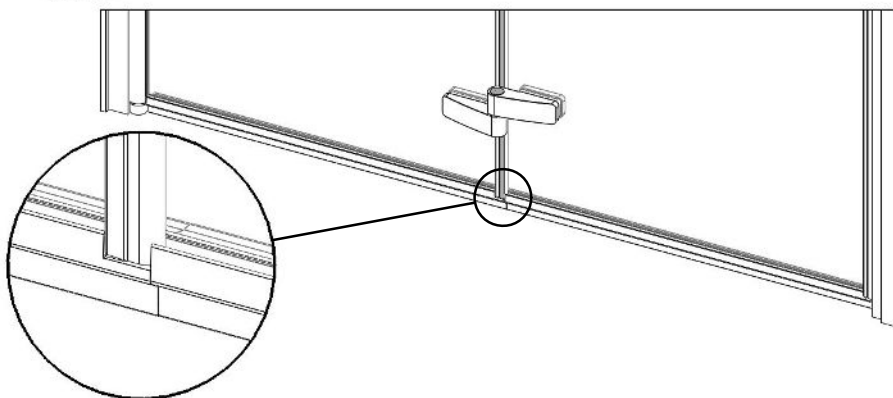
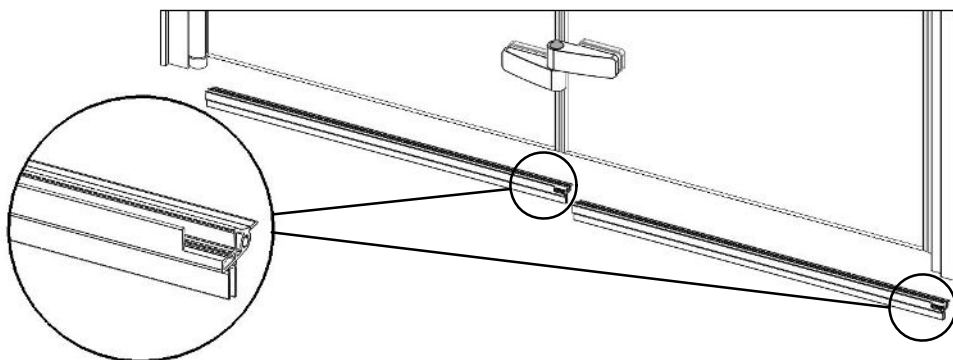
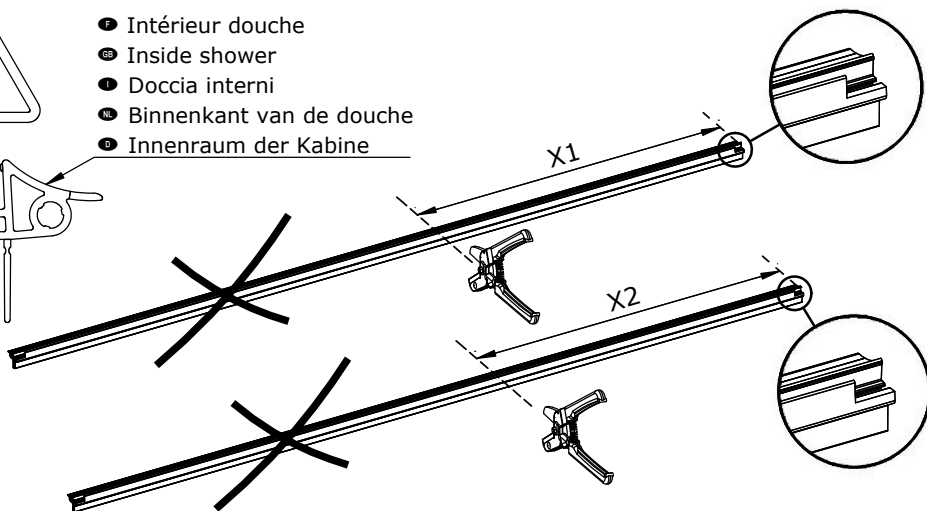
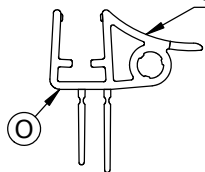

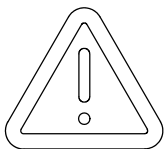

- SENS POUR MONTAGE A GAUCHE, INVERSER POUR MONTAGE A DROITE.
- SENSE FOR MOUNTING ON THE LEFT, REVERSE FOR RIGHT MOUNTING.
- DIREZIONE PER IL MONTAGGIO A SINISTRA, INVERSO PER IL MONTAGGIO A DESTRA.
- RICHTING VOOR LINKERMONTAGE, ACHTERUIT VOOR RECHTERMONTAGE.
- RICHTUNG FÜR DIE LINKE MONTAGE, UMGEKEHRT FÜR DIE RECHTE MONTAGE.

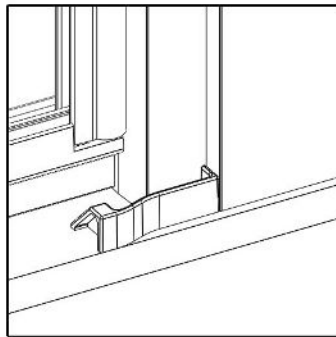
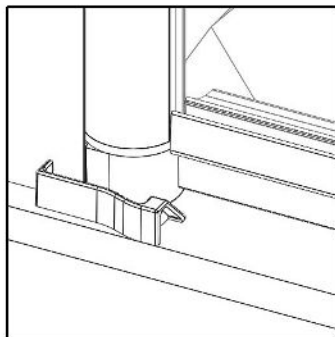
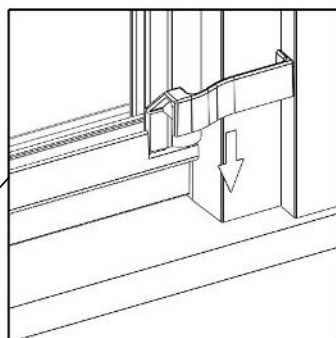
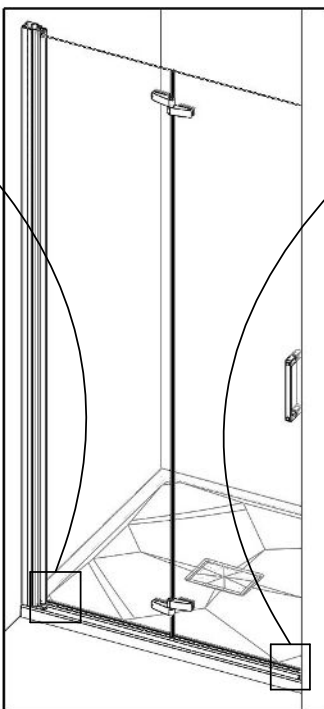
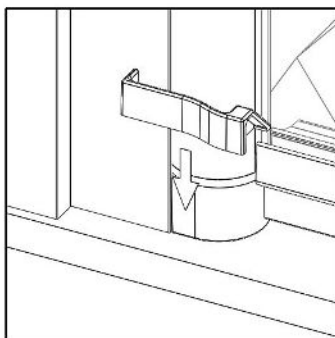
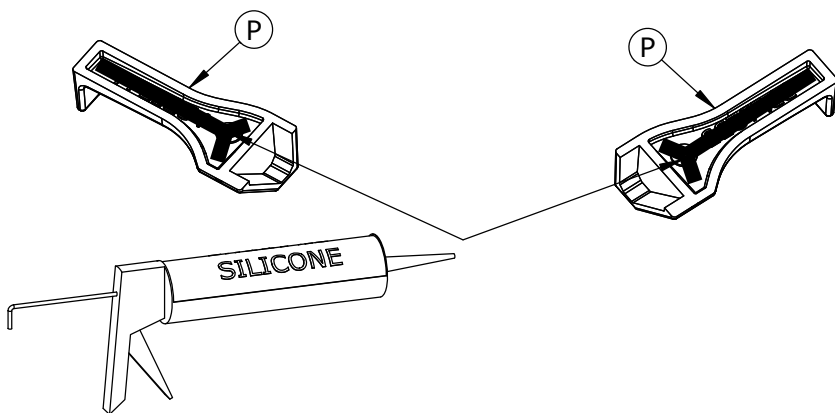

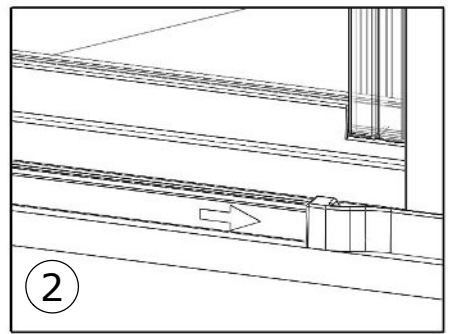
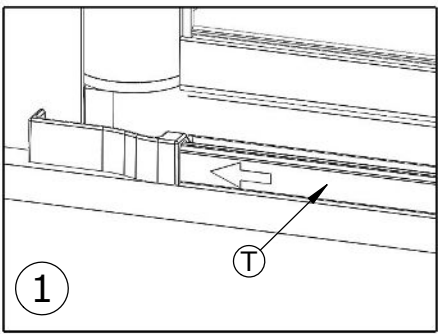
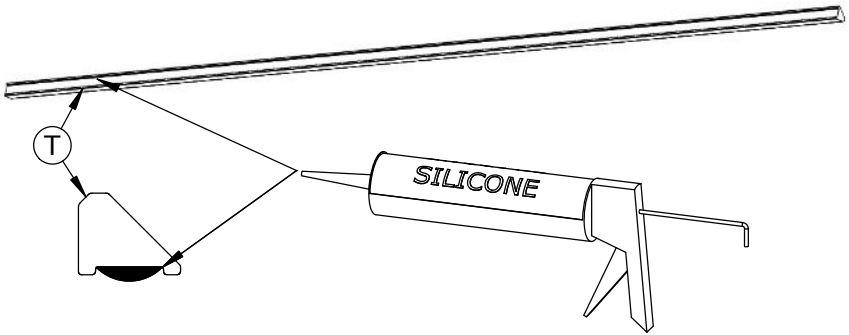
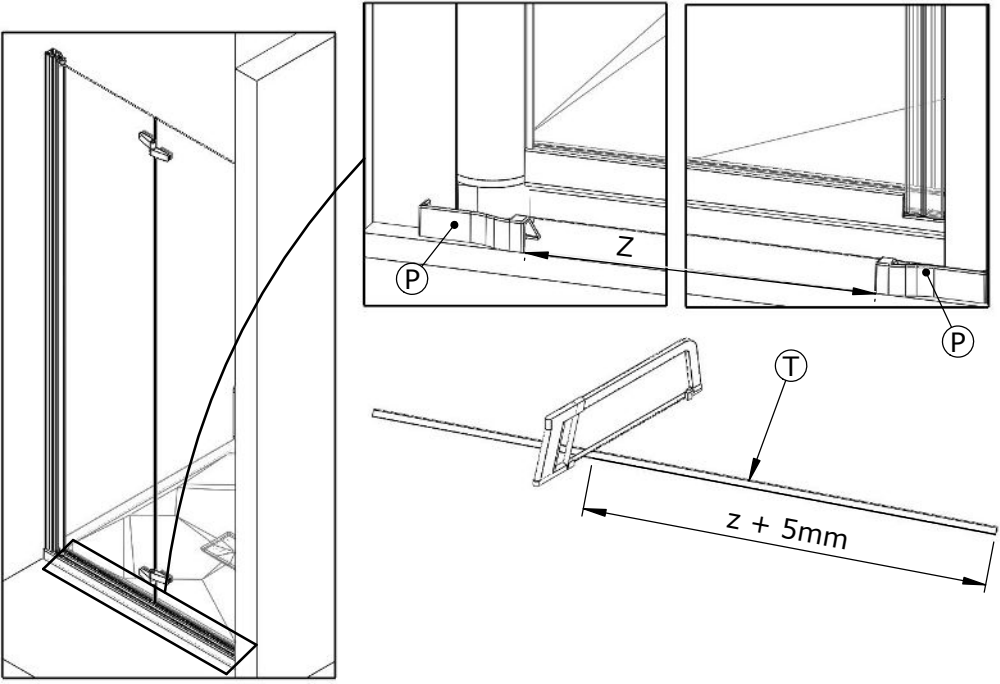

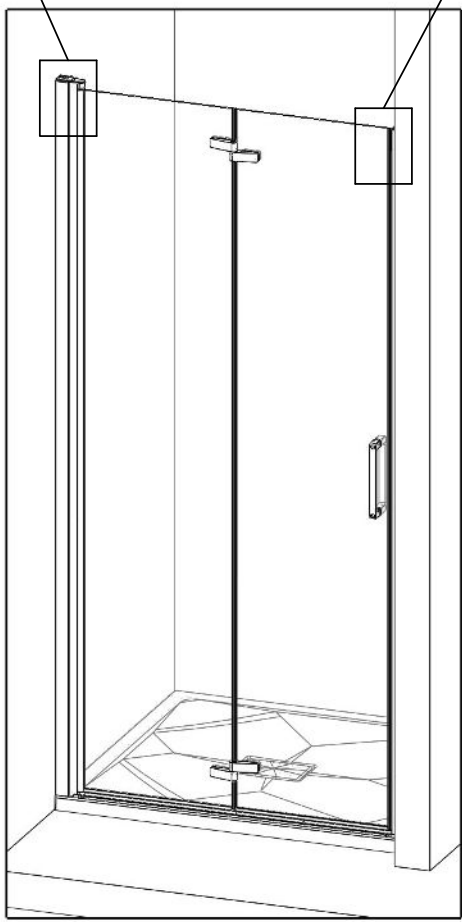
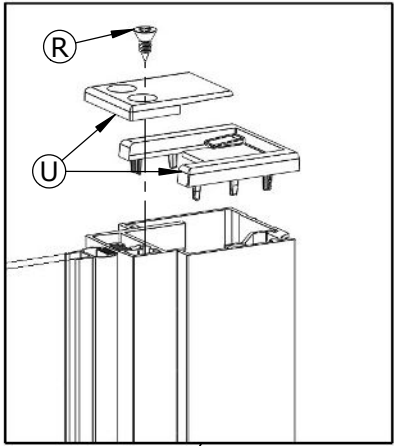
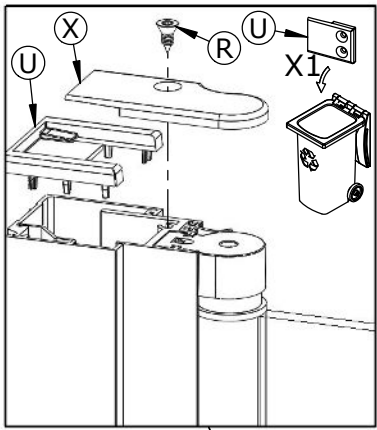

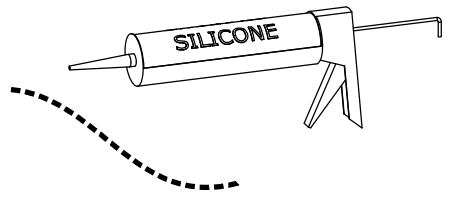
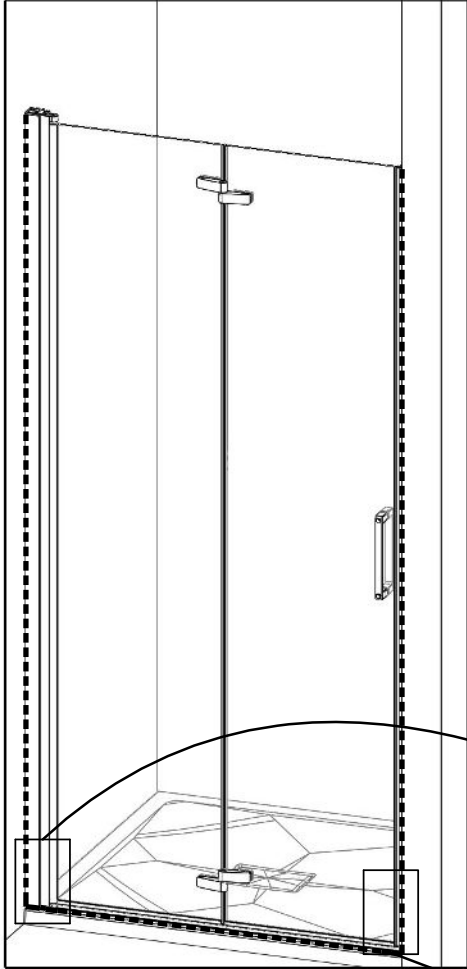

24h

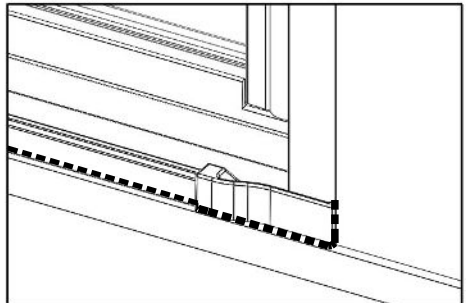
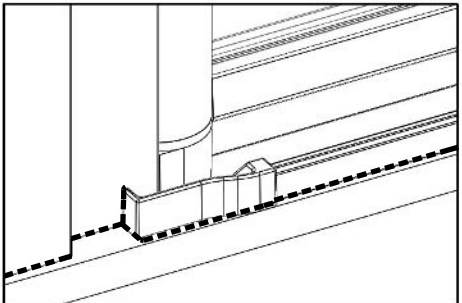
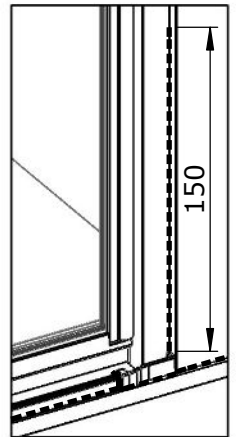
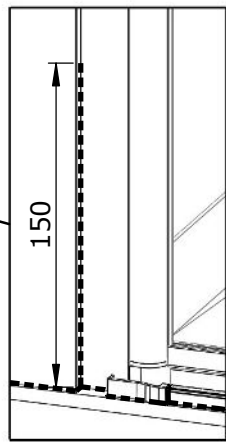



SAV
SERVICE HELPLINES
ASSISTENZA POST-VENTITA
SERVICIO POSTVENTA

FRANCE

02 40 21 29 45

UK

020 8842 0033

IRELAND

04697 33102

DEUTSCHLAND

+49 (0) 6074 / 30928 0

ITALIA

(0382) 6181

OSTEREICH

+43 1 710 60 70

SCHWEIZ

(01) 748 17 44

ESPANA

93 544 60 76

NEDERLAND

+31 475 487 100

BELGIE

+31 475 487 100

BELGIQUE

+31 475 487 100

РОССИЯ

963 19 40, 773 67 22



AQUAPRODUCTION, Site industriel,
 F - 44680 Chaumes-en-Retz

18

EN 14428

Paroi de douche, fabriquée en verre de silicate
 sodo-calcique de sécurité trempé thermiquement

Aptitude au nettoyage : réussite

Résistance à l'impact/propriétés de fragmentation : réussite

Durabilité : réussite