

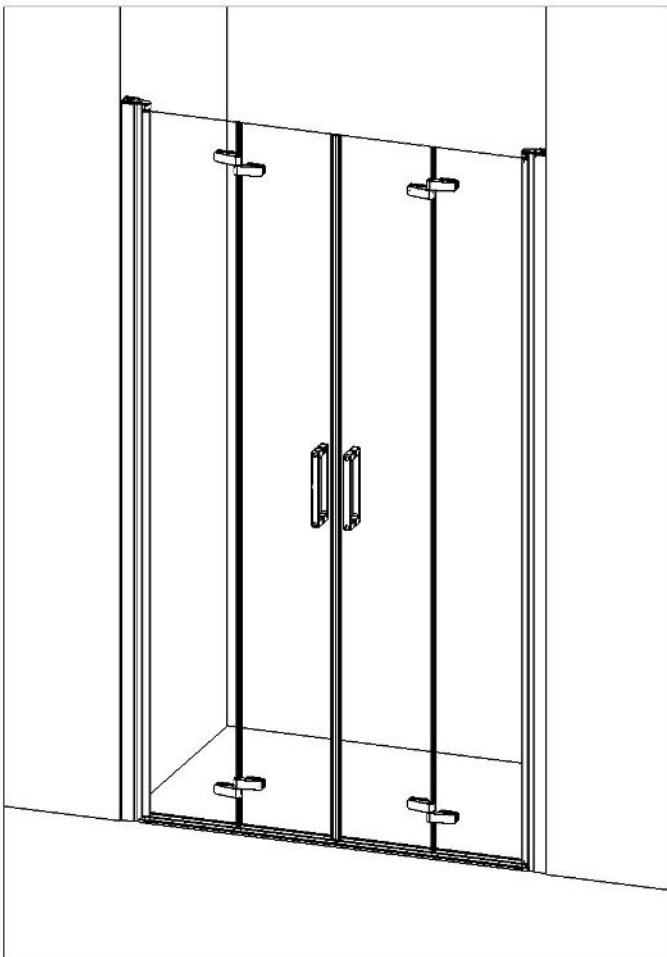

- F Notice de montage ● GB Installation instructions
- E Manual de instalación ● I Istruzioni di montaggio
- NL Montage-instructies ● D Montageanleitung

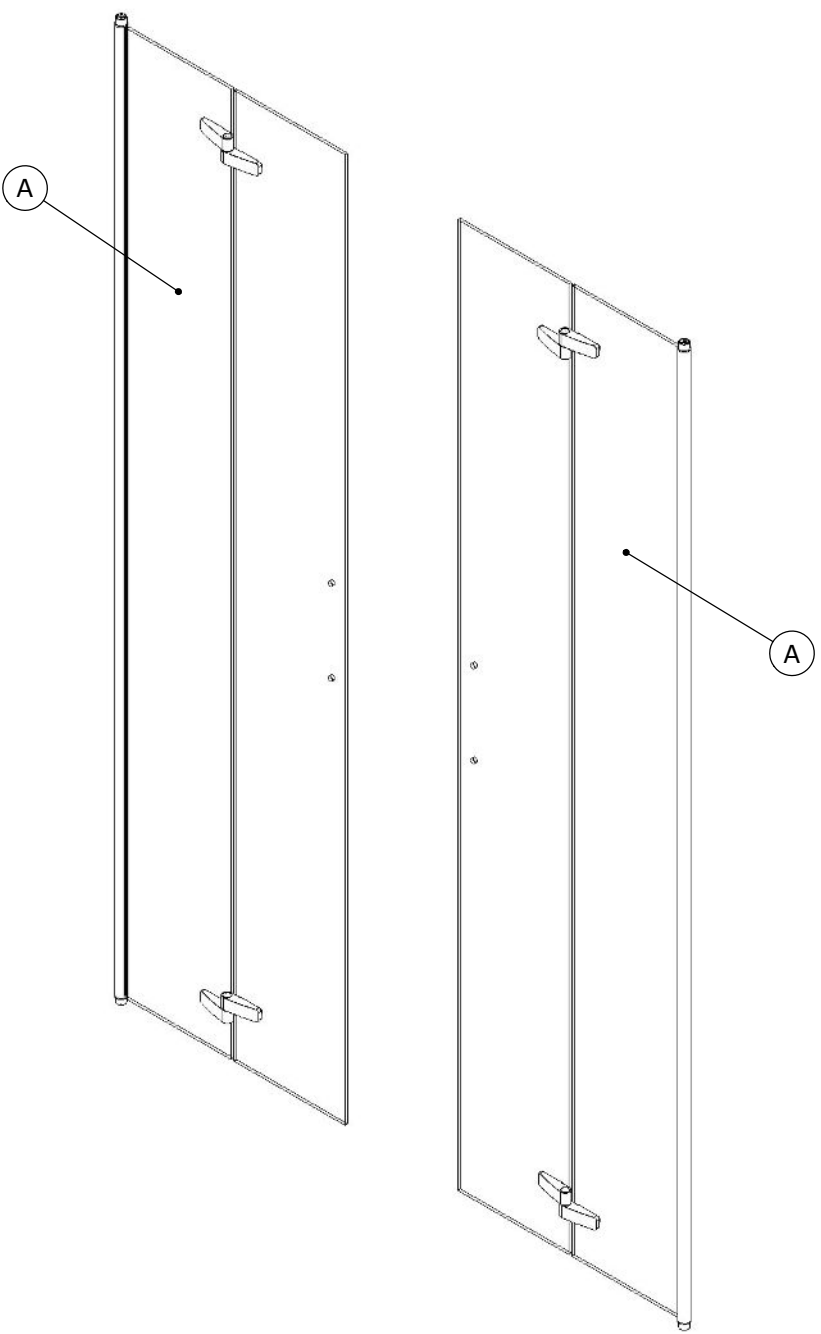

- Attention aux étapes :
- GB Check installation steps :
- E Atención a los pasos :
- I Attenzione ai passi :
- NL Aandacht voor de stappen :
- D Achtung vor den Schritten :

P. 5 - 14 - 24

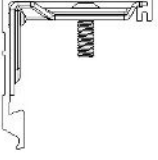
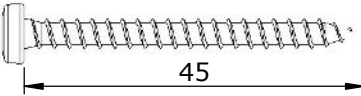
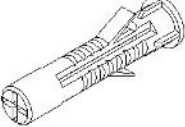
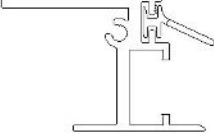
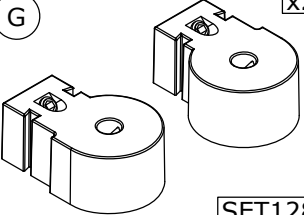
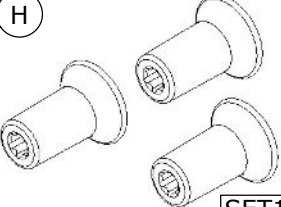
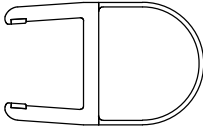
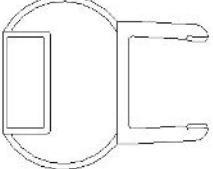
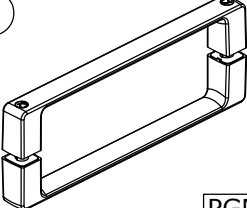
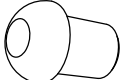
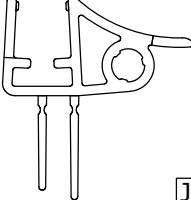
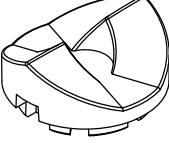
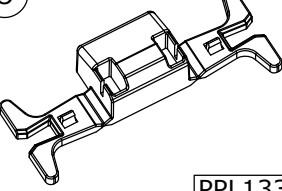

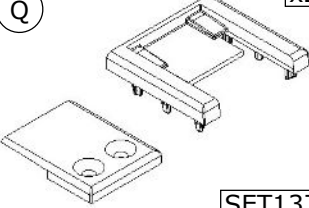
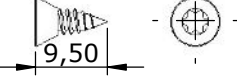
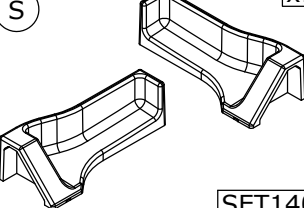
<p><b>C</b> <span style="float: right;">x2</span></p>  <p style="text-align: right;"><b>6268</b></p>	<p><b>D</b> <span style="float: right;">Ø4</span> <span style="float: right;">x6</span></p>  <p style="text-align: right;"><b>VIS231</b></p>	
<p><b>E</b> <span style="float: right;">x6</span></p>  <p style="text-align: right;"><b>CHE02</b></p>	<p><b>F</b> <span style="float: right;">x2</span></p>  <p style="text-align: right;"><b>6272</b></p>	<p><b>G</b> <span style="float: right;">x2</span></p>  <p style="text-align: right;"><b>SET128</b></p>
<p><b>H</b> <span style="float: right;">x2</span></p>  <p style="text-align: right;"><b>SET134</b></p>	<p><b>I</b> <span style="float: right;">x2</span></p>  <p>Lg=1962mm <span style="float: right;"><b>J808</b></span></p>	<p><b>J</b> <span style="float: right;">x2</span></p>  <p>Lg=1962mm <span style="float: right;"><b>AI178</b></span></p>
<p><b>K</b> <span style="float: right;">x2</span></p>  <p style="text-align: right;"><b>PGN49</b></p>	<p><b>L</b> <span style="float: right;">x4</span></p>  <p style="text-align: right;"><b>BUT44</b></p>	<p><b>M</b> <span style="float: right;">x2</span></p>  <p style="text-align: right;"><b>J806</b></p>
<p><b>N</b> <span style="float: right;">x2</span></p>  <p style="text-align: right;"><b>PPL1248</b></p>	<p><b>O</b> <span style="float: right;">x4</span></p>  <p style="text-align: right;"><b>PPL1339</b></p>	<p><b>P</b> <span style="float: right;">x2</span></p>  <p style="text-align: right;"><b>6270</b></p>
<p><b>Q</b> <span style="float: right;">x2</span></p>  <p style="text-align: right;"><b>SET137</b></p>	<p><b>R</b> <span style="float: right;">Ø3.5</span> <span style="float: right;">x2</span></p>  <p style="text-align: right;"><b>VIS261</b></p>	<p><b>S</b> <span style="float: right;">x1</span></p>  <p style="text-align: right;"><b>SET140</b></p>

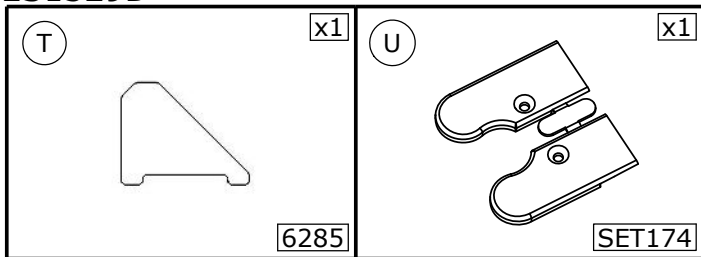

- Les quantités données sont les quantités utiles au montage. les sachets fournis contiennent des pièces supplémentaires.
- The quantities given are what are required for the installation. There may be some surplus in the package provide.
- Las cantidades indicadas son las cantidades necesarias para el montaje. Las bolsitas incluidas contienen piezas suplementarias.
- Le quantità fornite sono le quantità necessarie al montaggio. I sacchetti forniti contengono pezzi supplementari.
- De aangegeven aantallen zijn vereist voor de montage. De verpakking bevat extra onderdelen.

• Die Mengen sind die benötigten Mengen für die Montage. Die Verpackung enthält möglicherweise weitere Teile.

• Attrezzatura necessaria • Benodigde gereedschap • Equipamento necessário • Werkzeuge erforderlich

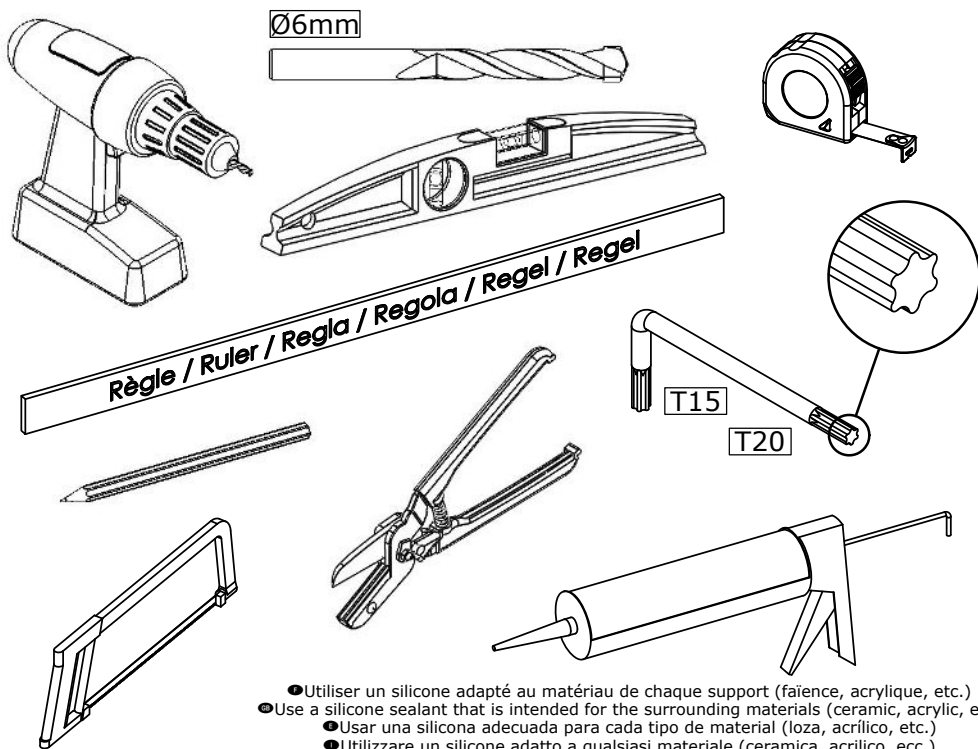

- Utiliser un silicone adapté au matériau de chaque support (faïence, acrylique, etc.)
- Use a silicone sealant that is intended for the surrounding materials (ceramic, acrylic, etc.)
- Usar una silicona adecuada para cada tipo de material (loza, acrílico, etc.)
- Utilizzare un silicone adatto a qualsiasi materiale (ceramica, acrilico, ecc.)
- Gebruik siliconenkit die geschikt is voor iedere ondergrond (tegelwerk, acryl, etc.)
- Für das jeweilige Trägermaterial (Stein, Acryl usw.) geeignetes Silikon verwenden.



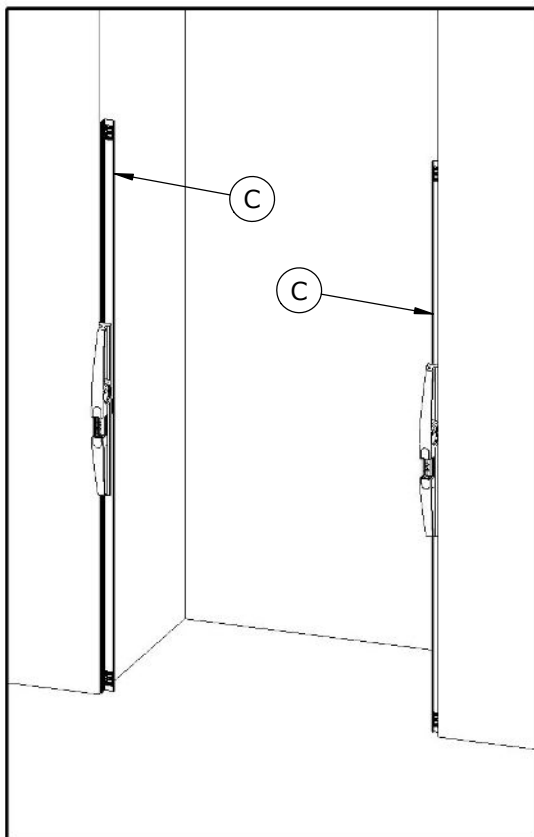

- Si receveur ● If shower tray
- Si plato ● Se piatto
- Als douchebak
- Wenn Duschwanne

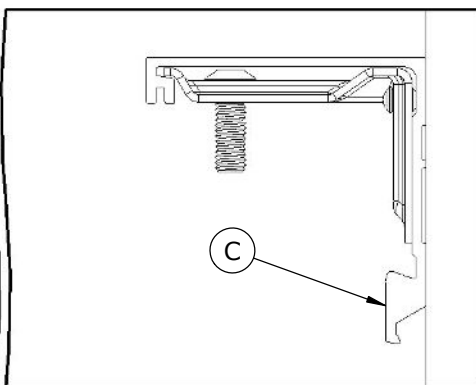
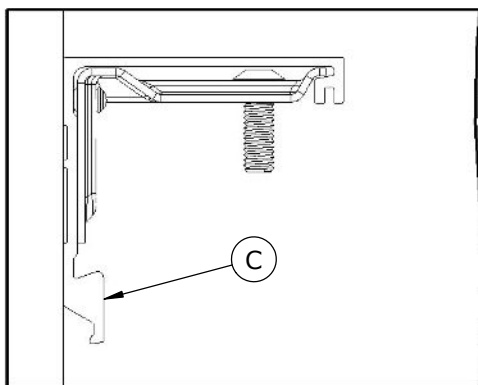
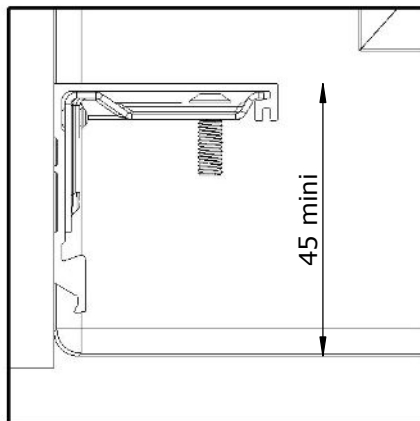

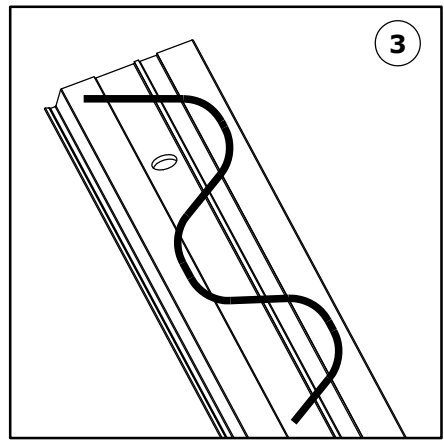
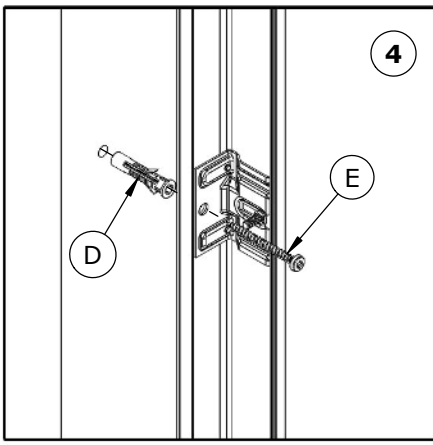
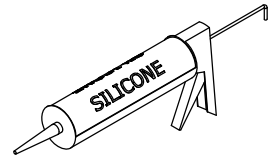
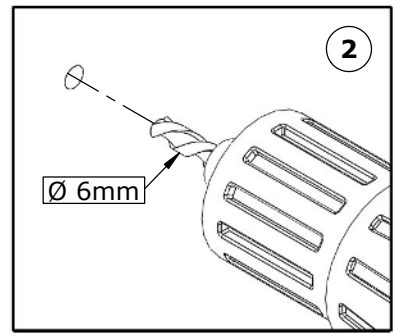
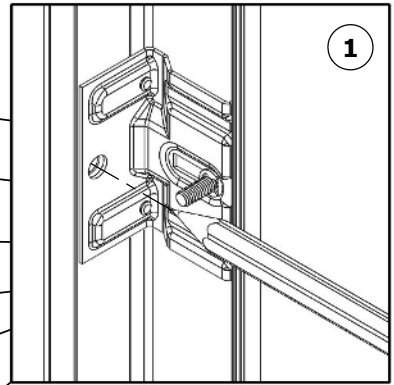
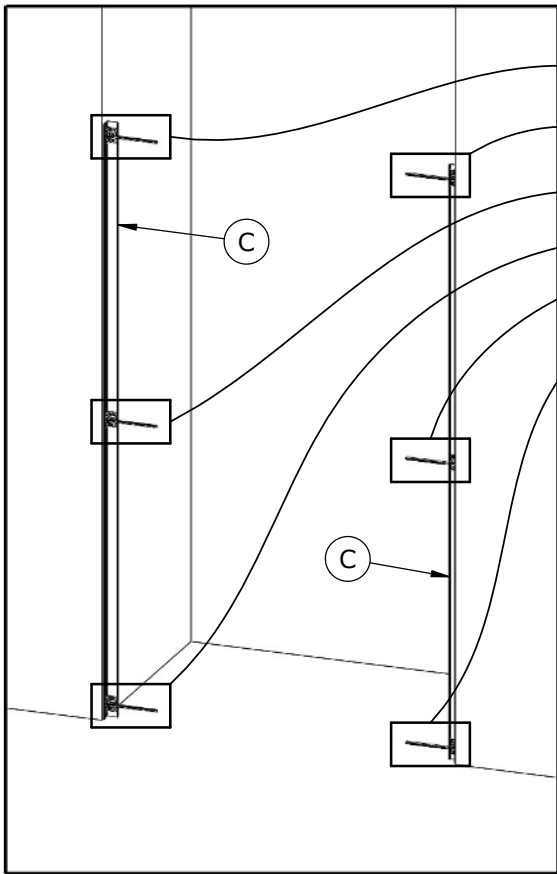

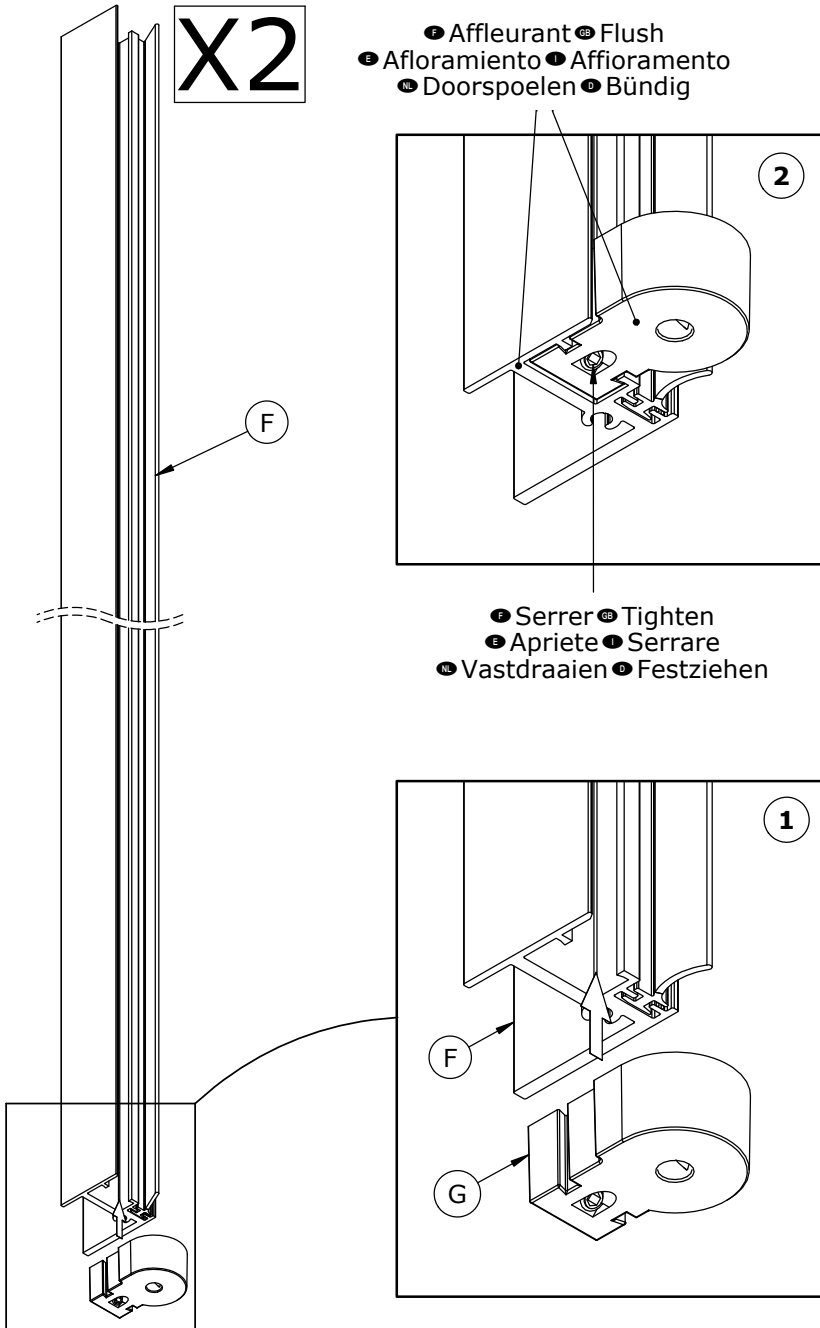

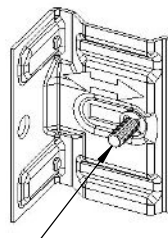
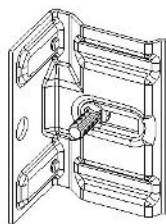
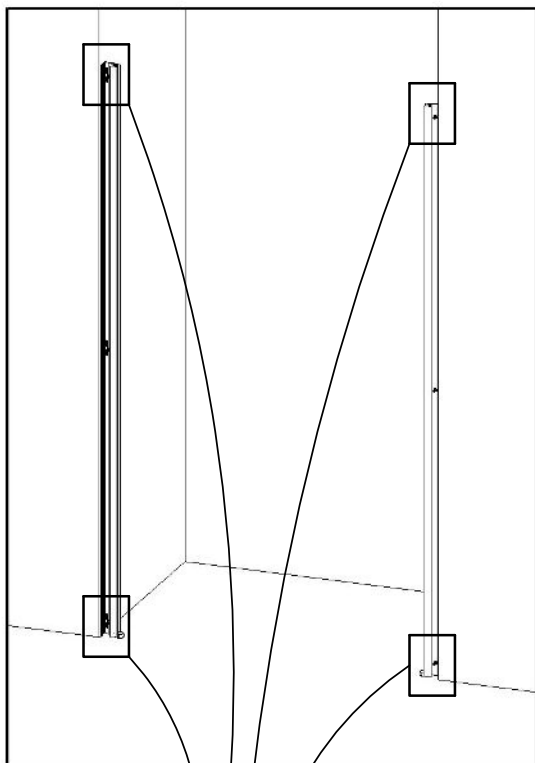

- Si nécessaire, desserrer, régler puis resserrer
- If necessary, loosen, adjust and retighten
- Si es necesario, afloje, ajuste y apriete
- Se necesario, allentare, regolare e stringere
- Draai los, indien nodig, stel af en draai vervolgens weer vast
- Falls erforderlich, lösen, einstellen und wieder festziehen

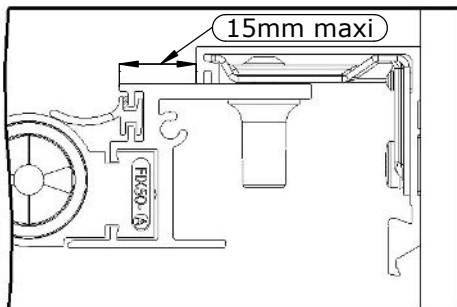
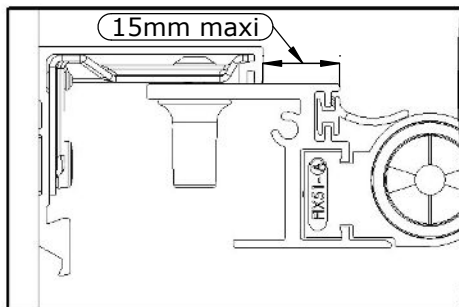
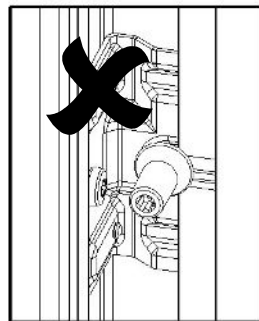
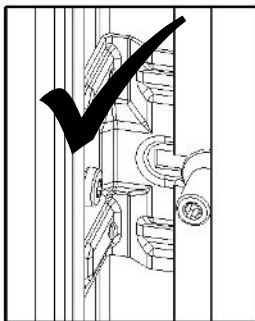
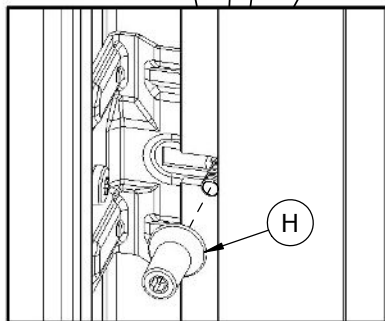



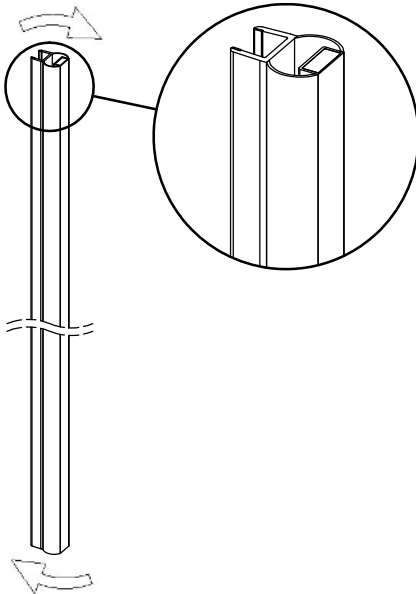
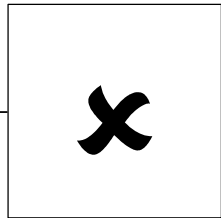
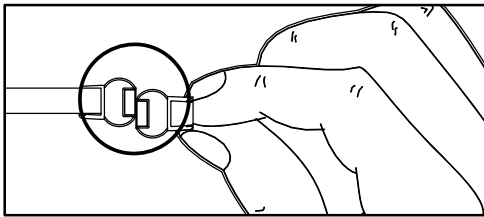
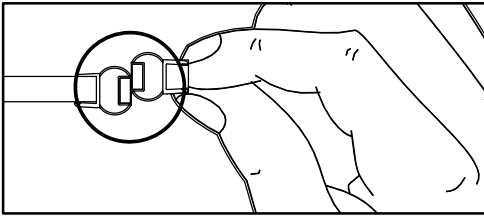
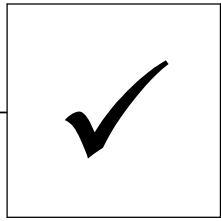
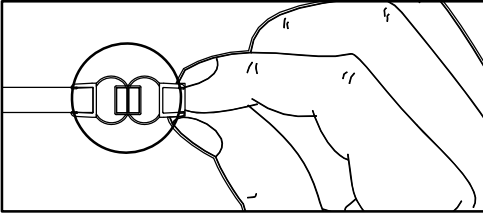

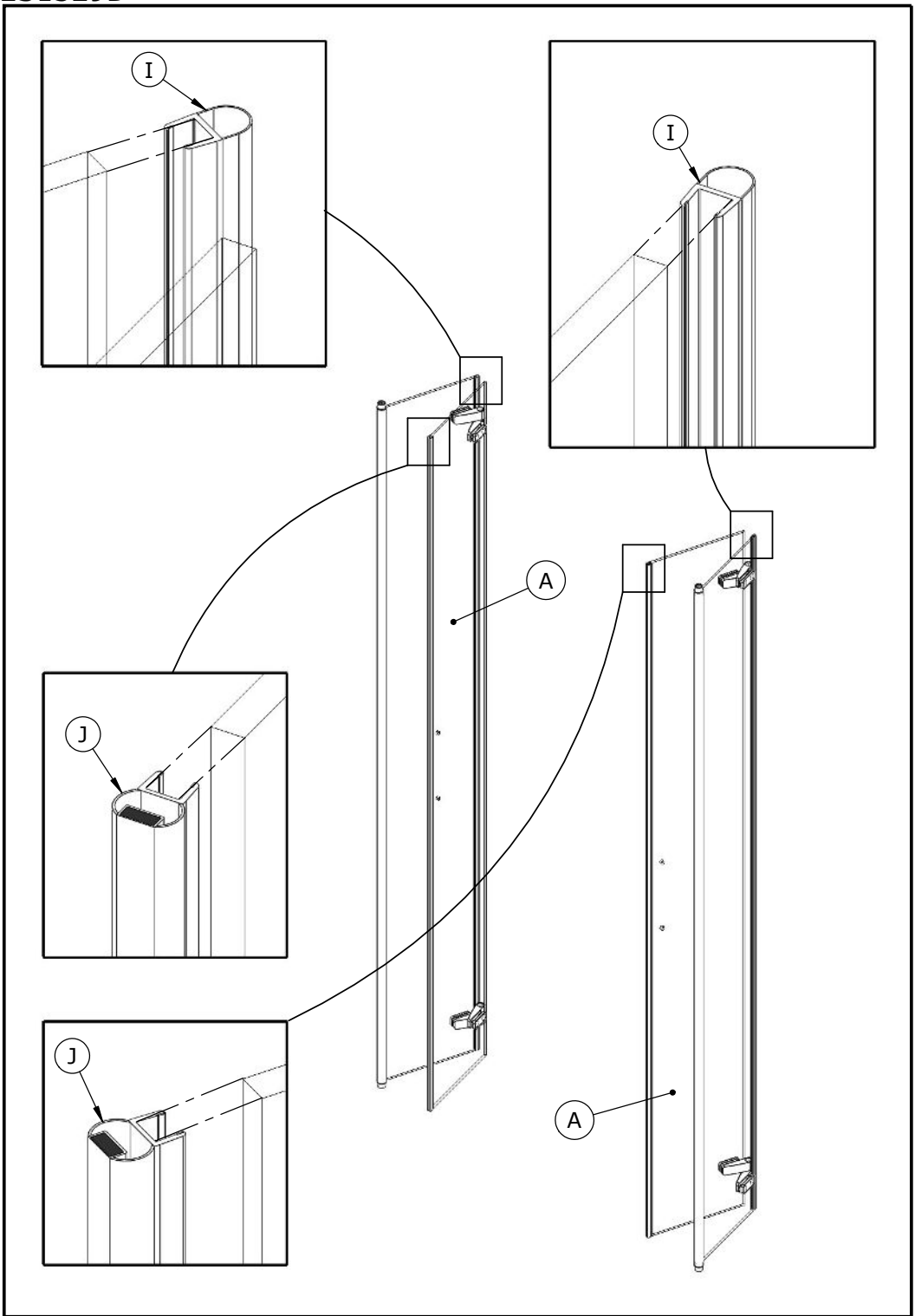

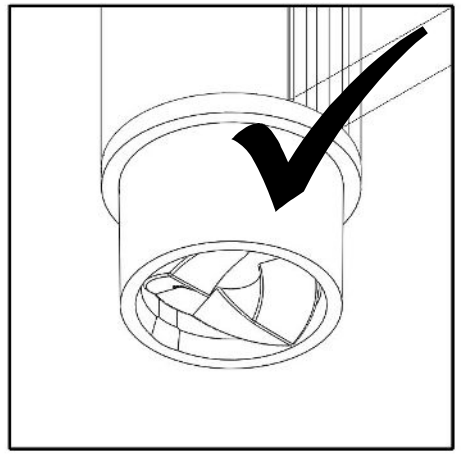
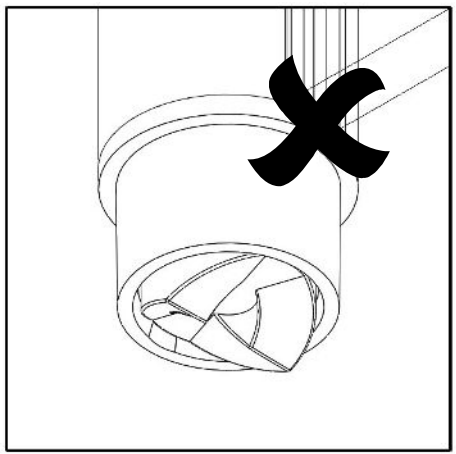
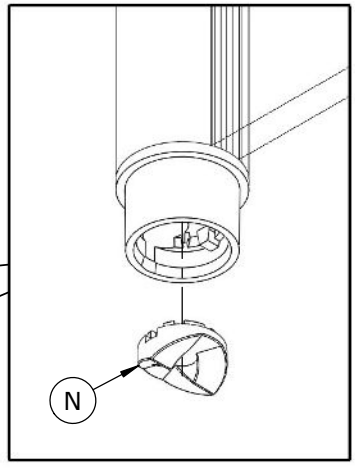
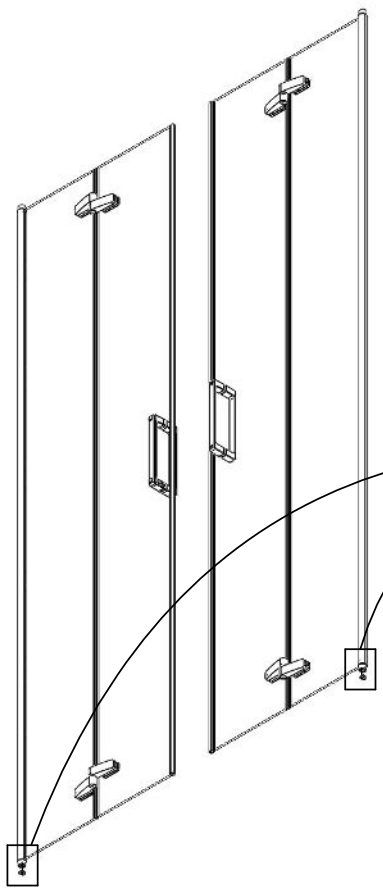

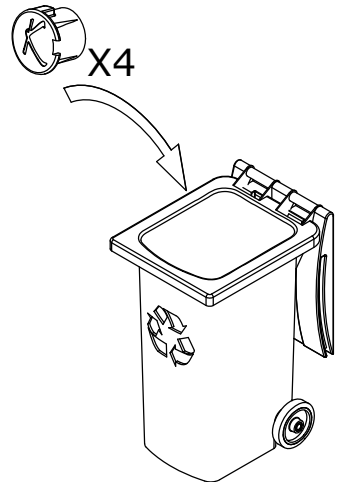
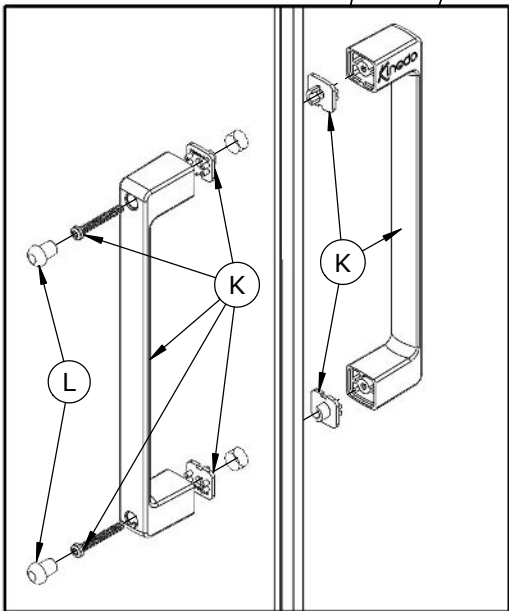
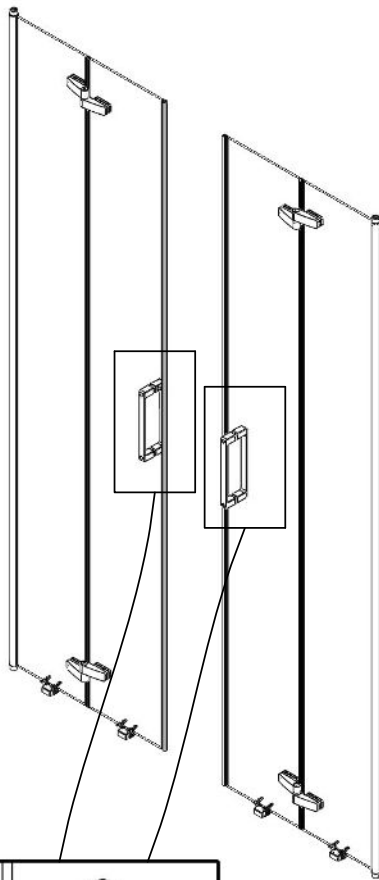

- Réglages des portes ● Adjusting the doors ● regolazione porte
- Deuren afstellen ● Ausrichten und Einstellen der Tür

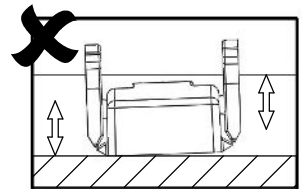
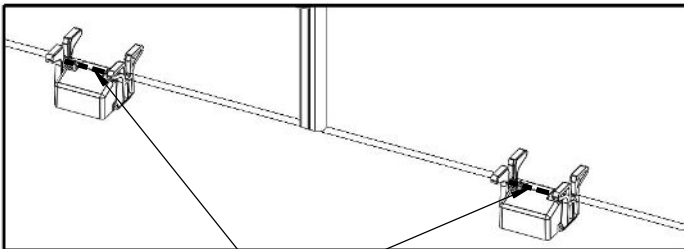
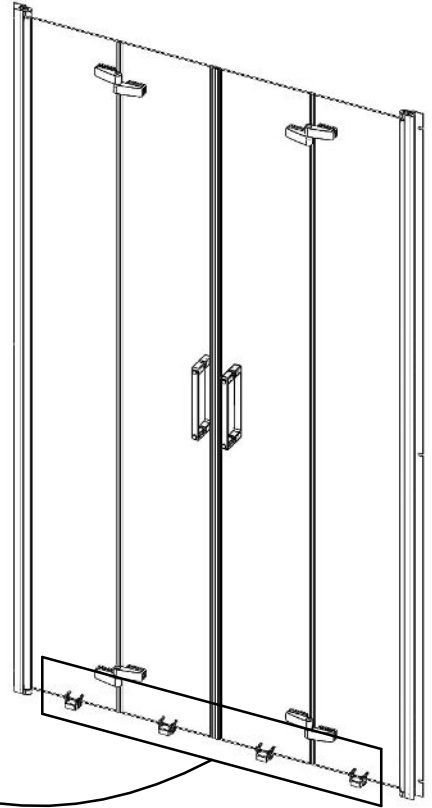
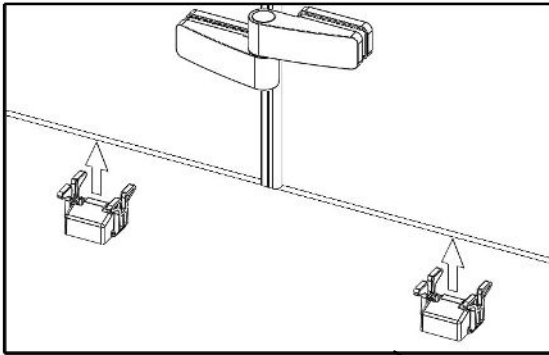
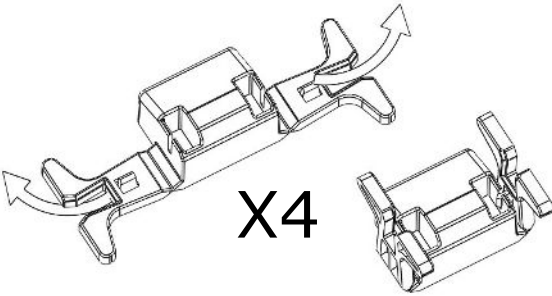

- Mettre en contact
- Put in contact
- Mettere in contatto
- Mensen in contact te brengen
- Kontakte knüpfen

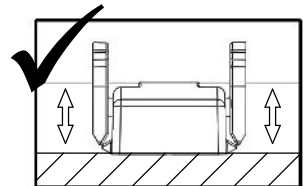

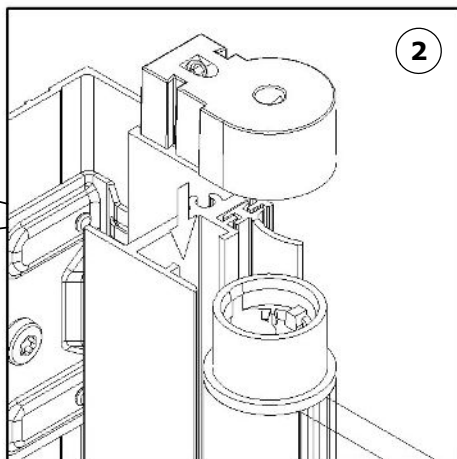
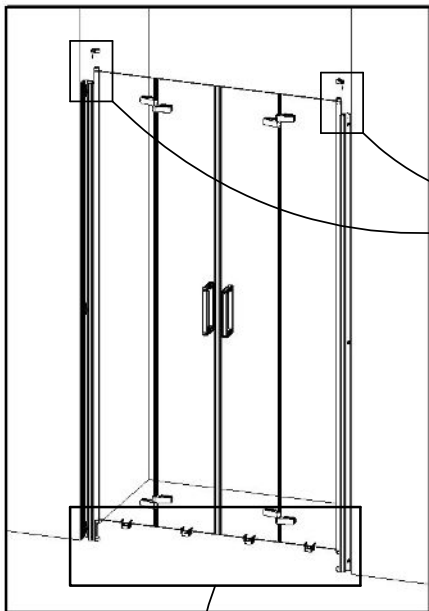

- F Affleurant ● G Flush
- E Afloramiento ● I Affioramento
- NL Doorspoelen ● D Bündig

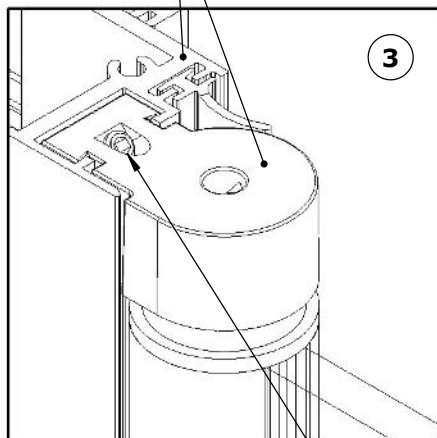
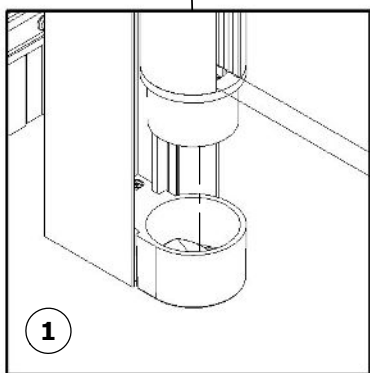

- F Serrer ● G Tighten
- E Apriete ● I Serrare
- NL Vastdraaien ● D Festziehen



- F Intérieur ● G Inside
- E Interior ● I Interno
- NL Binnenkant ● D Innen

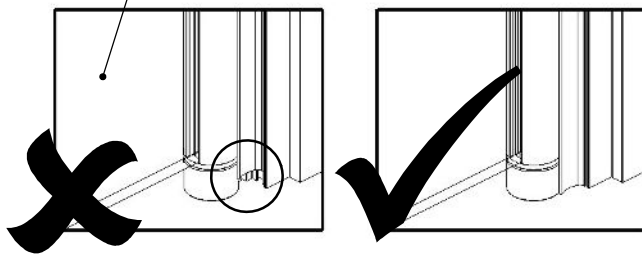

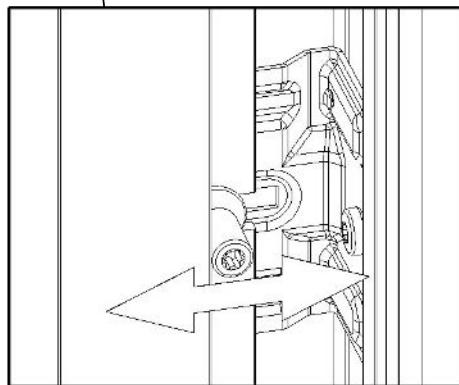
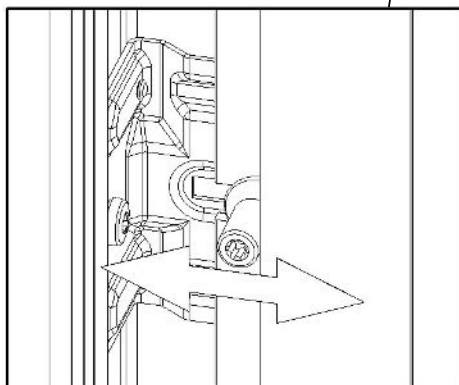
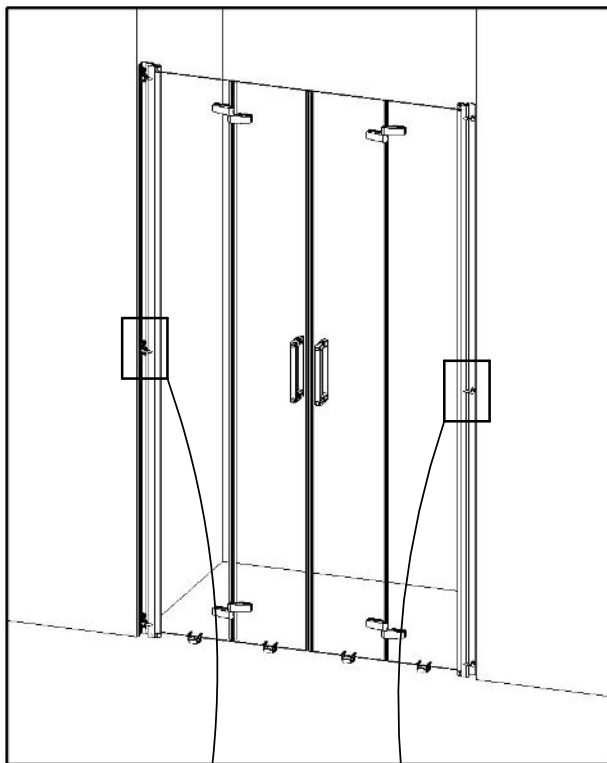

- Si nécessaire, desserrer, régler puis resserrer
- If necessary, loosen, adjust and retighten
- Si es necesario, afloje, ajuste y apriete
- Se necessario, allentare, regolare e stringere
- Draai los, indien nodig, stel af en draai vervolgens weer vast
- Falls erforderlich, lösen, einstellen und wieder festziehen

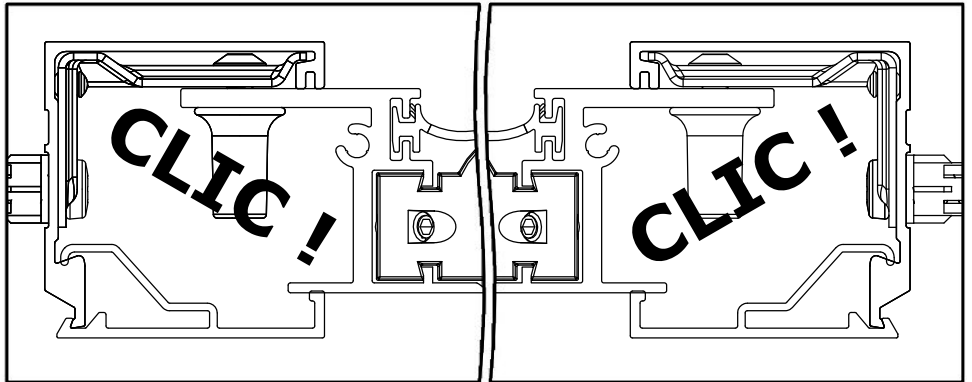
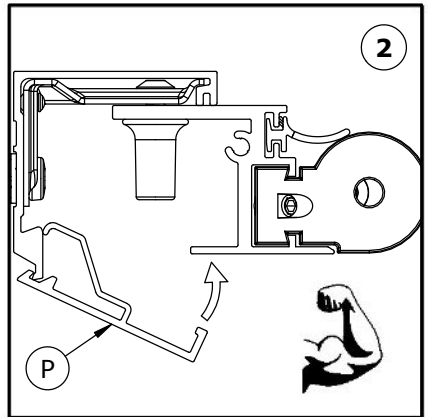
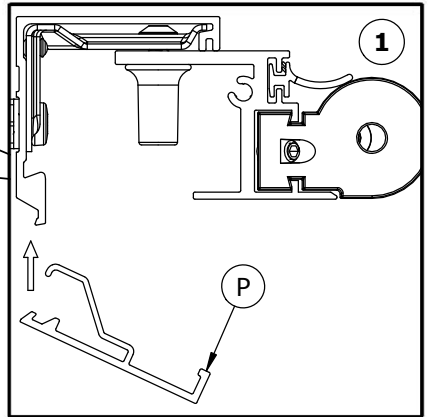
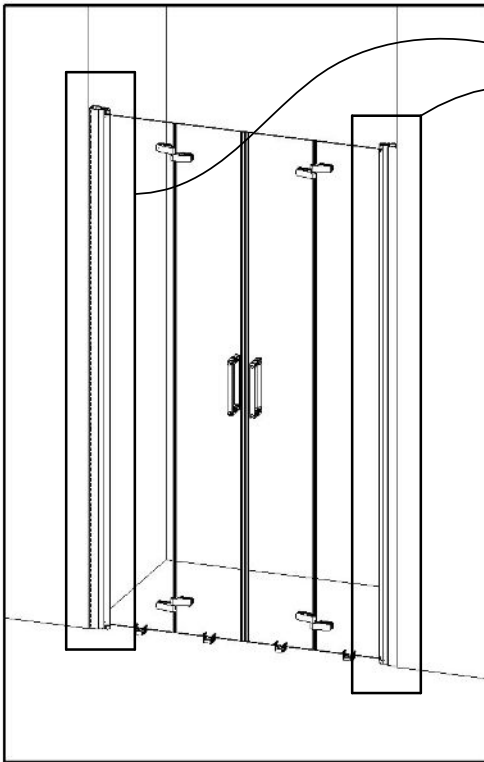



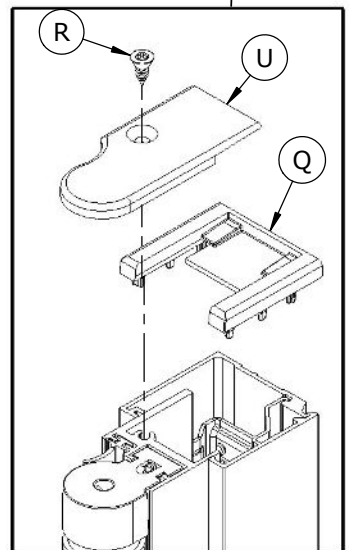
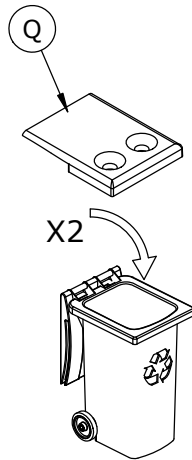
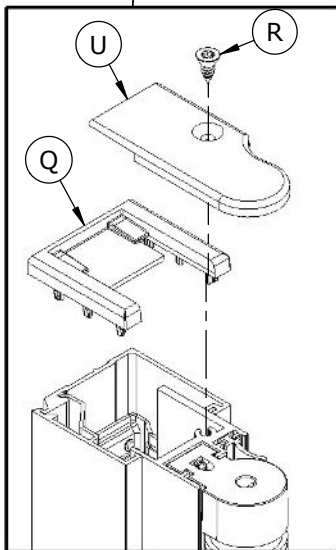
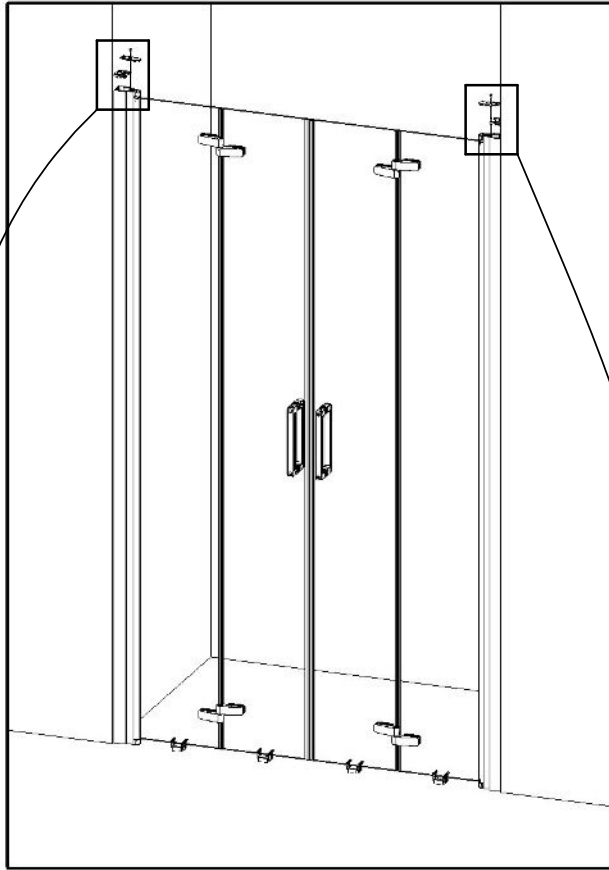

- Retirer (Q) ● Remove (Q) ● Togliere (Q)
- Verwijderen (Q) ● Entfernen (Q)

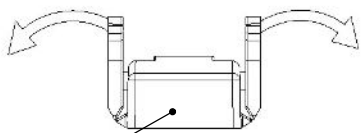

Q

X4

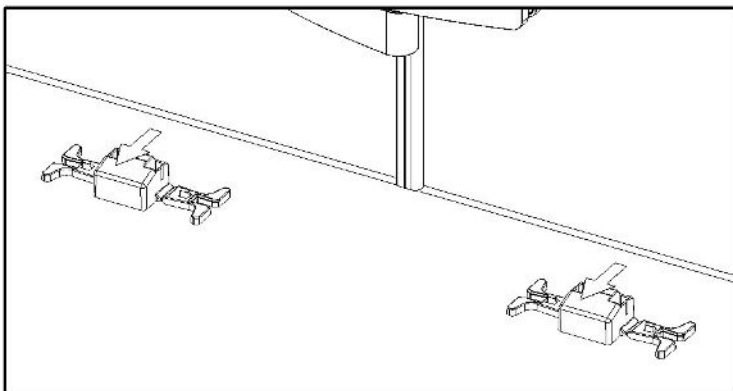
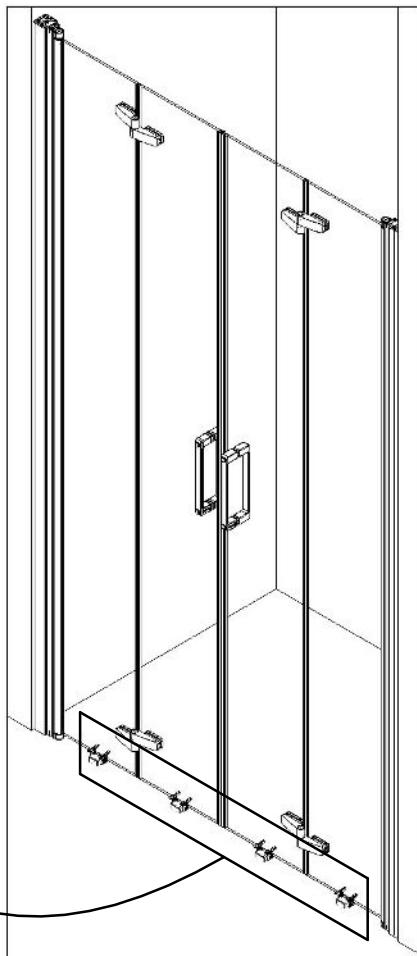
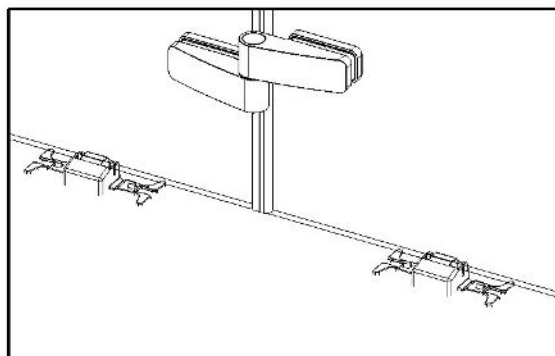

(F) Intérieur (GB) Inside  
 (E) Interior (I) Interno  
 (NL) Binnenkant (D) Innen



(M)

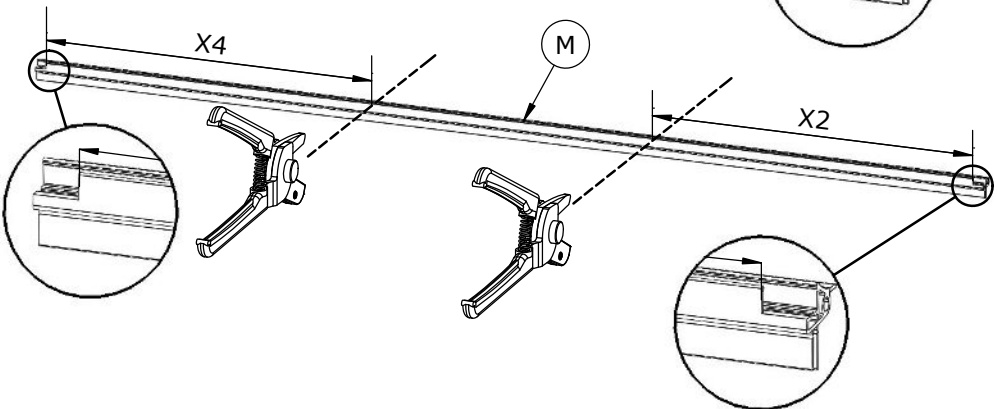
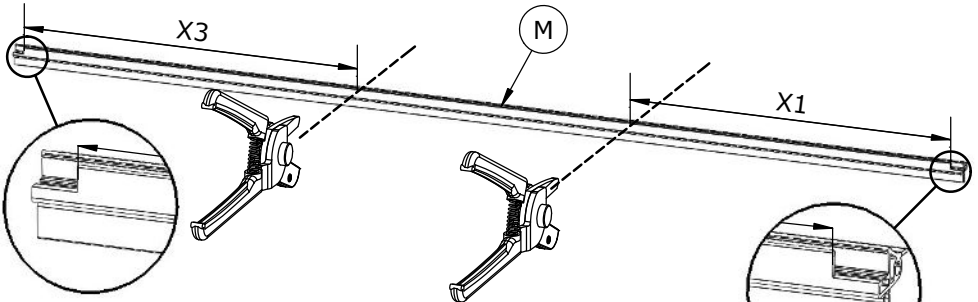
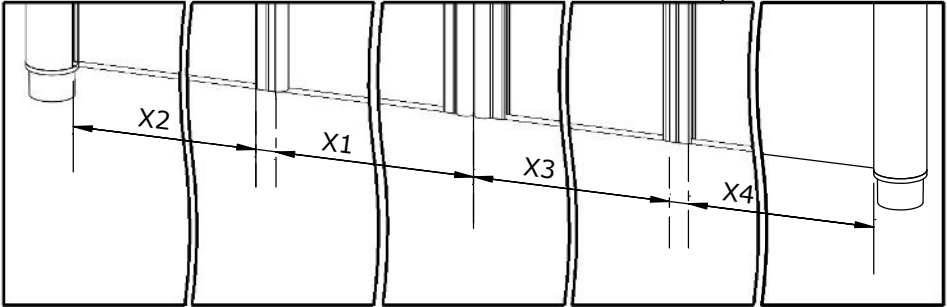
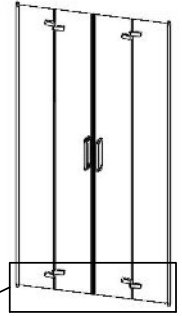
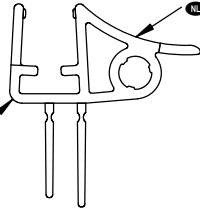



- Intérieur
- Ⓢ Inside
- Ⓔ Interior
- Interno
- Ⓜ Binnenkant
- Innen

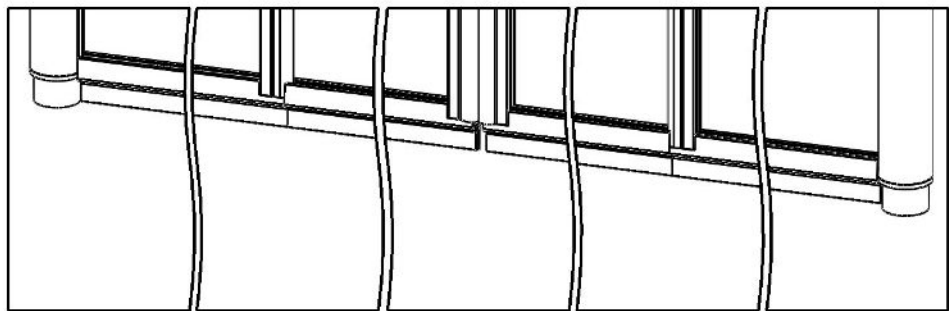
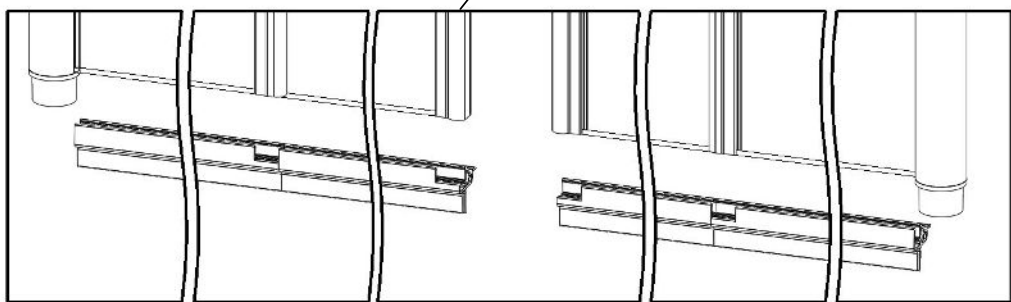
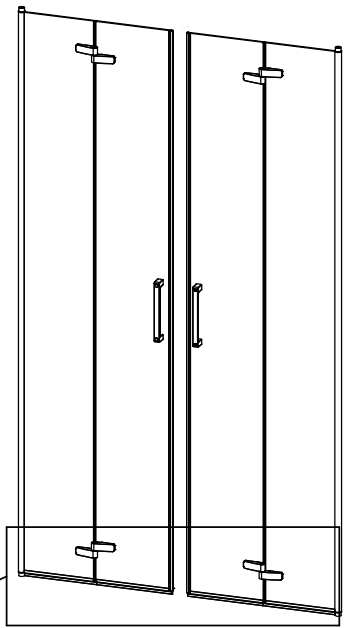
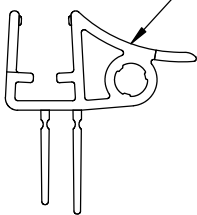

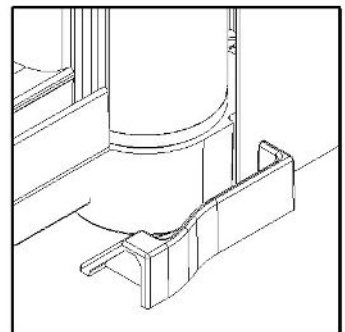
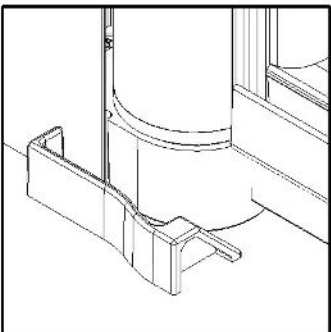
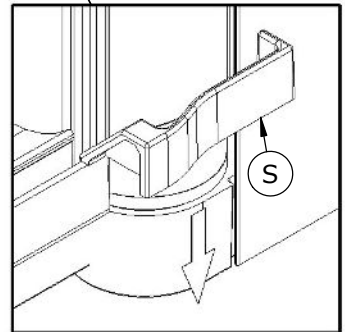
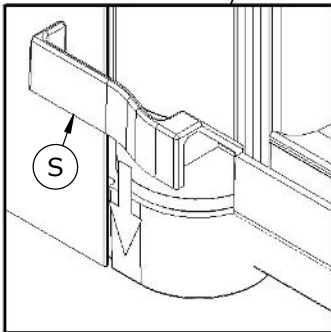
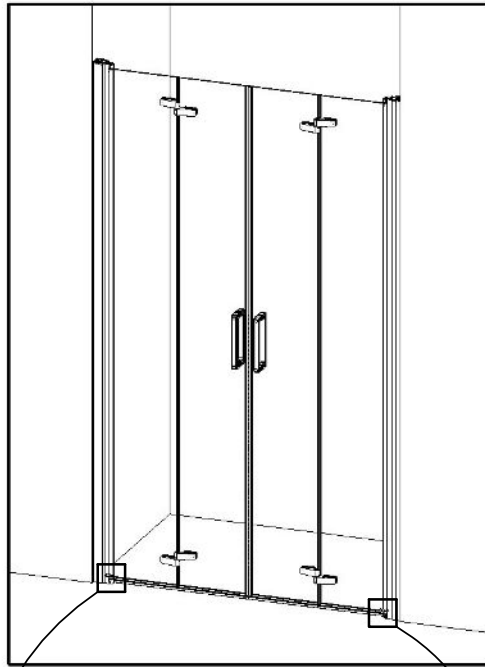

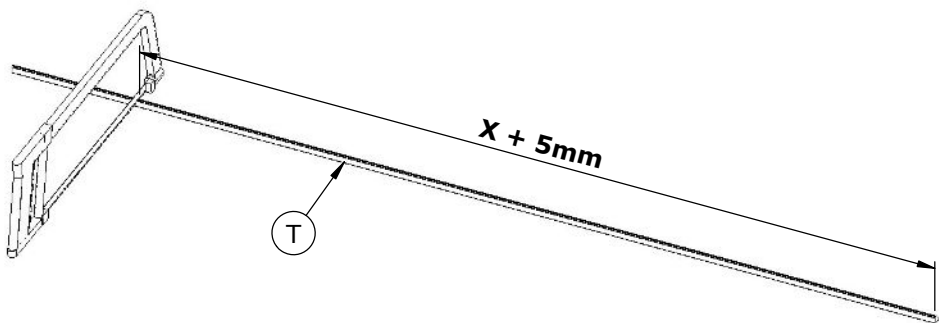
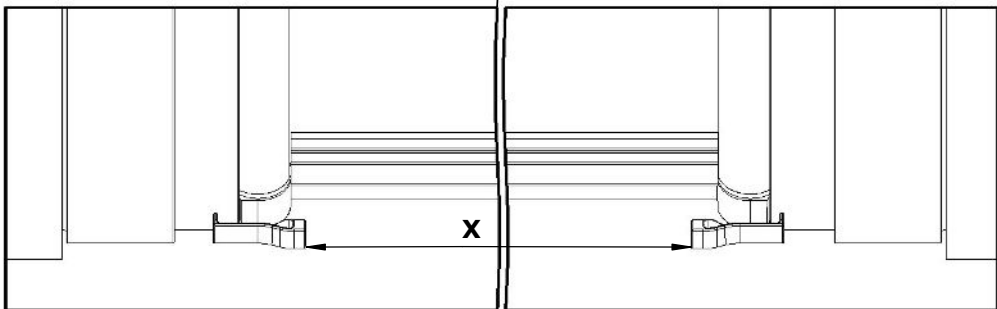
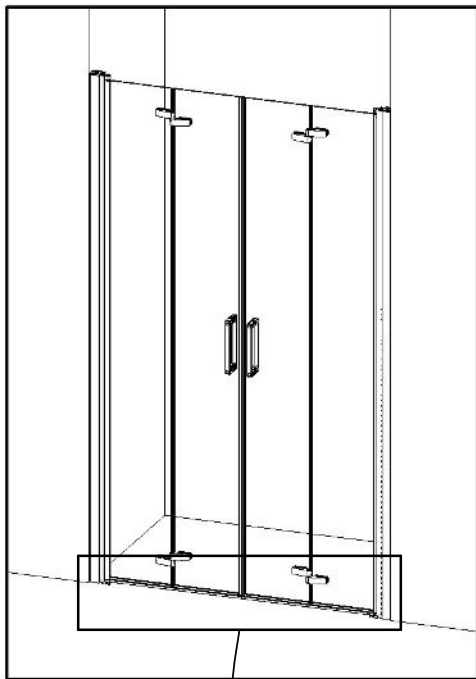

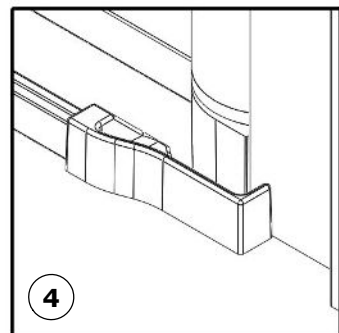
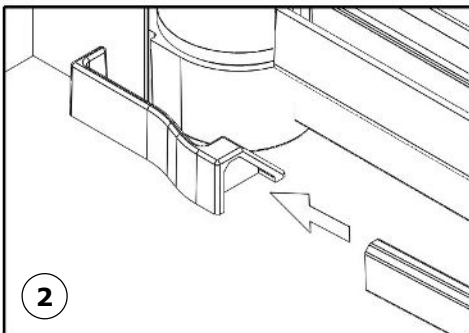
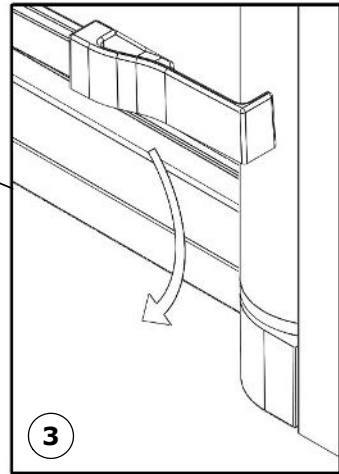
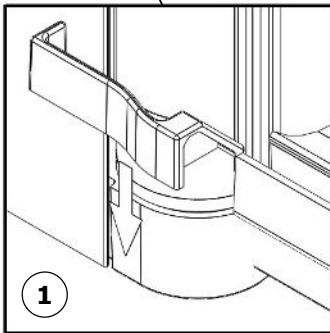
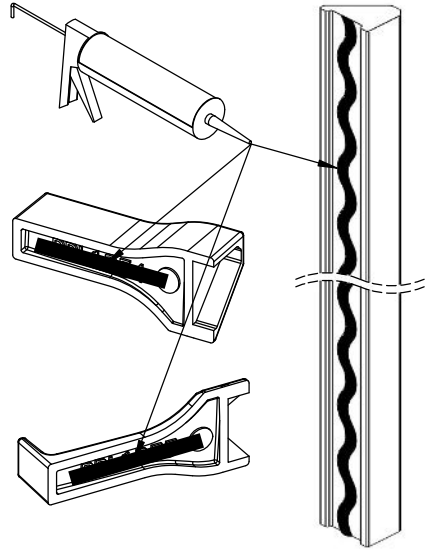
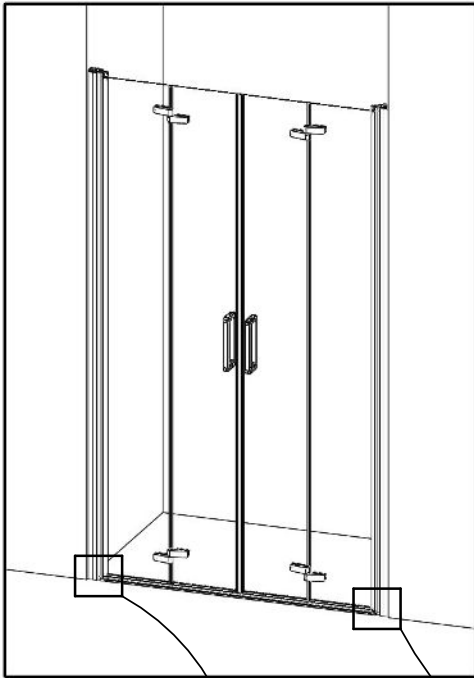

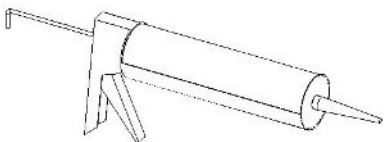

24H

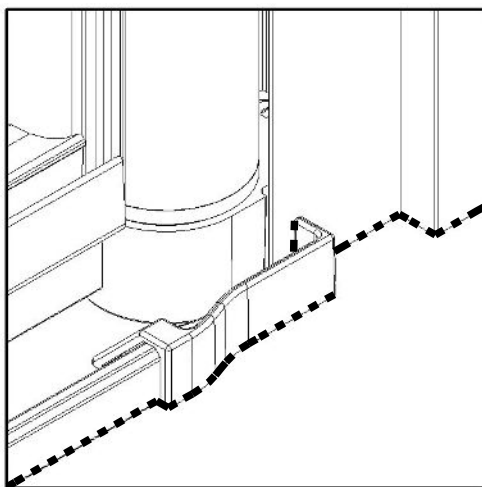
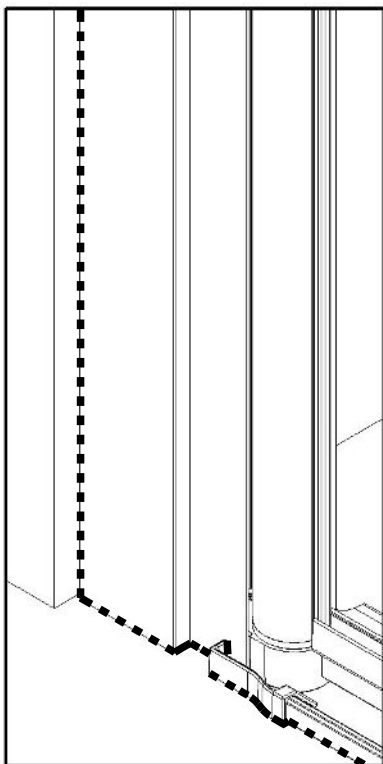
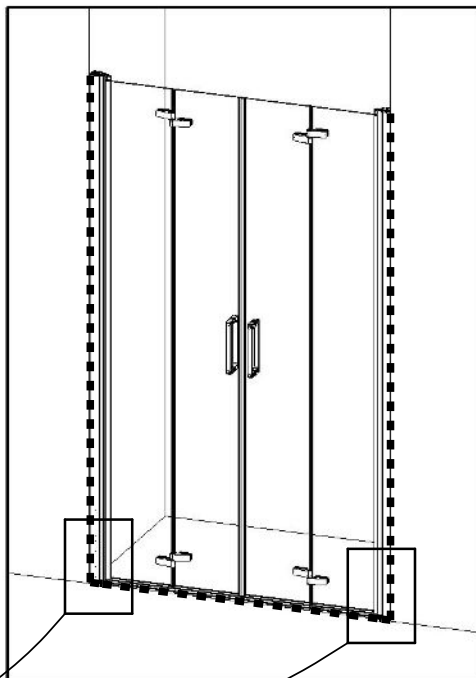







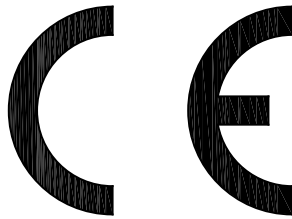

AQUAPRODUCTION, Site industriel,  
F - 44680 Chaumes-en-Retz

18

**EN 14428**

Paroi de douche, fabriquée en verre de silicate  
sodo-calcique de sécurité trempé thermiquement

Aptitude au nettoyage : réussite

Résistance à l'impact/propriétés de fragmentation : réussite

Durabilité : réussite



**SAV**  
**SERVICE HELPLINES**  
**ASSISTENZA POST-VENDITA**  
**SERVICIO POSTVENTA**

**FRANCE**

02 40 21 29 45

**SCHWEIZ**

(01) 748 17 44

**UK**

020 8842 0033

**ESPANA**

93 544 60 76

**IRELAND**

04697 33102

**NEDERLAND**

+31 475 487 100

**DEUTSCHLAND**

+49 (0) 6074 / 30928 0

**BELGIE**

+31 475 487 100

**ITALIA**

(0382) 6181

**BELGIQUE**

+31 475 487 100

**OSTEREICH**

+43 1 710 60 70

**РОССИЯ**

963 19 40, 773 67 22