

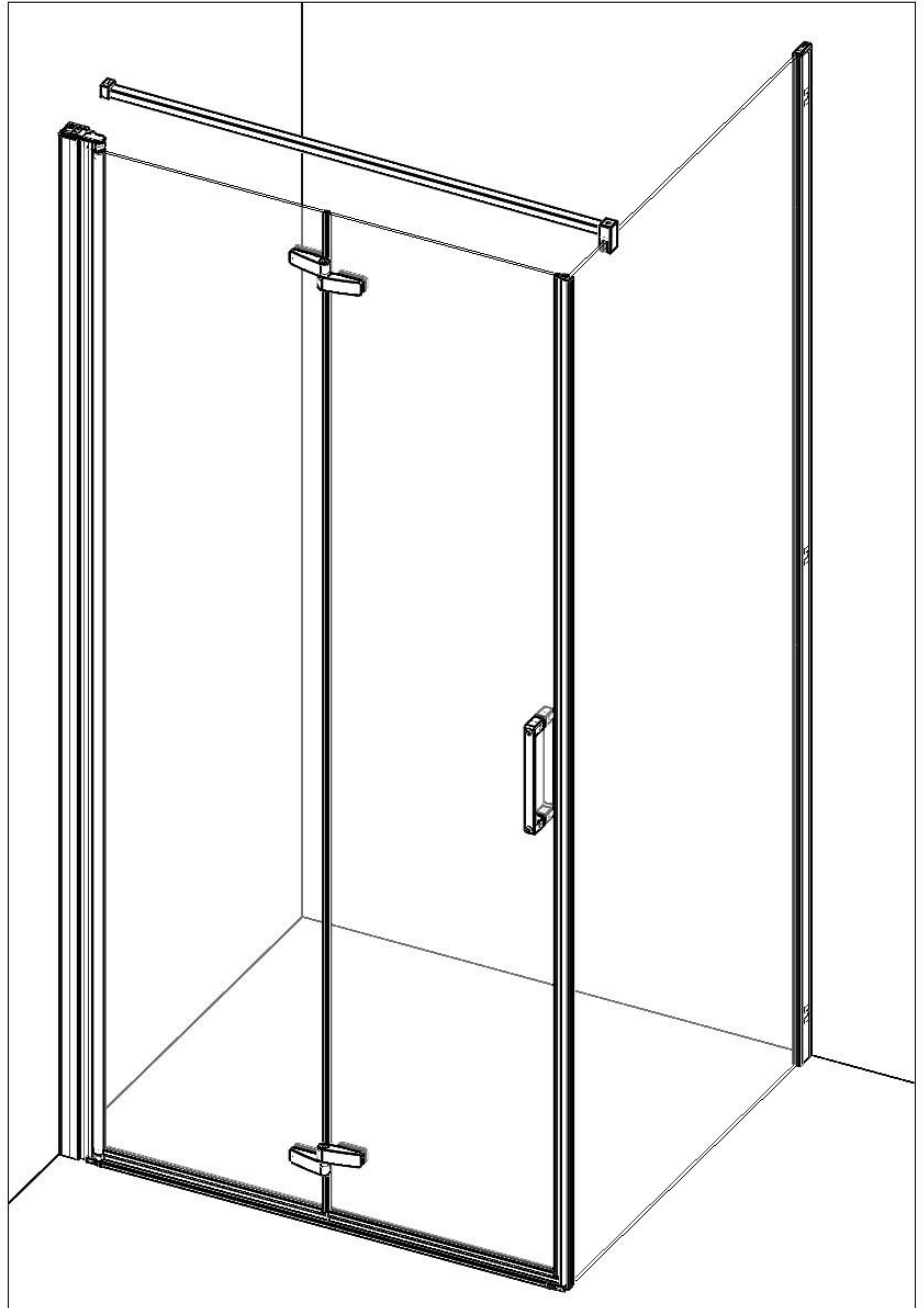

- F NOTICE DE MONTAGE
- GB INSTALLATION INSTRUCTIONS
- I ISTRUZIONI DI MONTAGGIO
- NL INSTALLATIE VOORSCHRIFTEN
- D INSTALLATIONSANLEITUNG





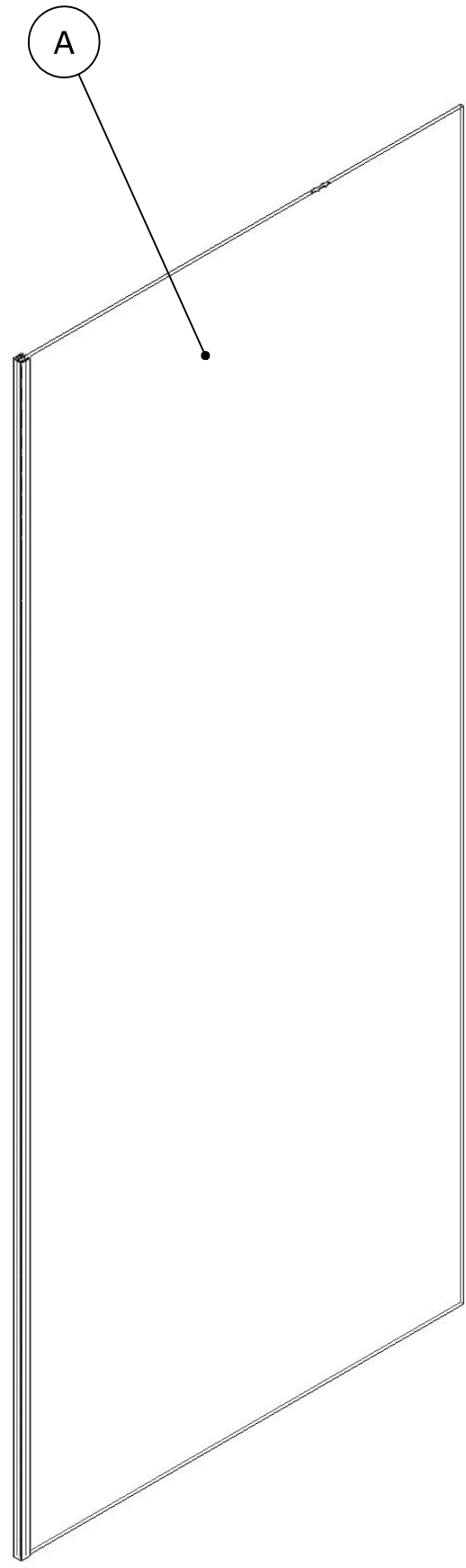
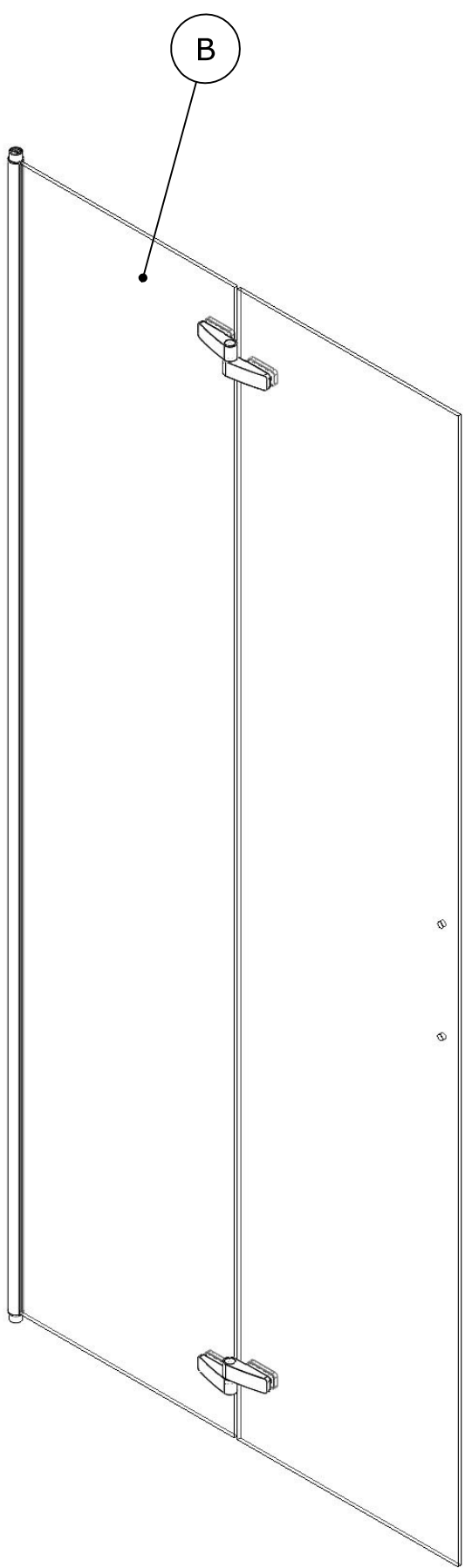

- F Attention aux étapes :
- GB Check installation steps :
- I Attenzione ai passi :
- NL Aandacht voor de stappen :
- D Achtung vor den Schritten :

P. 6 - 15 - 32

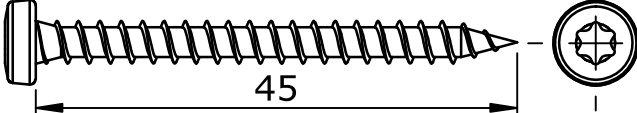
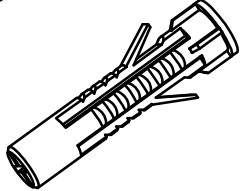

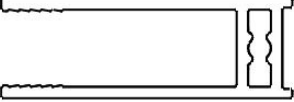
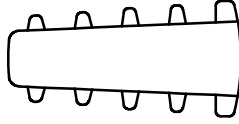
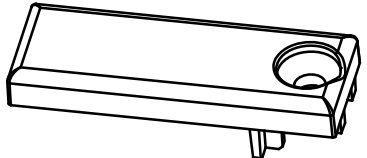
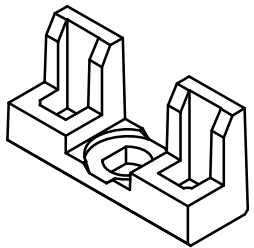
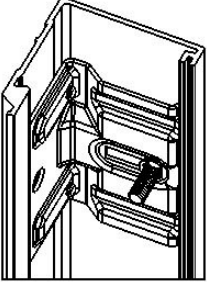
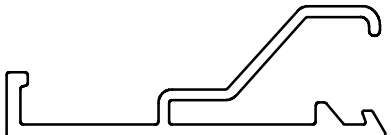
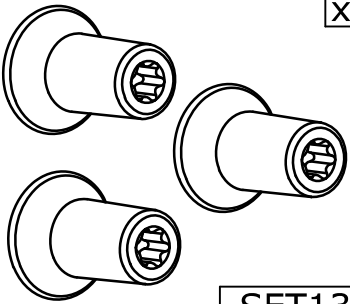
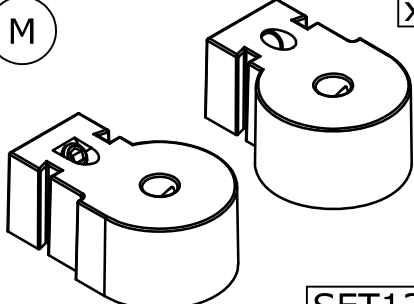
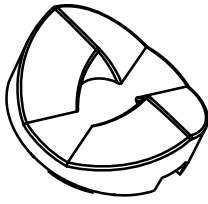
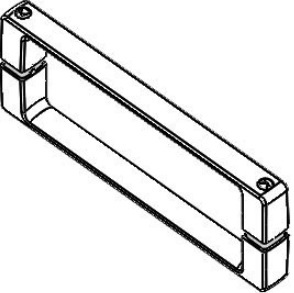
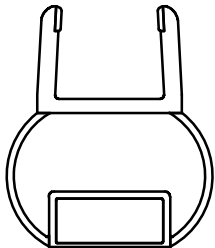
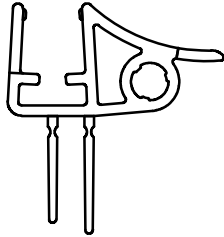
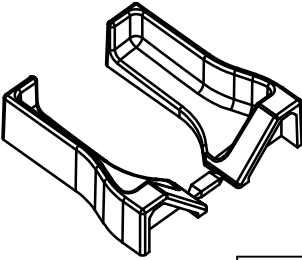
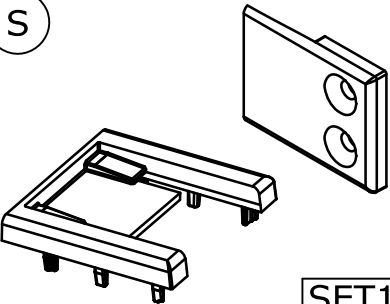
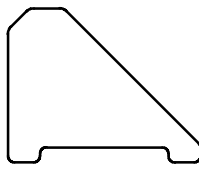
<p>C <math>\varnothing 3.5\text{mm}</math> x6</p>  <p>45</p> <p>VIS231</p>	<p>D x6</p>  <p>9,50</p> <p>CHE02</p>	<p>E <math>\varnothing 3.5\text{mm}</math> x2</p>  <p>9,50</p> <p>VIS261</p>
<p>F x1</p>  <p>6239</p>	<p>G x1</p>  <p>JOI299</p>	<p>H x1</p>  <p>PPL1266</p>
<p>I x3</p>  <p>PPL1196</p>	<p>J x1</p>  <p>6268</p>	<p>K x1</p>  <p>6270</p>
<p>L x1</p>  <p>SET134</p>	<p>M x1</p>  <p>SET128</p>	<p>N x1</p>  <p>PPL1248</p>
<p>O x1</p>  <p>PGN49</p>	<p>P x1</p>  <p>Lg = 1962mm</p> <p>AI178</p>	<p>Q x2</p>  <p>J806</p>
<p>R x1</p>  <p>SET140</p>	<p>S x1</p>  <p>SET137</p>	<p>T x1</p>  <p>6285</p>

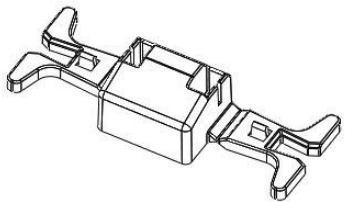
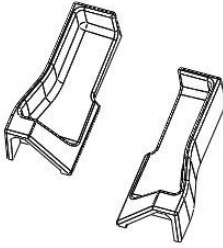
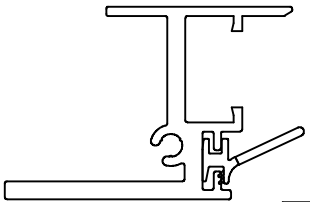
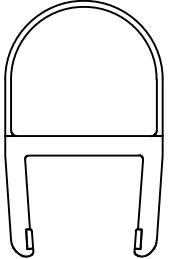
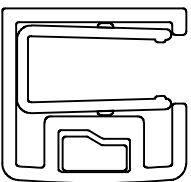
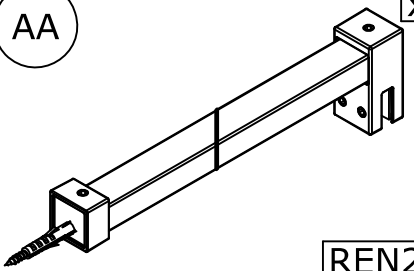
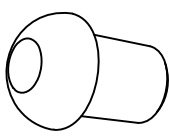
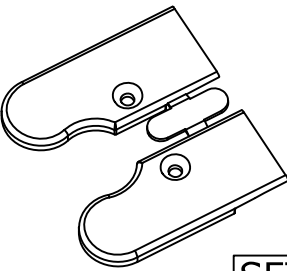
<p>V x2</p>  <p>PPL1339</p>	<p>W x1</p>  <p>SET139</p>	<p>X x1</p>  <p>6272</p>
<p>Y x1</p>  <p>Lg = 1962mm</p> <p>J808</p>	<p>Z x1</p>  <p>6284</p>	<p>AA x1</p>  <p>REN25</p>
<p>AB x2</p>  <p>BUT44</p>	<p>AC x1</p>  <p>SET174</p>	

- Les quantités données sont les quantités utiles au montage. les sachets fournis contiennent des pièces supplémentaires.
- The quantities given are what are required for the installation. There may be some surplus in the package provide.
- Le quantità fornite sono le quantità necessarie al montaggio. I sacchetti forniti contengono pezzi supplementari.
- De aangegeven aantallen zijn bestemd voor de montage. De bijgeleverde zakjes bevatten extra onderdelen.
- Die Mengenangaben beziehen sich auf die für die Montage nötigen Teile. Eventuell weitere beige packte Teile ignorieren.

## F Matériel nécessaire GB Tools required

## I Materiale necessario NL Benodigd gereedschap D Benötigte Werkzeuge

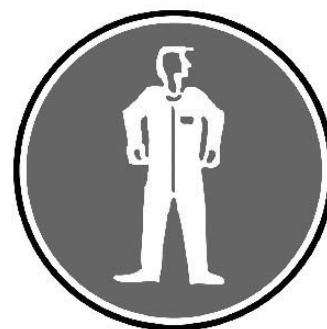
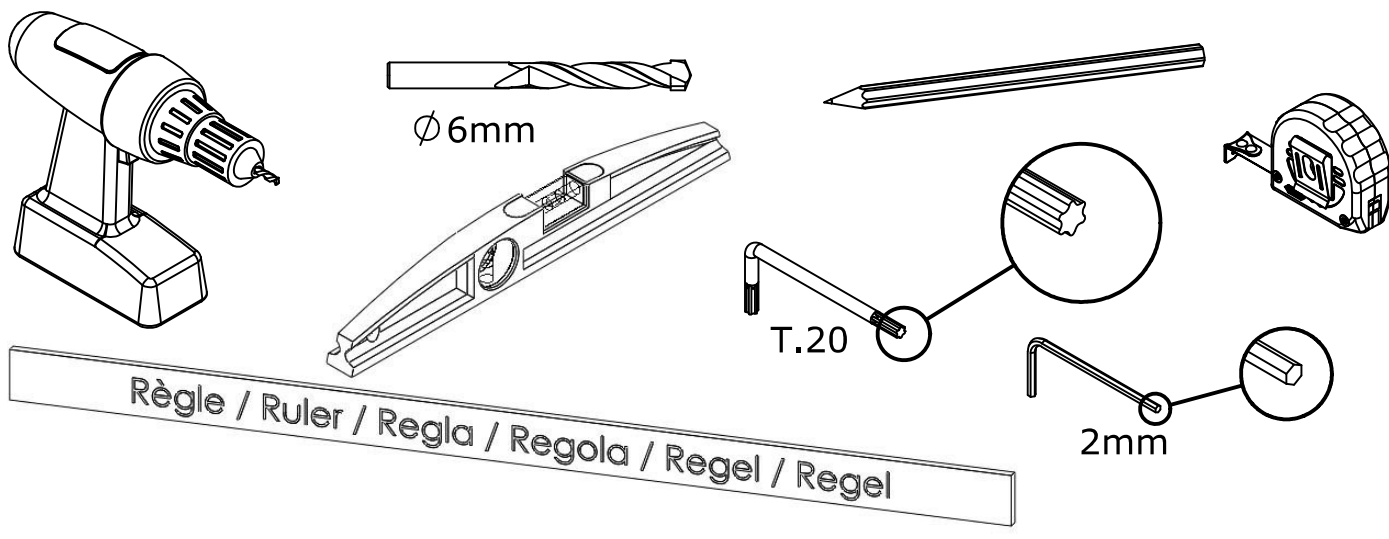

● REVERSIBILITE ● REVERSIBILITY  
 ● REVERSIBILITA ● OMKEERBAARHEID ● WAHLWEISE MONTAGE

● MONTAGE A GAUCHE  
 ● LEFT HAND  
 ● MONTAGGIO A SINISTRA  
 ● MONTAGE LINKS  
 ● MONTAGE LINKS

● MONTAGE A DROITE  
 ● RIGHT HAND  
 ● MONTAGGIO A DESTRA  
 ● MONTAGE RECHTS  
 ● MONTAGE RECHTS

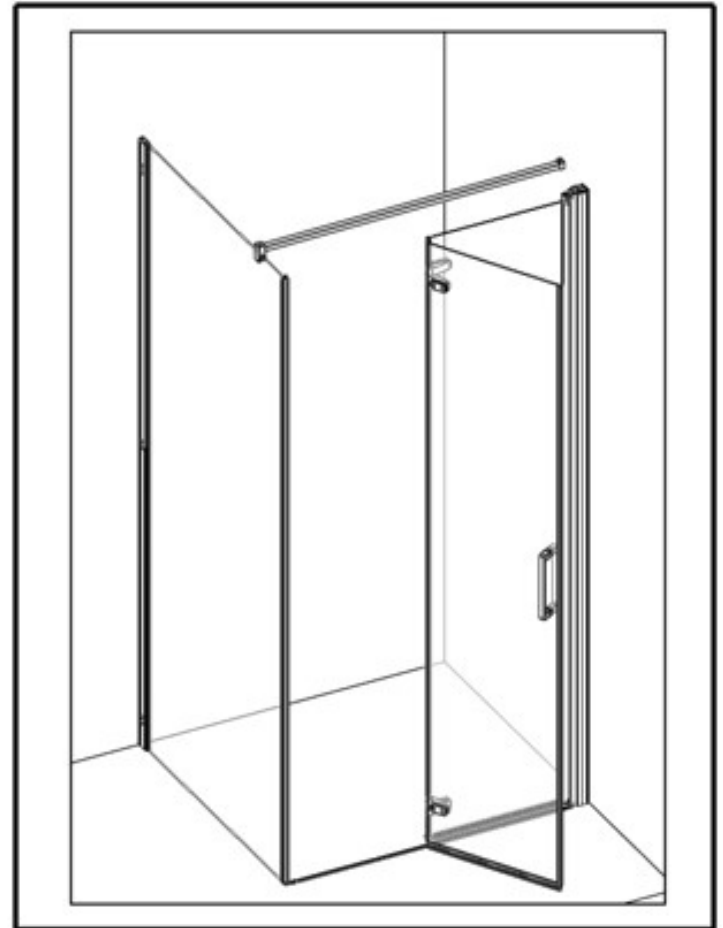
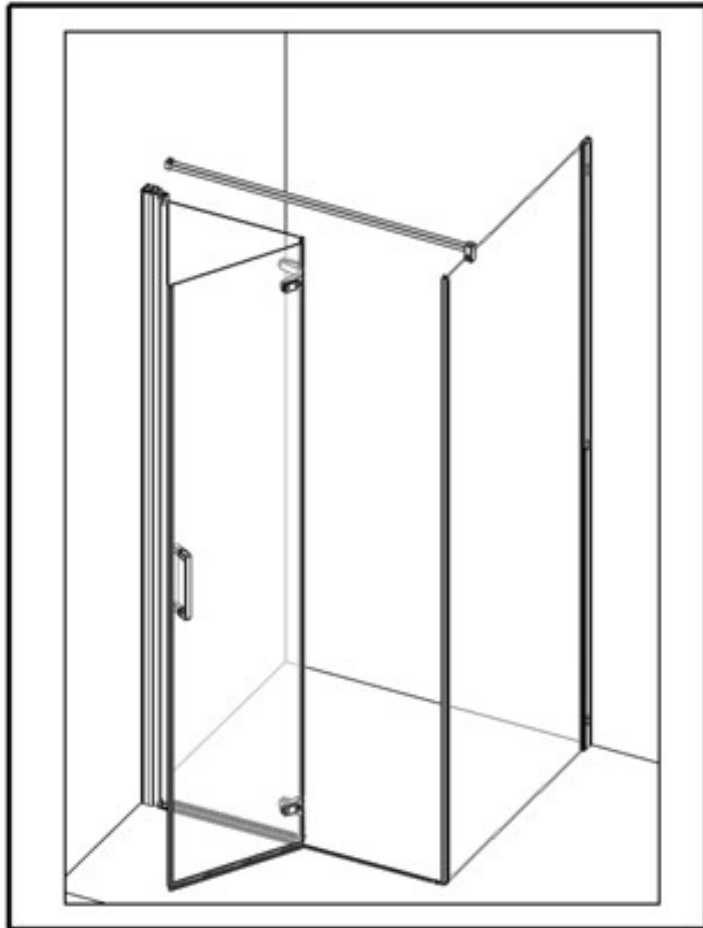

● Vous avez la possibilité de réaliser un montage à droite ou un montage à gauche. Notre notice d'installation décrit un montage à gauche. Si vous voulez réaliser un montage à droite, il vous suffit d'inverser le montage.

● This cubicle can be installed either left or right hand. These installation instructions show a left hand installation.

● Avete la possibilità di effettuare il montaggio a destra o a sinistra. Il nostro manuale descrive il montaggio a sinistra. Se volete realizzare il montaggio a destra è sufficiente invertire varie fasi di montaggio.

● U kunt de douchecabine rechts of links monteren. Onze handleiding beschrijft de links montage van de cabine. Keer de montage om als u de cabine rechts wilt monteren.

● Sie haben die Möglichkeit, eine Montage auf der linken Seite oder eine Montage auf der rechten Seite durchzuführen. Unsere Montageanleitung beschreibt eine Montage auf der linken Seite. Wenn Sie die Montage lieber auf der rechten Seite durchführen wollen, müssen Sie nur den Montageprozess umkehren.

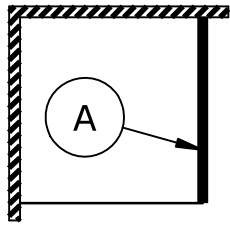
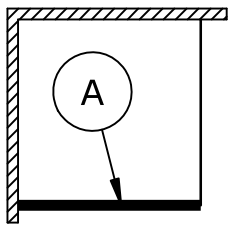

● F Si receveur ● GB If shower tray  
 ● Se piatto  
 ● NL Als douchebak ● D Wenn Duschwanne

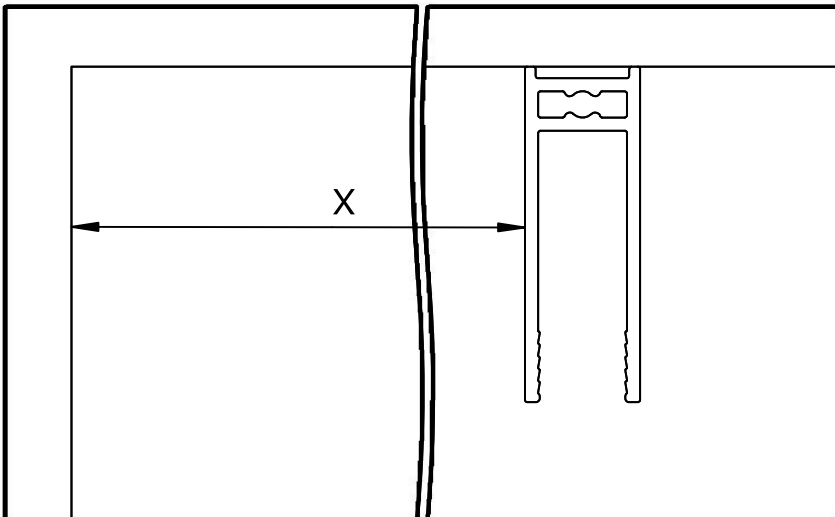
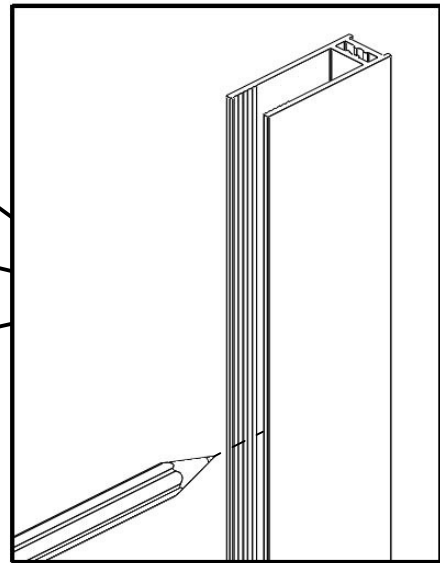
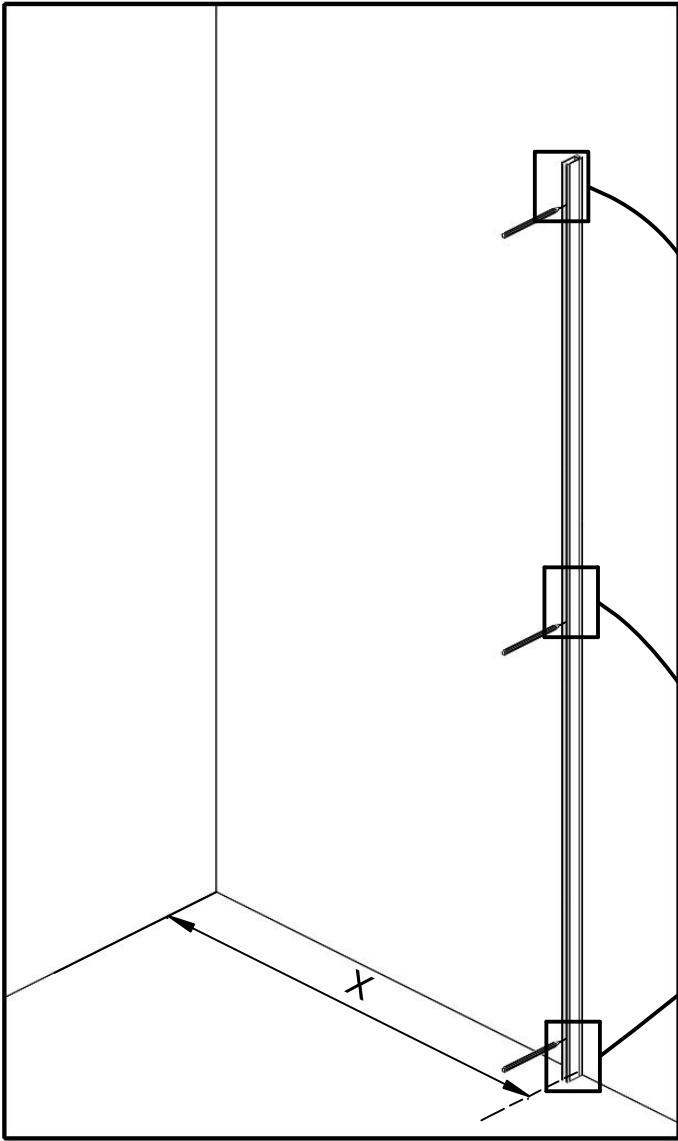
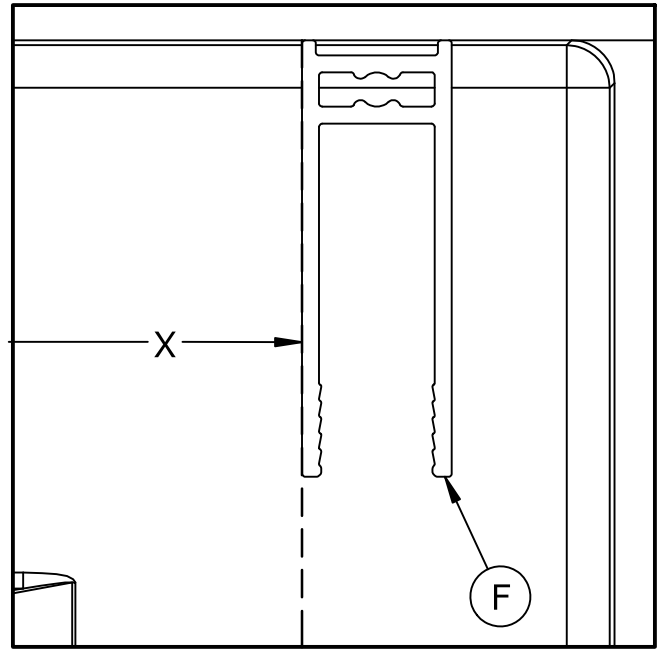

DIMENSIONS (cm)	X (mm)
70	656 - 671
75	706 - 721
80	756 - 771
85	806 - 821
90	856 - 871
95	906 - 921
100	956 - 971

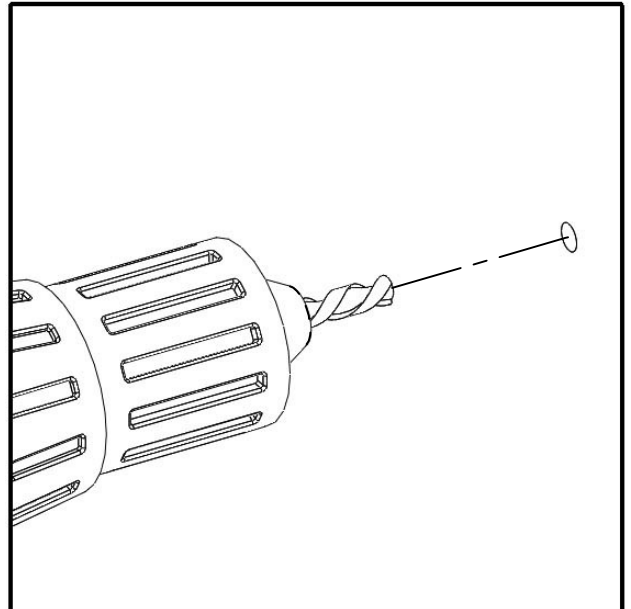
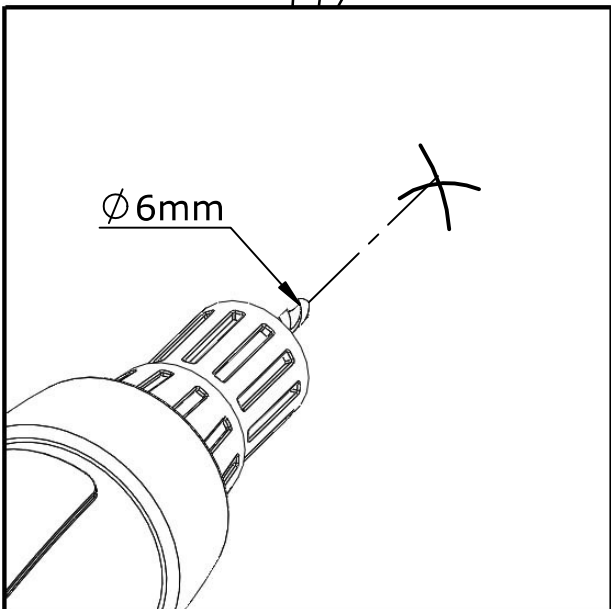
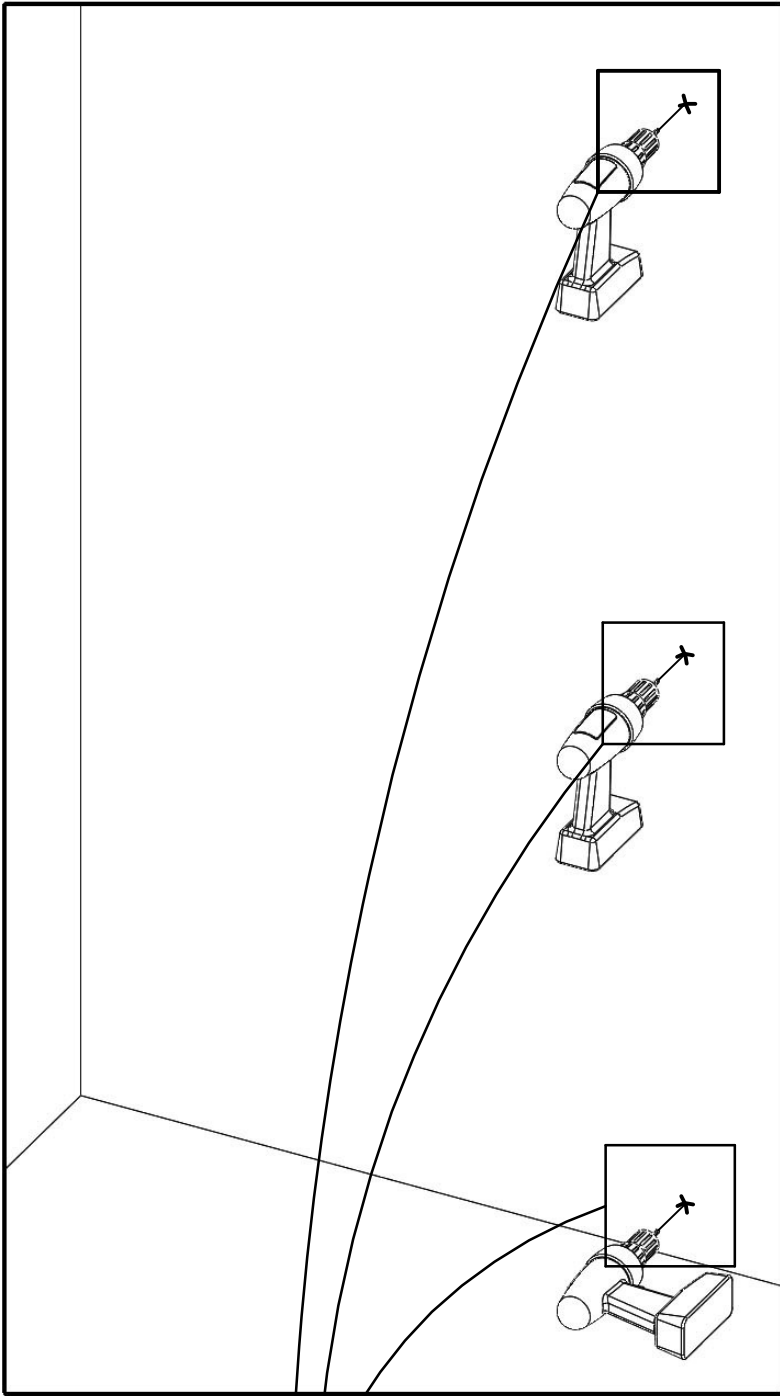

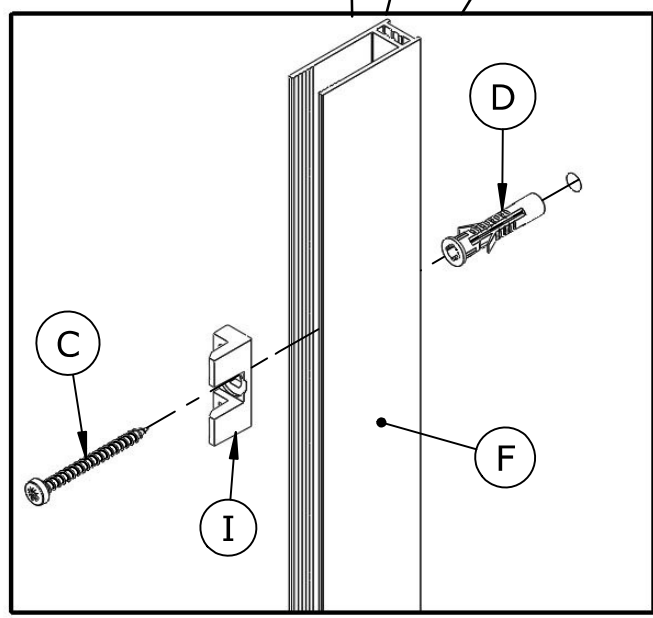
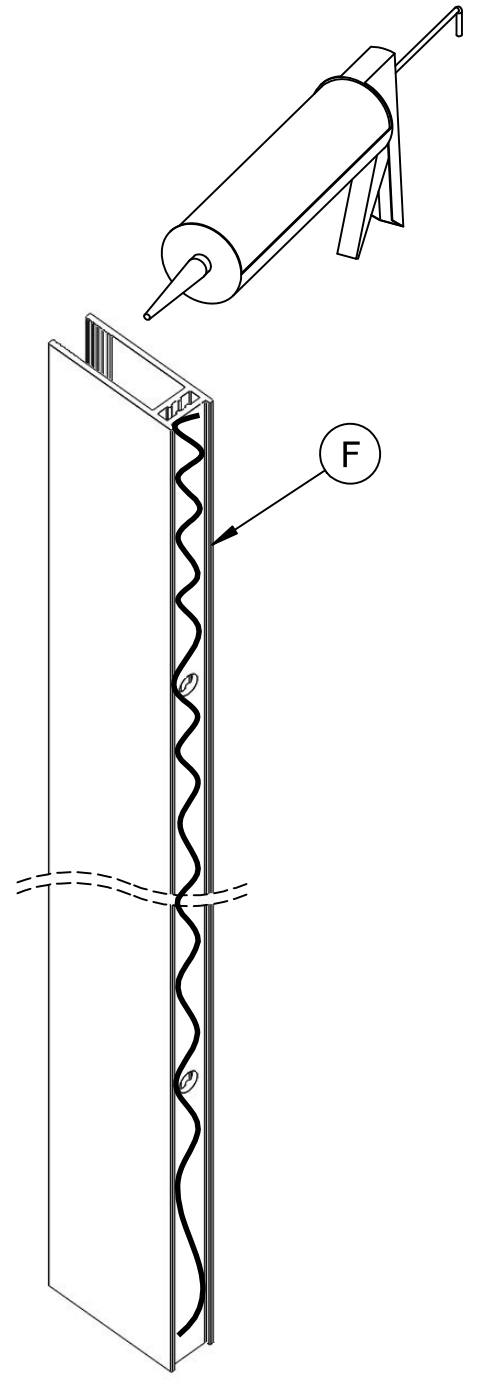
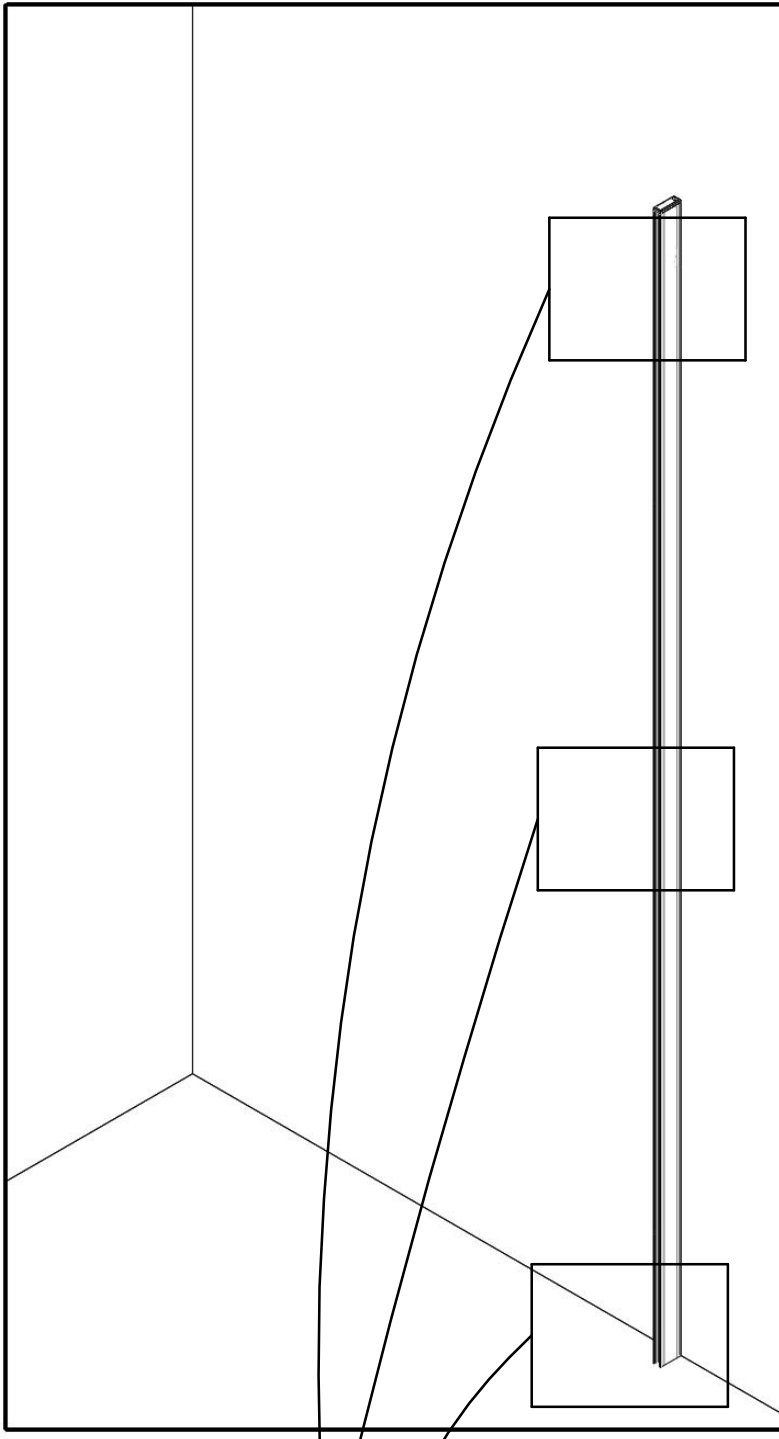

**F** Intérieur douche  
**GB** Inside shower  
**I** Doccia interni  
**NL** Binnenkant van de douche  
**D** Innenraum der Kabine



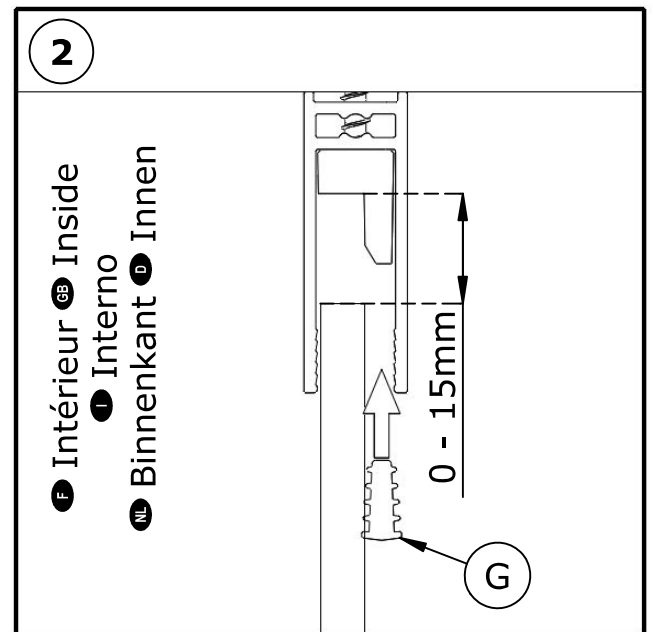
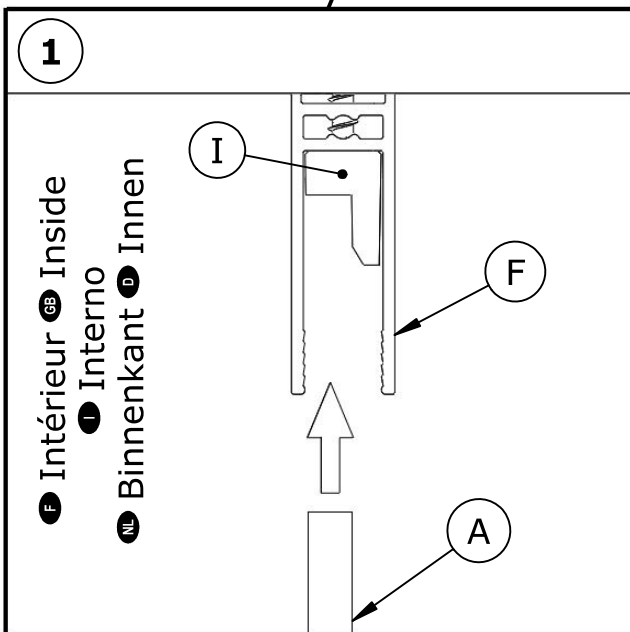
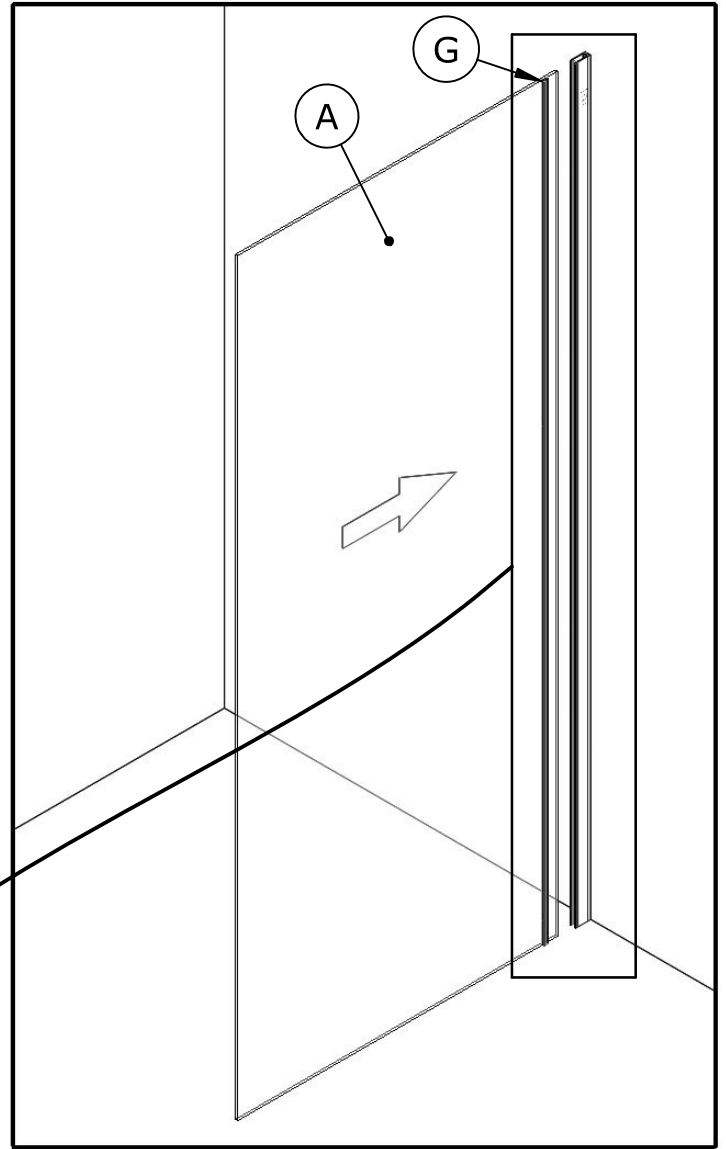
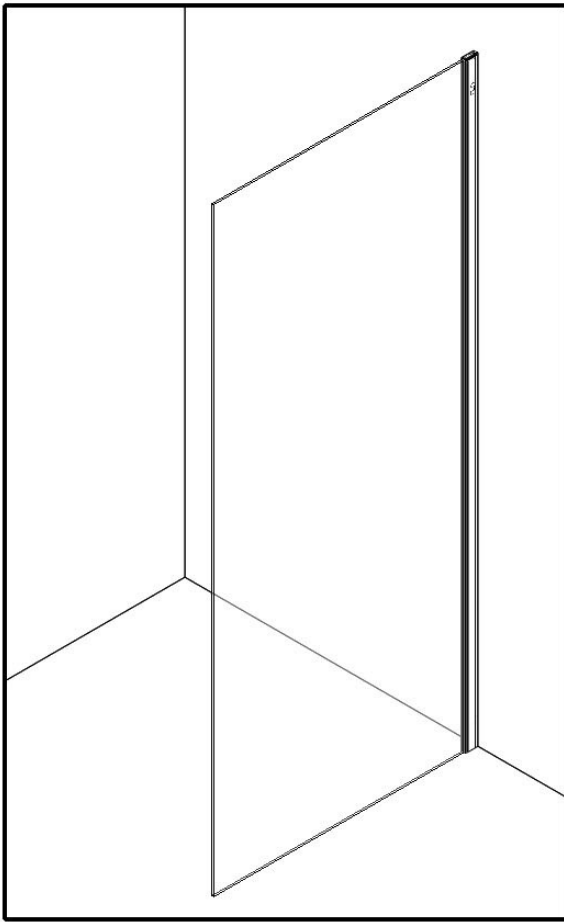

- F Ajuster puis verrouiller  
     ● <sup>GB</sup> Fit then block
- I Regolare e poi bloccare  
     ● <sup>NL</sup> Afstellen en slot
- D Ausrichten und sperren

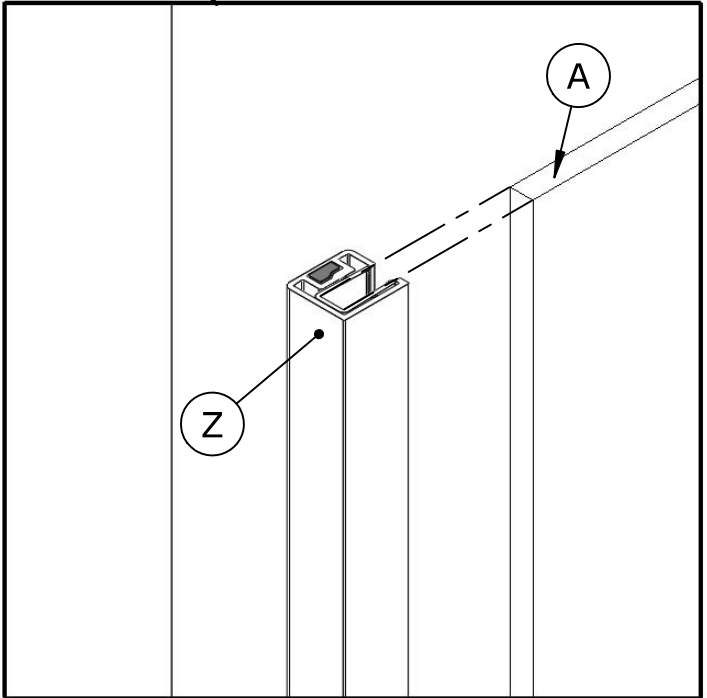
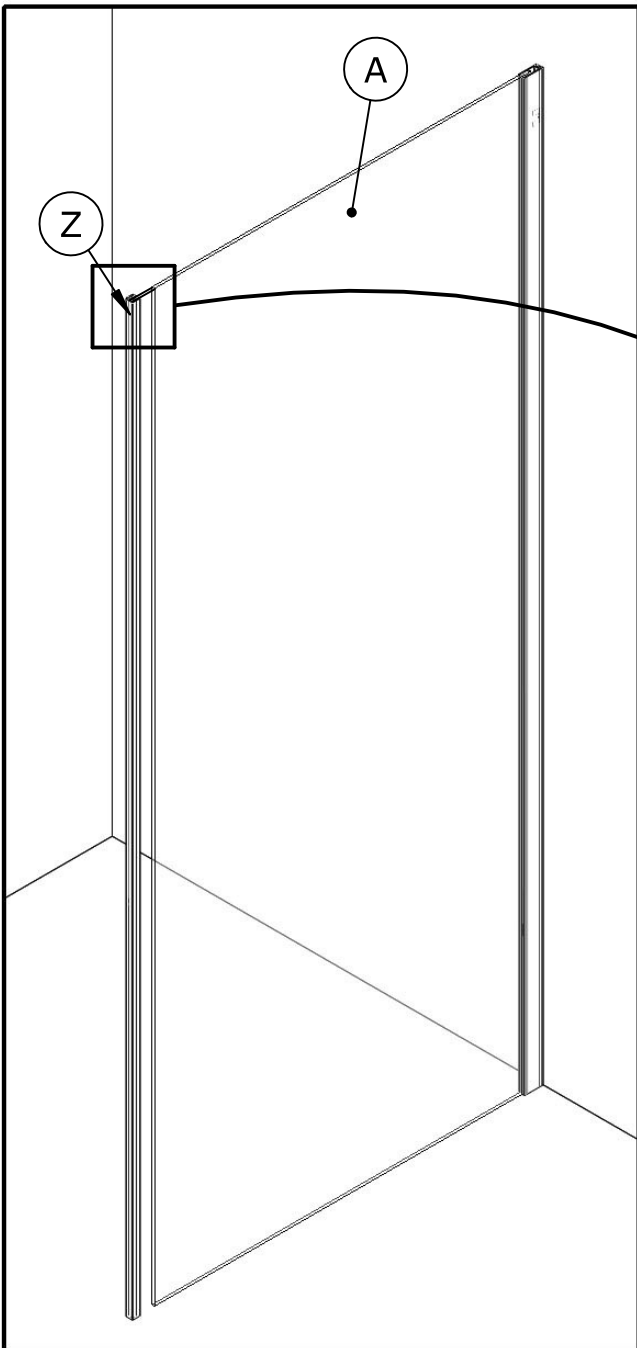

- F Intérieur ● GB Inside
- I Interno
- NL Binnenkant ● D Innen

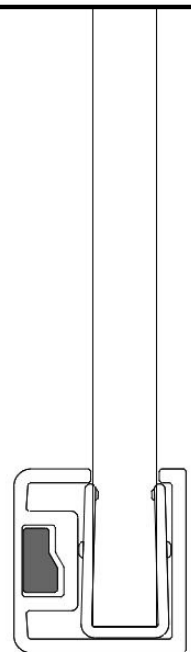

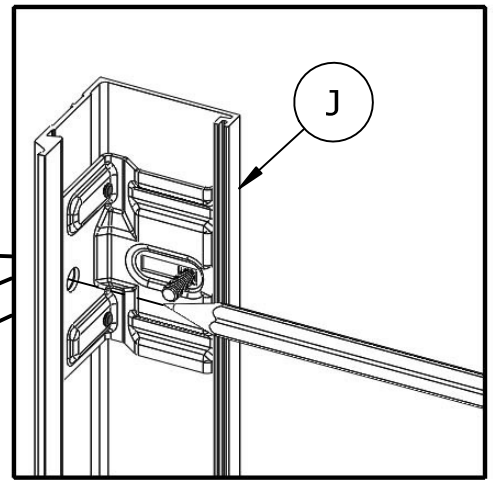
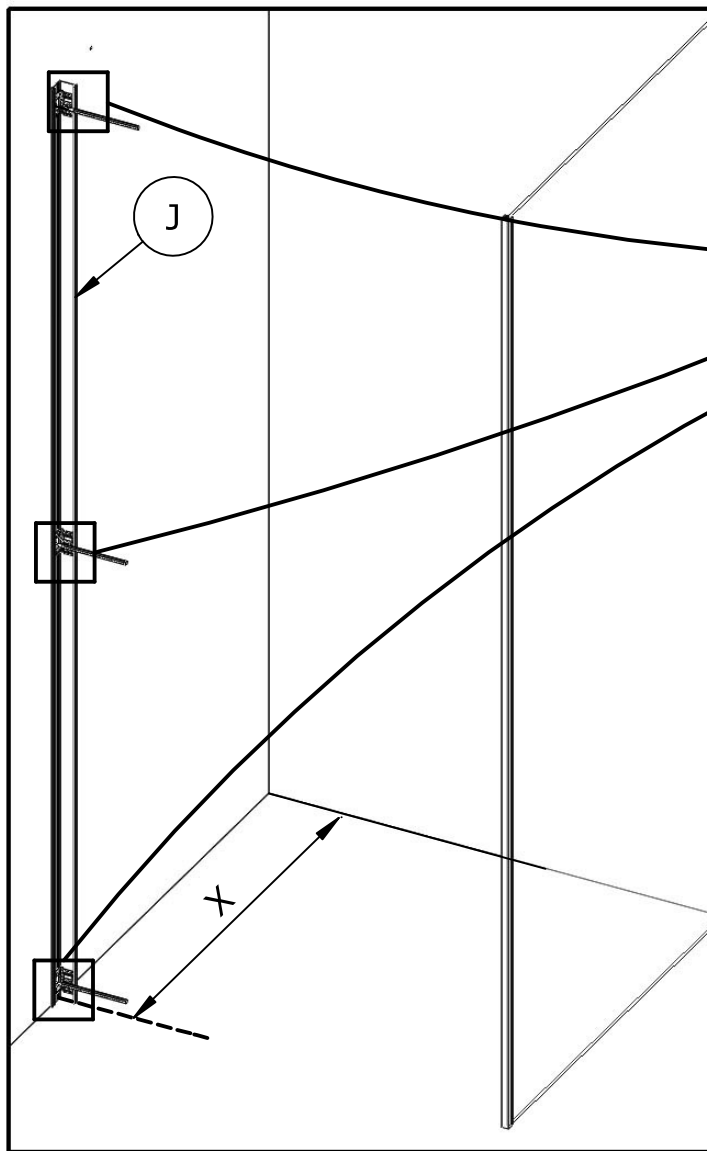

- F Si receveur ● GB If shower tray  
 ● I Se piatto ● NL Als douchebak  
 ● D Wenn Duschwanne

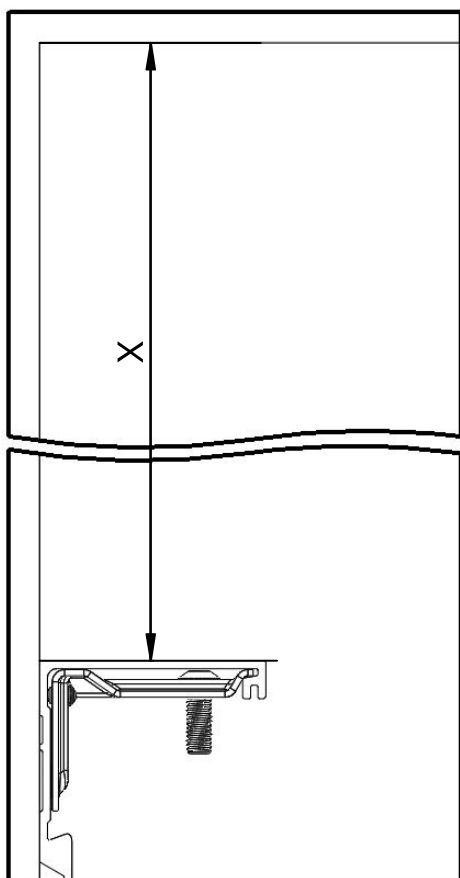
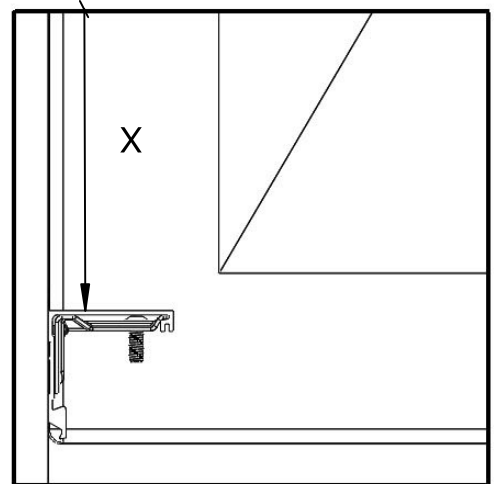

DIMENSIONS (cm)	X (mm)
70	630 - 645
75	660 - 675
80	730 - 745
85	760 - 775
90	830 - 845
95	860 - 875
100	930 - 945
110	1030 - 1045
120	1130 - 1145
130	1230 - 1245
140	1330 - 1345

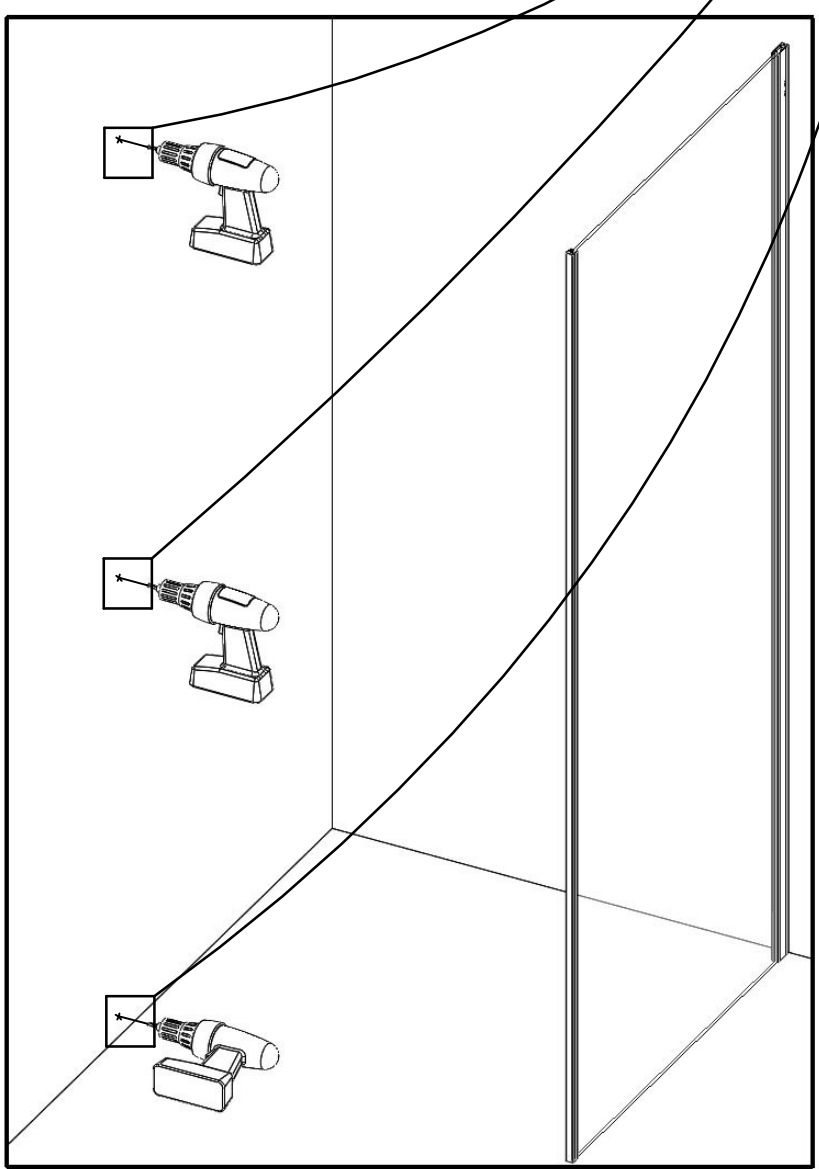
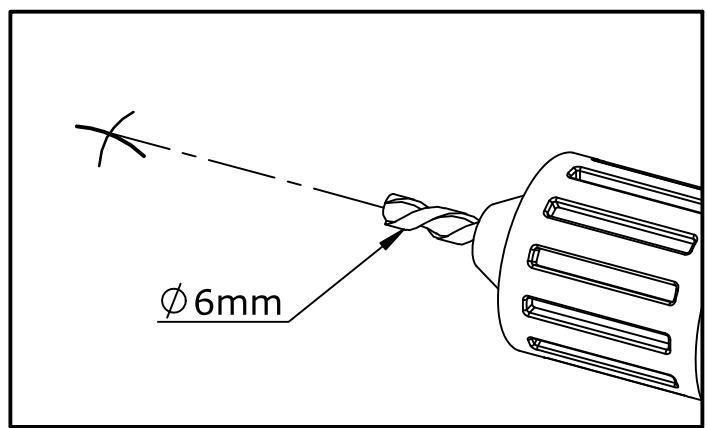

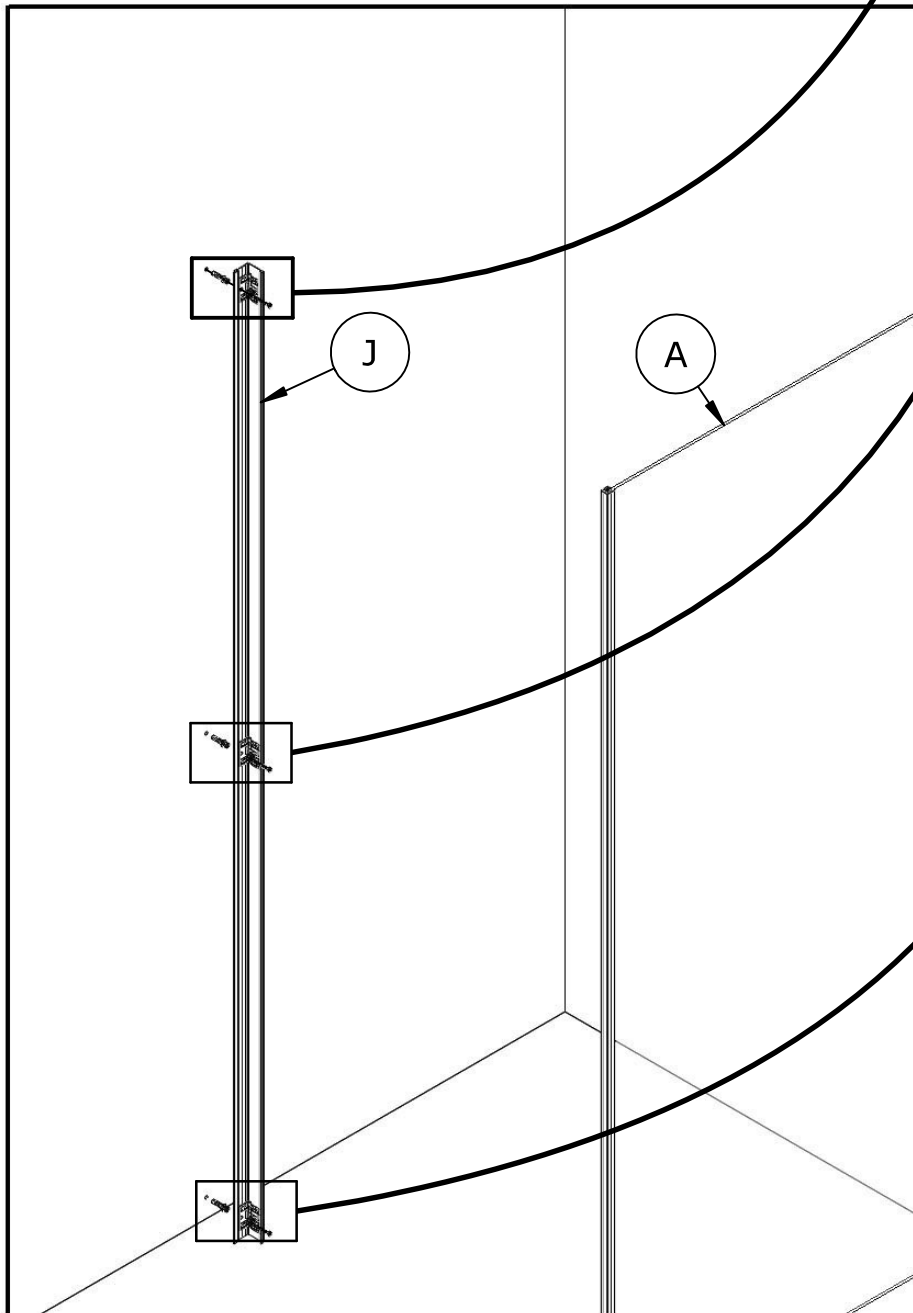
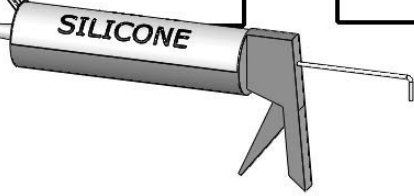
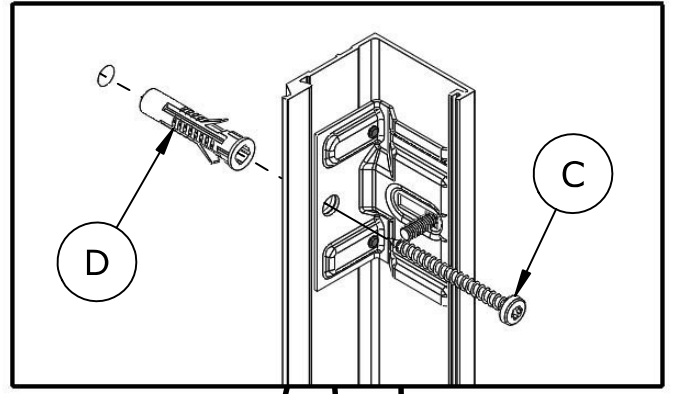
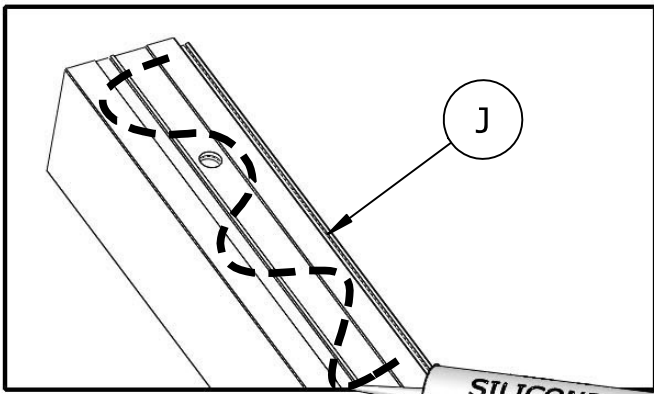

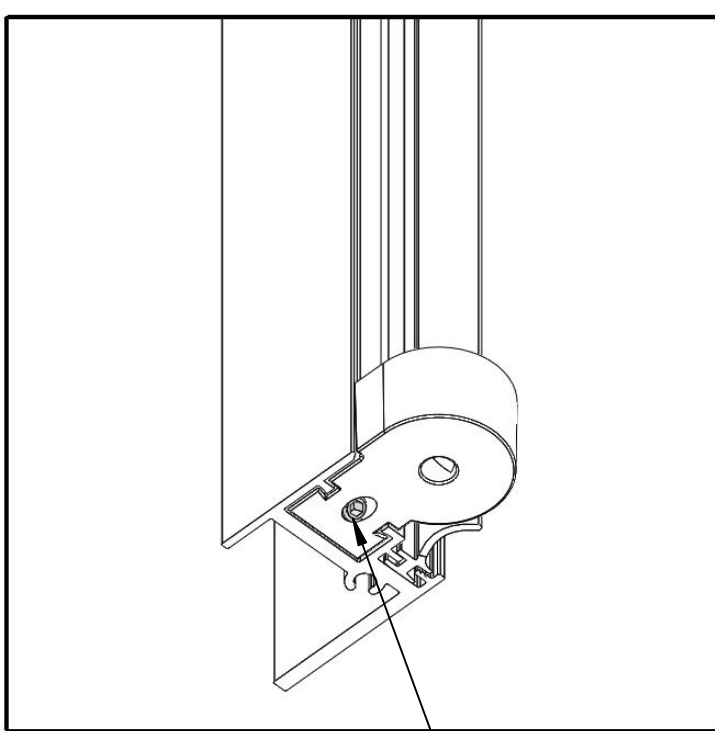
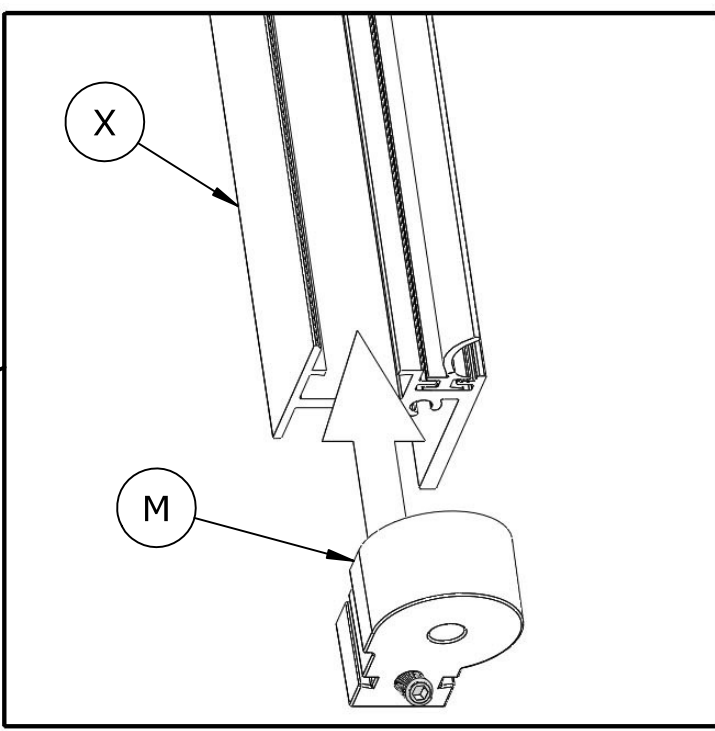
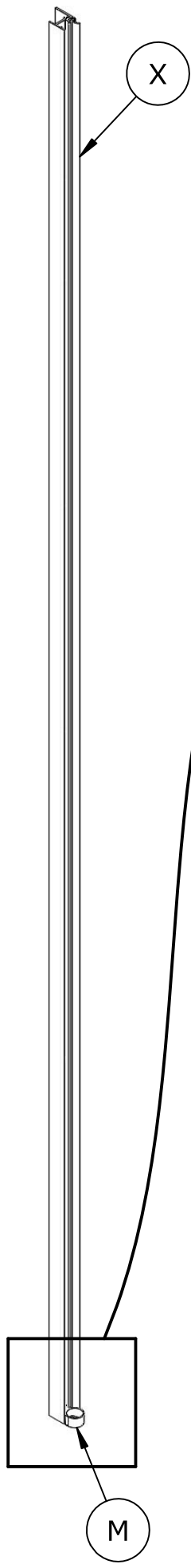

● Serrer fort ● Squeeze tightly  
● Serrare bene  
● Draai stevig vast ● Fest anziehen

- F Adjuster puis serrer ● GB Fit then tighten 
- I Regolare e poi serrare
- NL Stel af en draai vast ● D Anpassen dann anziehen

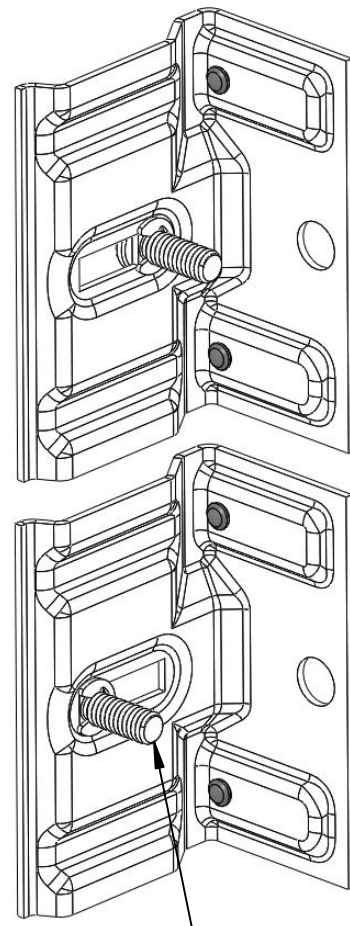

- F Si nécessaire, desserrer, régler puis resserrer
- GB If necessary, loosen, adjust and retighten
- I Se necessario, allentare, regolare e stringere
- NL Draai los, indien nodig, stel af en draai vervolgens weer vast
- D Falls erforderlich, lösen, einstellen und wieder festziehen

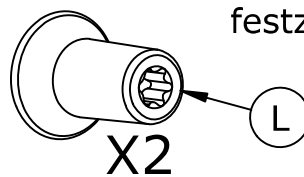

X2

L

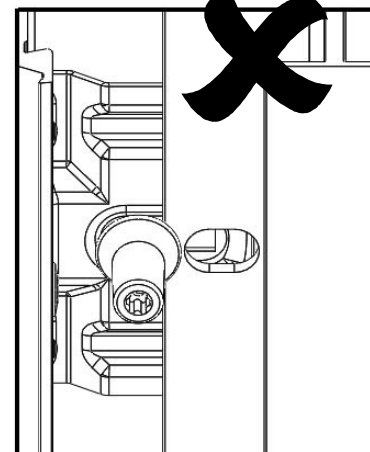
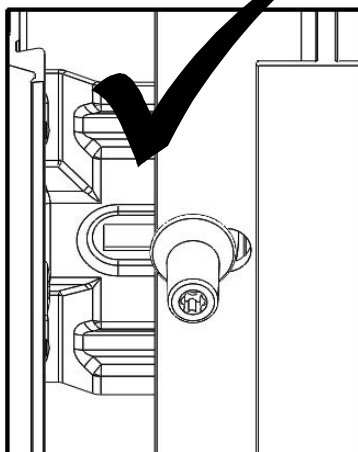
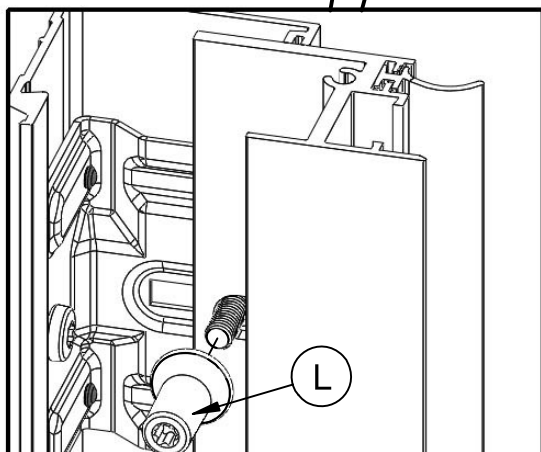

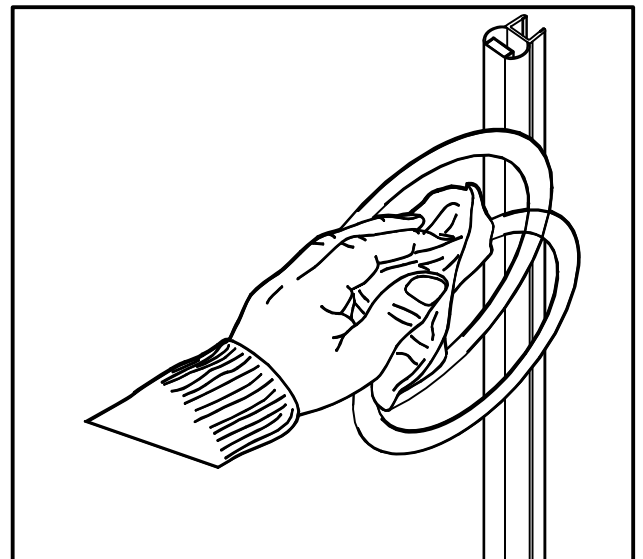
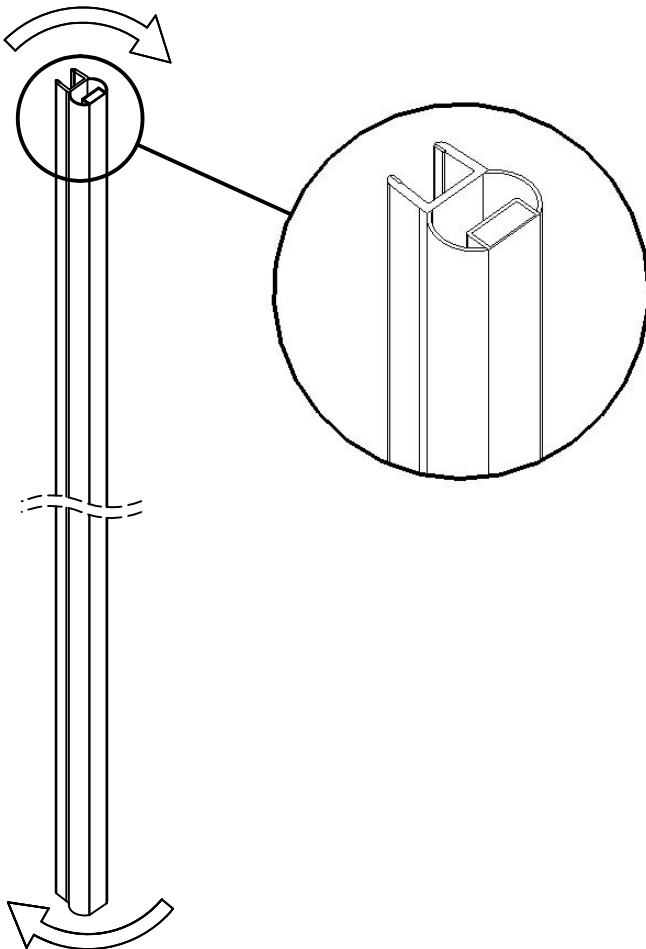
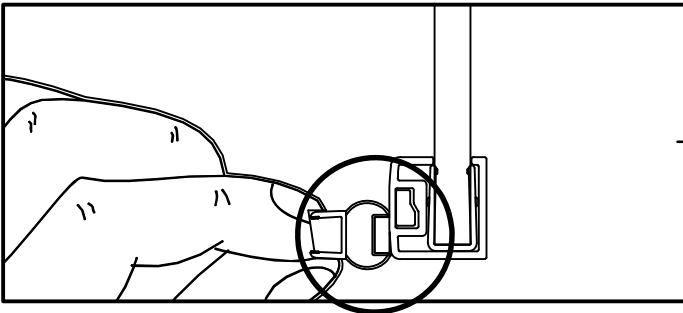
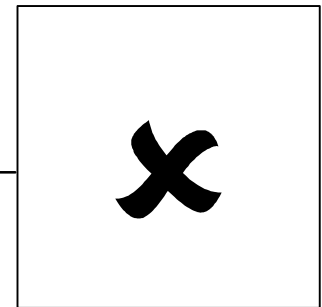
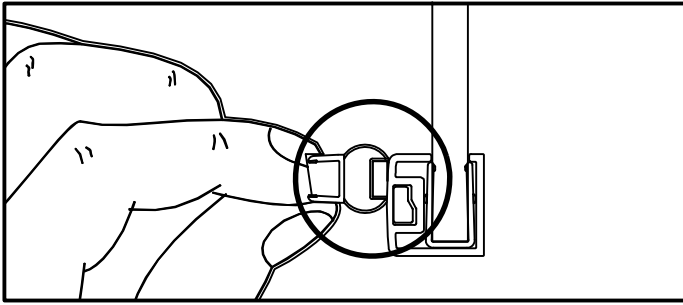
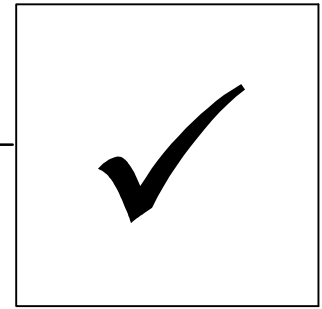
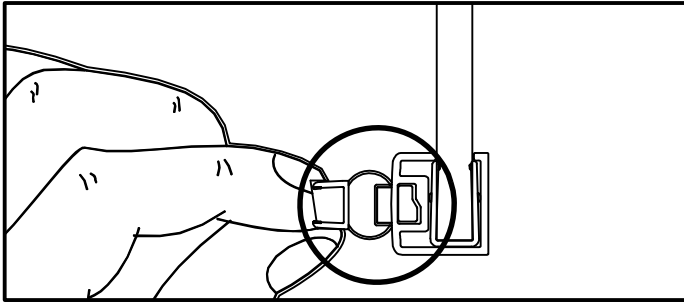



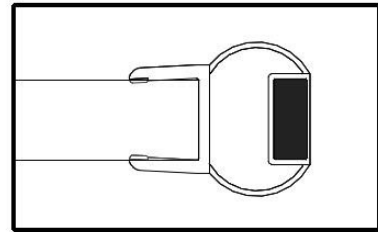
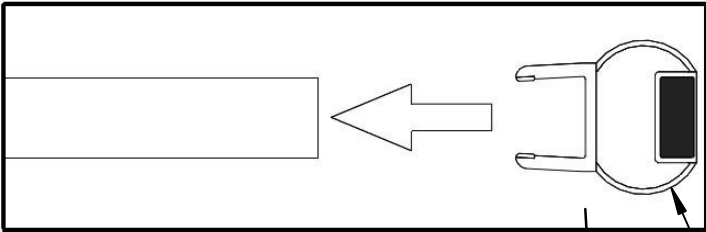

P

P

O

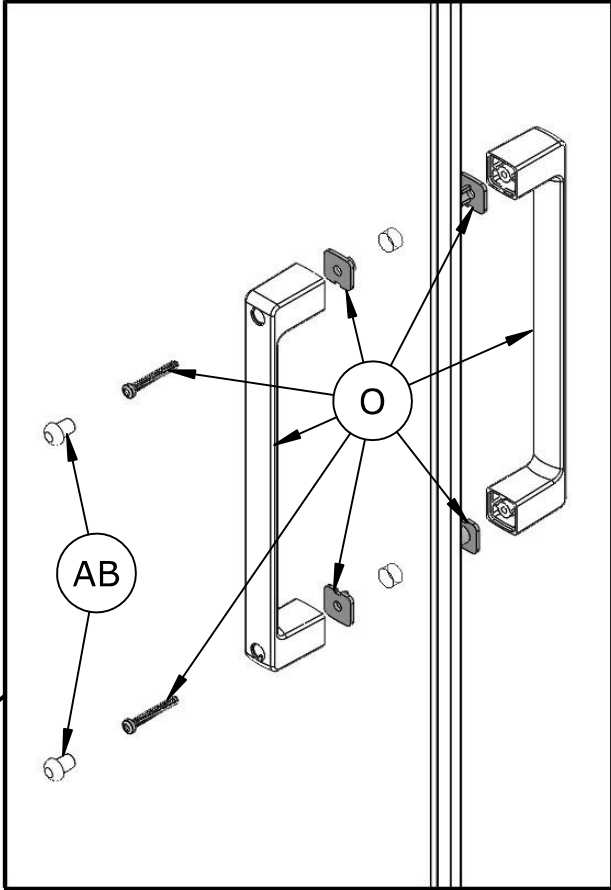

AB

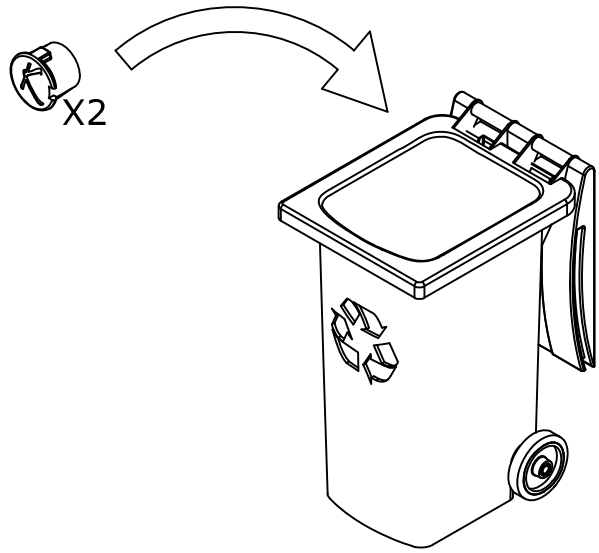

X2

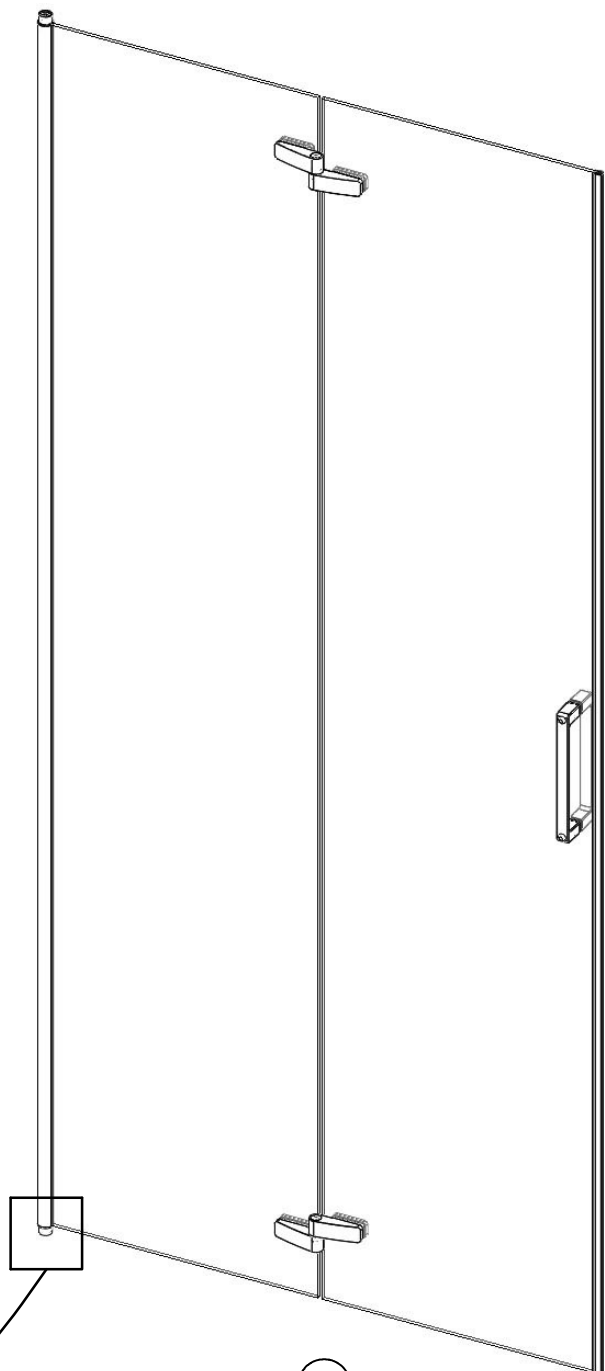
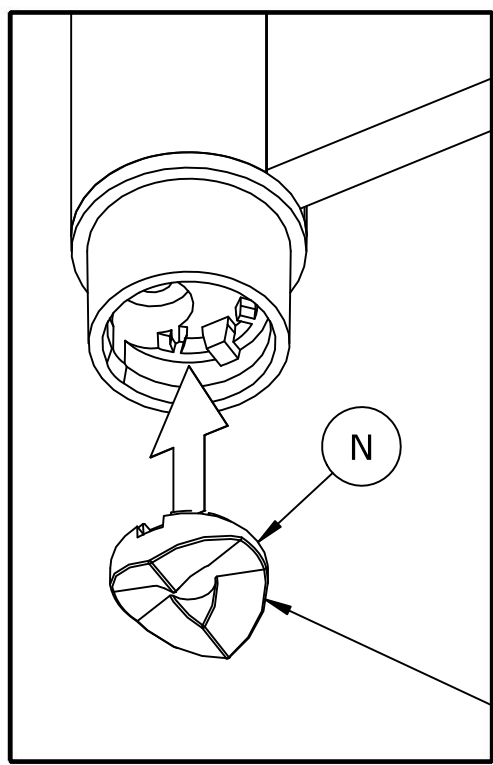
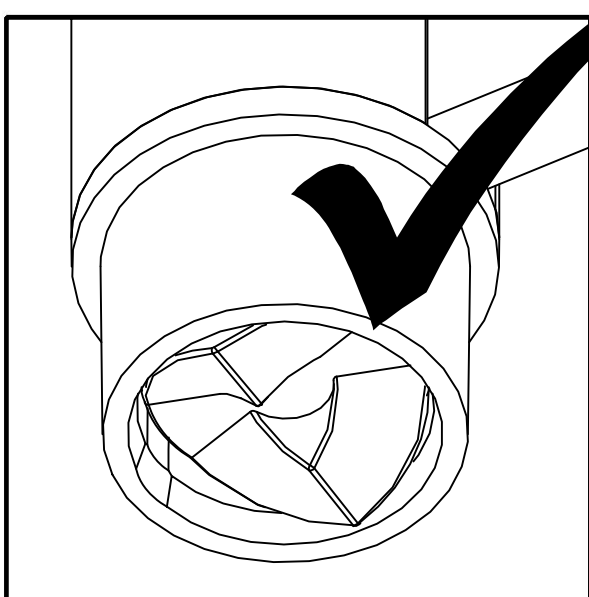
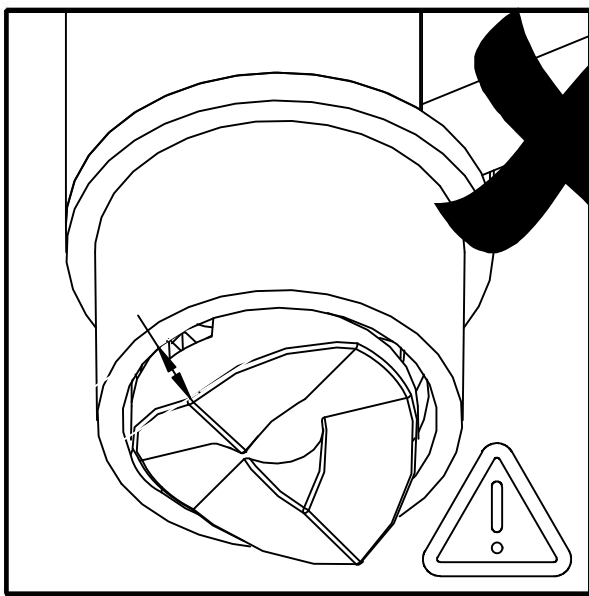

- F Mettre en partie basse
- GB Put in the lower part
- I Mettere nella parte inferiore
- NL Plaats in het onderste deel
- D Setzen Sie in den unteren Teil.

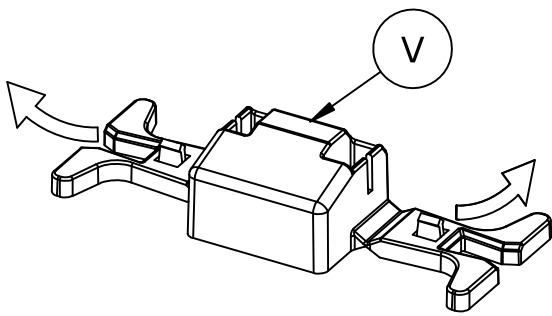

X2

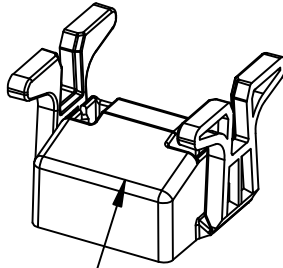

- F Extérieur douche
- GB outside shower
- I Esterno doccia
- NL Buitenkant van de douche
- D Außenansicht der Kabine

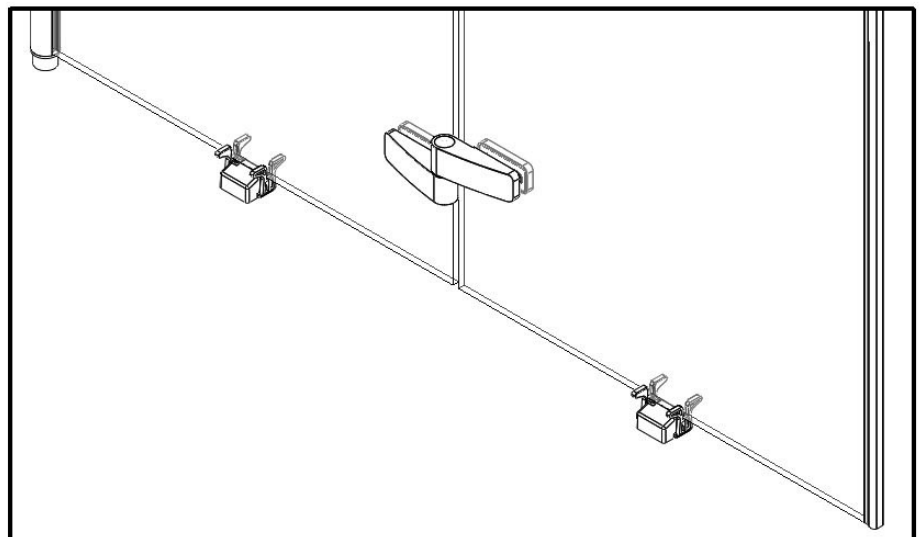
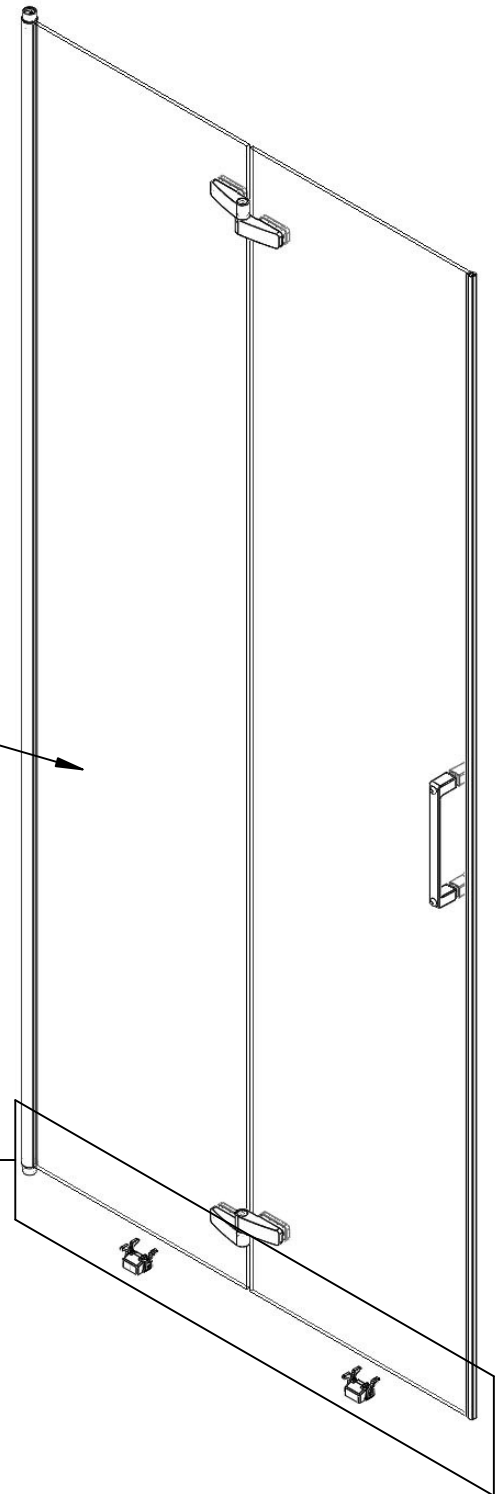
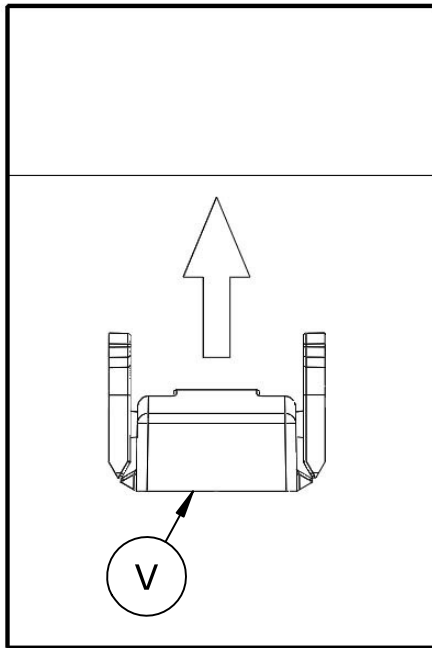

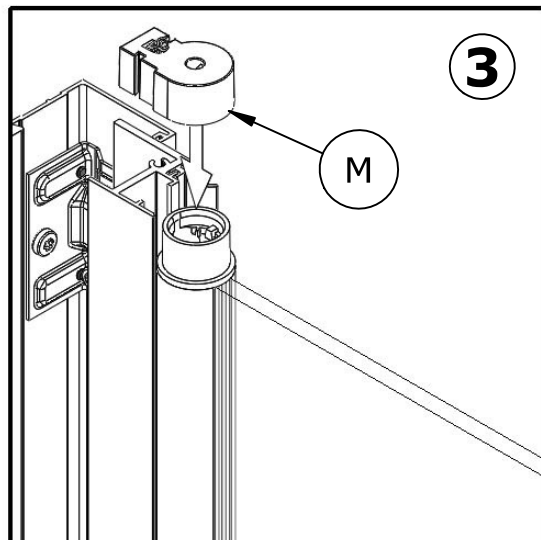
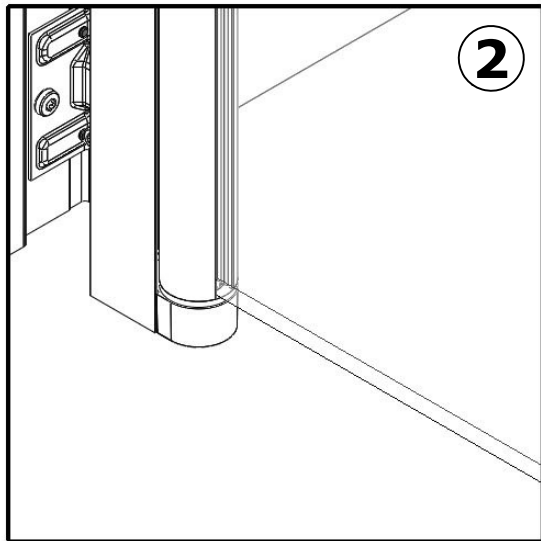
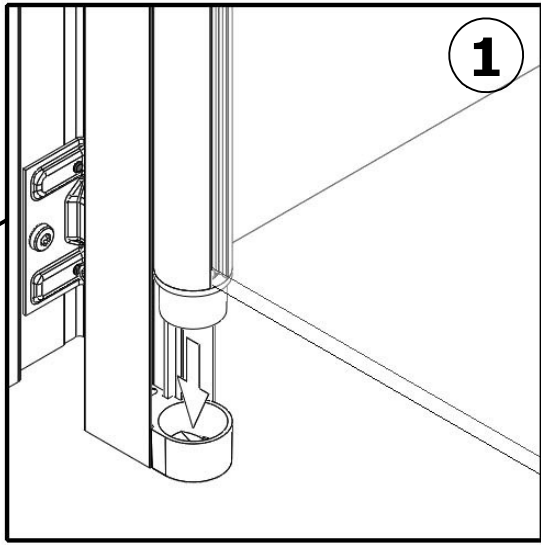
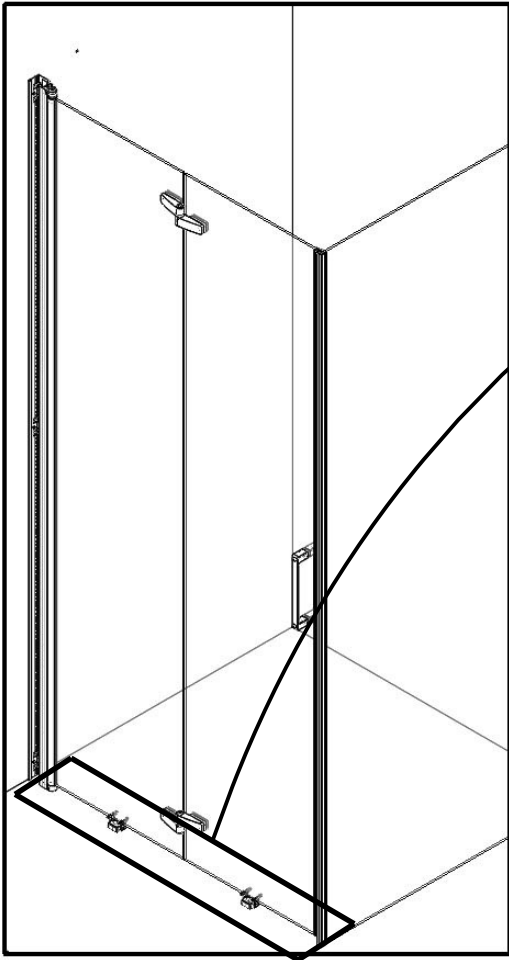

- F Serrer fort
- GB Squeeze tighten
- I Serrare bene
- NL Draai stevig vast
- D Fest anziehen

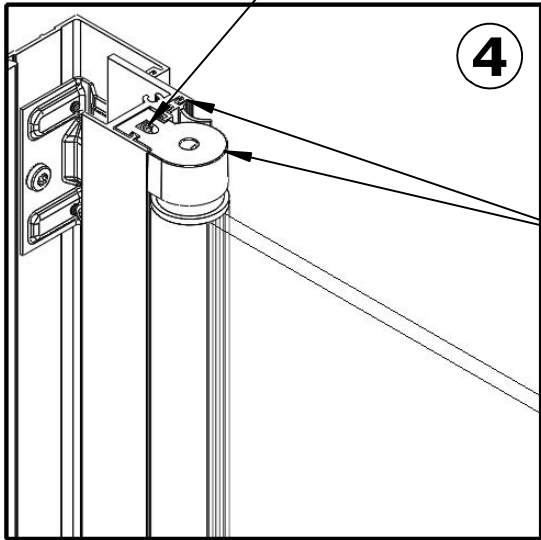

- F Affleurant
- GB Align
- I A filo
- NL Zijkanten niet laten uitsteken
- D Bündig auszurichtende oberseiten

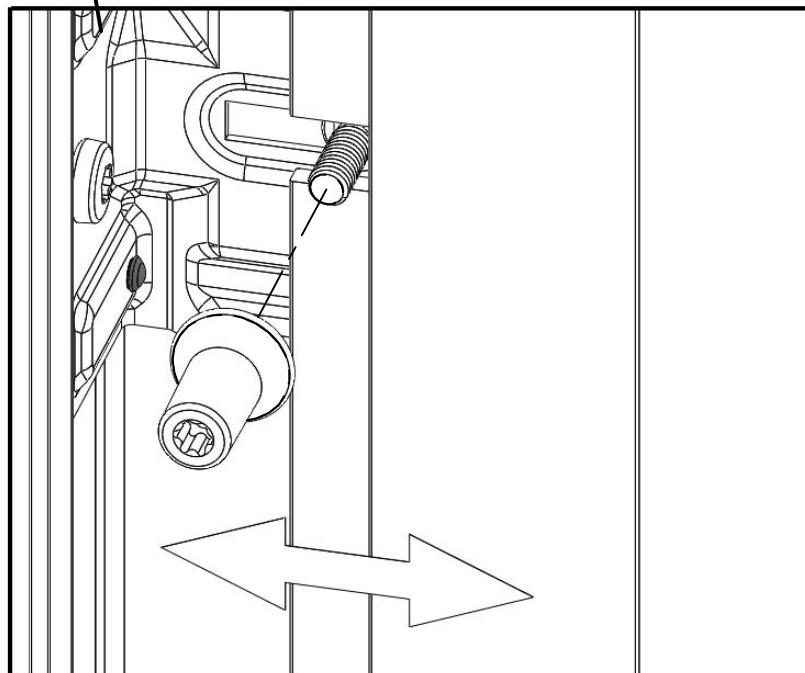
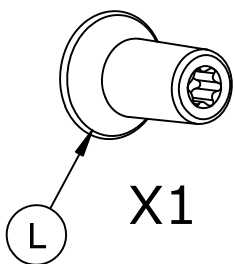
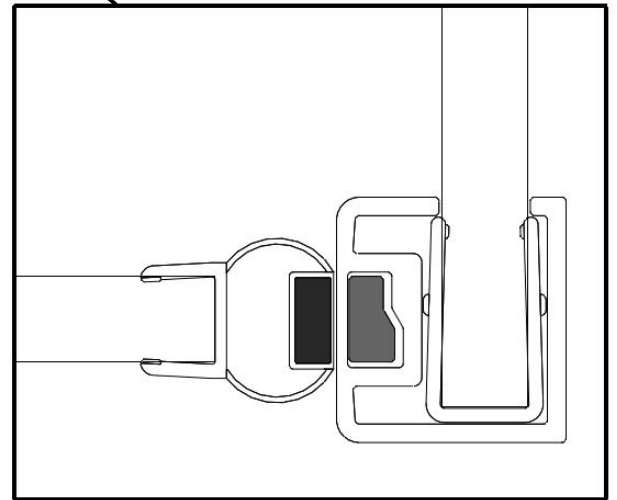
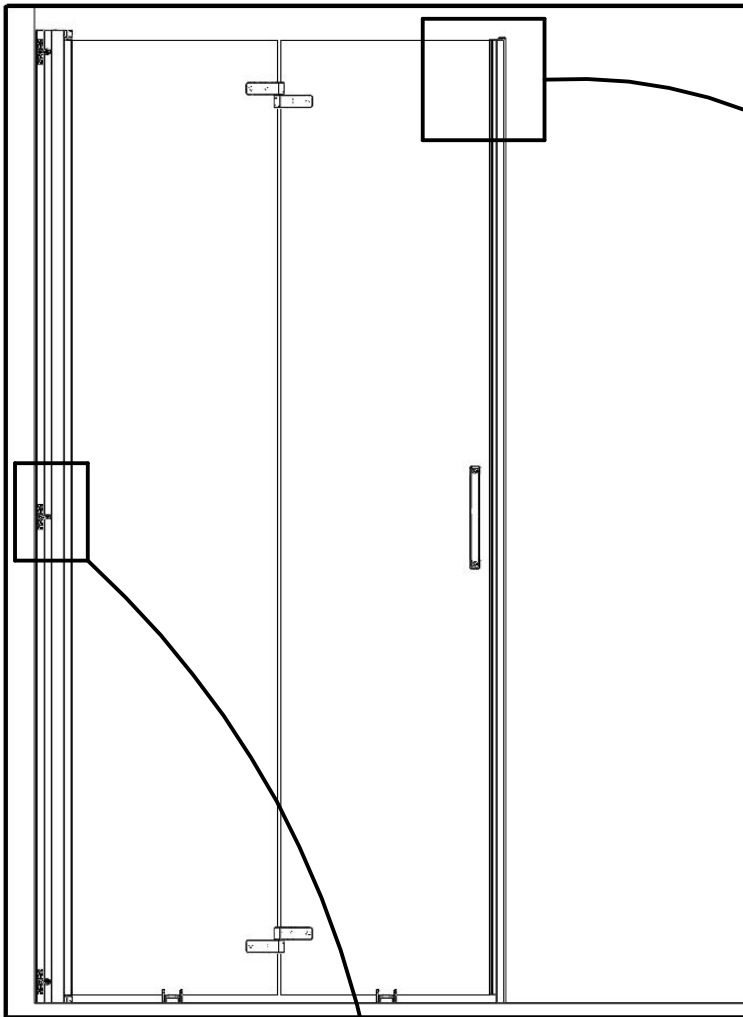

- Si nécessaire, desserrer, régler puis resserrer
- If necessary, loosen, adjust and retighten
- Se necesario, allentare, regolare e stringere
- NL Draai los, indien nodig, stel af en draai vervolgens weer vast
- Falls erforderlich, lösen, einstellen und wieder festziehen

● F Retirer ● GB Remove ● I Togliere  
● NL Verwijderen ● D Entfernen

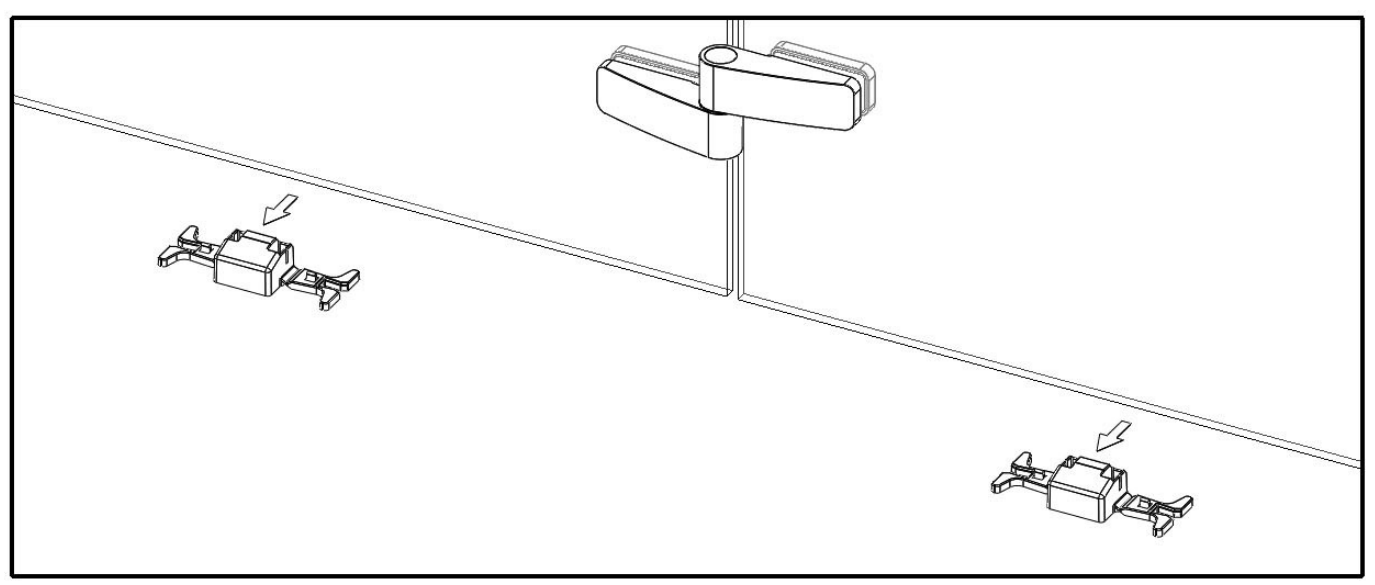
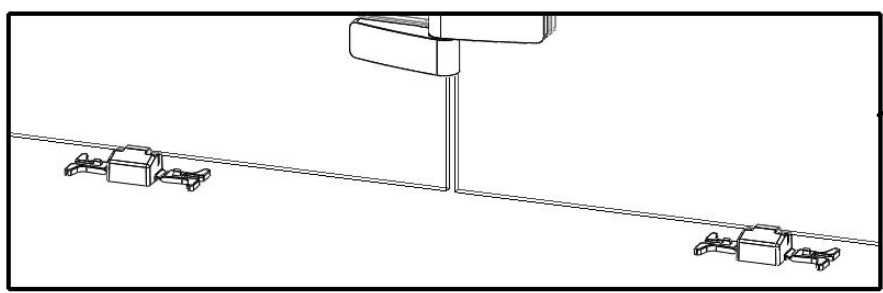
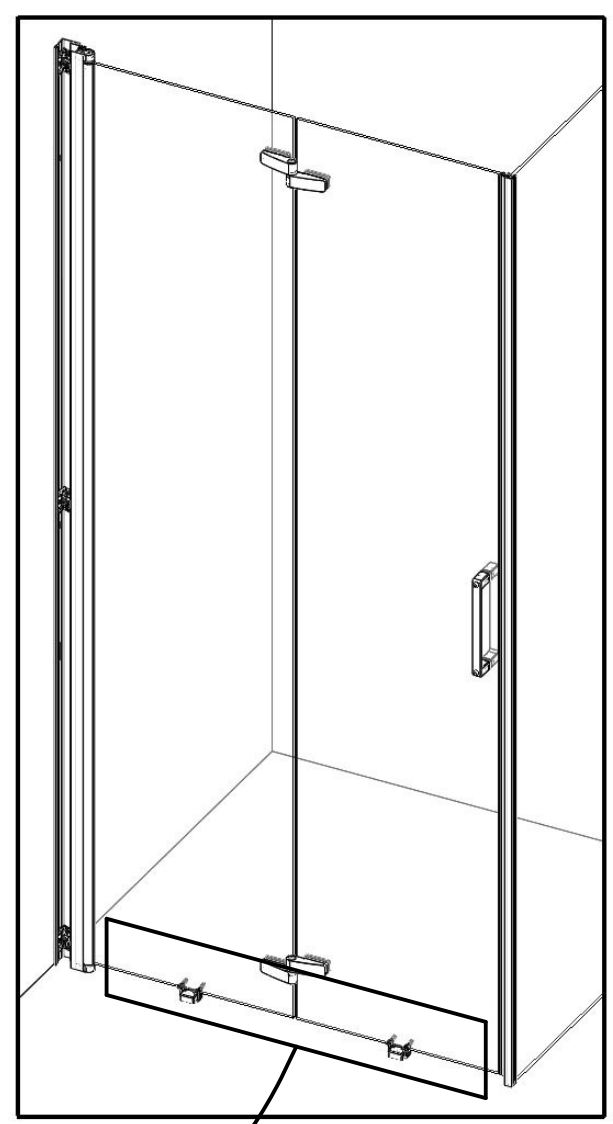
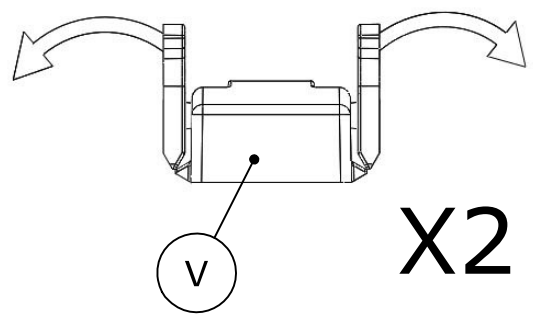

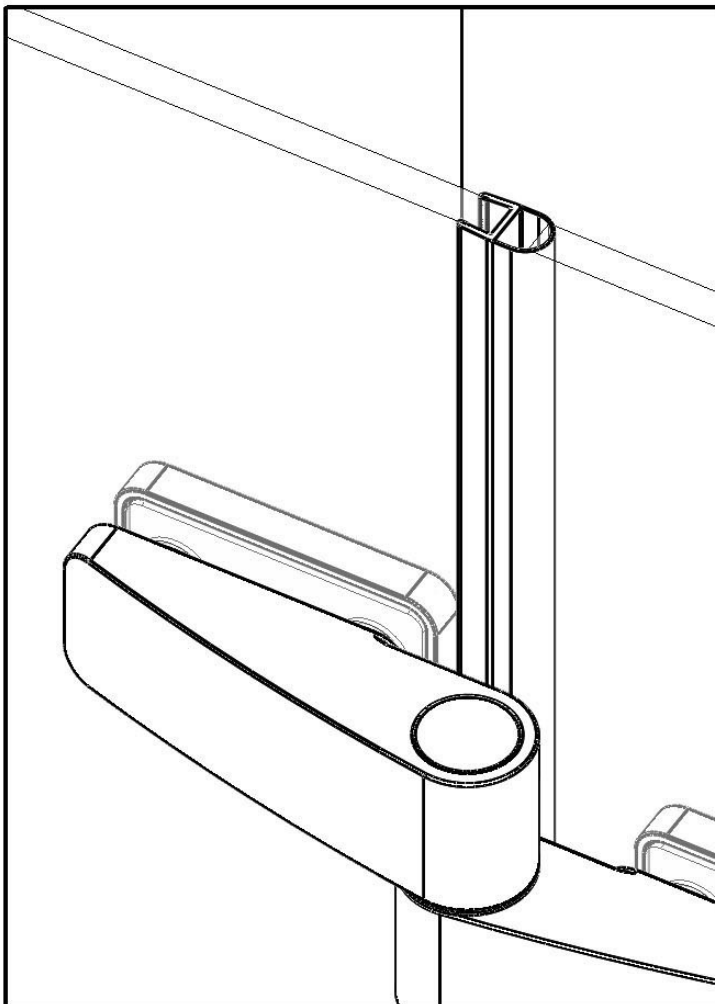
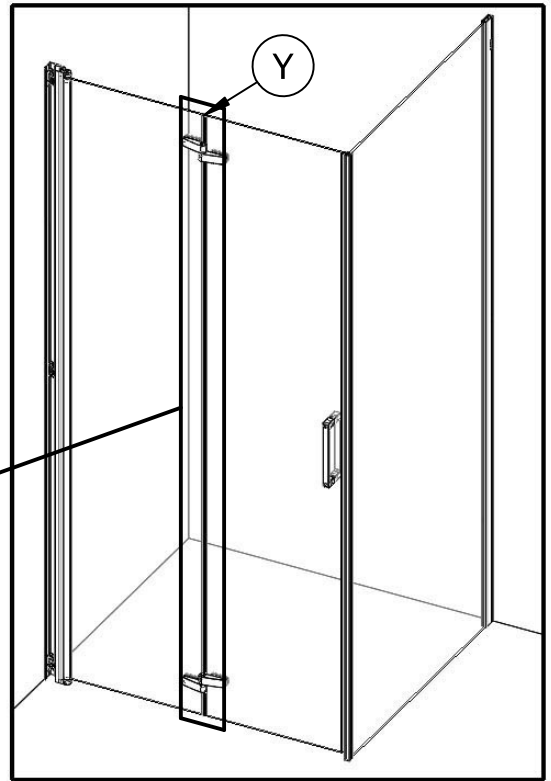
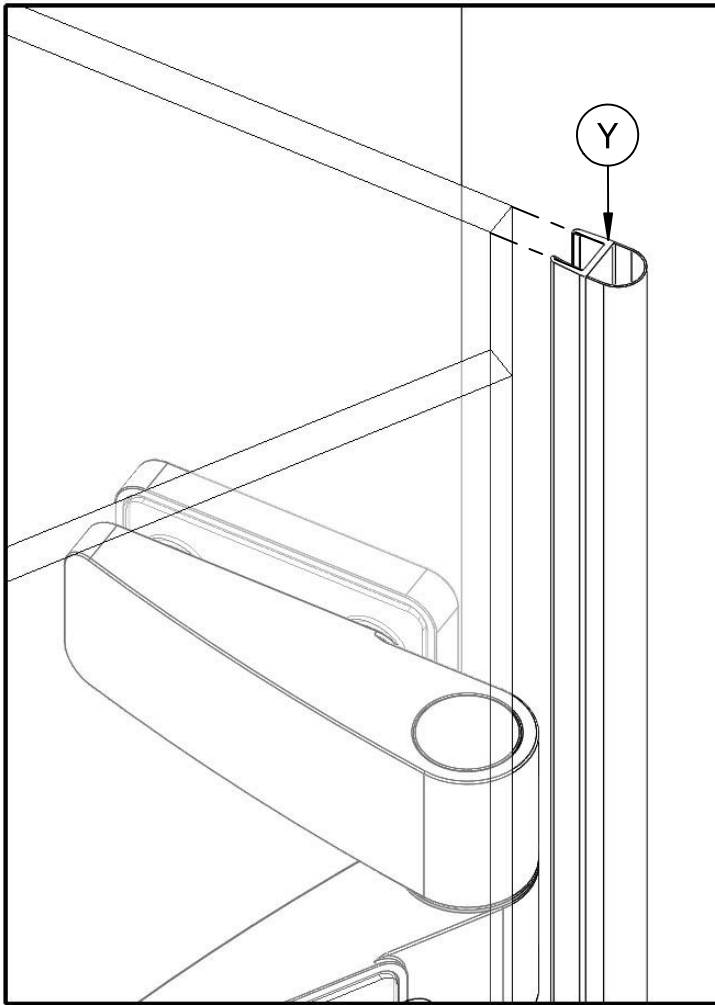

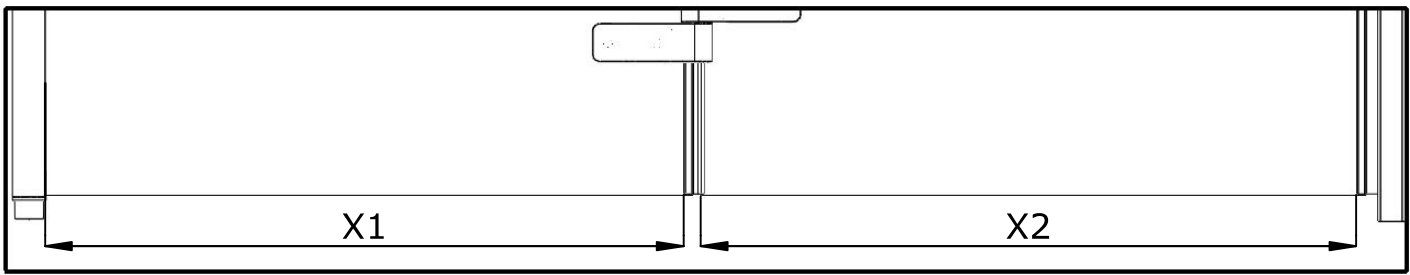

- Intérieur douche
- Inside shower
- Doccia interni
- Binnenkant van de douche
- Innenraum der Kabine

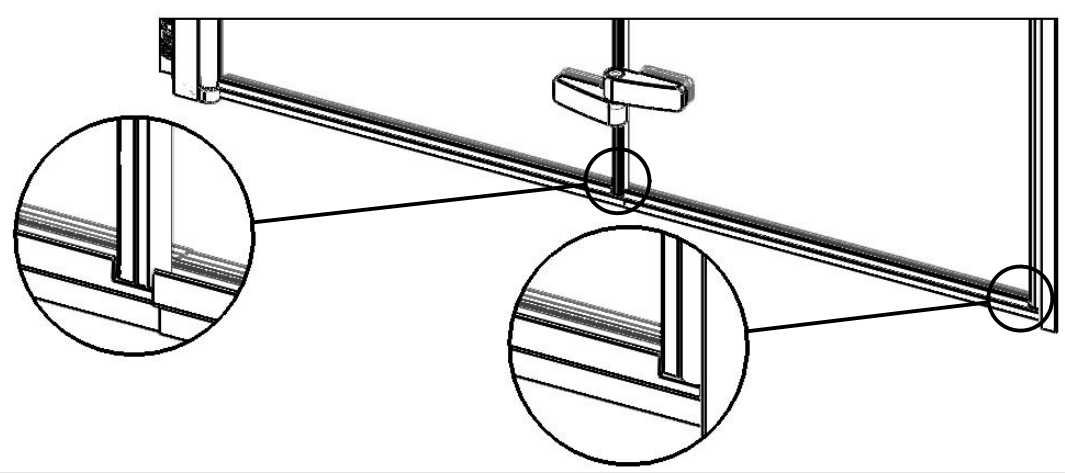
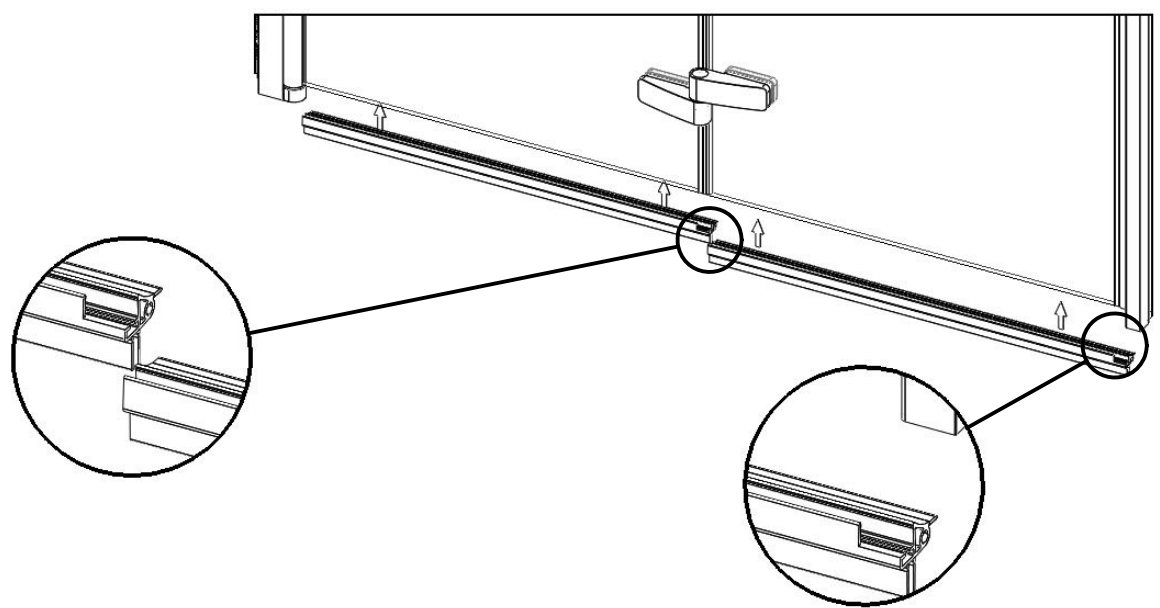
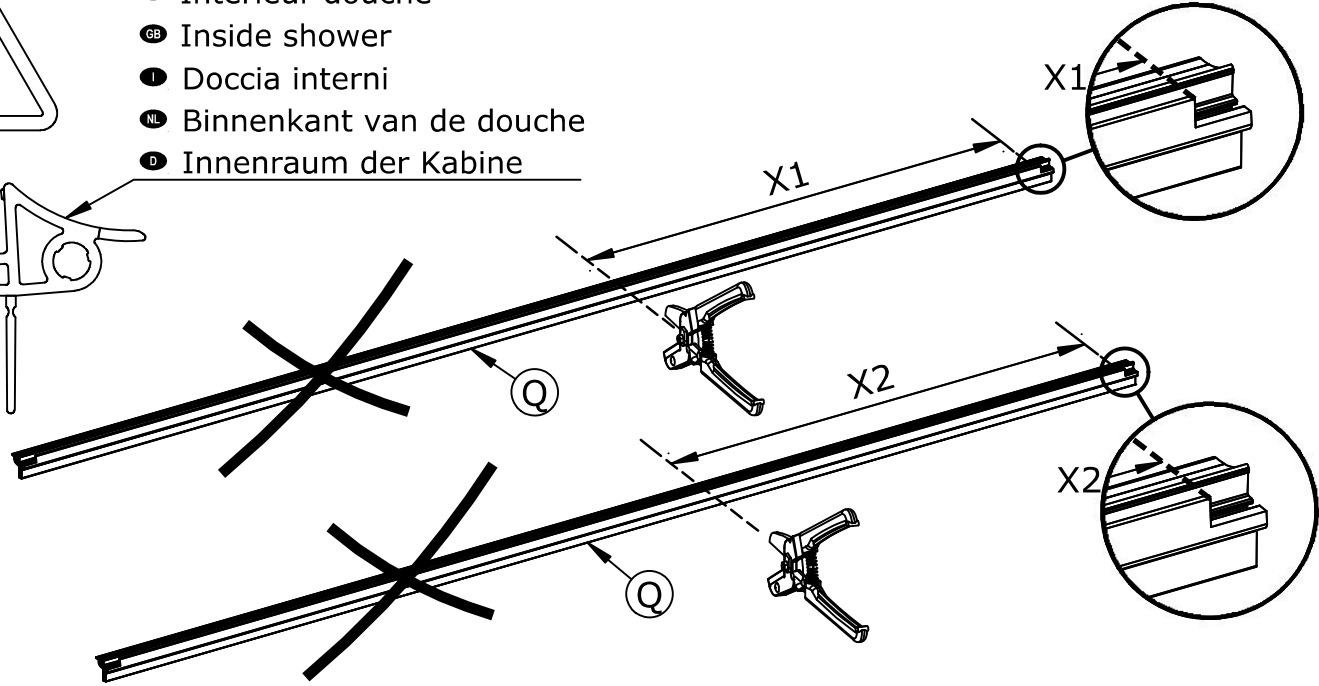
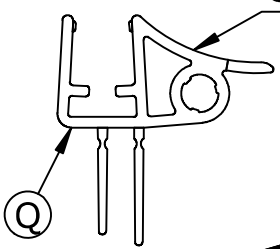



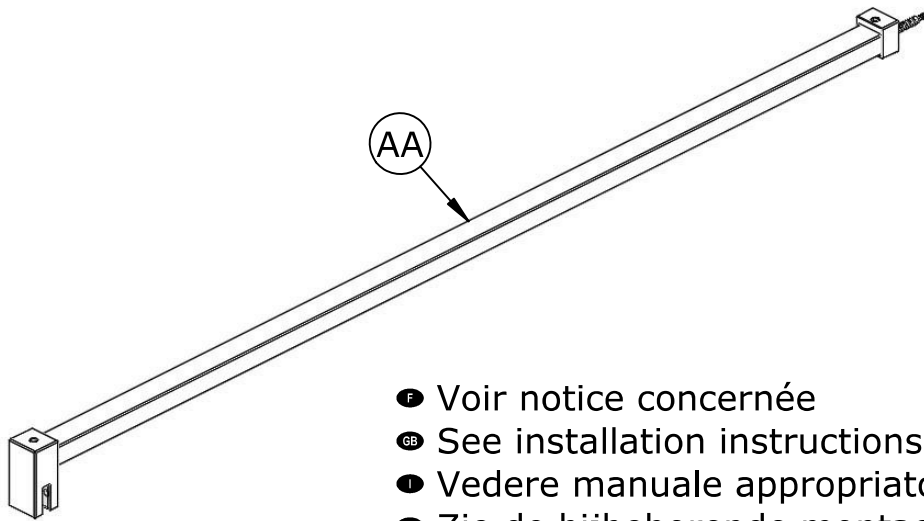

- Voir notice concernée
- See installation instructions required
- Vedere manuale appropriato
- Zie de bijbehorende montagehandleiding
- Siehe betreffende Anleitung

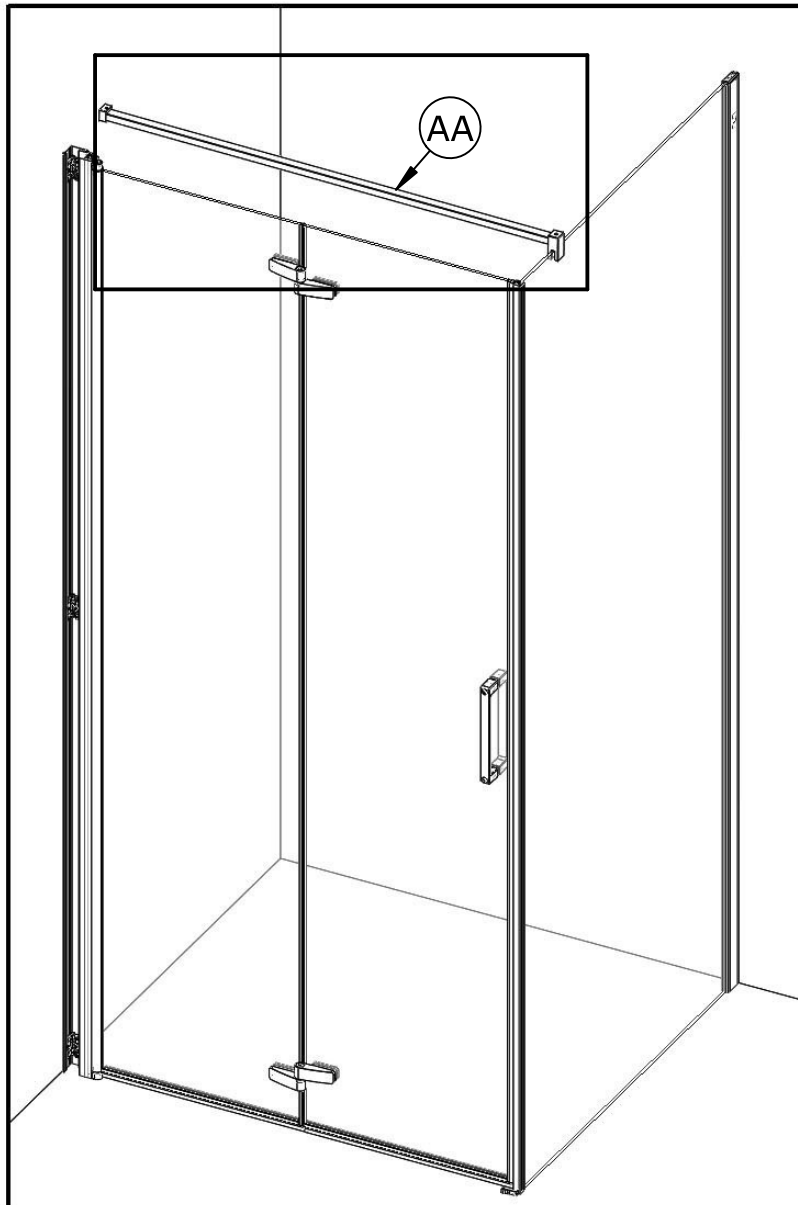

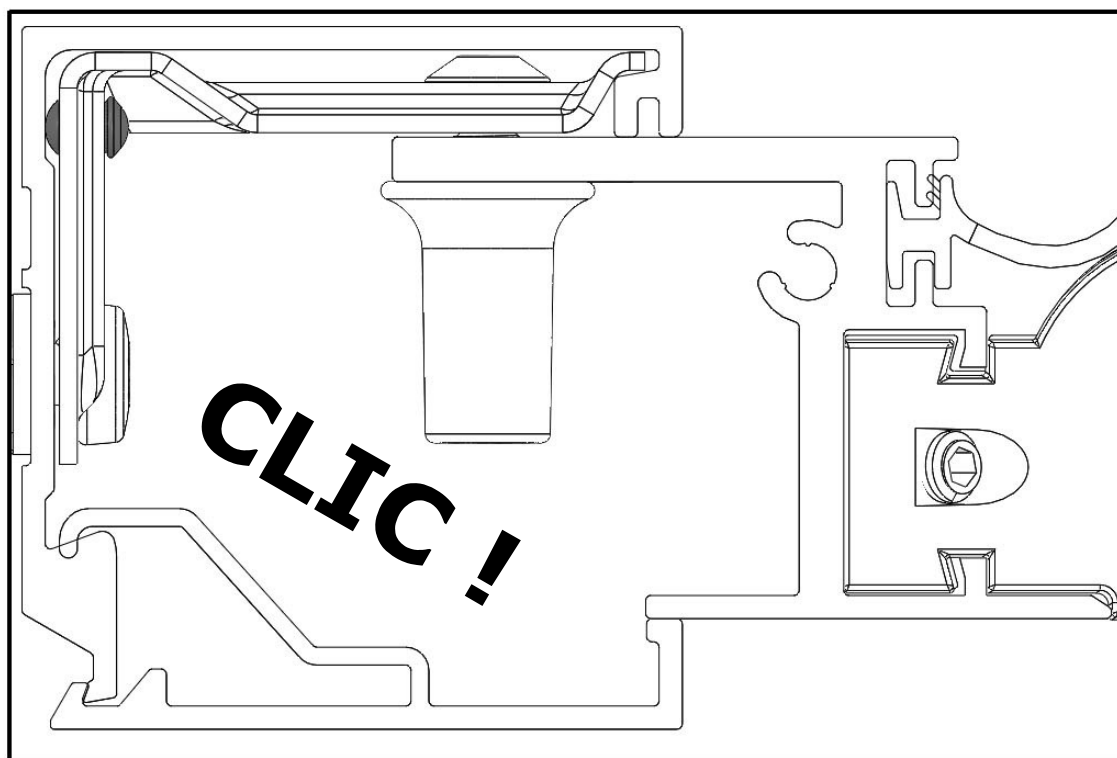
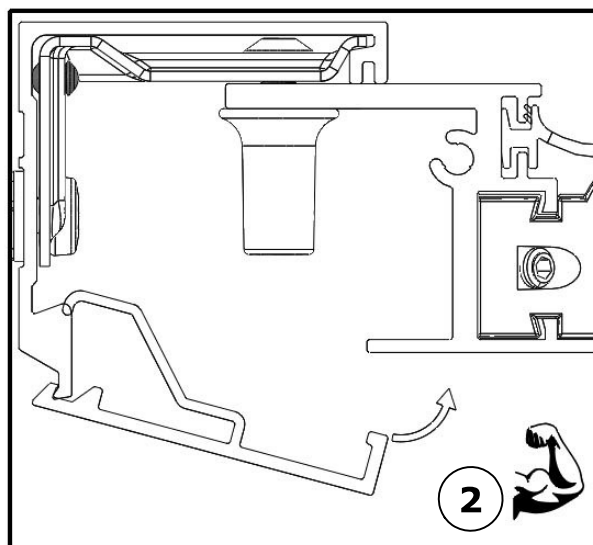
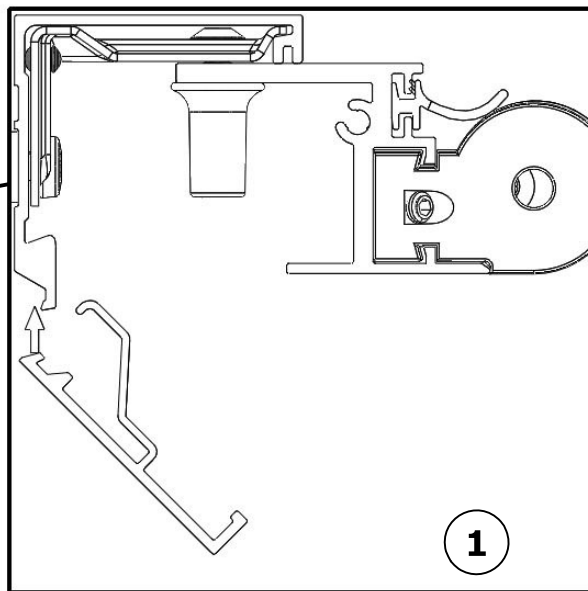
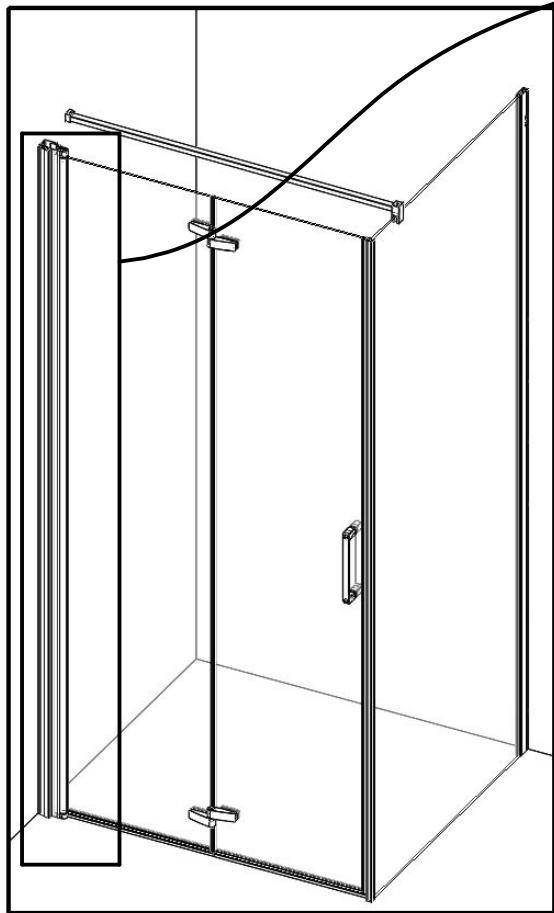

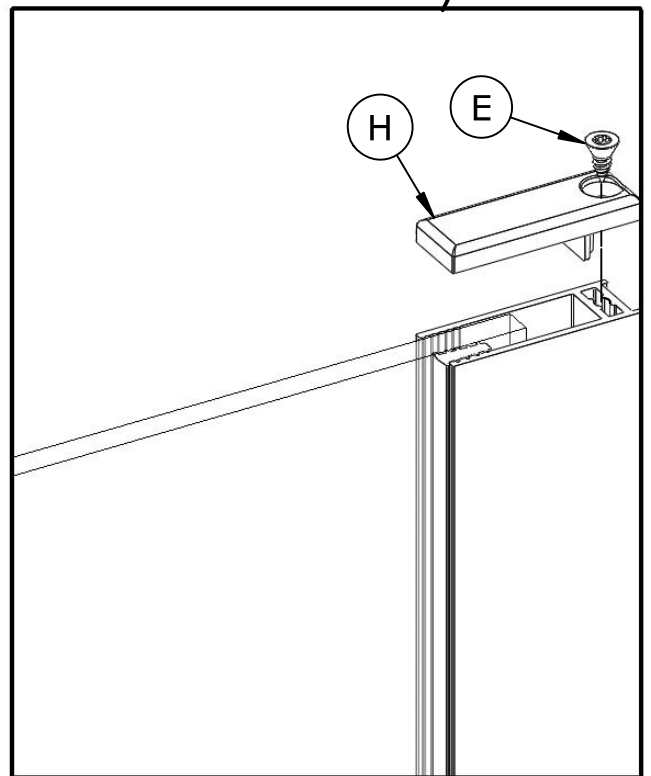
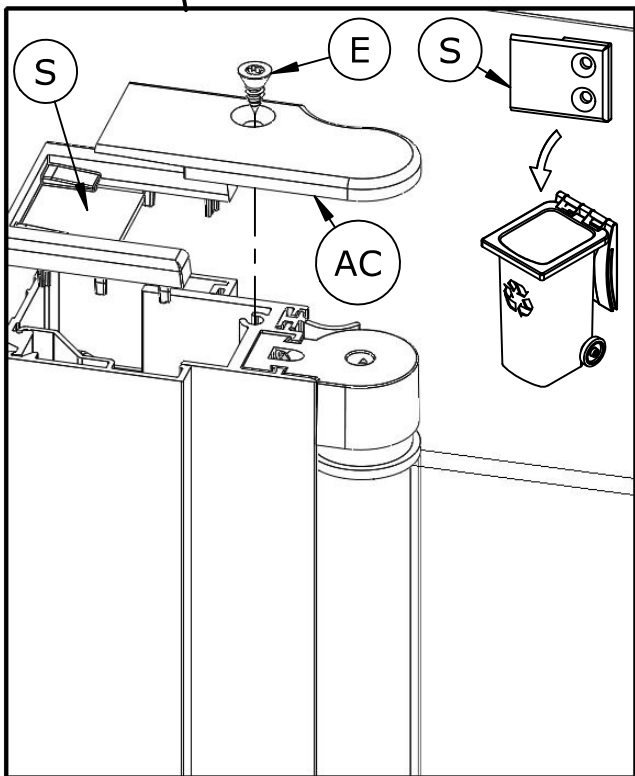
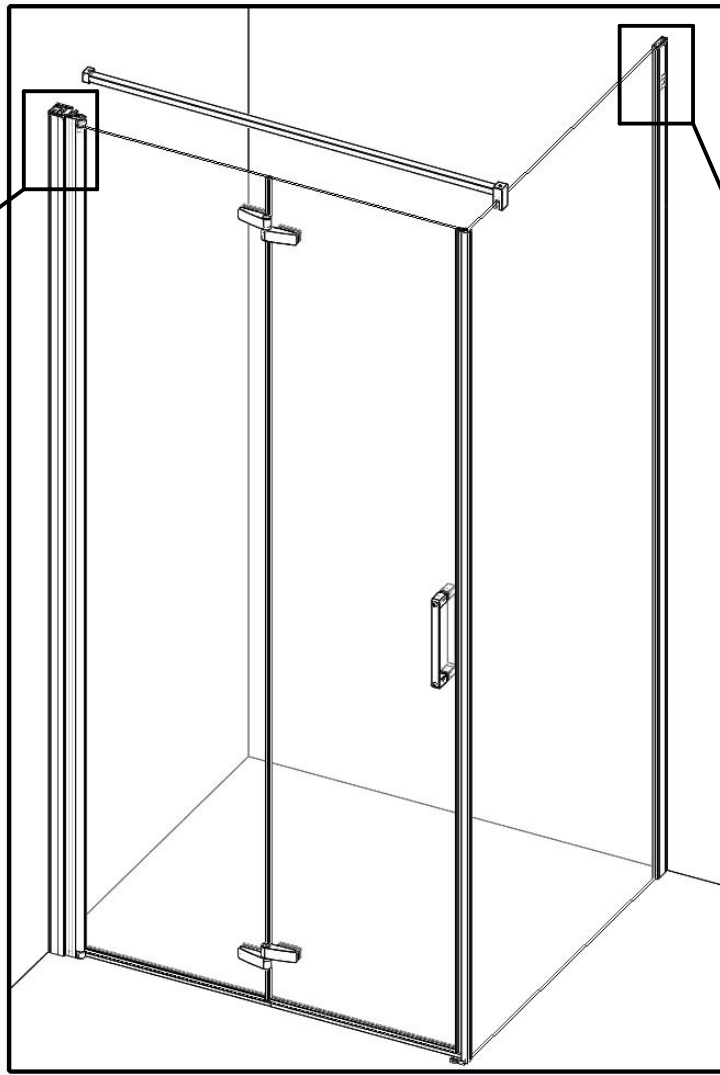

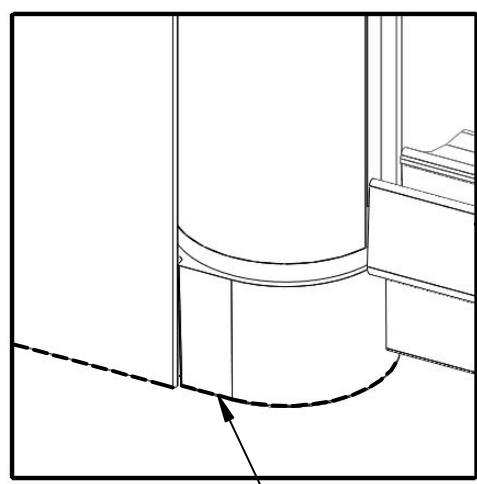
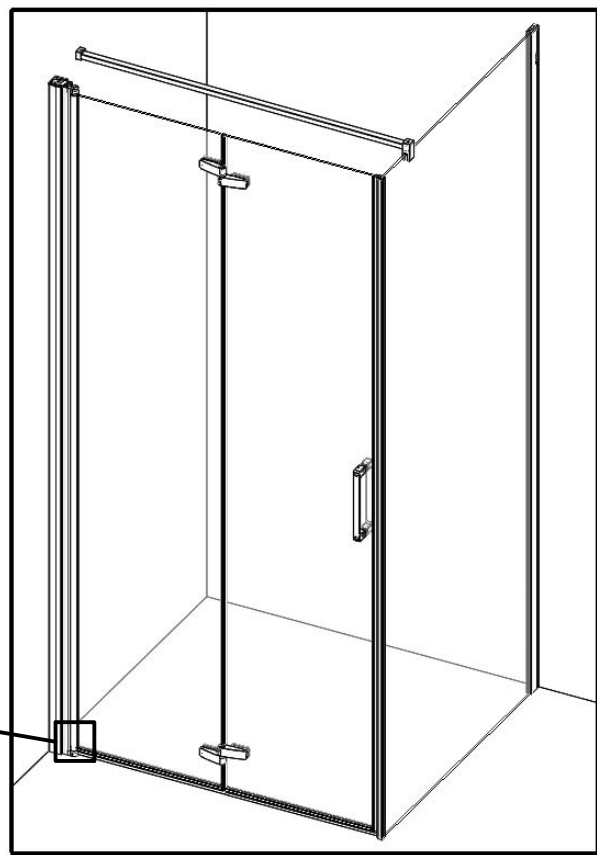
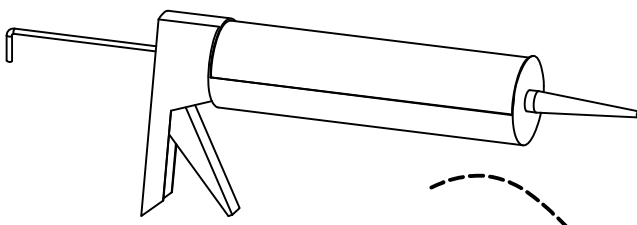

● F Extérieur ● GB Outside  
● I Esterno  
● NL Buitenkant ● D Außen

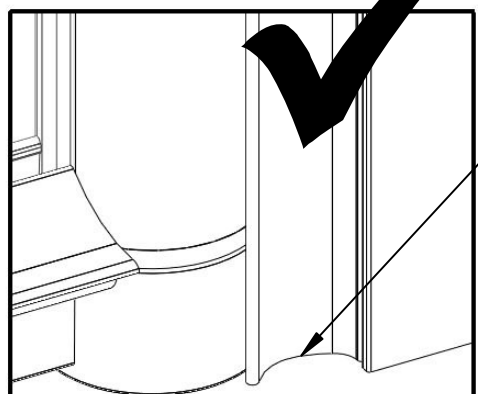
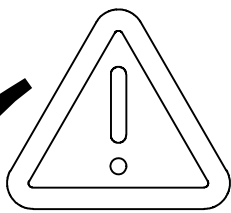

● F Intérieur ● GB Inside  
● I Interno  
● NL Binnenkant ● D Innen

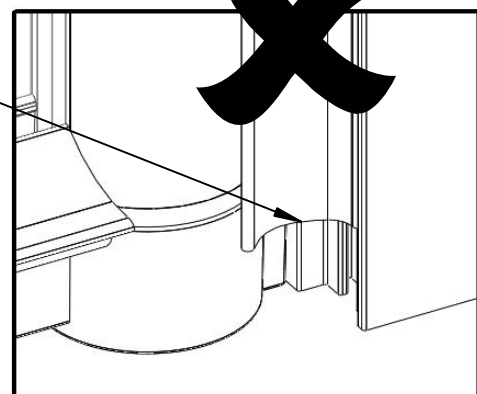

● F Intérieur ● GB Inside  
● I Interno  
● NL Binnenkant ● D Innen

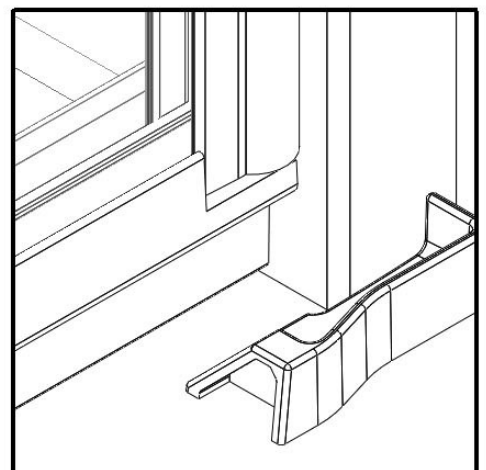
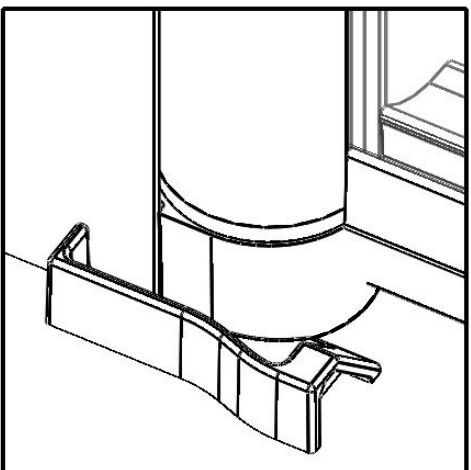
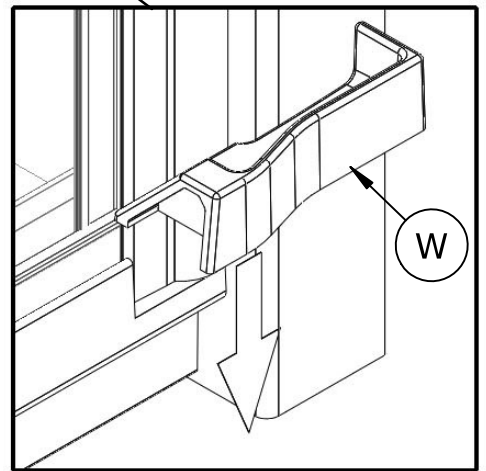
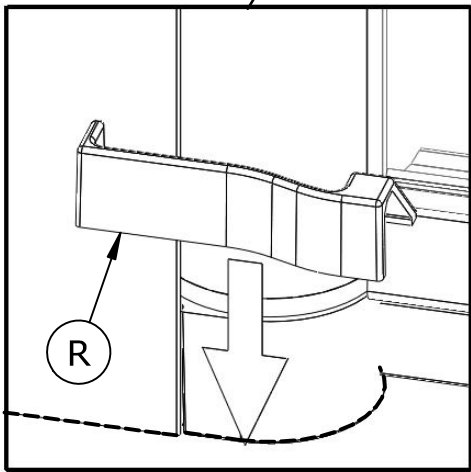
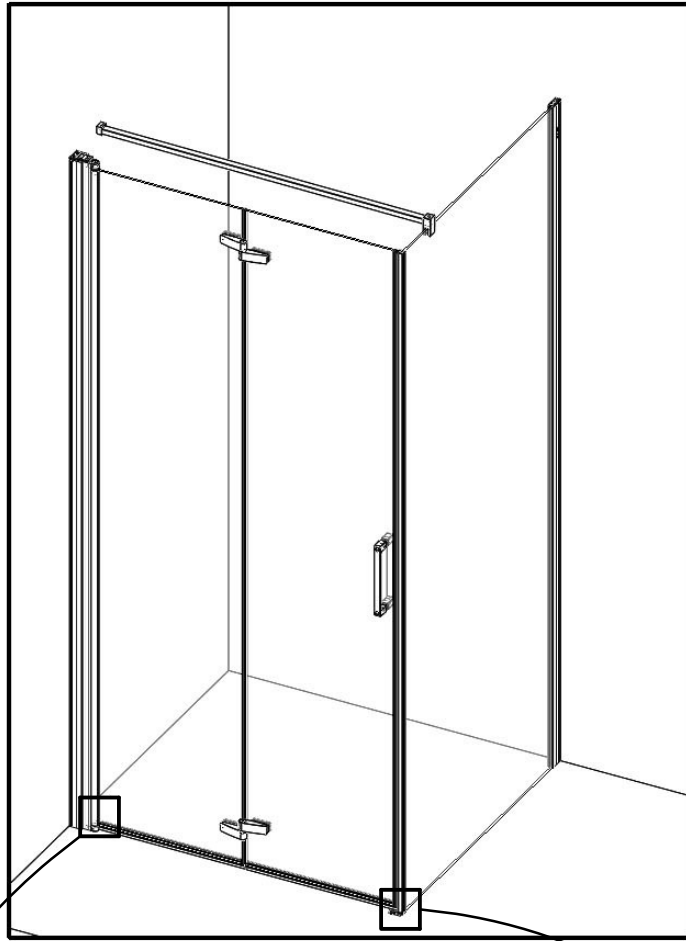

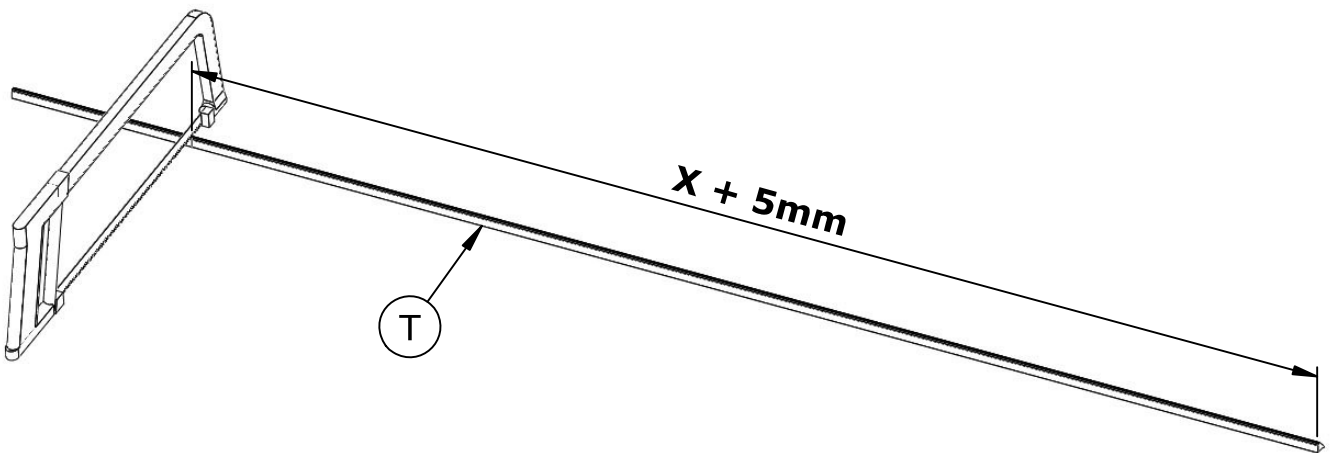
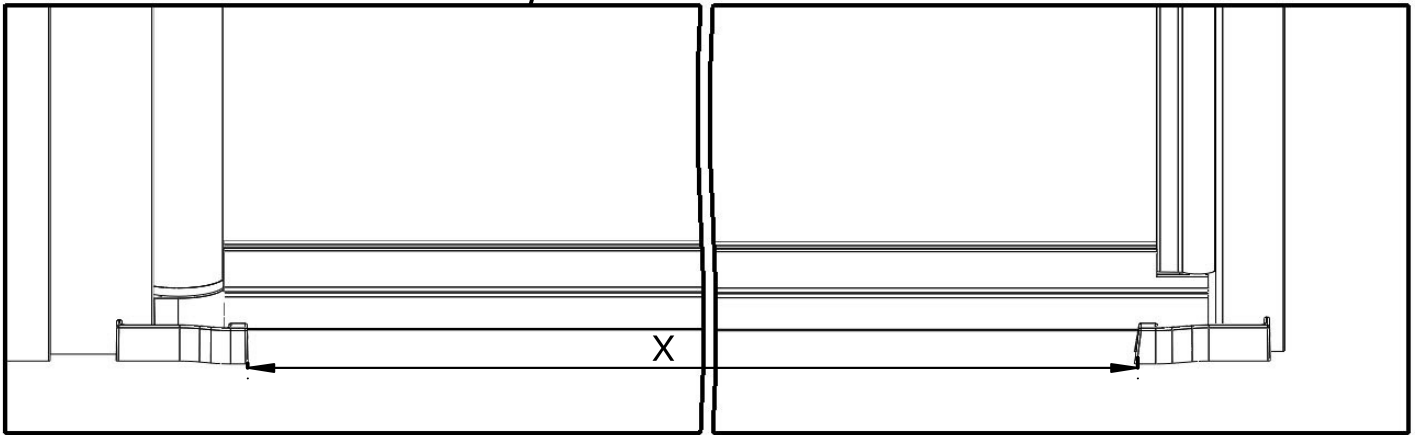
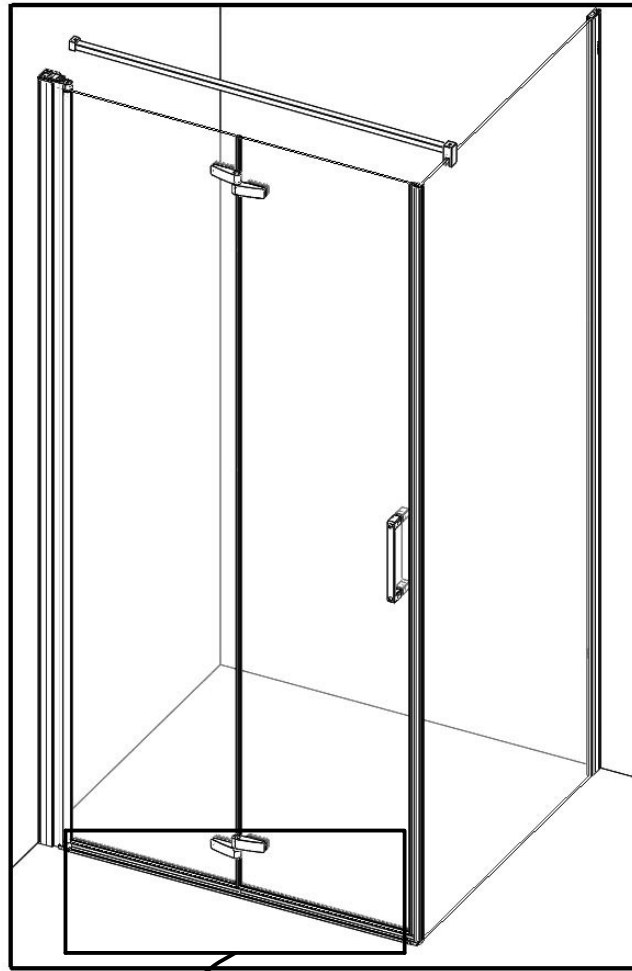

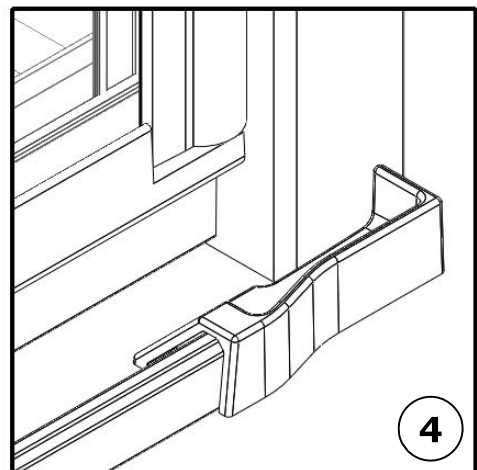
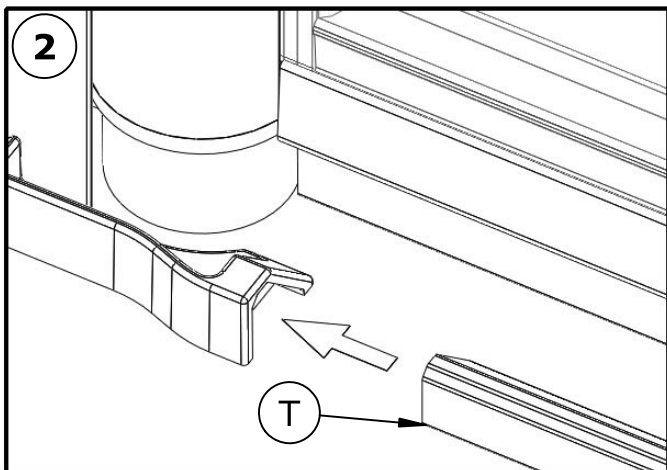
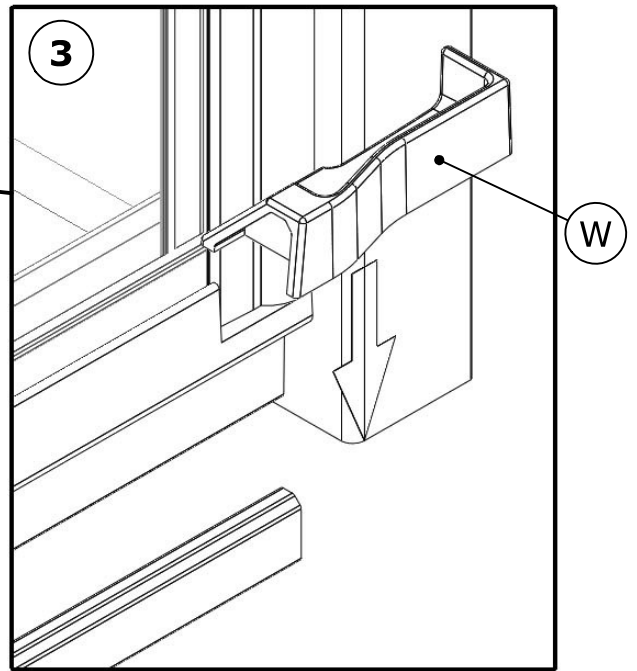
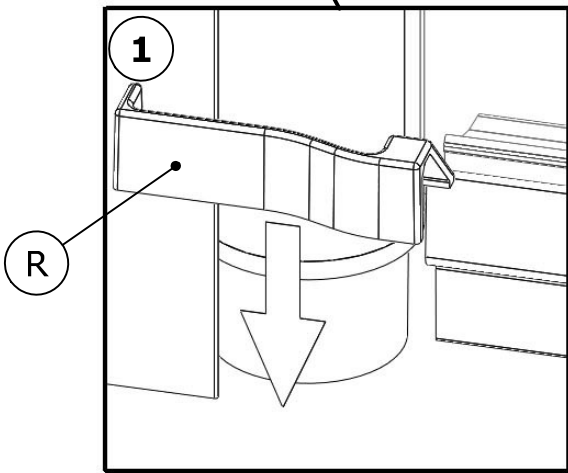
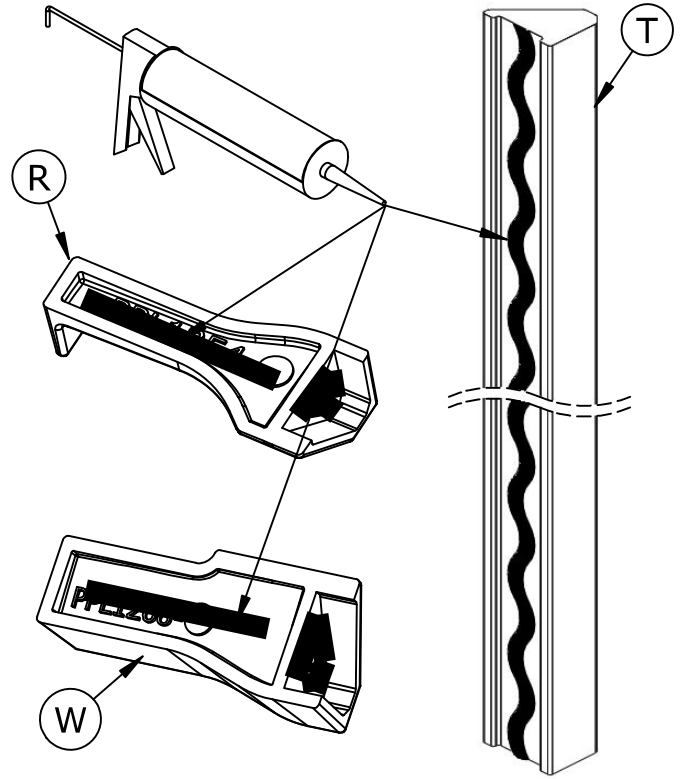
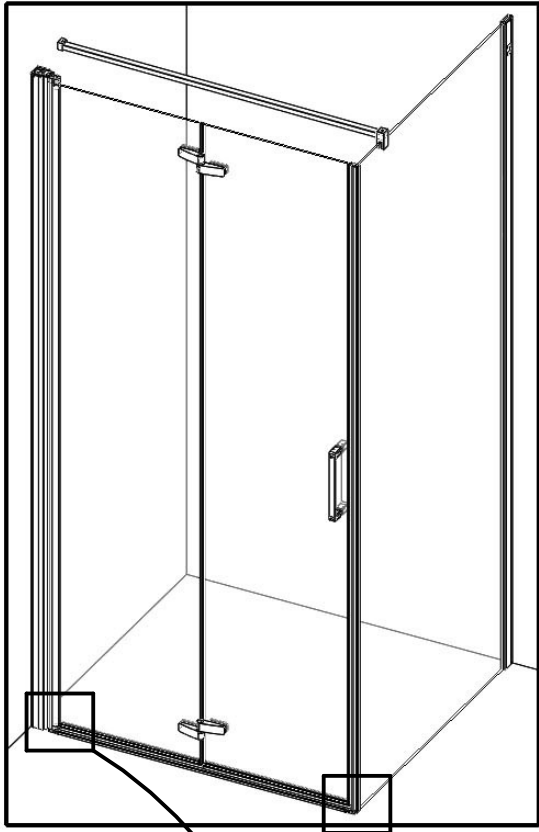

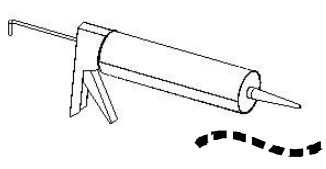

24h

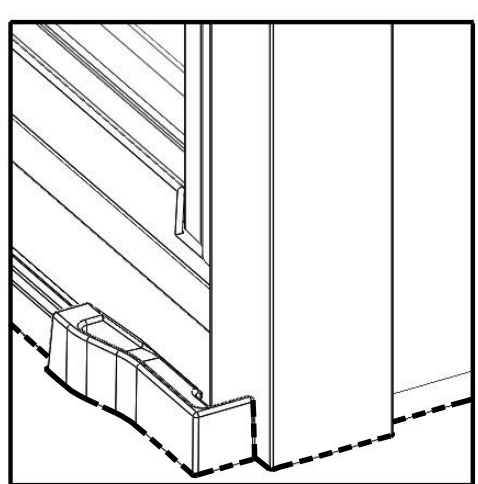
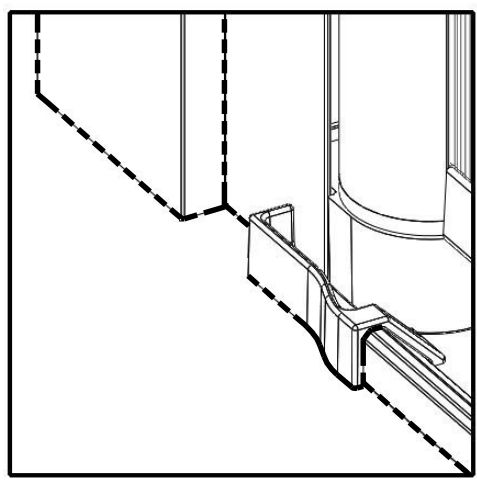
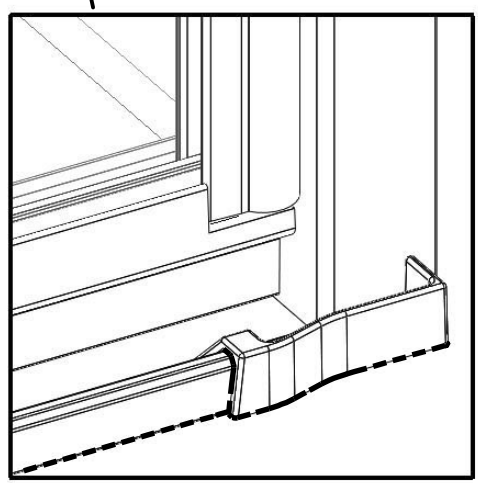
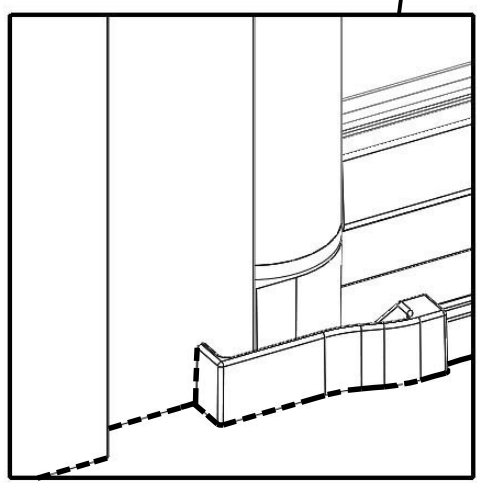
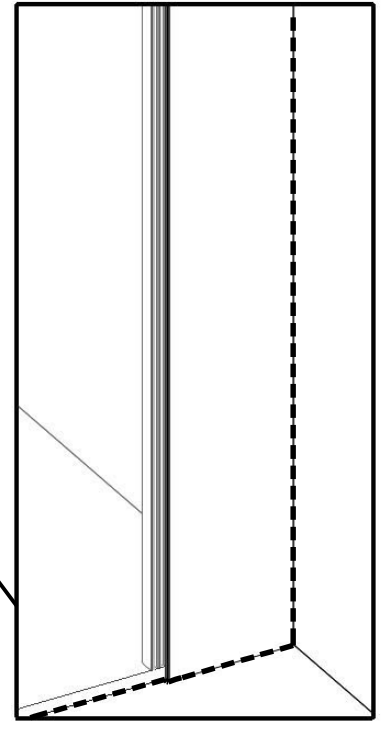
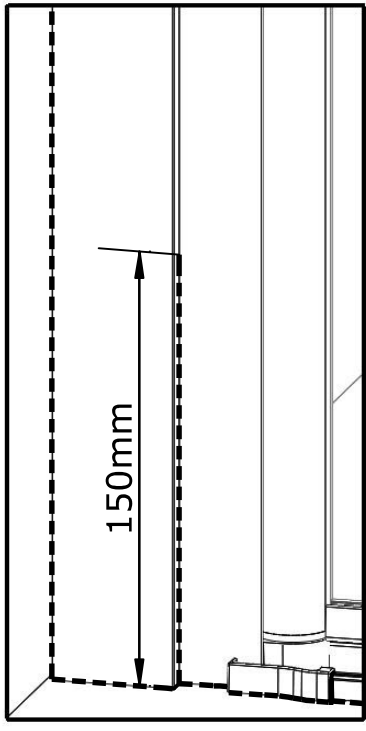
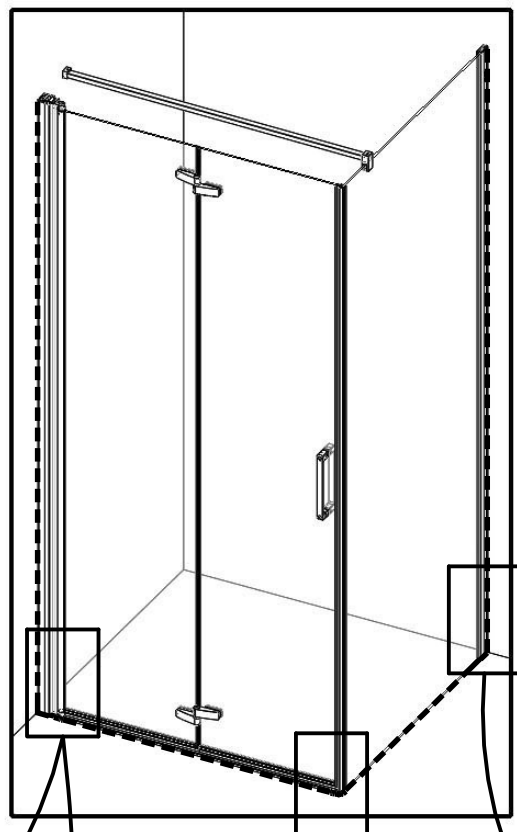







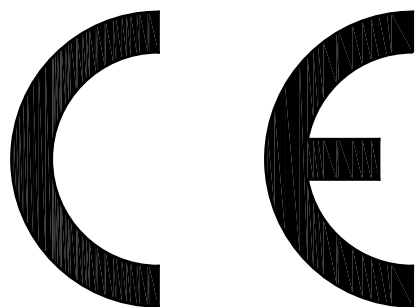

AQUAPRODUCTION, Site industriel,  
F - 44680 Chaumes-en-Retz

18

**EN 14428**

Paroi de douche, fabriquée en verre de silicate  
sodo-calcique de sécurité trempé thermiquement

Aptitude au nettoyage : réussite

Résistance à l'impact/propriétés de fragmentation : réussite

Durabilité : réussite



**SAV**  
**SERVICE HELPLINES**  
**ASSISTENZA POST-VENDITA**  
**SERVICIO POSTVENTA**

**FRANCE**

02 40 21 29 45

**UK**

020 8842 0033

**IRELAND**

04697 33102

**DEUTSCHLAND**

+49 (0) 6074 / 30928 0

**ITALIA**

(0382) 6181

**OSTEREICH**

+43 1 710 60 70

**SCHWEIZ**

(01) 748 17 44

**ESPANA**

93 544 60 76

**NEDERLAND**

+31 475 487 100

**BELGIE**

+31 475 487 100

**BELGIQUE**

+31 475 487 100

**РОССИЯ**

963 19 40, 773 67 22