

NOTICE DE MONTAGE INSTALLATION INSTRUCTIONS MANUAL DE INSTALACION MANUAL DE INSTALACAO ISTRUZIONI DI MONTAGGIO INSTALLATIE VOORSCHRIFTEN INSTALLATIONSANLEITUNG

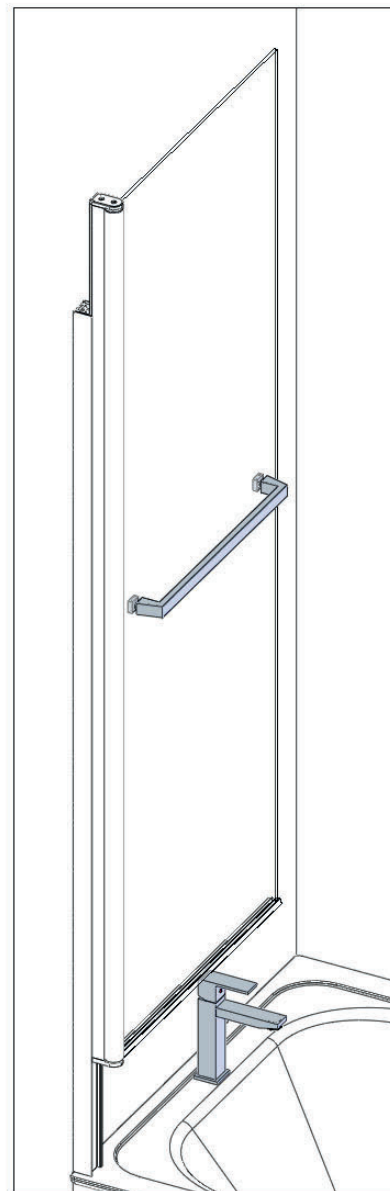

Attention aux étapes:
Check installation steps:
Atención a los pasos:
Atenção aos passos: P. 9 - 16
Attenzionz ai passi:
Let op de stappen:
Achtung vor den Schritten:

DES1581

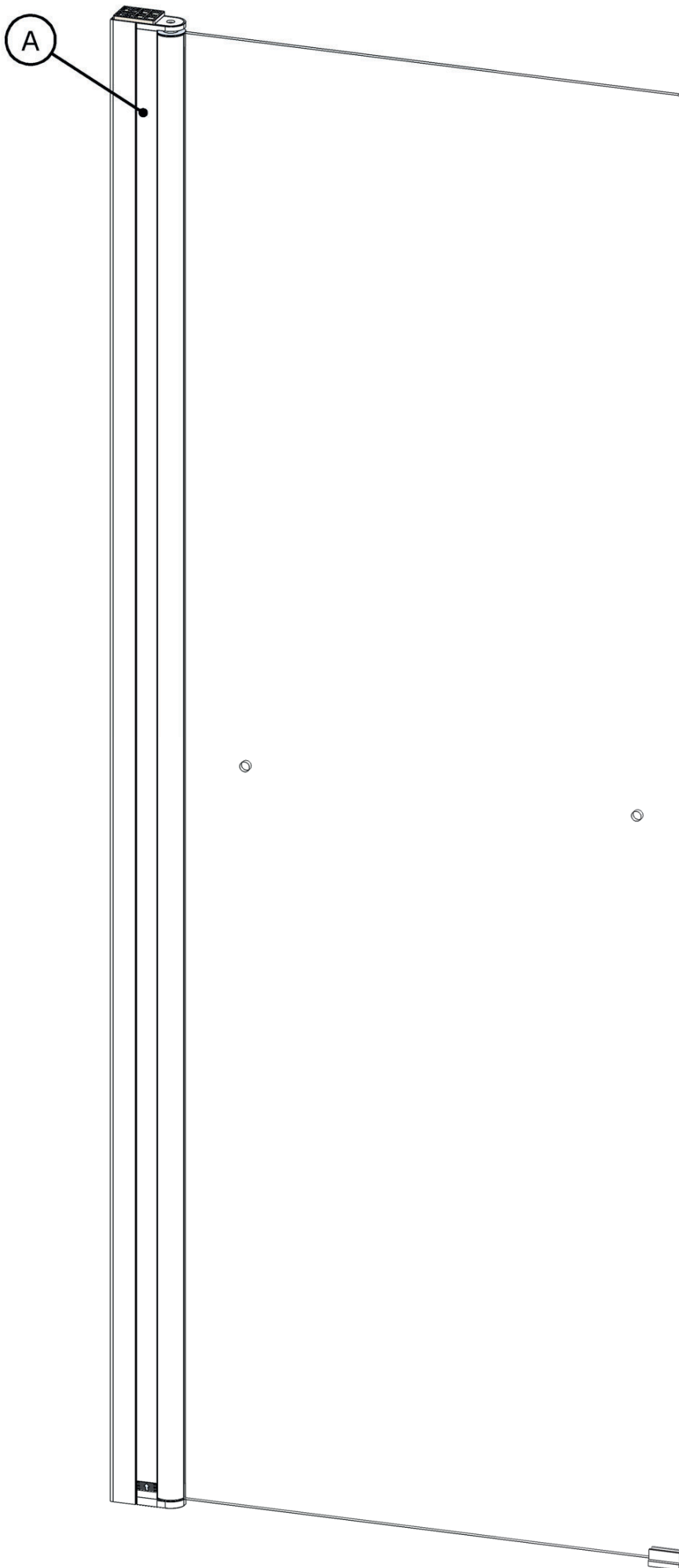

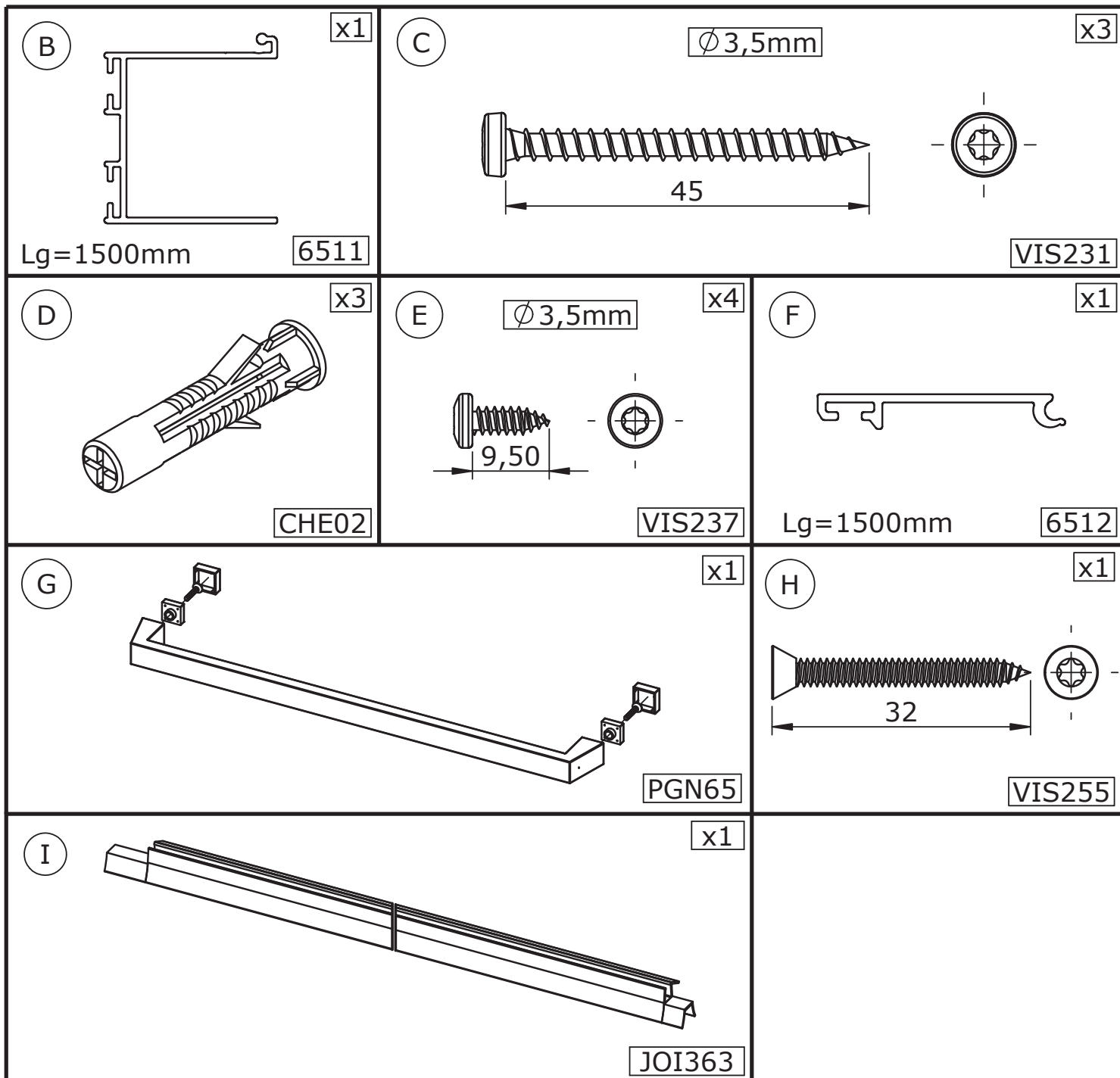

Les quantités données sont les quantités utiles au montage. les sachets fournis contiennent des pièces supplémentaires.

The quantities given are what are required for the installation. There may be some surplus in the package provide.

Las cantidades indicadas son las cantidades necesarias para el montaje. Las bolsitas incluidas contienen piezas suplementarias.

As quantidades indicadas são as quantidades necessárias para a montagem. Os sacos fechados contém peças adicionais.

Le quantità fornite sono le quantità necessarie al montaggio. I sacchetti forniti contengono pezzi supplementari.

De aangegeven aantallen zijn vereist voor de montage. De verpakking bevat extra onderdelen.

Die Mengenangaben beziehen sich auf die für die Montage nötigen Teile. Eventuell weitere beige packte Teile ignorieren.

Matériel nécessaire - Tools required
 Equipamiento necesario - Equipamento necessário
 Materiale necessario - Benodigd gereedschap - Benötigte Werkzeuge

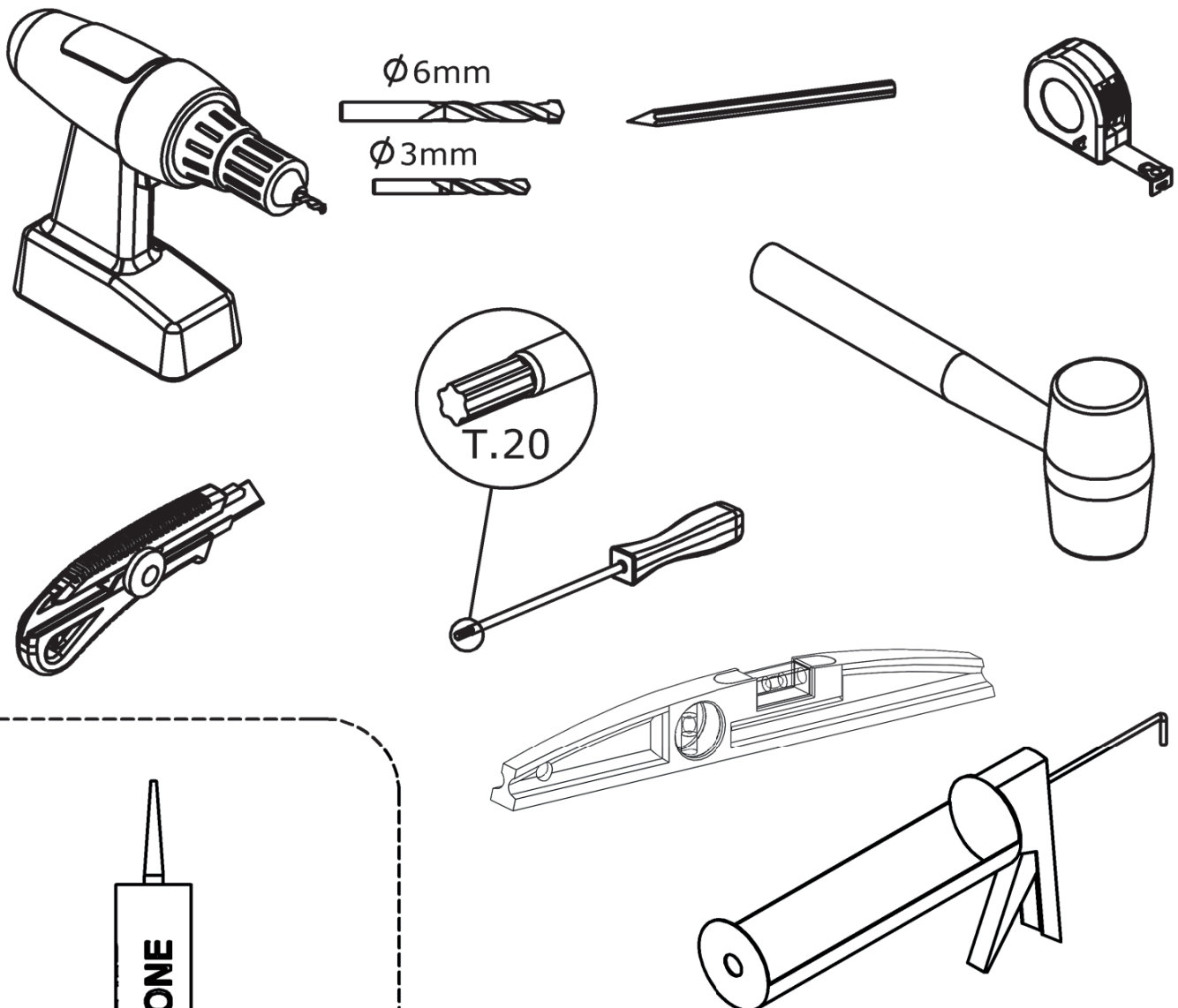

Utiliser un silicone adapté au matériau de chaque support (faïence, acrylique, etc.)

Use a silicone sealant that is intended for the surrounding materials (ceramic, acrylic, etc)

Usar una silicona adecuada para cada tipo de material (loza, acrílico, etc.)

Usar uma silicona adequada para cada tipo de material (loza, acrílico, etc.)

Utilizzare un silicone adatto a qualsiasi materiale (ceramica, acrilico, ecc.)

Gebruik siliconenkit die geschikt is voor iedere ondergrond (tegelwerk, acryl, etc.)

Für das jeweilige Trägermaterial (Stein, Acryl usw.) geeignetes Silikon verwenden.

Non fourni - Not provided
 No entregados - Não entregues
 Non fornito
 Niet meegeleverd - Nicht geliefert



REVERSIBILITE - REVERSIBILITY - REVERSIBILIDAD - REVERSIBILIDADE
 REVERSIBILITA - OMKEERBAARHEID - WAHLWEISE MONTAGE

Montage à gauche
 Left hand
 Montaje a la izquierda
 Montagem à esquerda
 Montaggio sinistra
 Montage links
 Montage links

Montage à droite
 Right hand
 Montaje a la derecha
 Montagem à direita
 Montaggio a destra
 Montage rechts
 Montage rechts

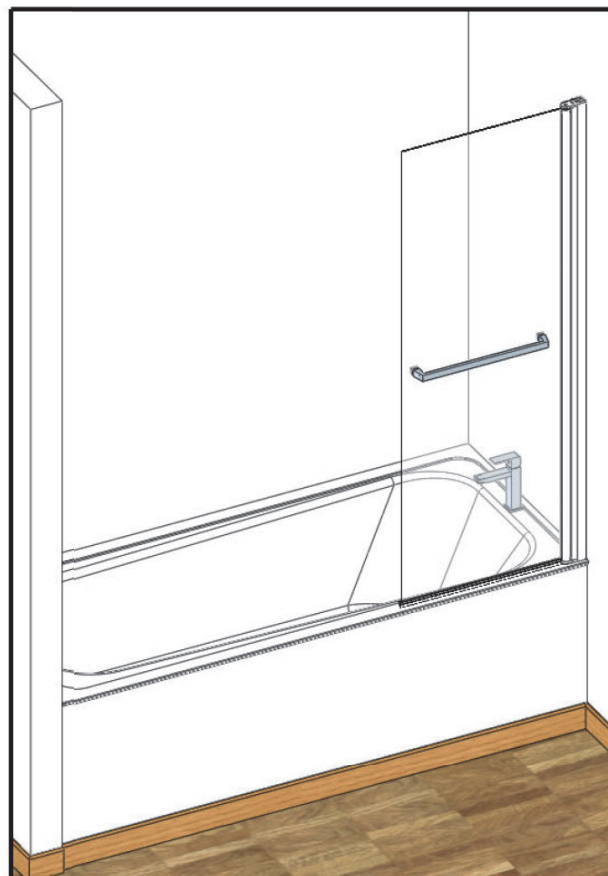

- Vous avez la possibilité de réaliser un montage à droite ou un montage à gauche. Notre notice d'installation décrit un montage à gauche. Si vous voulez réaliser un montage à droite, il vous suffit d'inverser le montage.

- This cubicle can be installed either left or right hand. These installation instructions show a left hand installation.

- Puede realizar un montaje a la derecha o un montaje a la izquierda. Nuestro folleto de instalación describe un montaje a la izquierda. Si desea montar su cabina a la derecha sólo tendrá que realizar el montaje al contrario.

- Pode realizar uma instalação à direita ou uma instalação à esquerda. O nosso manual de instalação descreve uma instalação à esquerda. Se pretende realizar uma instalação à direita, basta inverter a instalação.

- Avete la possibilità di effettuare il montaggio a destra o a sinistra. Il nostro manuale descrive il montaggio a sinistra. Se volete realizzare il montaggio a destra è sufficiente invertire varie fasi di montaggio.

- U kunt de douchecabine rechts of links monteren. Onze handleiding beschrijft de links montage van de cabine. Keer de montage om als u de cabine rechts wilt monteren.

- Sie haben die Möglichkeit, eine Montage auf der linken Seite oder eine Montage auf der rechten Seite durchzuführen. Unsere Montageanleitung beschreibt eine Montage auf der linken Seite. Wenn Sie die Montage lieber auf der rechten Seite durchführen wollen, müssen Sie nur den Montageprozess umkehren.

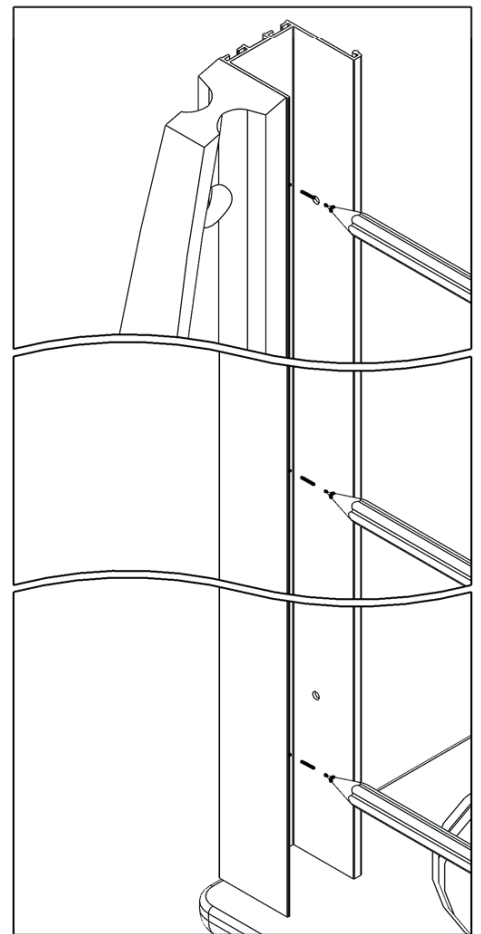
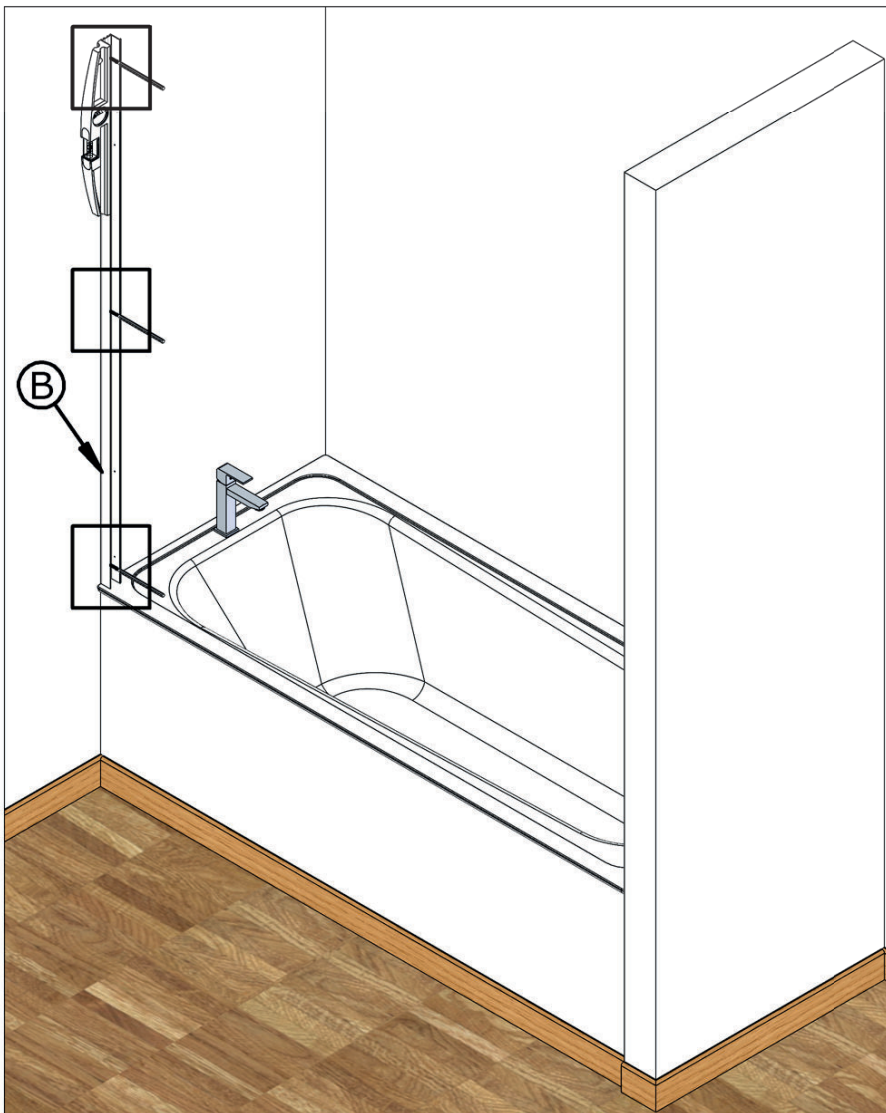
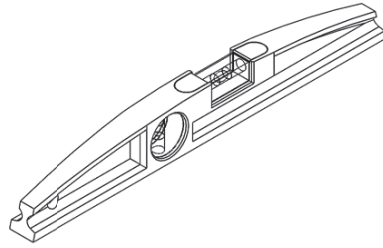
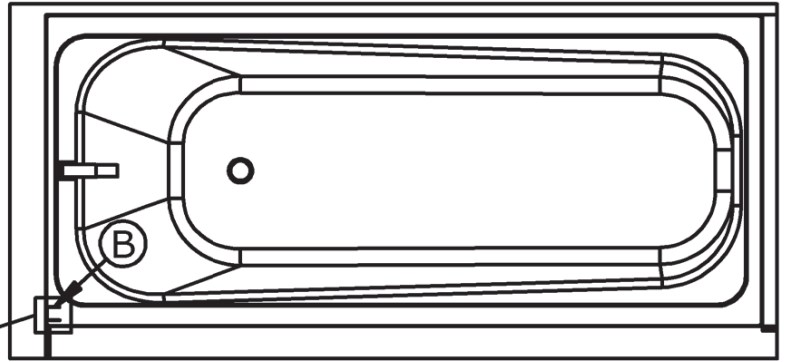
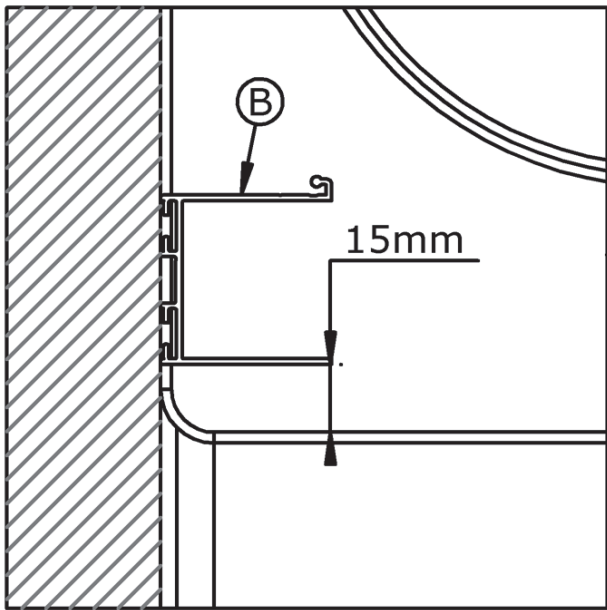

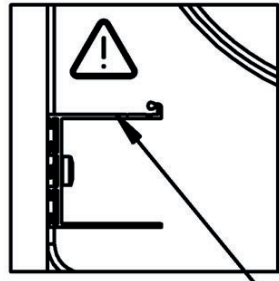
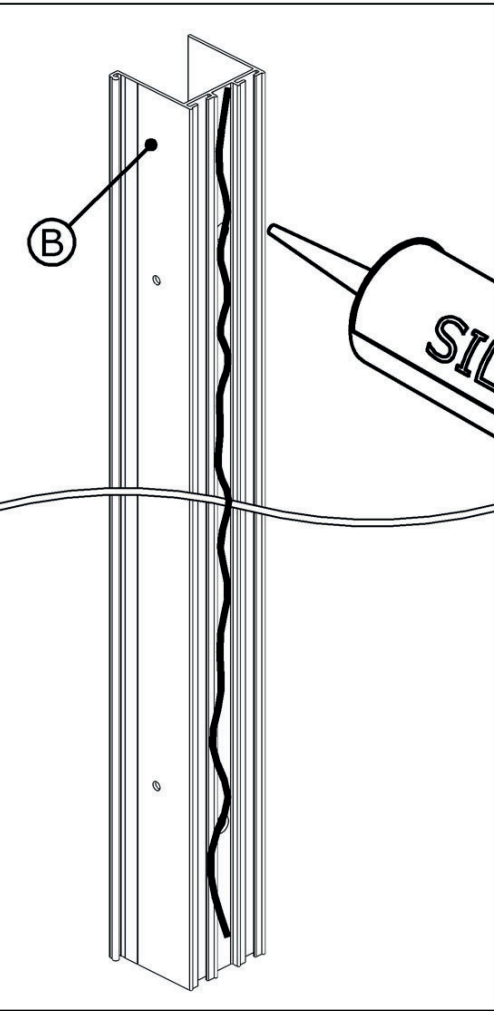
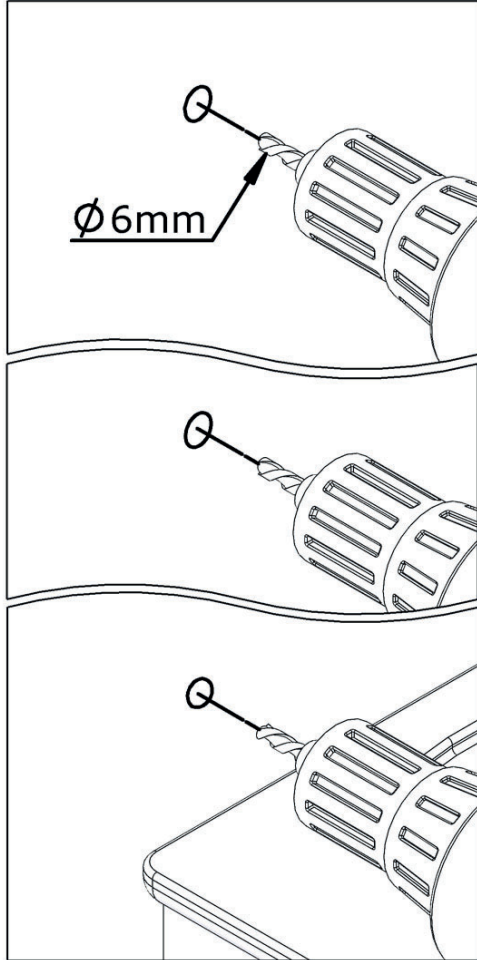

Intérieur
 Inside
 Interior
 Interior
 Interna
 Binnenkant
 Innen

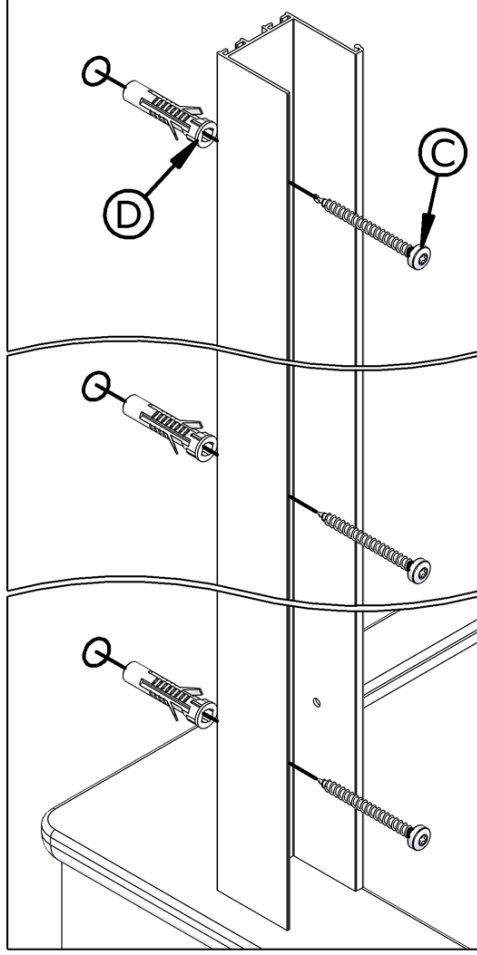

Gauche - Left - Izquierda
Esquerda - Sinistra - Links
links

Droite - Right - Derecha
Direita - Destra - Rechts
Rechts

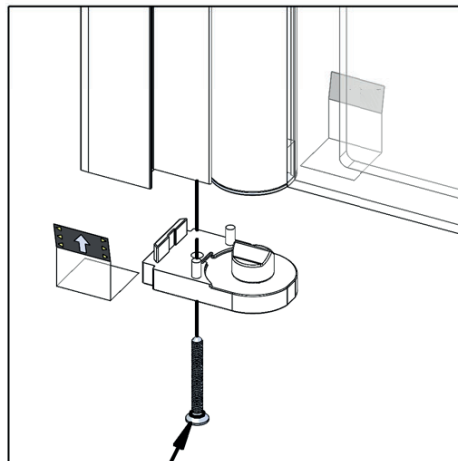
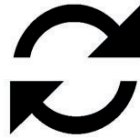
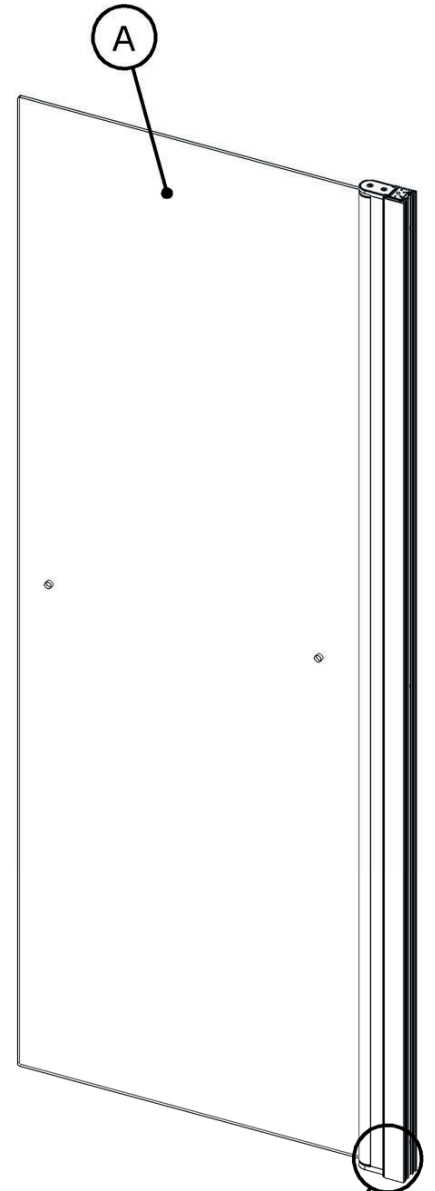
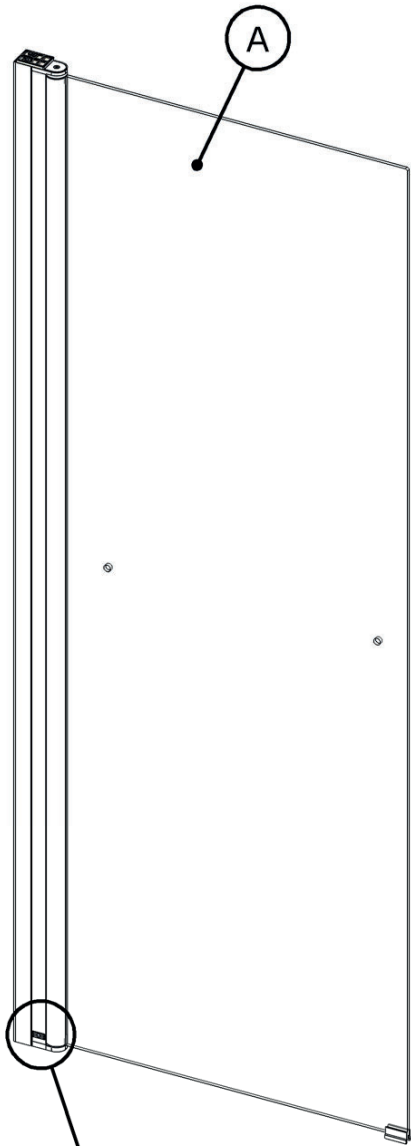

H

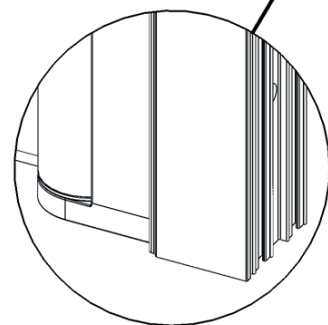
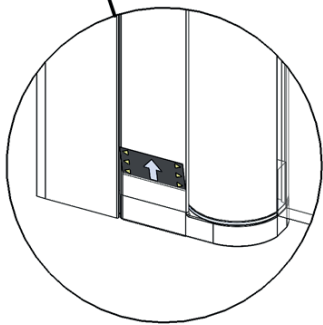

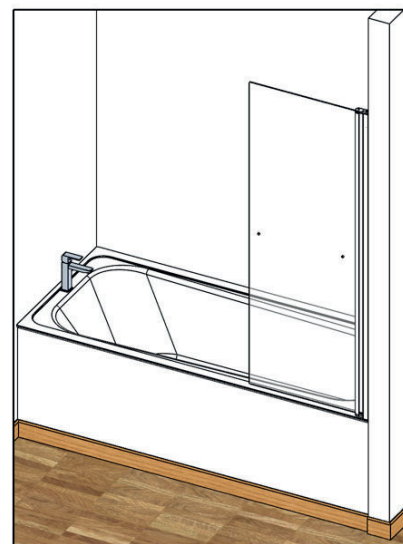
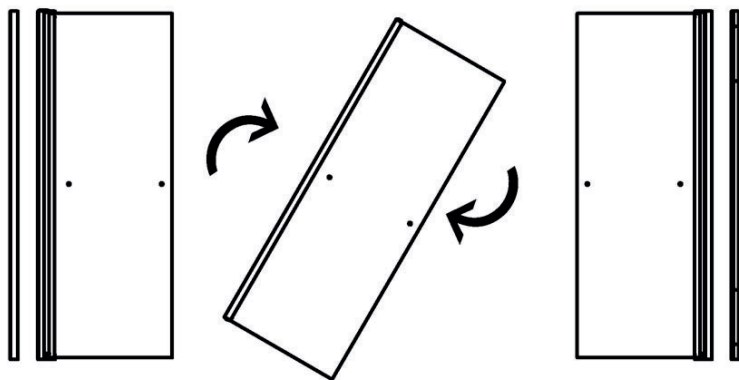

Montage à droite
 Right hand
 Montaje a la derecha
 Montagem à direita
 Montaggio a destra
 Montage rechts
 Montage rechts

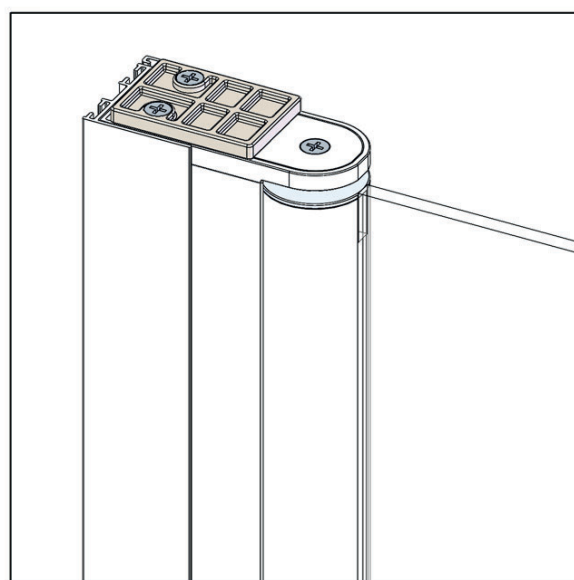
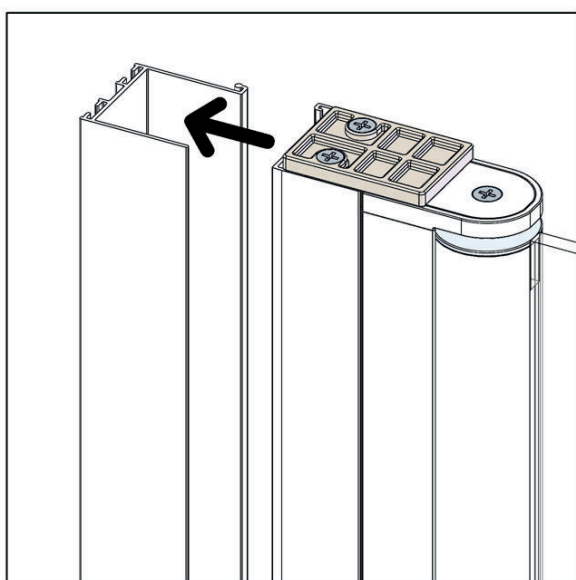
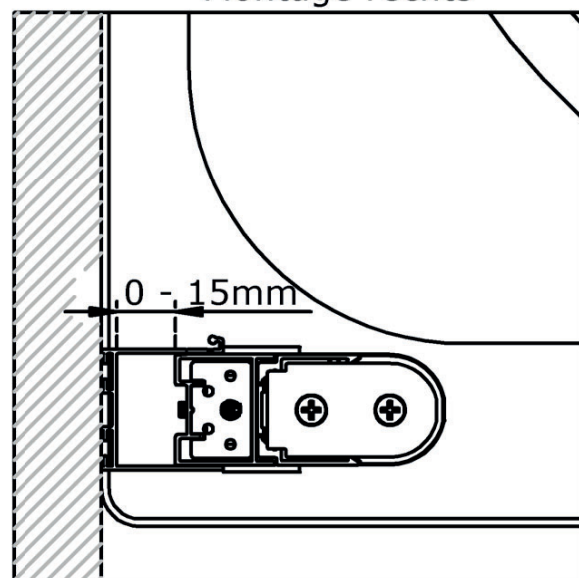

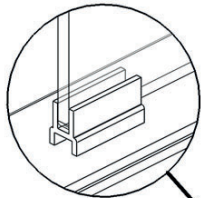
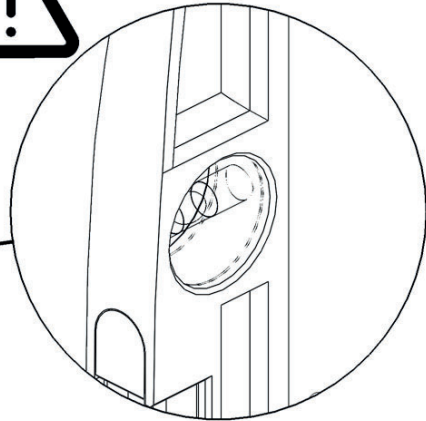
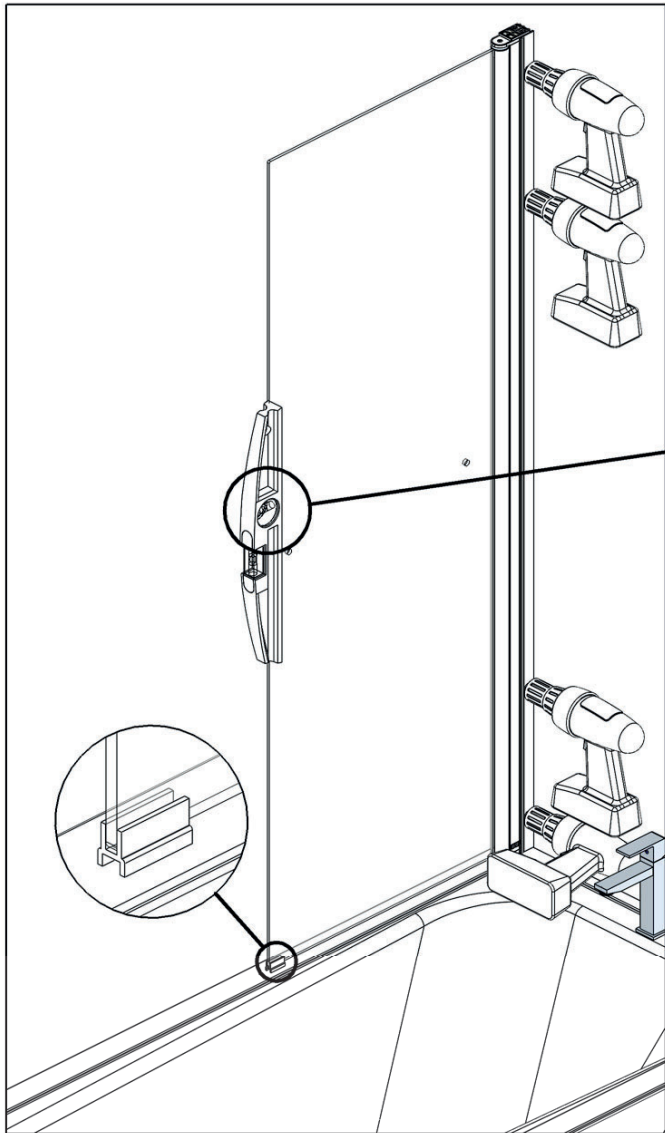

Intérieur douche - Inside shower
 Interior ducha - Interior duche
 Doccia interna
 Binnenkant van de douche
 Innenraum der kabine

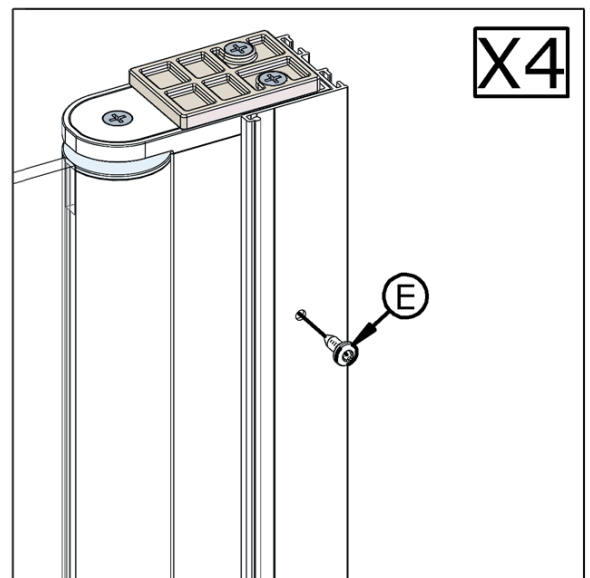
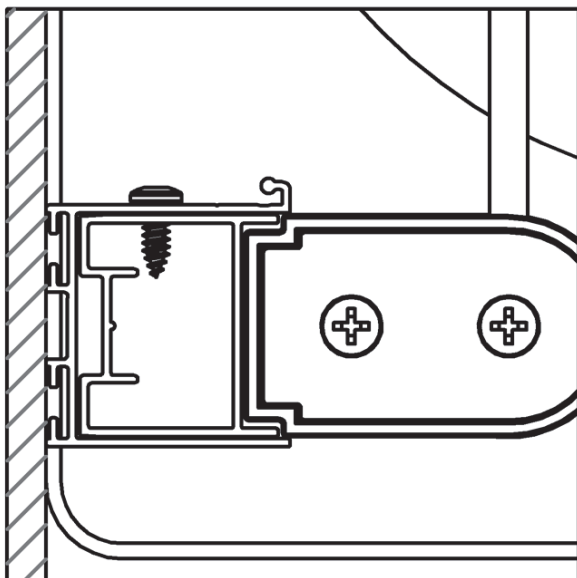
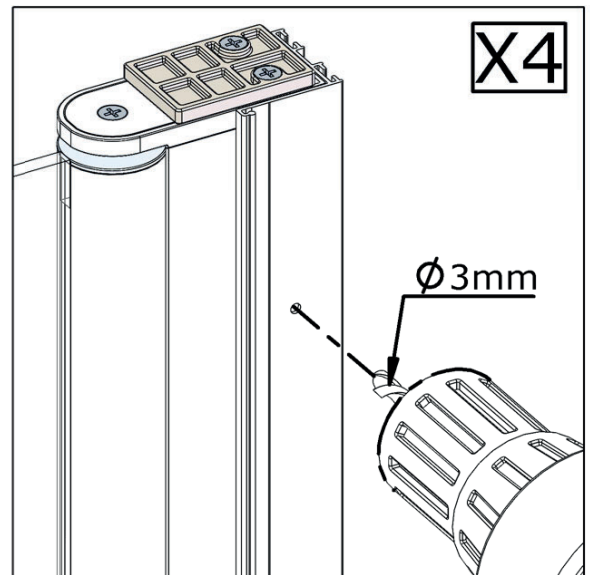

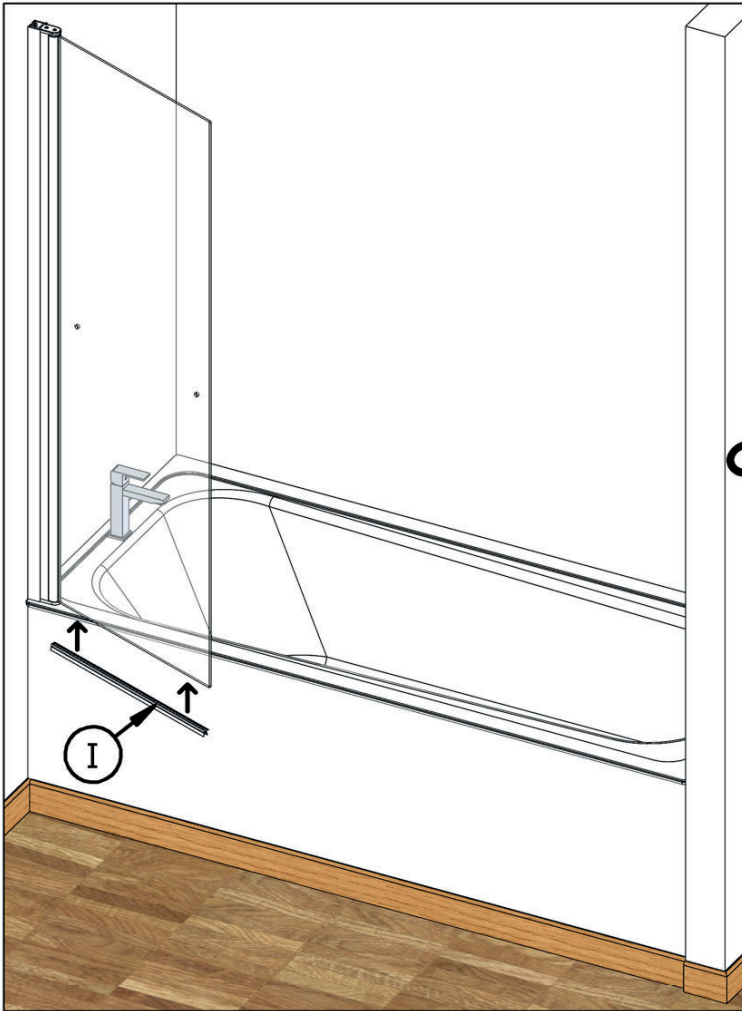

Intérieur douche
Inside shower
Interior ducha
Interior duche
Doccia interna
Binnenkant van de douche
Innenraum der kabine

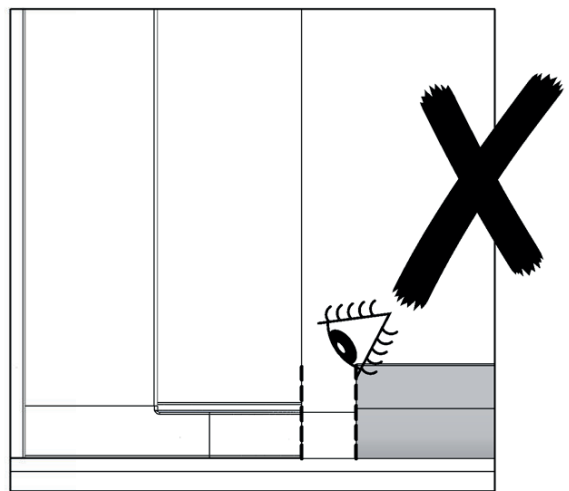
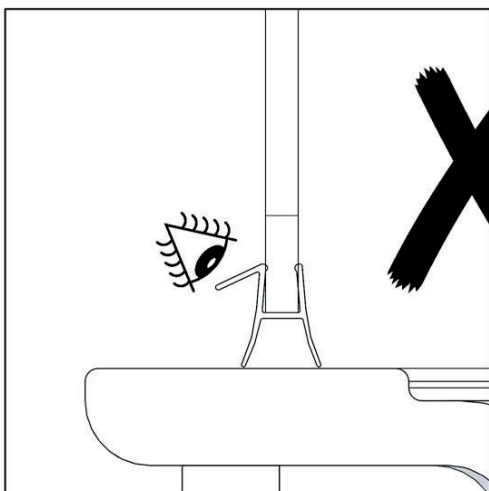
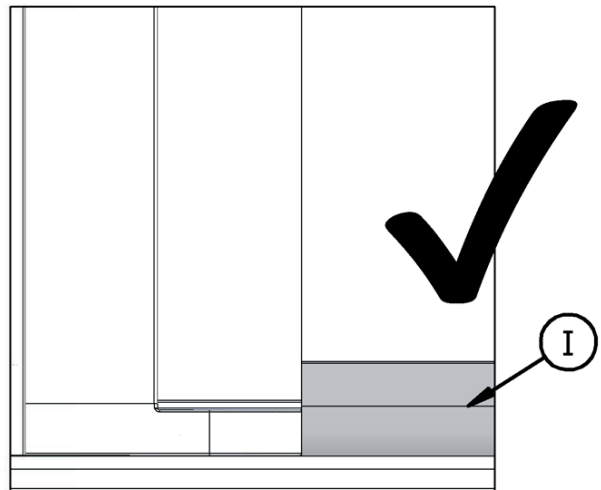
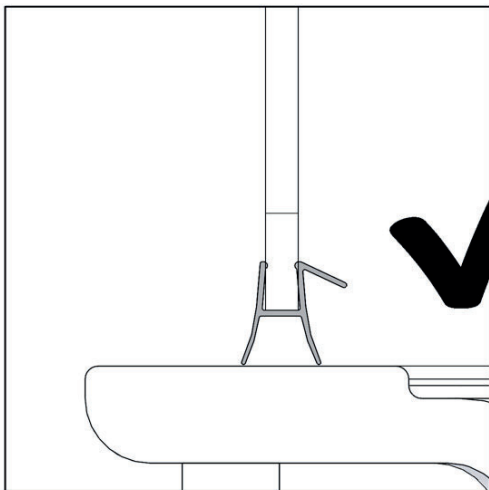
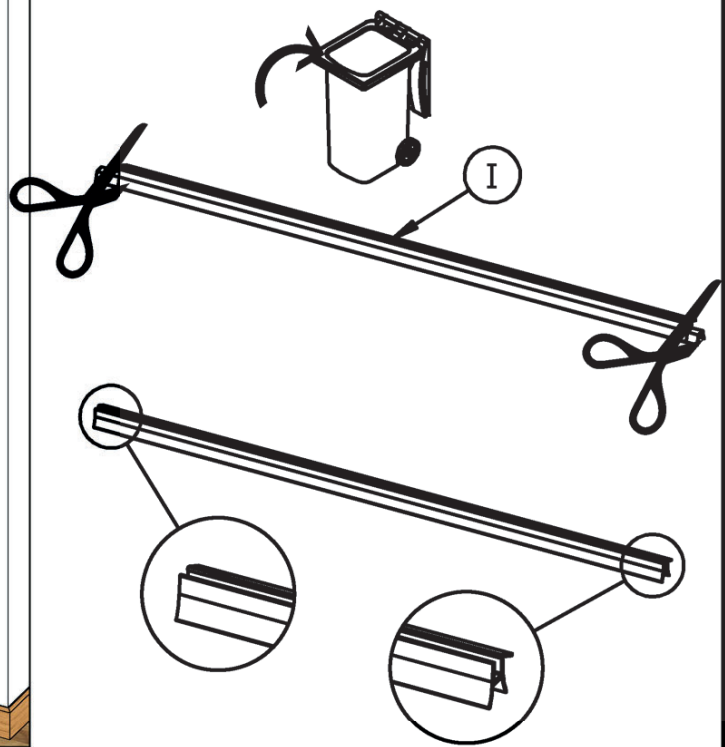

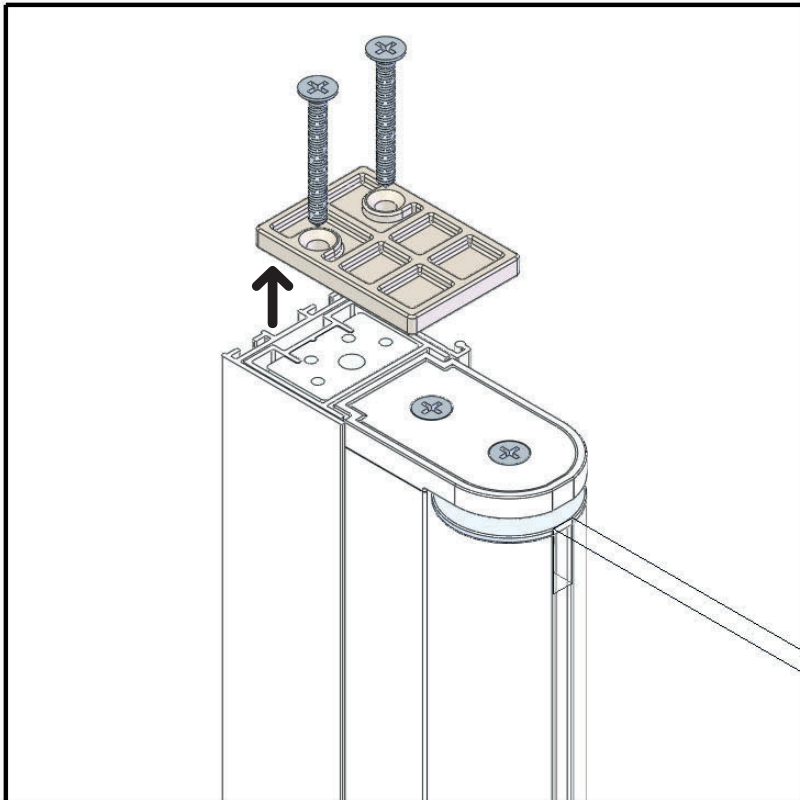

InteRetirer - Remove
Quitar - Retirar - Togliere
Verwijderen - Entfernen

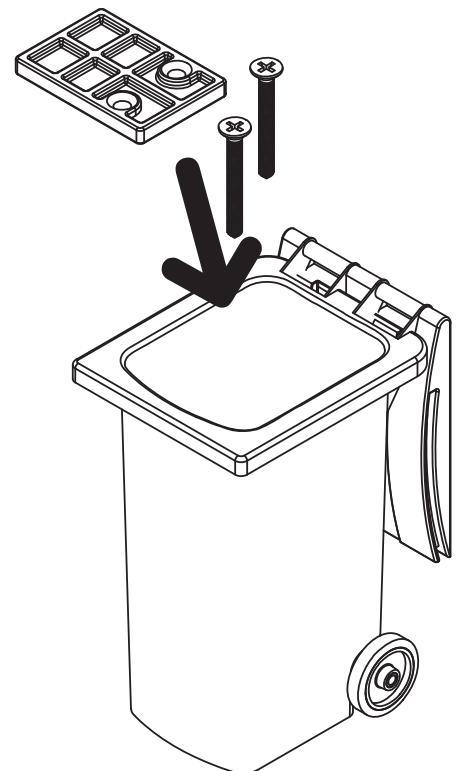

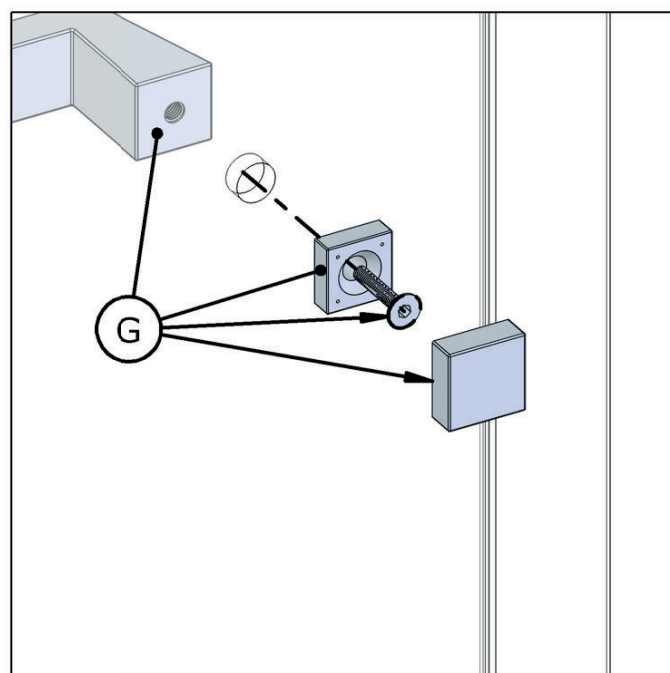
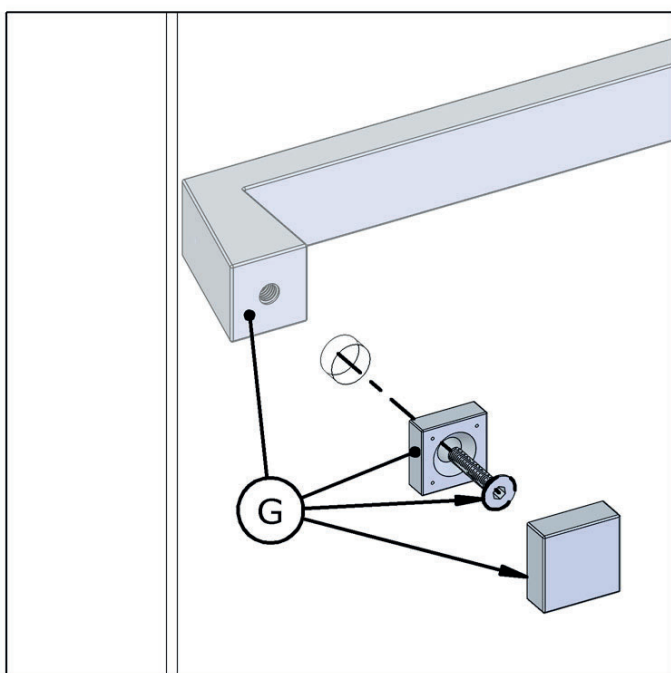

Intérieur douche - Inside shower
 Interior ducha - Interior duche
 Doccia interna
 Binnenkant van de douche - Innenraum der kabine

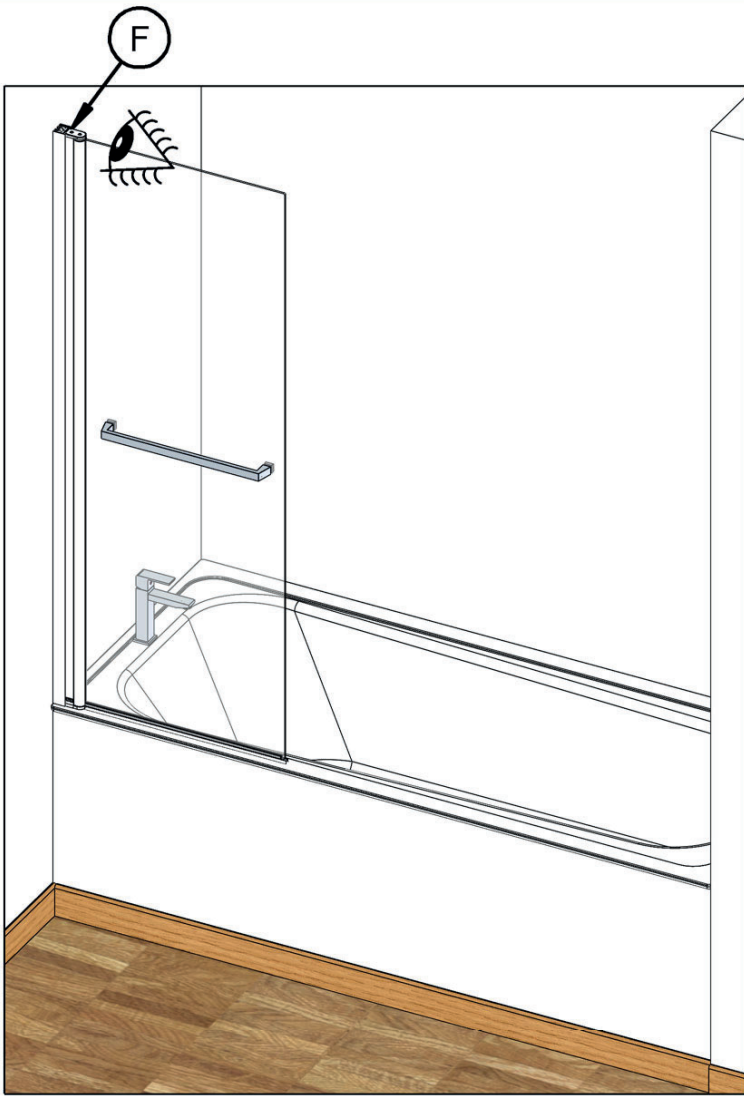

Intérieur douche - Inside shower
 Interior ducha - Interior duche
 Doccia interna
 Binnenkant van de douche
 Innenraum der kabine

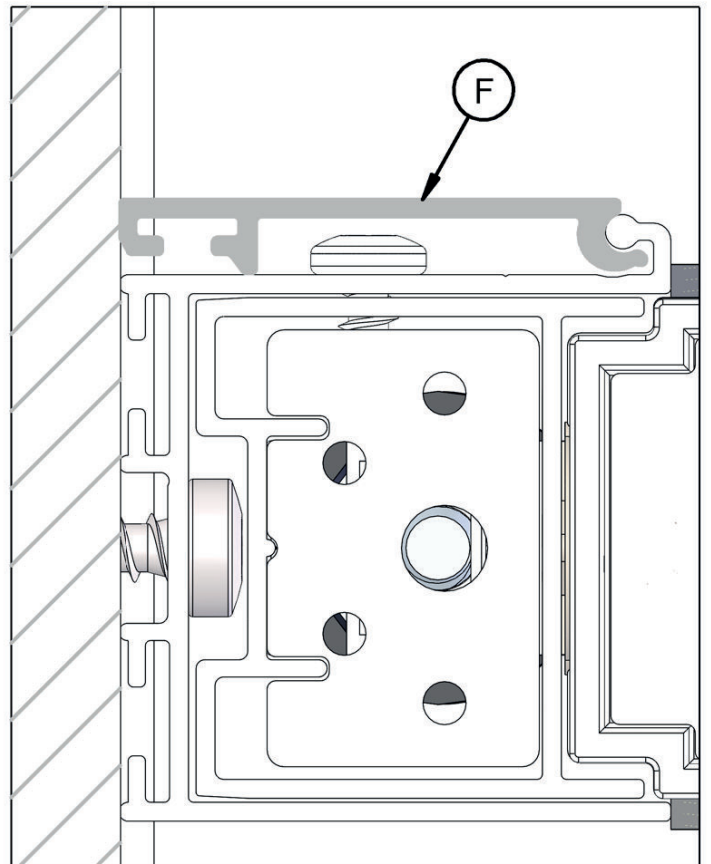
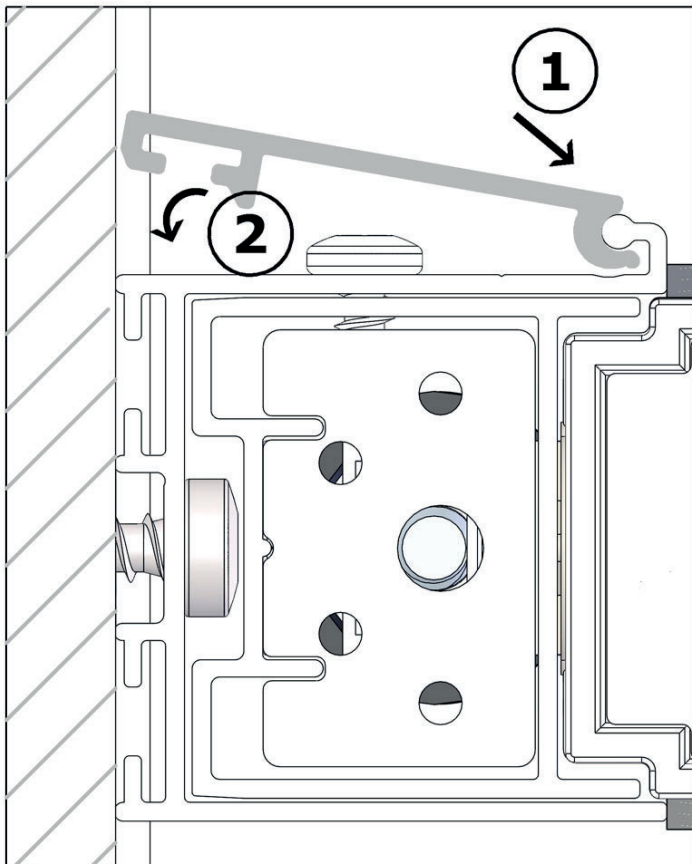

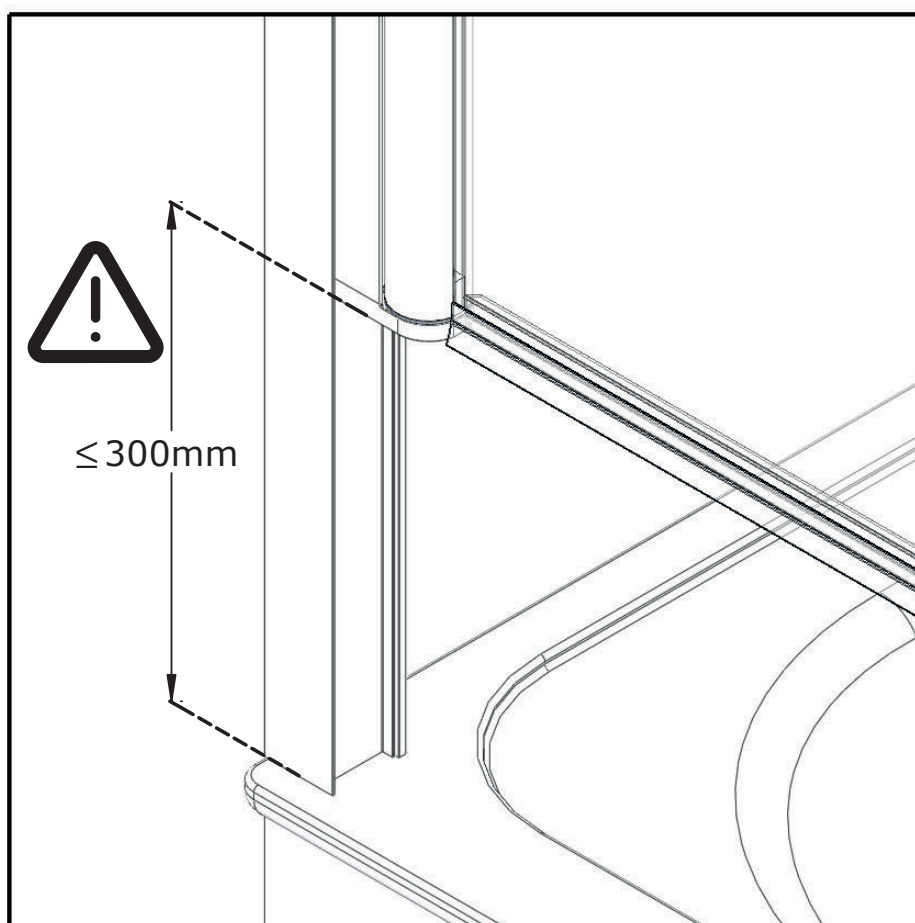

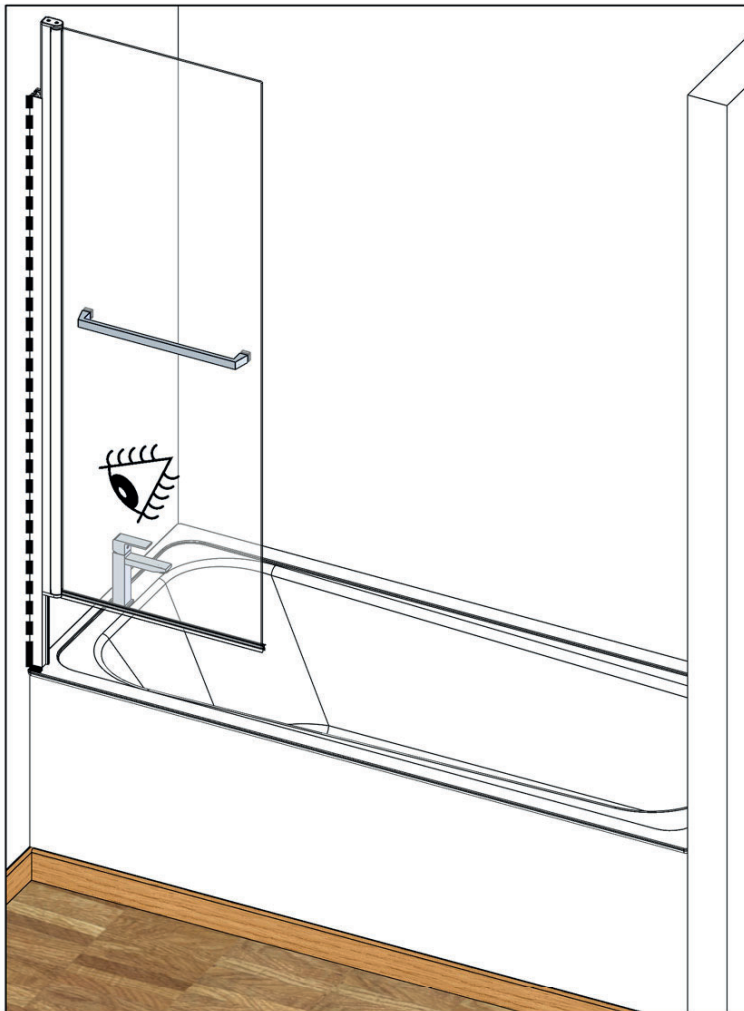

24h

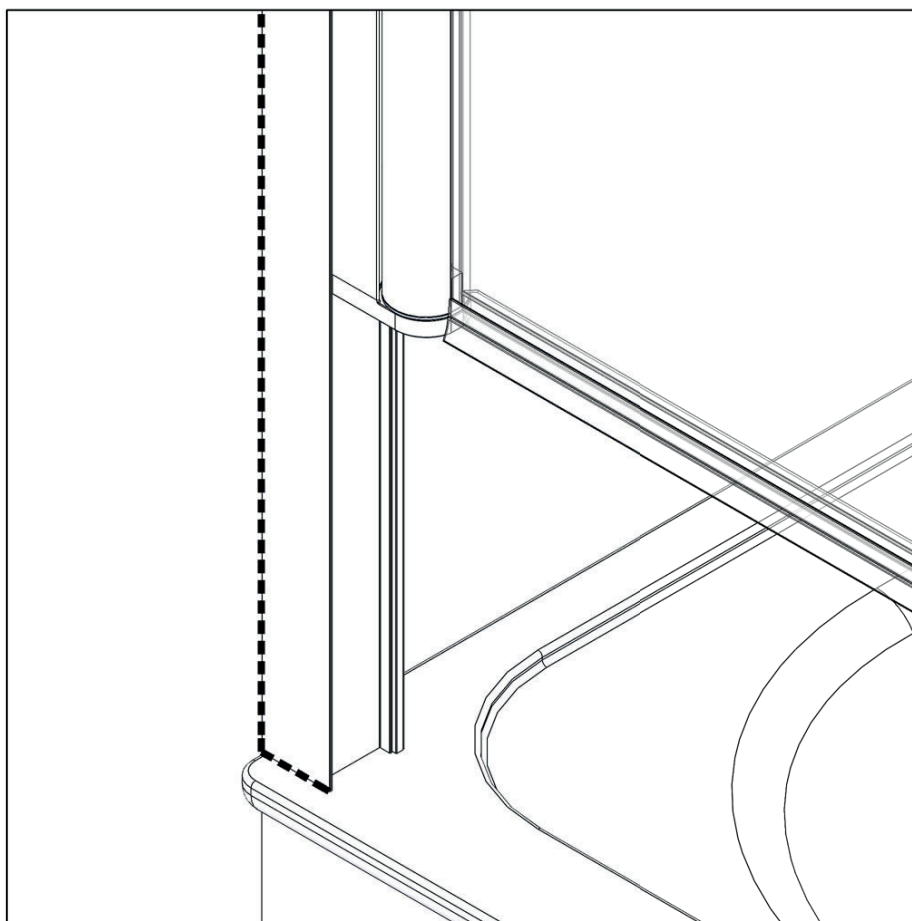

**NOTICE D'ENTRETIEN
MAINTENANCE INSTRUCTIONS
ISTRUZIONI DI MANUTENZIONE
INSTRUCCIONES DE MANTENIMIENTO
ONDERHOUDSINSTRUCTIE
WARTUNGSANLEITUNG**

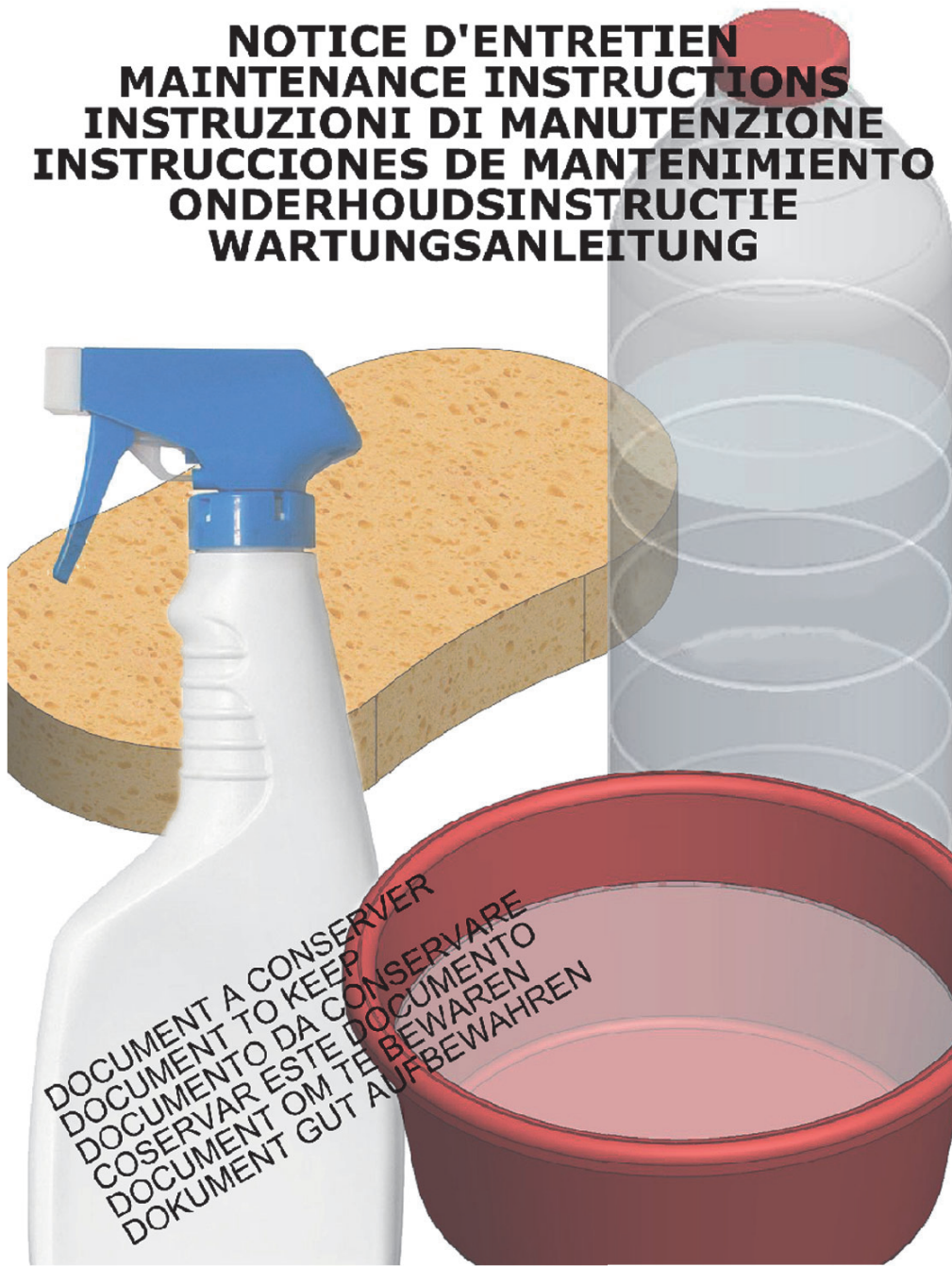

SCAN ME





AQUAPRODUCTION, Site industriel,
F - 44680 Chaumes-en-Retz

22

EN 14428

Paroi de douche, fabriquée en verre de silicate
sodo-calcique de sécurité trempé thermiquement

Aptitude au nettoyage : réussite

Résistance à l'impact/propriétés de fragmentation : réussite

Durabilité : réussite



SERVICE APRÈS-VENTE AFTER-SALES SERVICE

FRANCE

+33 (0)2 40 21 29 45

UK

+44 (0)20 8842 0033

IRELAND

+353 04697 33102

DEUTSCHLAND

+49 (0) 6074 / 30928 0

ITALIA

+39 (0382) 6181

ÖSTEREICH

+43 1 710 60 70

SUISSE/SCHWEIZ

+41 (0)32 631 04 74

ESPAÑA

+34 93 544 60 76

NEDERLAND

+31 475 487 100

BELGIQUE/BELGIË

+31 475 487 100

РОССИЯ

+7 495 258-29-51

PORTUGAL

+351 219 112 785