

- F Notice de montage (version pivotante) ● GB Installation instructions (pivoting version)
- E Manual de instalación (versión giratoria) ● I Istruzioni di montaggio (versione girevole)
- NL Installatie voorschriften (draaibare versie) ● D Installationsanleitung (schwingtür)

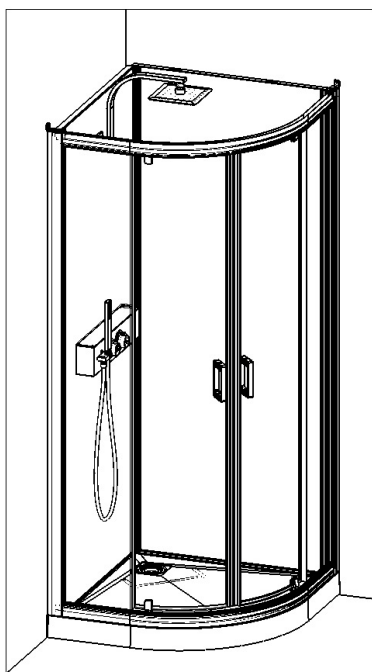

- F Attention aux étapes :
- GB Check installation steps :
- E Atención a los pasos :
- I Attenzione ai passi :
- NL Aandacht voor de stappen :
- D Achtung vor den Schritten :

P. 12 - 13 - 14

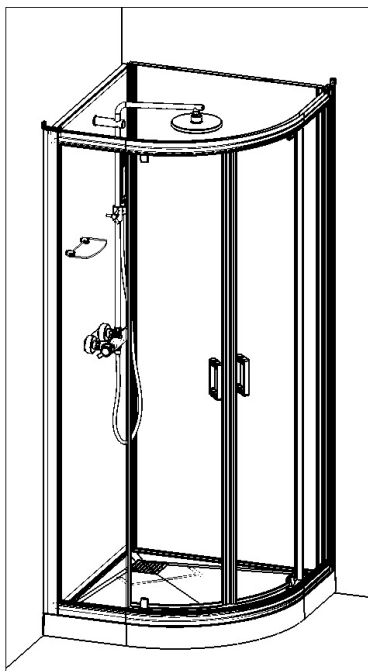
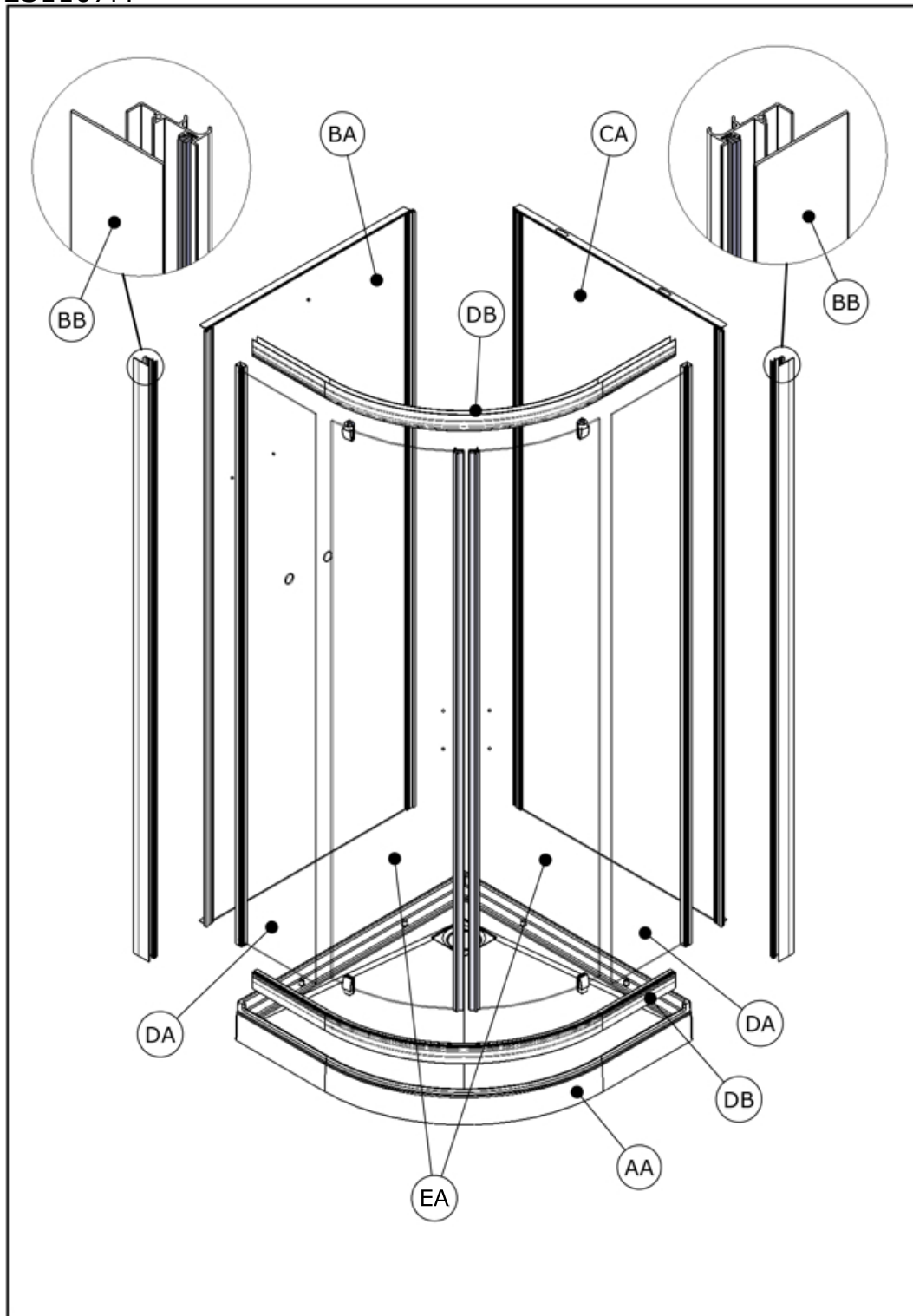

# EDEN 2

Rep	80R		90R		Qté
	BAS/LOW	HAUT/HIGH	BAS/LOW	HAUT/HIGH	

## COLIS 1

AA	REC415	REC421	REC416	REC422	1
AB	BOND14				1
AC	TOL54				1
AD	TUY62				1
AE	JOI292				1

## COLIS 2

BA	C9801				1
BB	5003C02				2
BC	S1555-A				1

## COLIS 3

CA	C9759				1
----	-------	--	--	--	---

## COLIS 4

DA	C9787				1
DB	4194				2
DC	VIS214				8
DD	JOI236				2
DE	JOI231				2
DF	MOU25/MOU26				4
DG	S2117				1

## COLIS 5

EA	C9763				1
EB	JOI233				2
EC	JOI311				2
ED	S1881				1
EE	PGN36C				2

## BOITE B1171

FA	MIT97				1
FB	KIT223				1
FD	KIT76				1
FE	KIT180				1
FF	FLEX05				1
FG	VER4288				1
FH	AV085				2
FJ	SET89				1
FK	TOL89				1
FO	TUY66 + TUY67				1

## EDEN 2+

Rep	80R		90R		Qté
	BAS/LOW	HAUT/HIGH	BAS/LOW	HAUT/HIGH	
COLIS 1					
AA	REC415	REC421	REC416	REC422	1
AB	BOND14				1
AC	TOL54				1
AD	TUY62				1
AE	JOI292				1

### COLIS 2

BA	C9803	C9804	1
BB	5003C02		2
BC	S1555-A		1

### COLIS 3

CA	C9759	C9760	1
----	-------	-------	---

### COLIS 4

DA	C9787	C9789	1
DB	4194		2
DC	VIS214		8
DD	JOI236		2
DE	JOI231		2
DF	MOU25/MOU26		4
DG	S2117		1

### COLIS 5

EA	C9763		1
EB	JOI233		2
EC	JOI311		2
ED	S1881		1
EI	PGN36C		2

### BOITE B1172

FC	S2029		1
FD	KIT125		1
FE	JOI223		1
FF	KIT124		1
FG	FLEX05		1
FH	KIT76		1
FI	KIT113		1



# Colis 1

## S1552

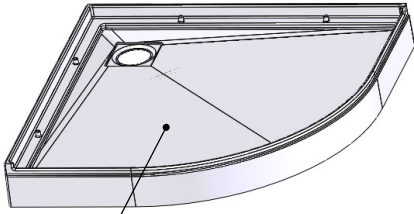

AA

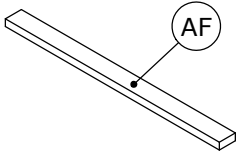

AF

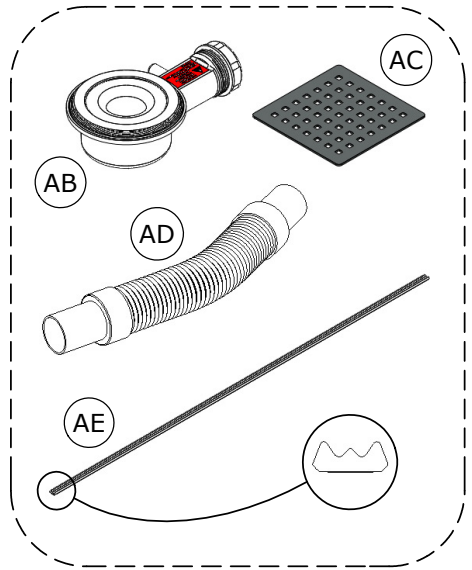

AB

AC

AD

AE

# Colis 2

## S1555-A

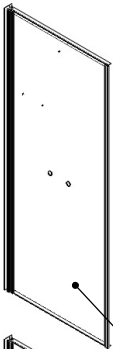

EDEN 2

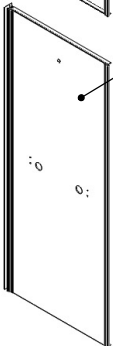

EDEN 2+

BA



BB



BC

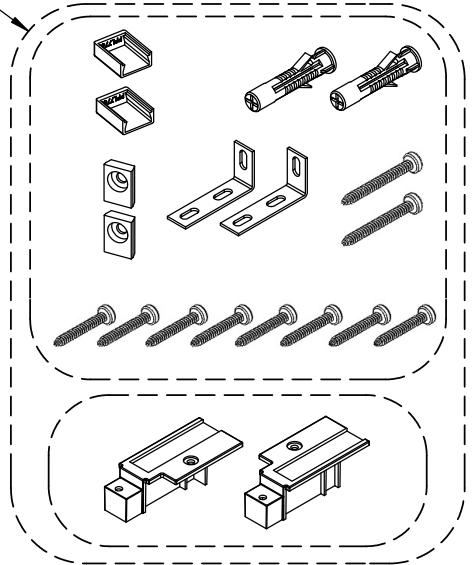

x2

### Colis 3

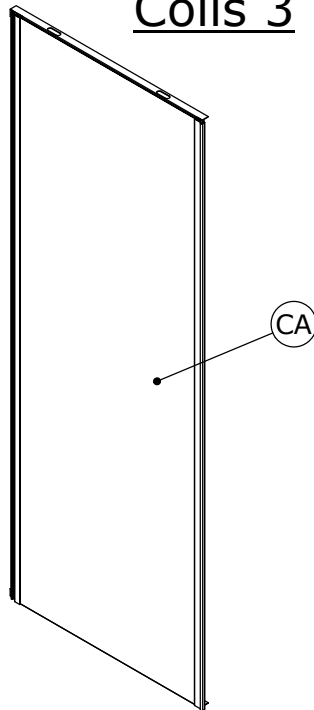

### Colis 4

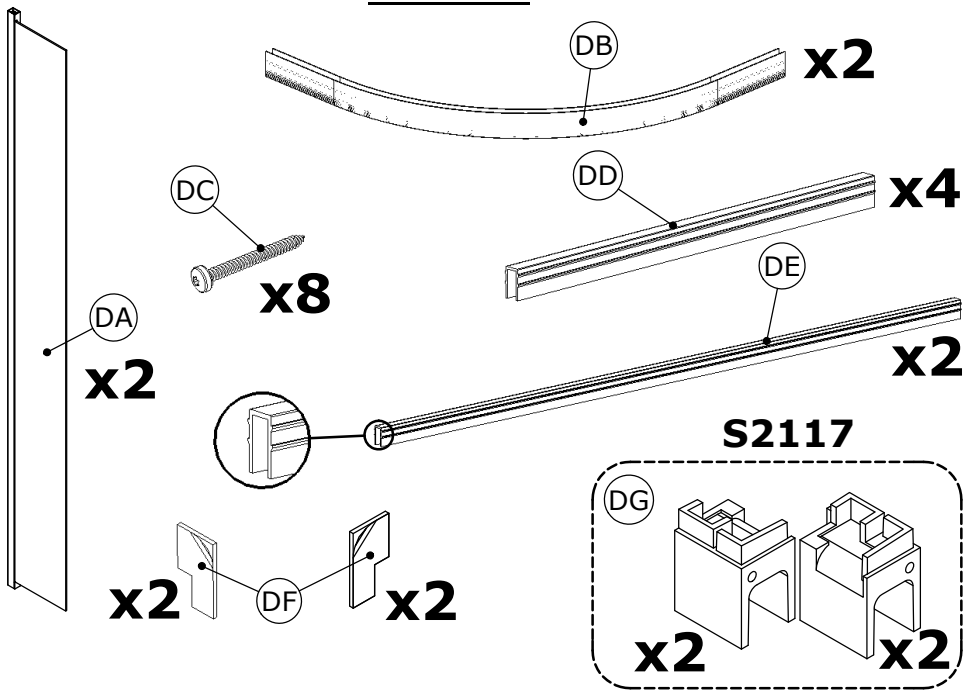

# Colis 5

**S1881**

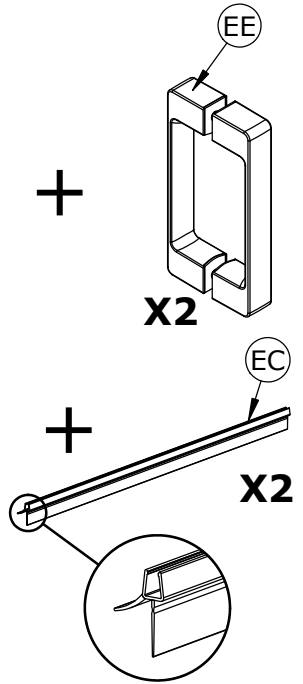
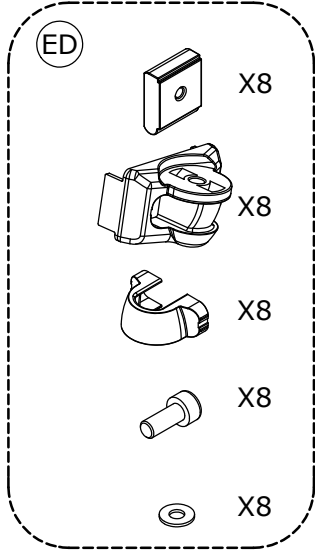
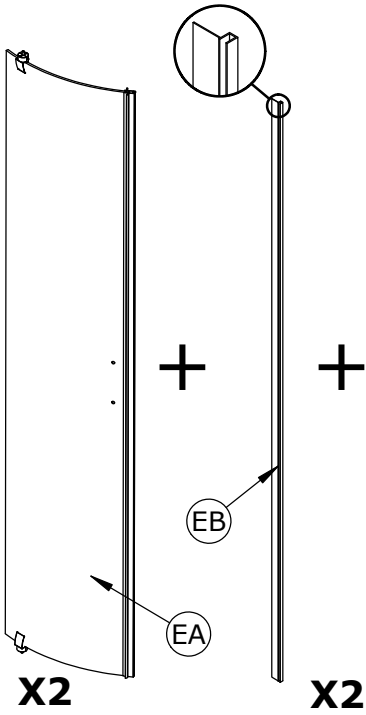

# Boite B1171

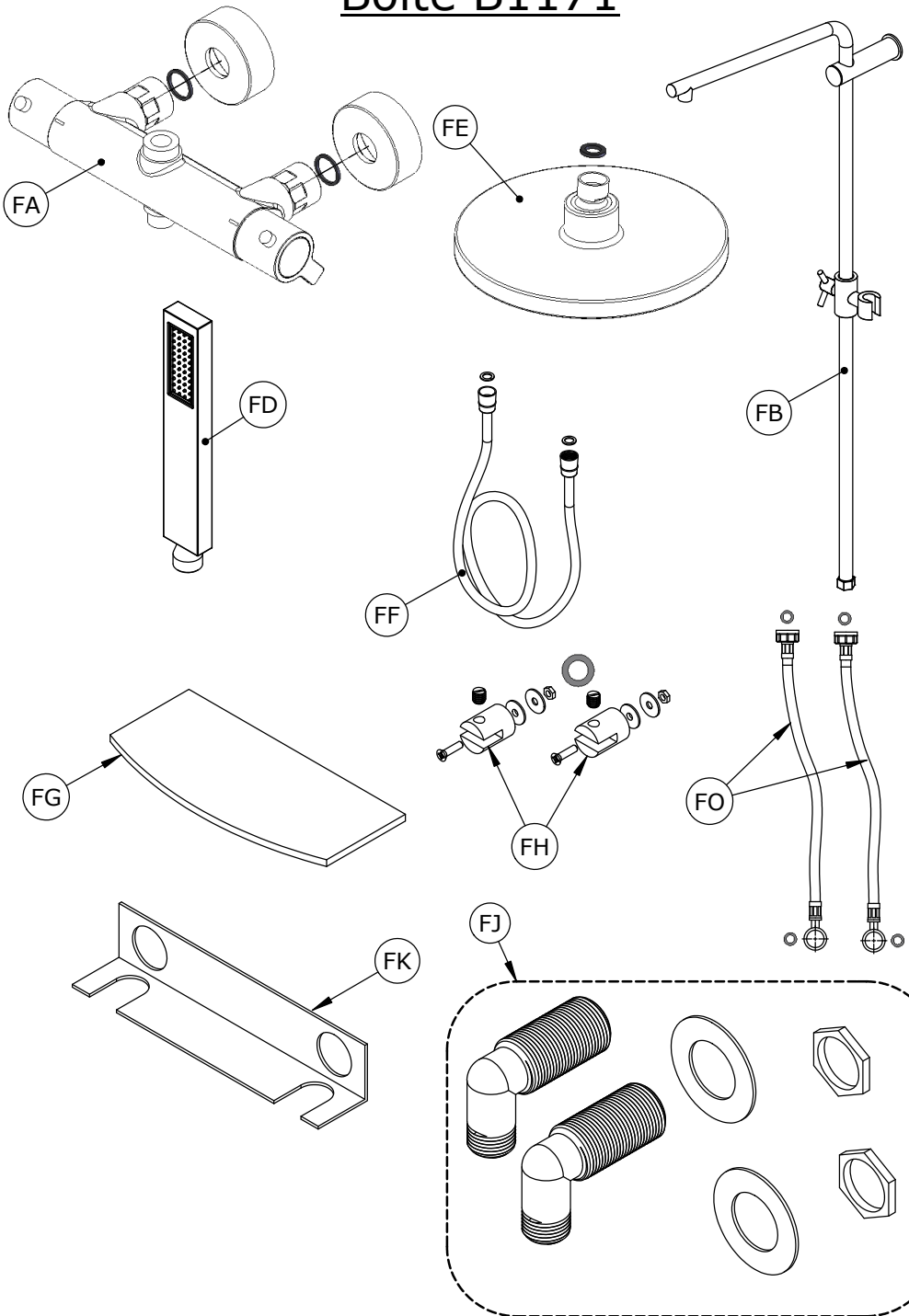

# Boite B1172

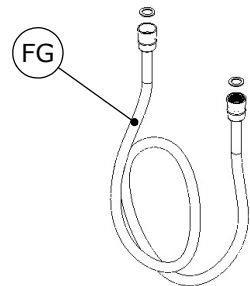
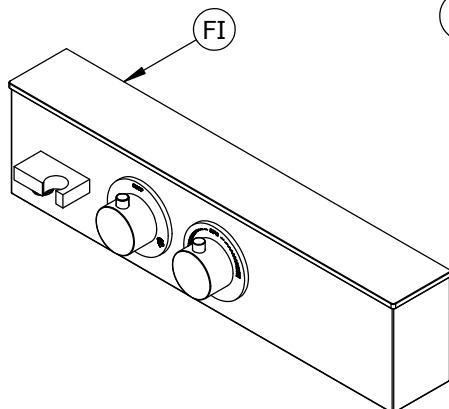
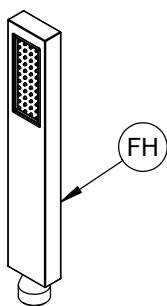
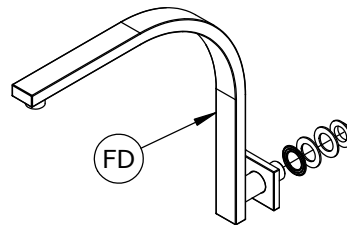
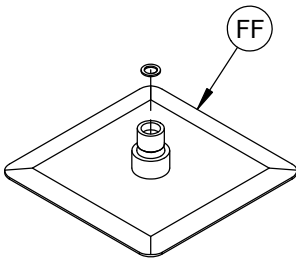
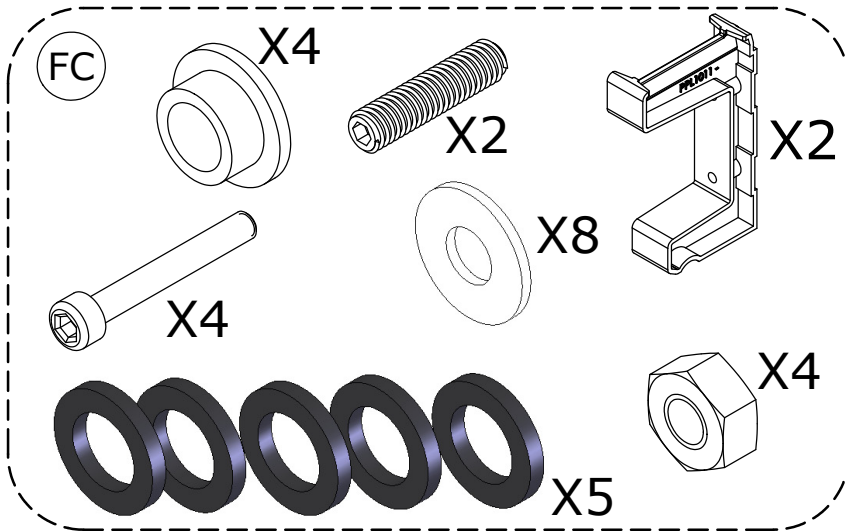

- Matériel nécessaire
- Tools required
- Material necesario
- Materiale necessario
- Nodige gereedschap
- Erforderliche Werkzeuge

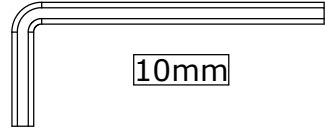
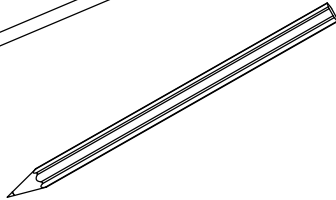
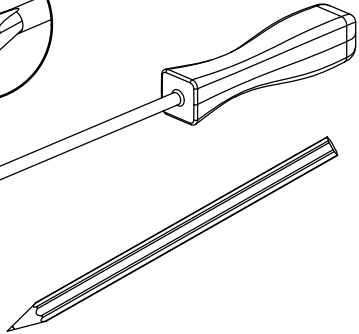
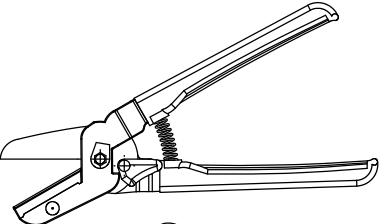
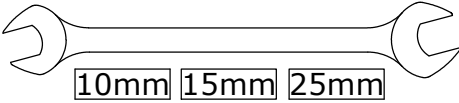
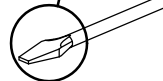
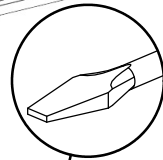
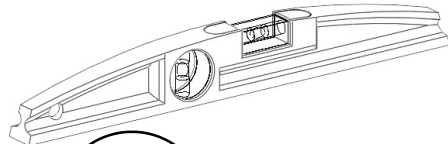

10mm

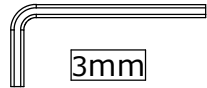

3mm

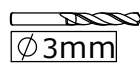
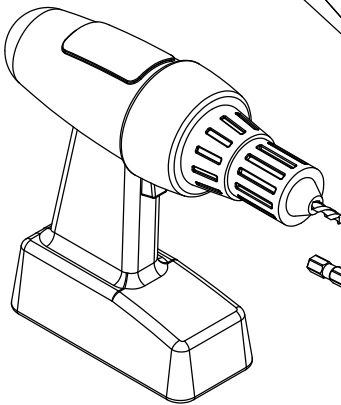
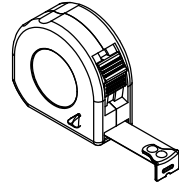
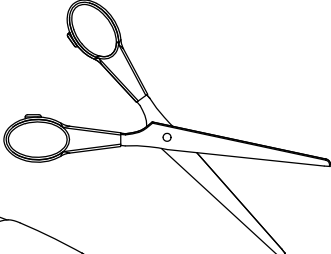

∅3mm



∅6mm

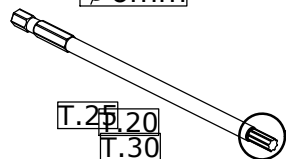

T.25  
T.20  
T.30

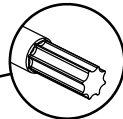

**F** REVERSIBILITE **GB** REVERSIBILITY **E** REVERSIBILIDAD  
**I** REVERSIBILITA **NL** OMKEERBAARHEID **D** WAHLWEISE MONTAGE

- F** MONTAGE A GAUCHE  
**GB** LEFT HAND  
**E** MONTAJE A LA IZQUIERDA  
**I** MONTAGGIO A SINISTRA  
**NL** MONTAGE LINKS  
**D** MONTAGE LINKS

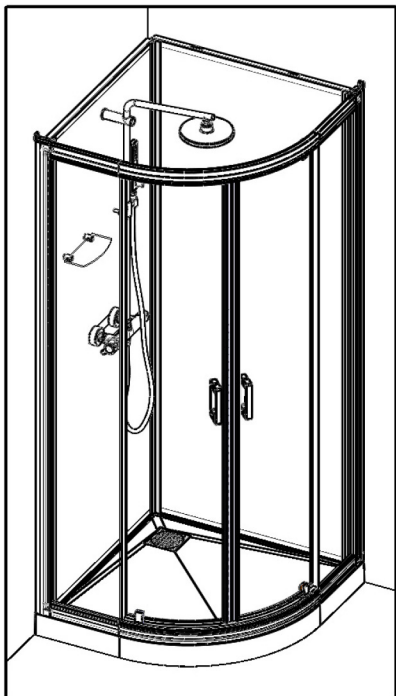

- F** MONTAGE A DROITE  
**GB** RIGHT HAND  
**E** MONTAJE A LA DERECHA  
**I** MONTAGGIO A DESTRA  
**NL** MONTAGE RECHTS  
**D** MONTAGE RECHTS

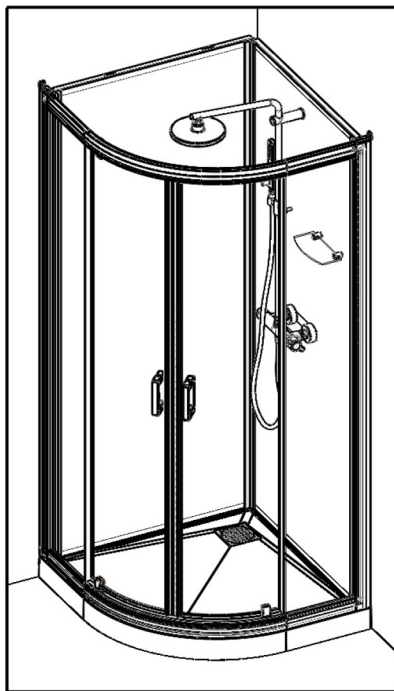

**F** Vous avez la possibilité de réaliser un montage à droite ou un montage à gauche. Notre notice d'installation décrit un montage à gauche. Si vous voulez réaliser un montage à droite, il vous suffit d'inverser le montage.

**GB** This cubicle can be installed either left or right hand. These installation instructions show a left hand installation.

**E** Puede realizar un montaje a la derecha o un montaje a la izquierda. Nuestro folleto de instalación describe un montaje a la izquierda. Si desea montar su cabina a la derecha sólo tendrá que realizar el montaje al contrario.

**I** Avete la possibilità di effettuare il montaggio a destra o a sinistra. Il nostro manuale descrive il montaggio a sinistra. Se volete realizzare il montaggio a destra è sufficiente invertire varie fasi di montaggio.

**NL** U kunt de douchecabine rechts of links monteren. Onze handleiding beschrijft de links montage van de cabine. Keer de montage om als u de cabine rechts wilt monteren.

**D** Sie haben die Möglichkeit, eine Montage auf der linken Seite oder eine Montage auf der rechten Seite durchzuführen. Unsere Montageanleitung beschreibt eine Montage auf der linken Seite. Wenn Sie die Montage lieber auf der rechten Seite durchführen wollen, müssen Sie nur den Montageprozess umkehren.

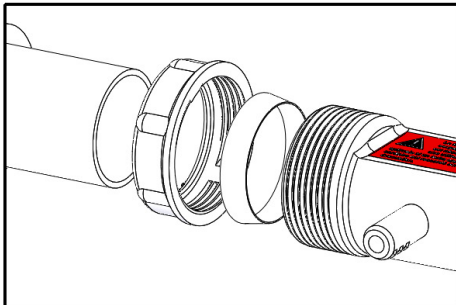
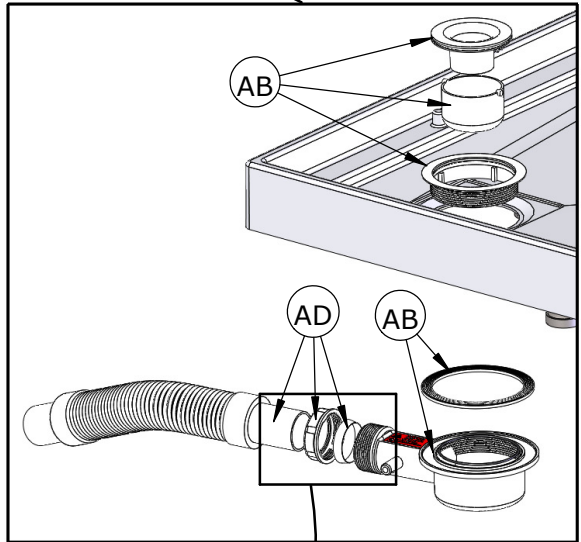
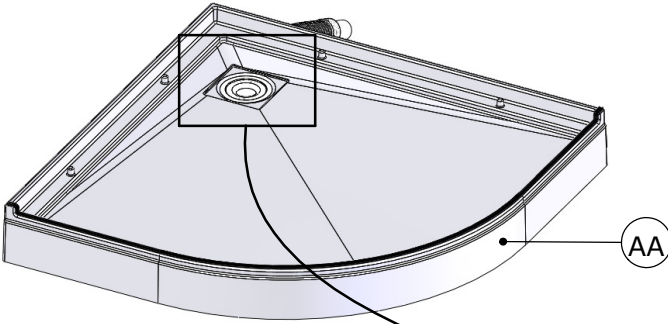



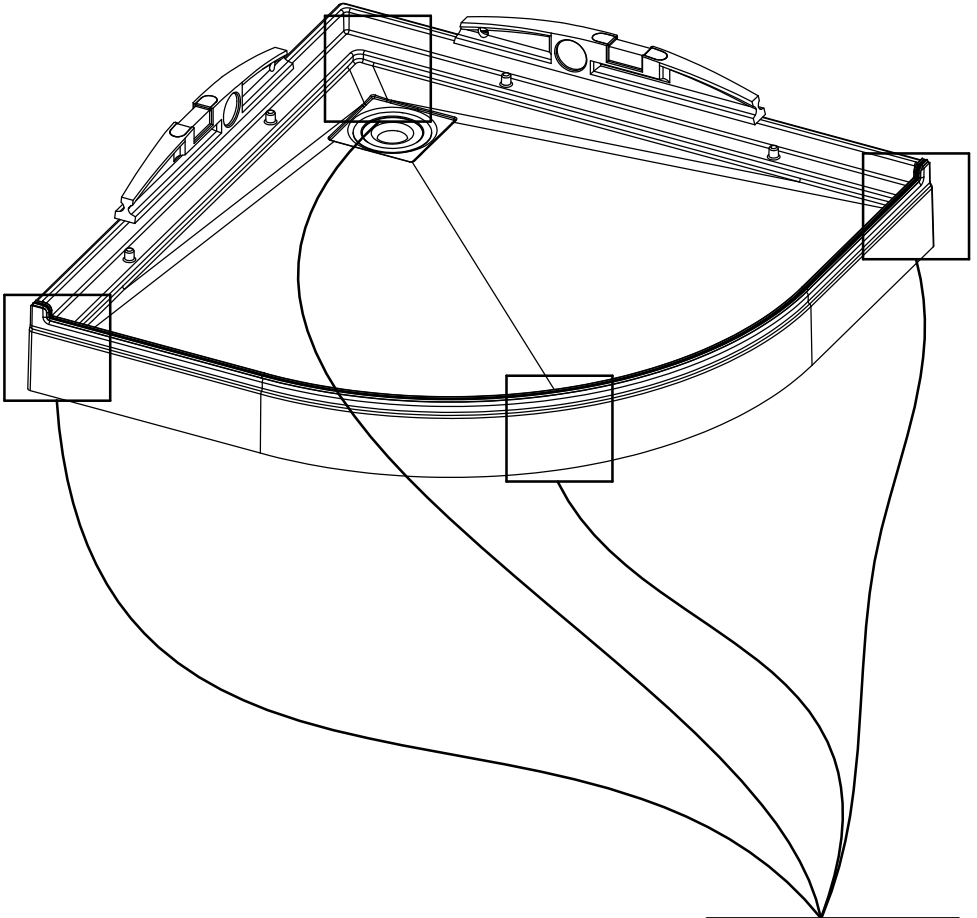

- F Mettre les pieds en contact avec le sol
- GB Feet in contact with the ground
- E Pies en contacto con el suelo
- I Piedi a contatto con il terreno
- NL Voeten in contact met de grond
- D Die sockelfüße im Kontakt mit dem Boden bringen

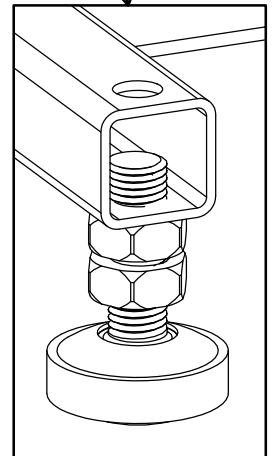

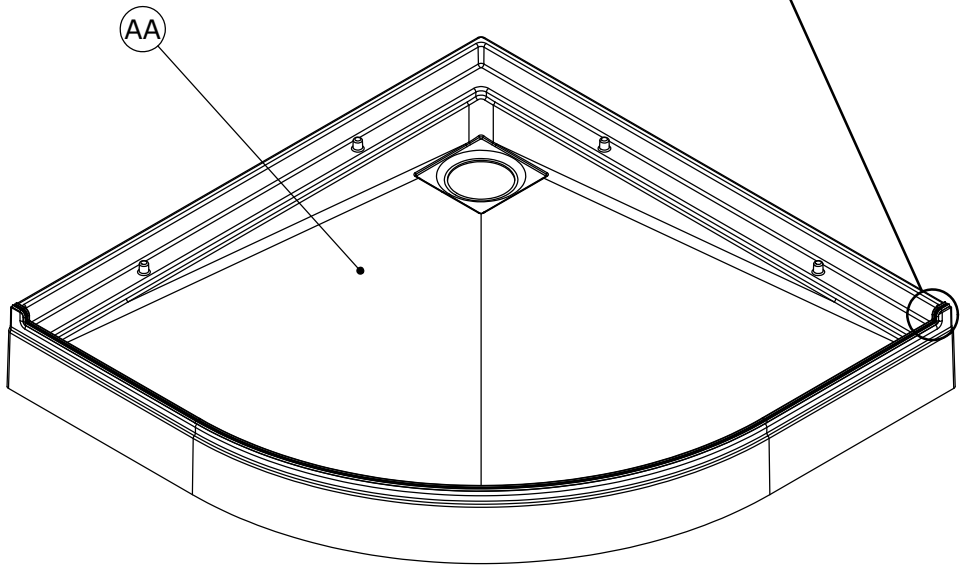
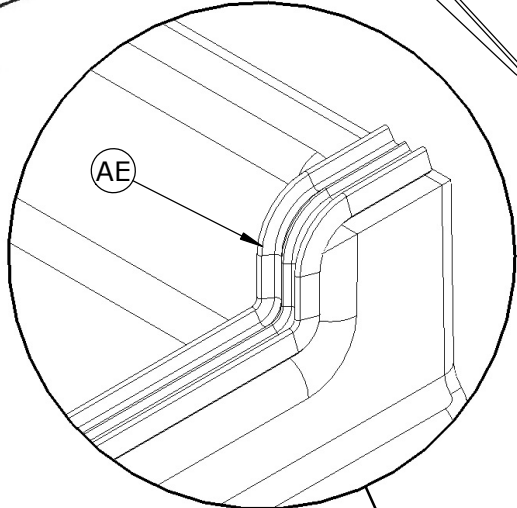
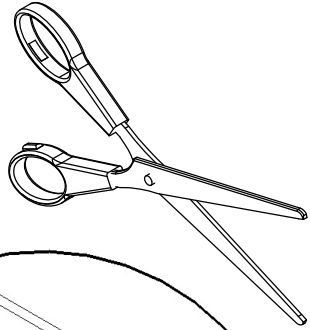
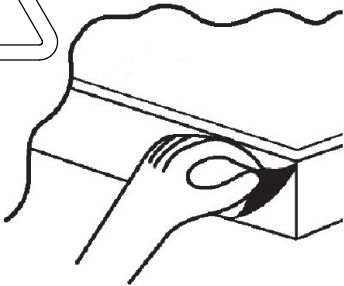

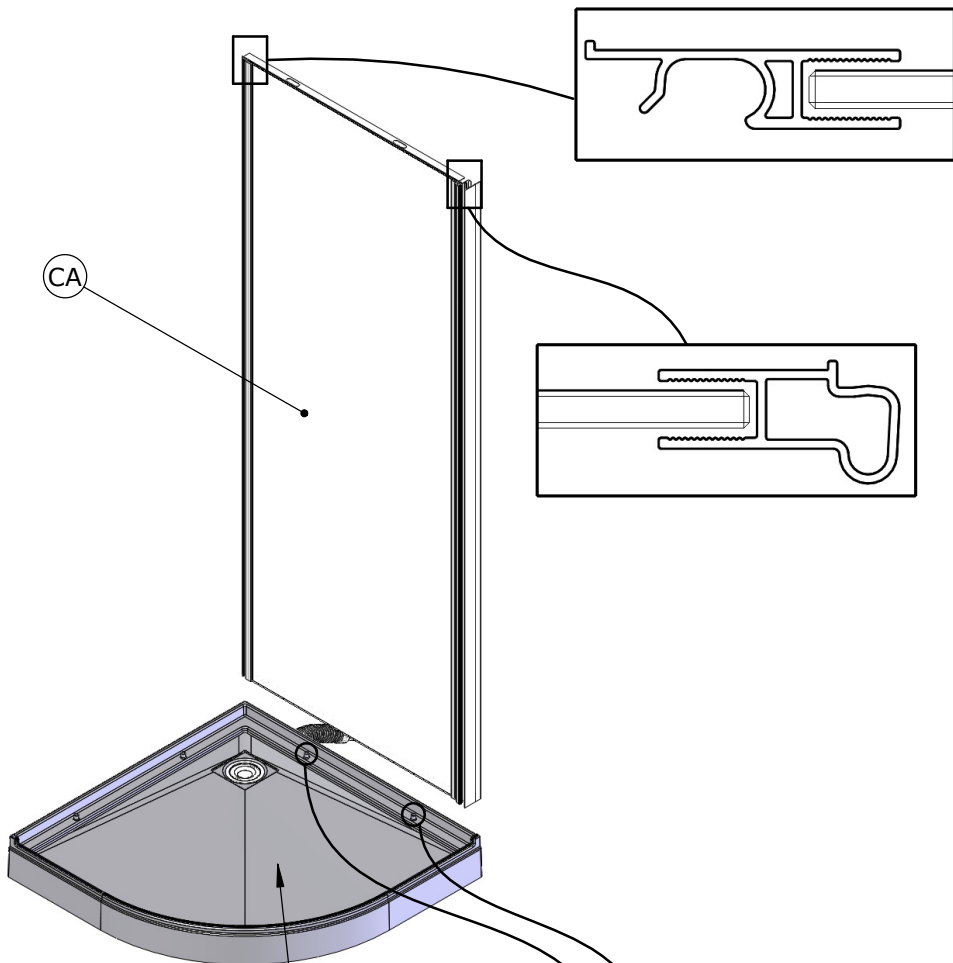

- F Protéger le receveur
- GB Protect the shower tray
- E Proteger el plato
- I Proteggere il piatto
- NL Scherm de douchebak
- D Duschtasse schützen

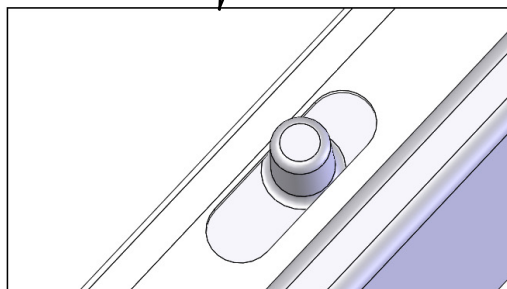

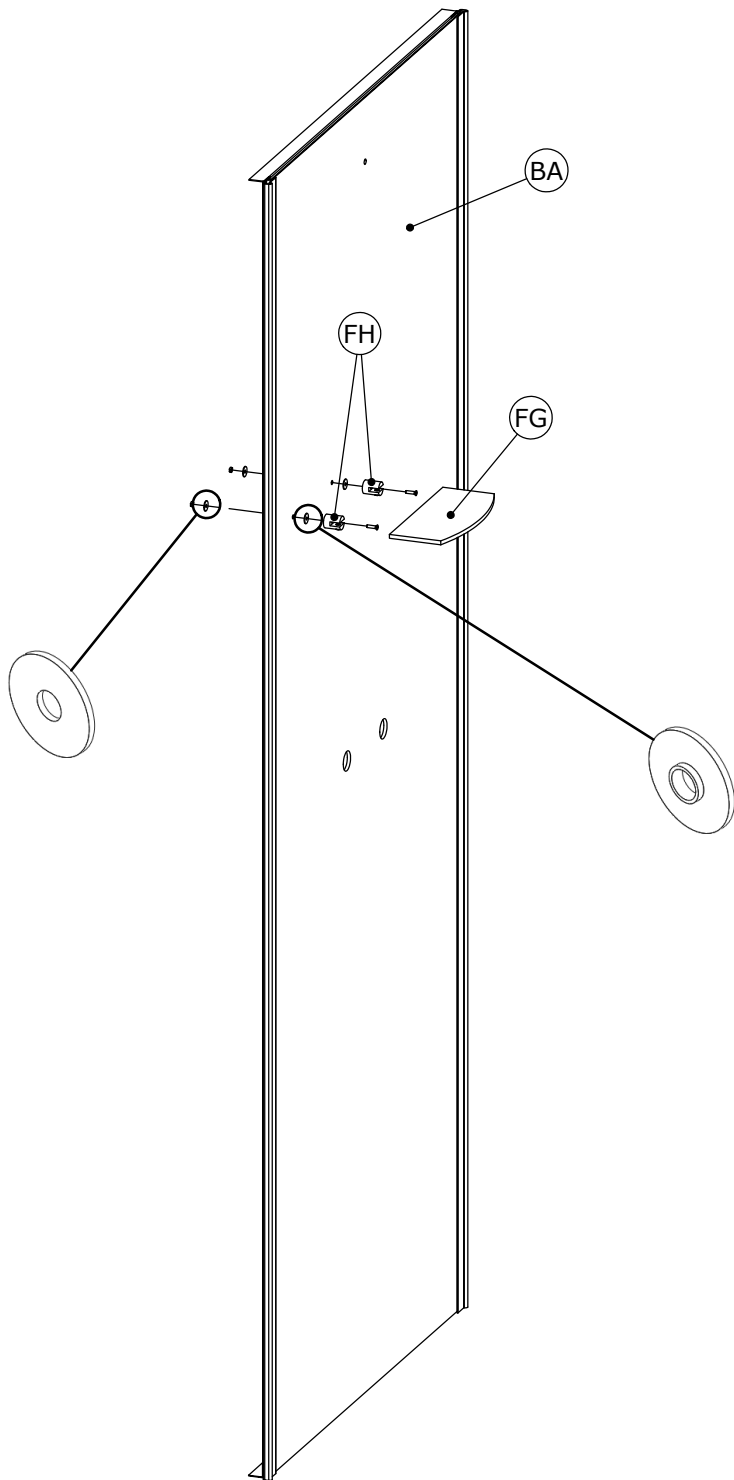

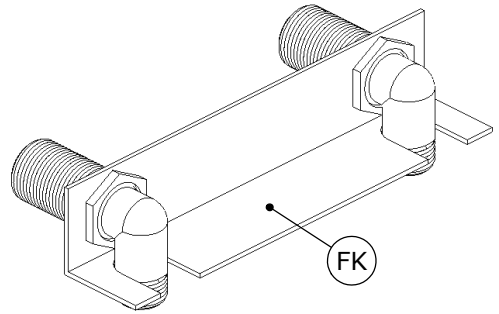
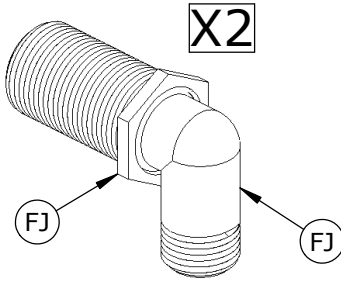

1

2

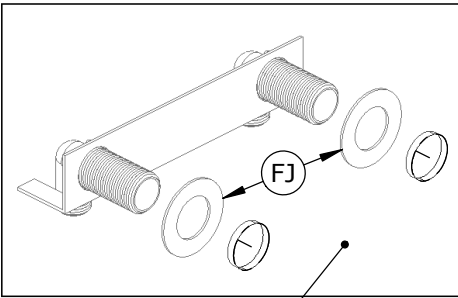

- Intérieur ● Inside
- Interior ● Interno
- Binnenkant ● Innen

3

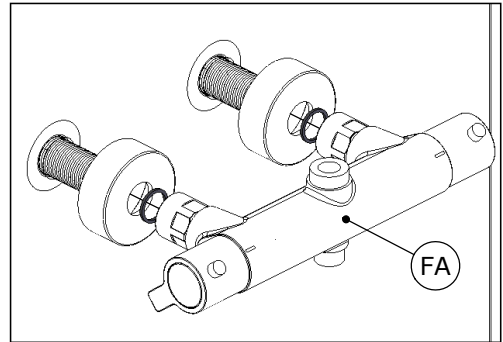

4

- Contact ● Contact ● Contacto
- Contatto ● Contact ● Kontakt

- Serrer ● Tighten ● Apriete
- Serrare ● Aandraaien ● Festziehen

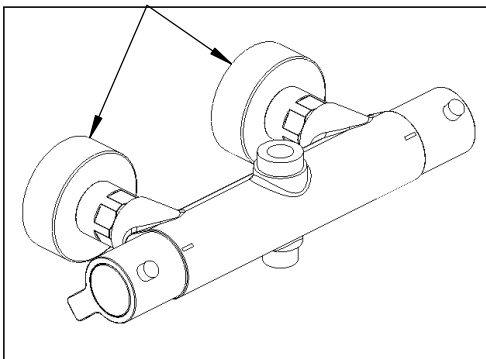

5

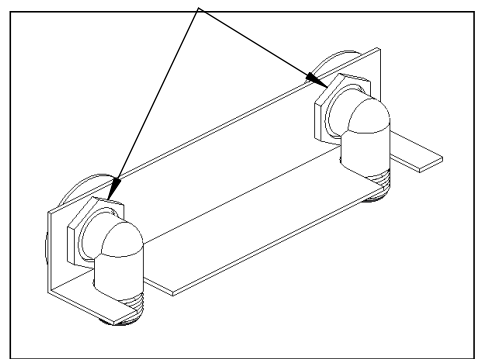

6

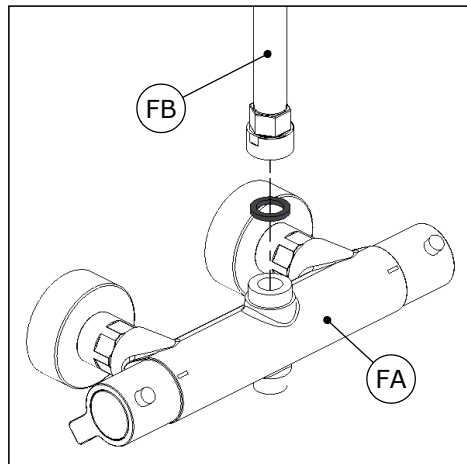
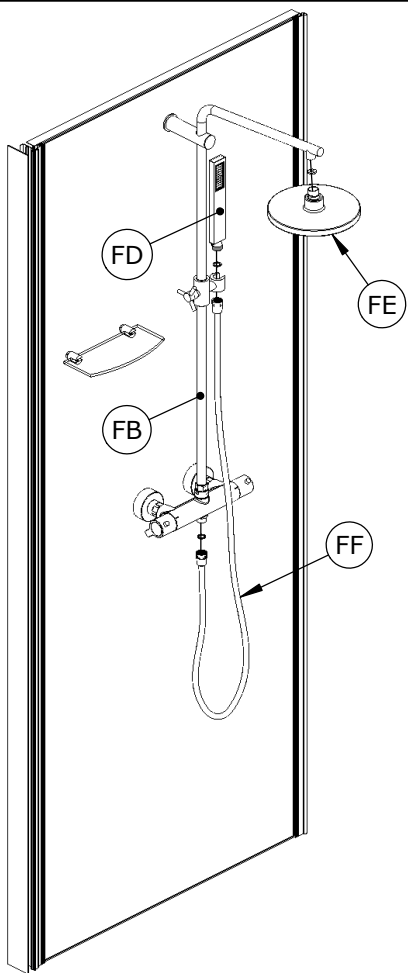

1

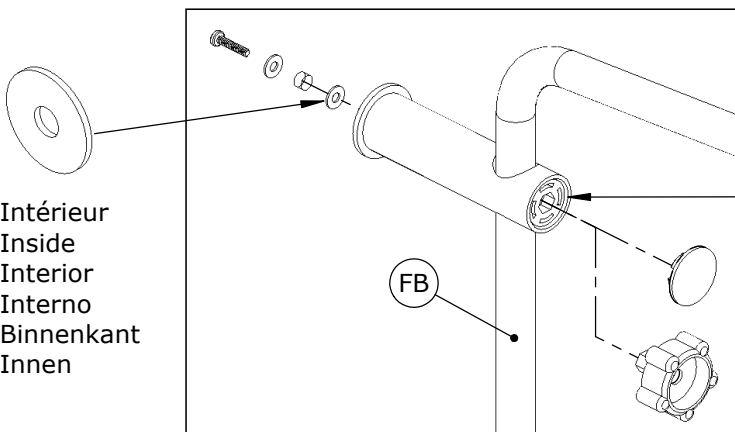

- Intérieur
- Inside
- Interior
- Interno
- Binnenkant
- Innen

- Serrer
- Tighten
- Apriete
- Serrare
- Aandraaien
- Festziehen

2

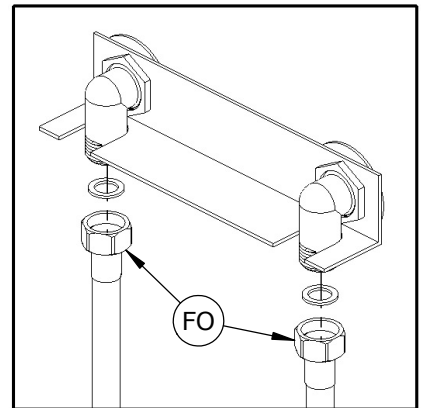
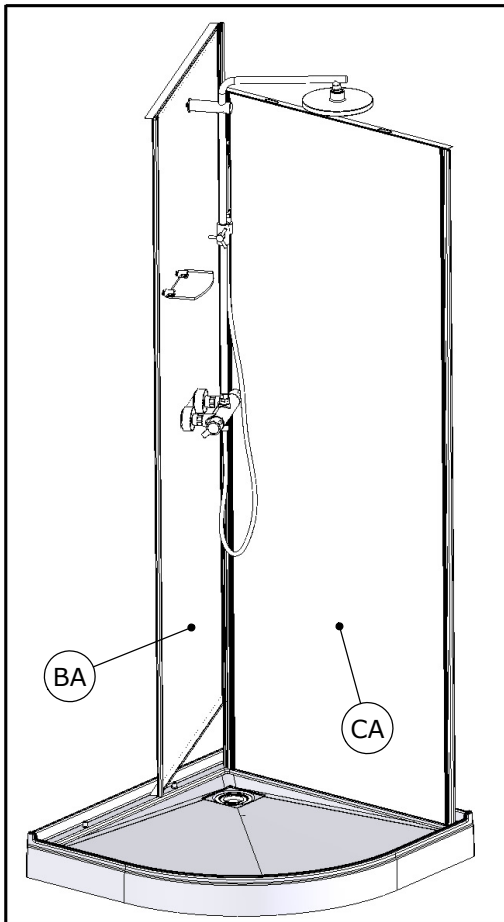
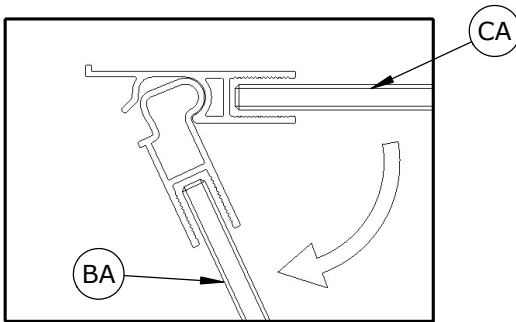

- Vérifier le bon serrage de chaque connexion afin d'éviter tout problème de fuite lors de la mise en eau
- Check that each connection is properly tightened in order to avoid any potential leakage problems when put under pressure
- Comprobar cada conexión sea correcta para evitar los problemas de fuga una vez se conecte con el agua
- Controllare il buon serraggio di tutti i collegamenti allo scopo di evitare perdite d'acqua
- Controleren op waterdichtheid alvorens u de douchecabine definitief plaatst. Hiermee vermijdt u mogelijke lekkages nadat het water op druk wordt aangesloten
- Zur Vermeidung kein Leckproblem bei der Flutung, die gute Klemmen von jeder Verbindung überprüfen

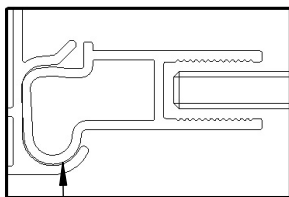

- Intérieur ● Inside
- Interior ● Interno
- Binnenkant ● Innen

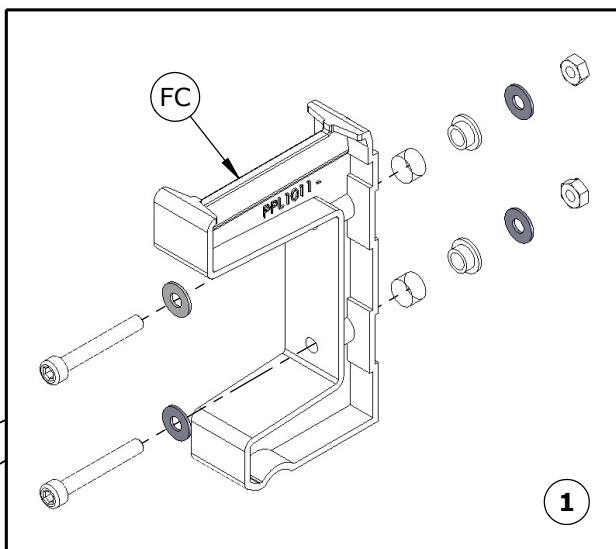

- Passer les flexibles dans les orifices
- Put hoses into holes
- Ponga las mangueras en los agujeros
- Mettere i flessibili nei fori
- Zet de flexibele in de gaten
- Zulaufschläuche durch die vorgesehenen Öffnungen führen

- Flexibles eau chaude/eau froide
- Hoses hot water/cold water
- Mangueras agua caliente/agua fria
- Flessibili acqua calda/acqua fredda
- Flexibele warm water/koud water
- Schlauch Warmwasser/Kaltwasser

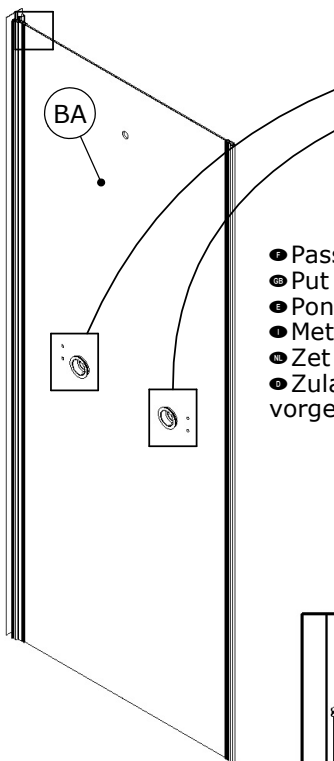

- Flexible de zénithale
- Shower head hose
- Manguera de ducha
- Flessibile doccia
- Flexibele douchekop
- Dusche kopf schlauch

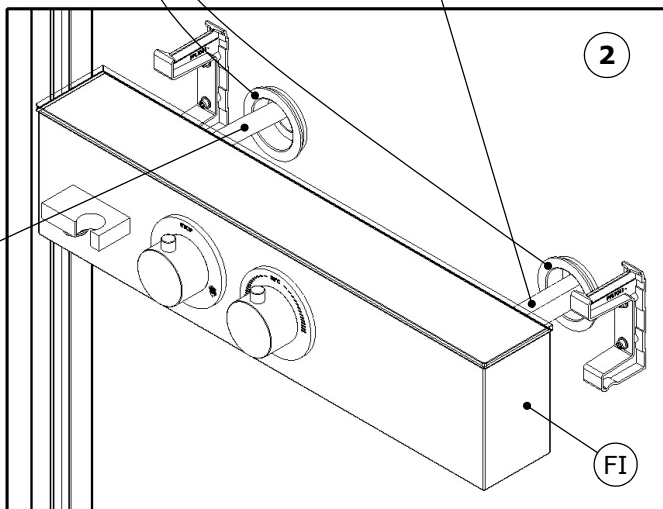



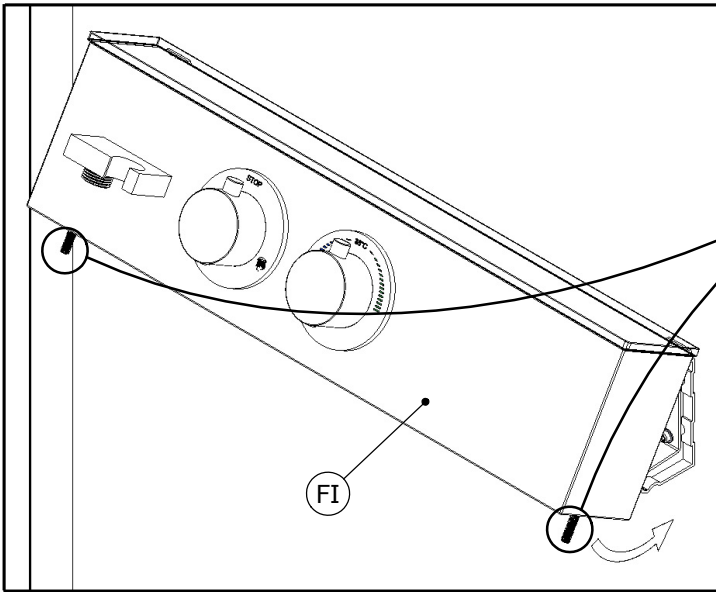

- Serrer jusqu'à affleurement
- Tighten until flush
- Apriete hasta ras
- Serrare a filo
- Draai tot flush
- Festziehen bis bündig

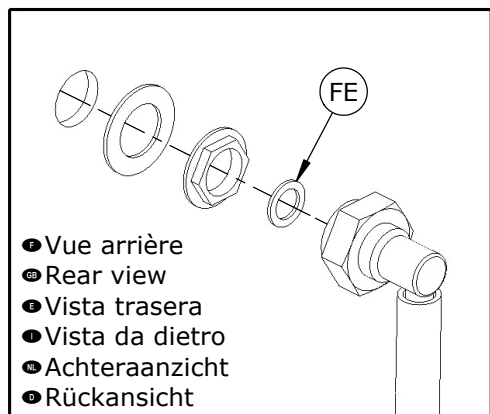
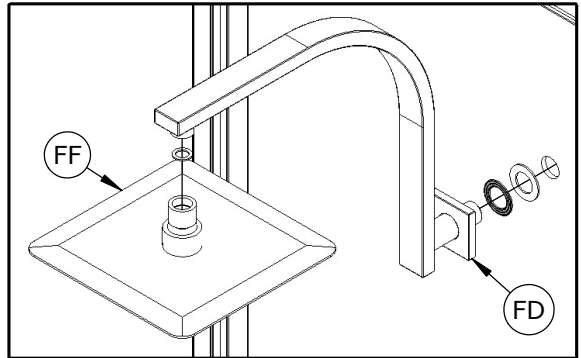
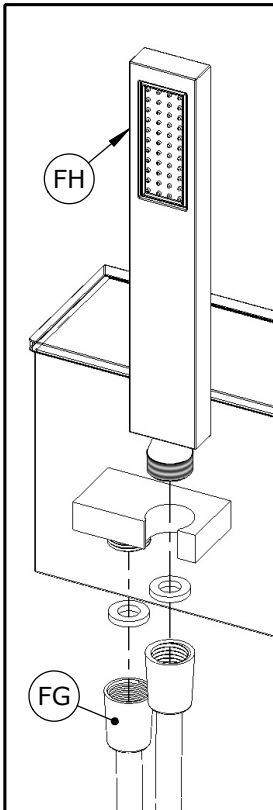

- Vue arrière
- Rear view
- Vista trasera
- Vista da dietro
- Achteraanzicht
- Rückansicht

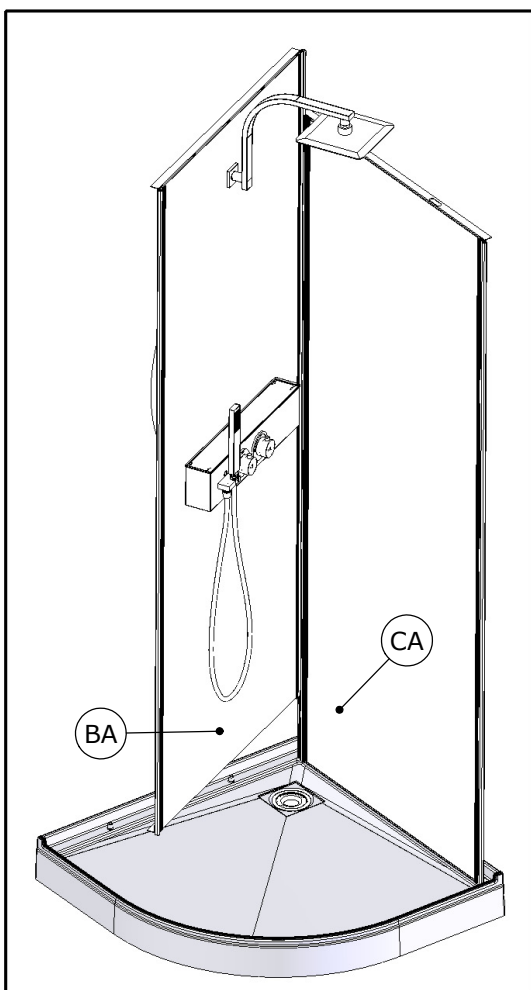
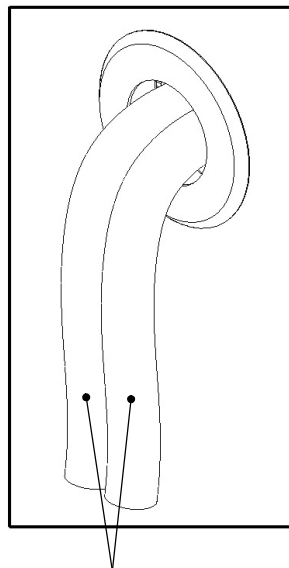
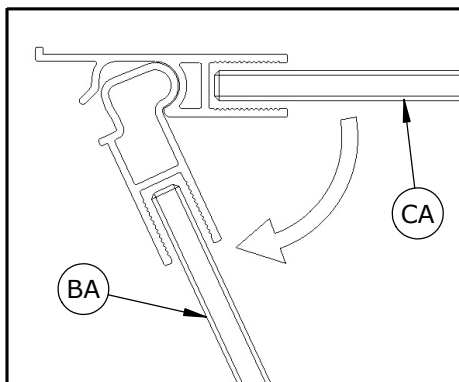

- Raccorder vos flexibles d'alimentation à votre système
- Connect the hoses water to your system
- Conecte el agua mangueras a su sistema
- Collegare i flessibili di acqua al vostro sistema
- Sluit de slangen watervoorziening aan uw systeem
- Zulaufschläuche an System anschließen

- Vérifier le bon serrage de chaque connexion afin d'éviter tout problème de fuite lors de la mise en eau
- Check that each connection is properly tightened in order to avoid any potential leakage problems when put under pressure
- Comprobar cada conexión sea correcta para evitar los problemas de fuga una vez se conecte con el agua
- Controllare il buon serraggio di tutti i collegamenti allo scopo di evitare perdite d'acqua
- Controleren op waterdichtheid alvorens u de douchecabine definitief plaatst. Hiermee vermijdt u mogelijke lekkages nadat het water op druk wordt aangesloten
- Zur Vermeidung kein Leck problem bei der Flutung, die gute klemmen von jede Verbindung überprüfen

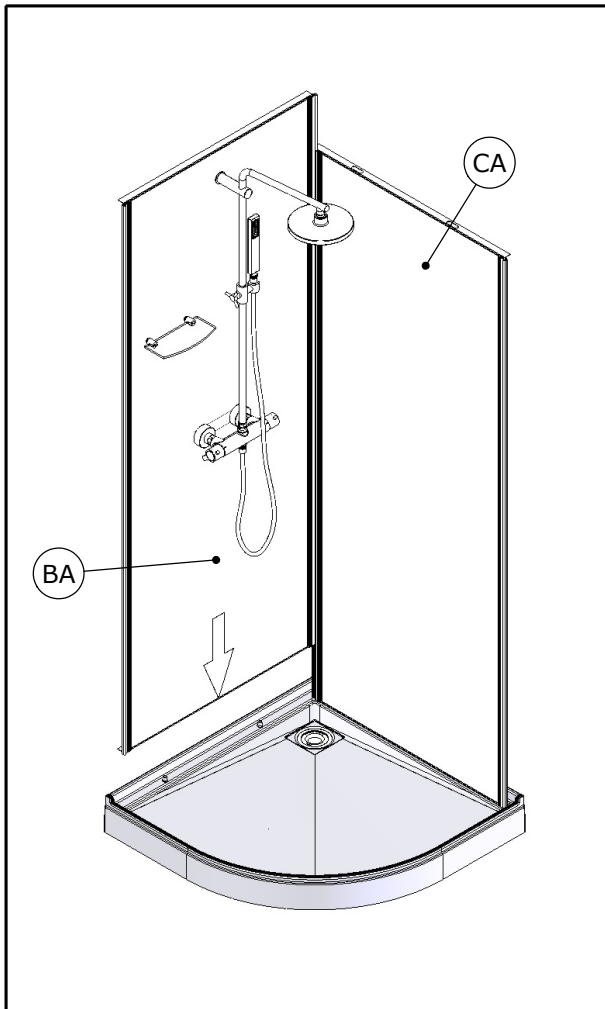
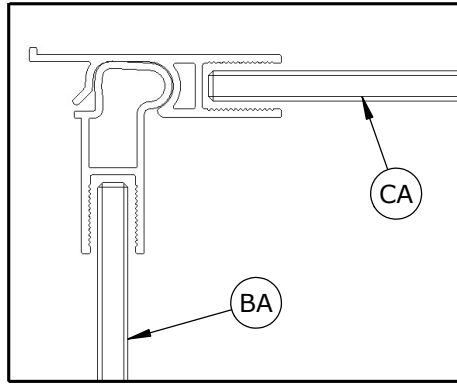

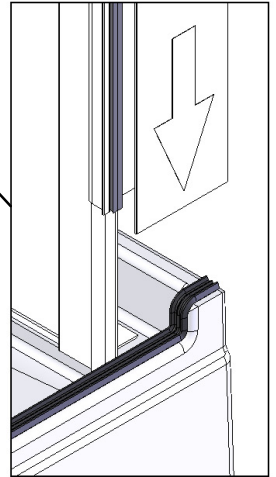
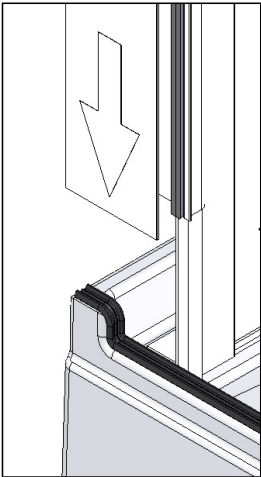
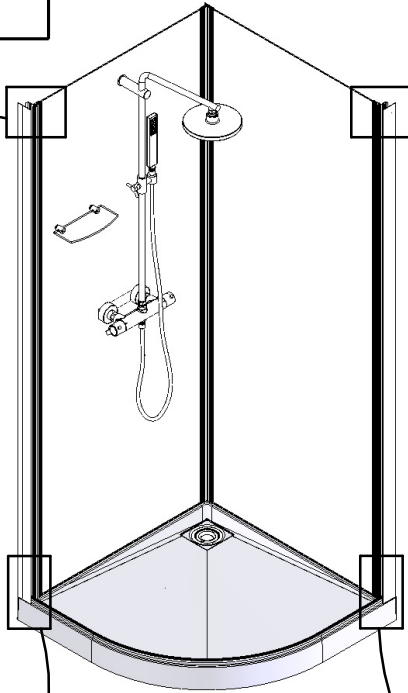
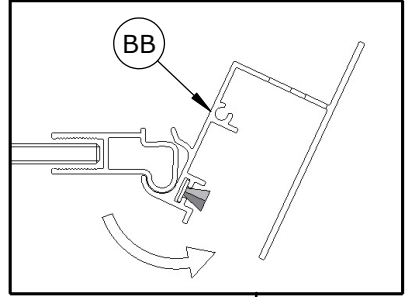
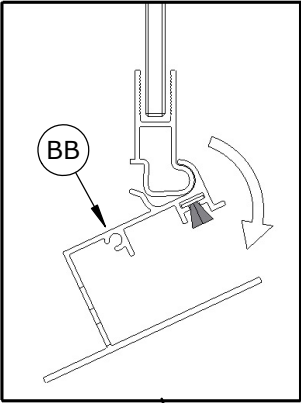

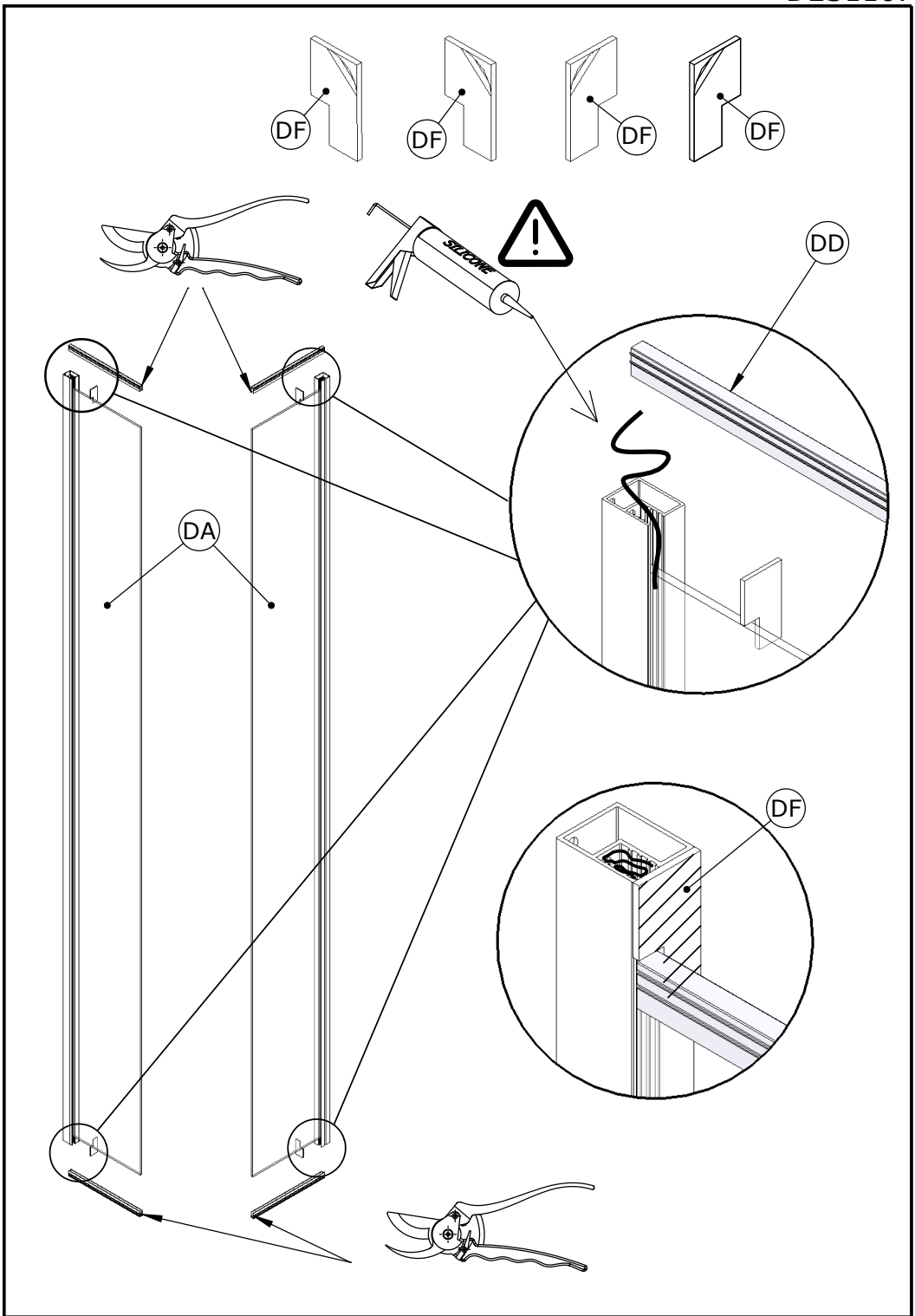

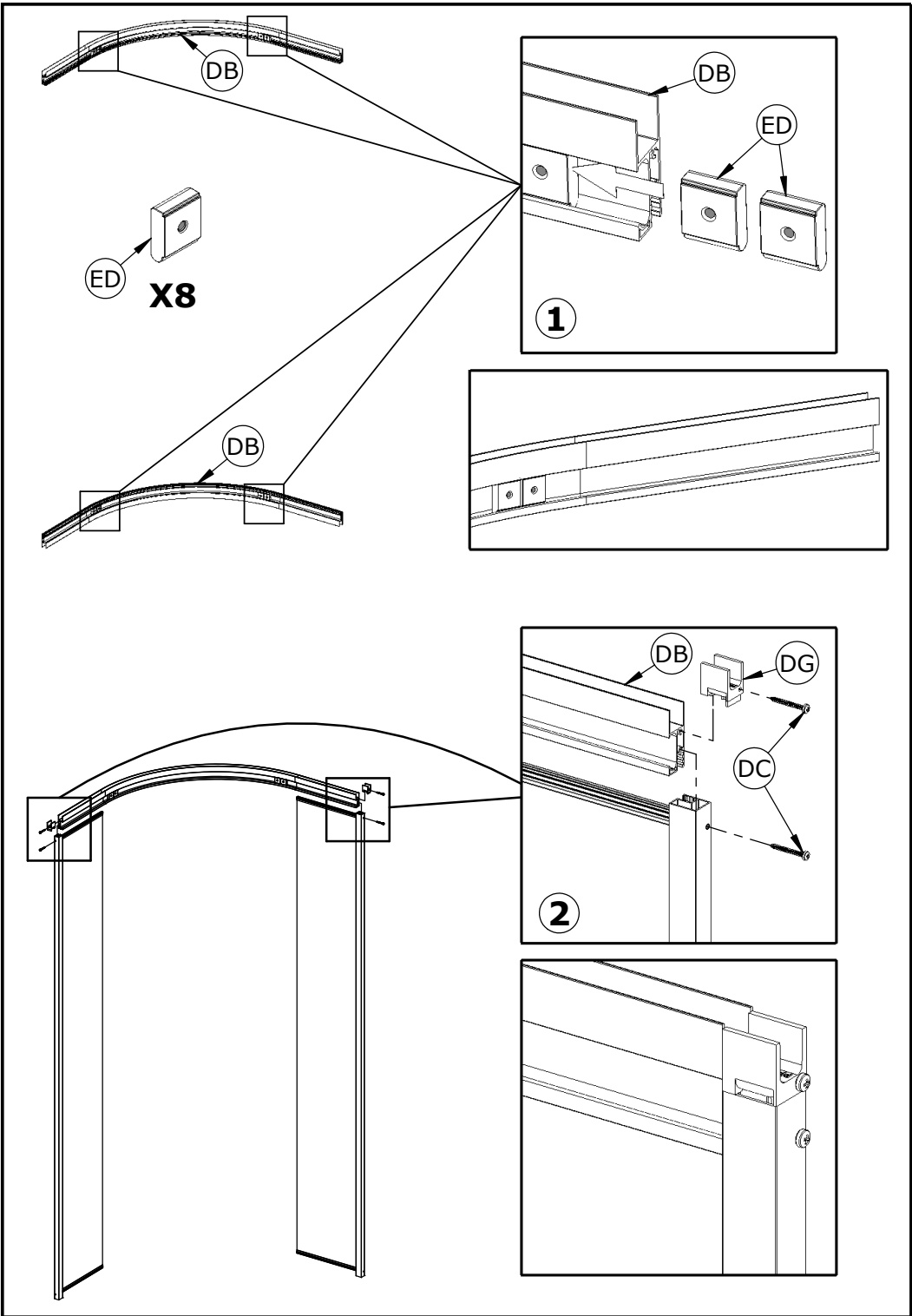

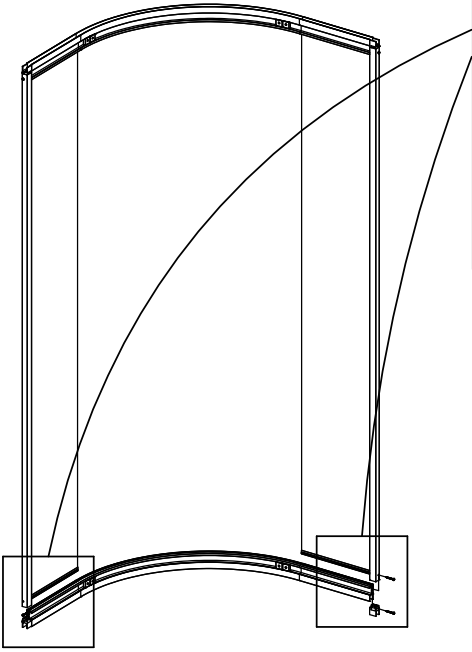
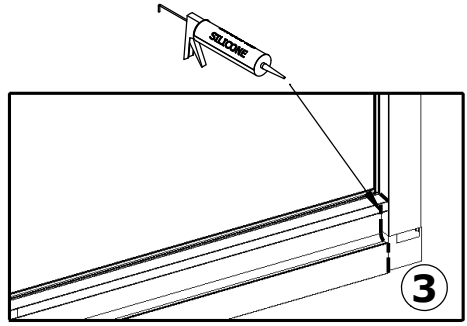
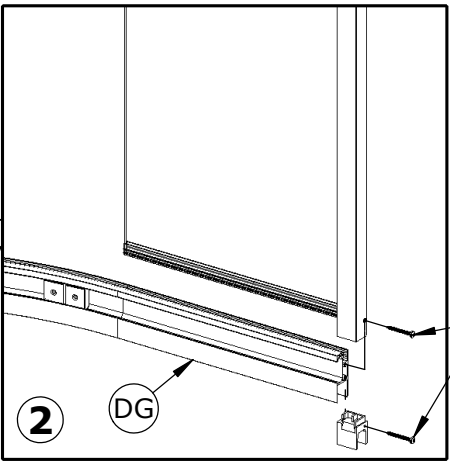
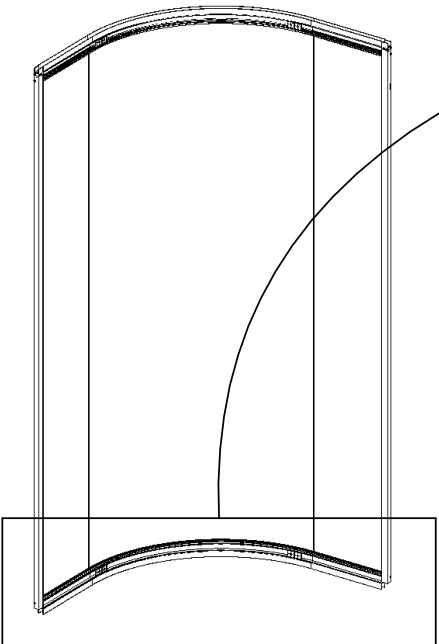
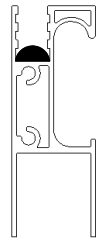
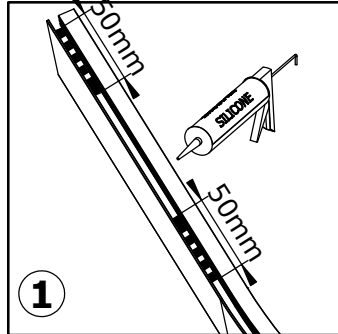
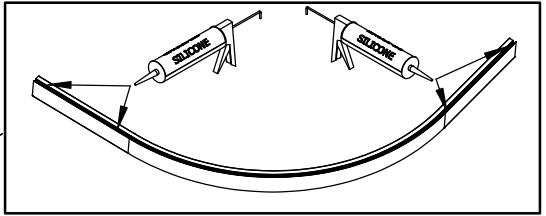

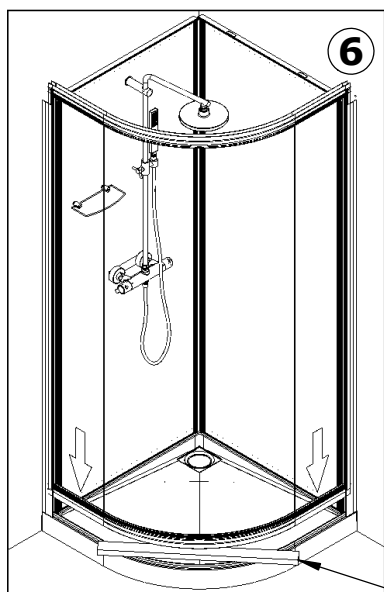
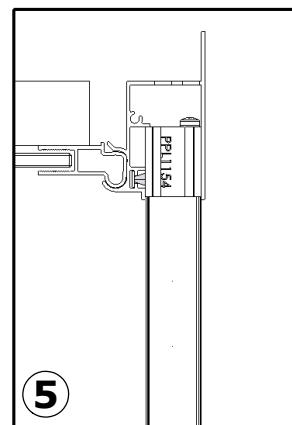
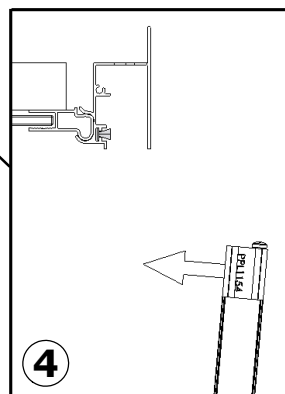
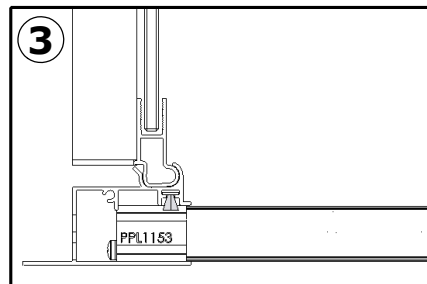
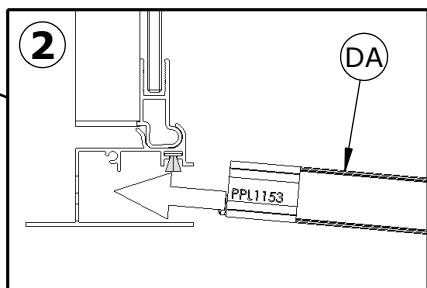
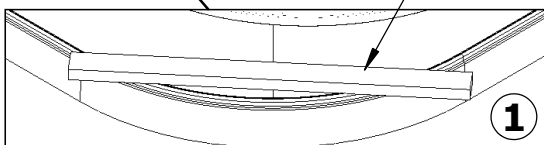
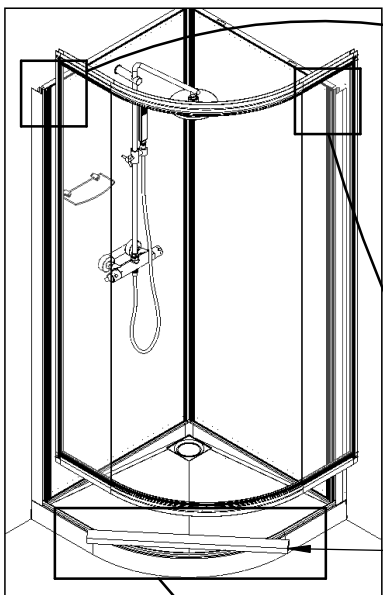

- Retirer (AF)
- Remove (AF)
- Quitar (AF)
- Togliere (AF)
- Verwijderen (AF)
- Entfernen (AF)



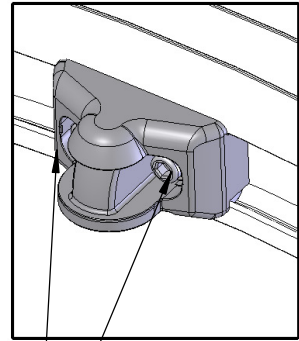
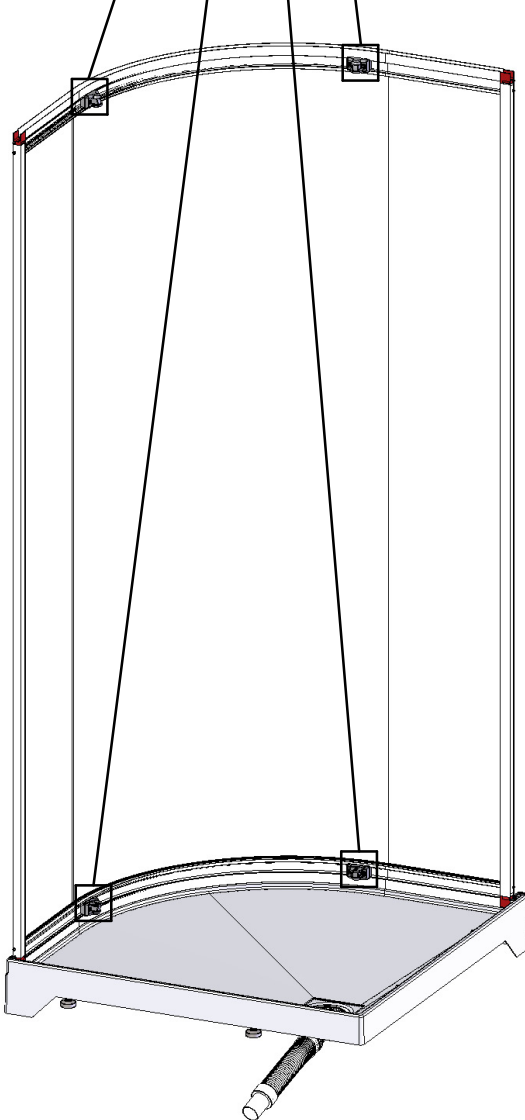
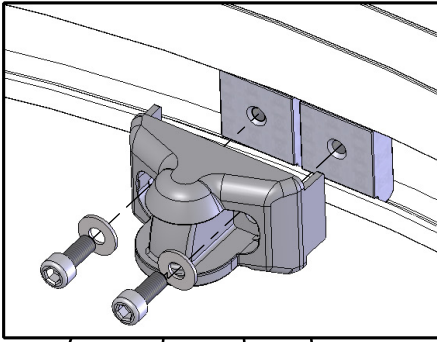

- F Ne pas serrer
- GB Do not overtighten
- E No apriete
- I Non serrare
- NL Niet vastschroeven
- D Nicht festziehen

**UP L**

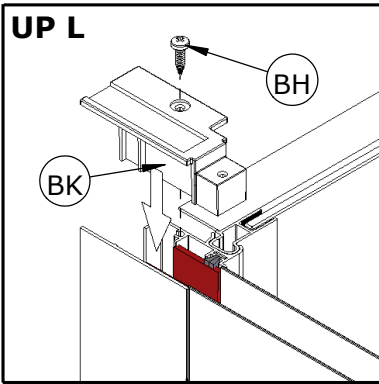

**UP R**

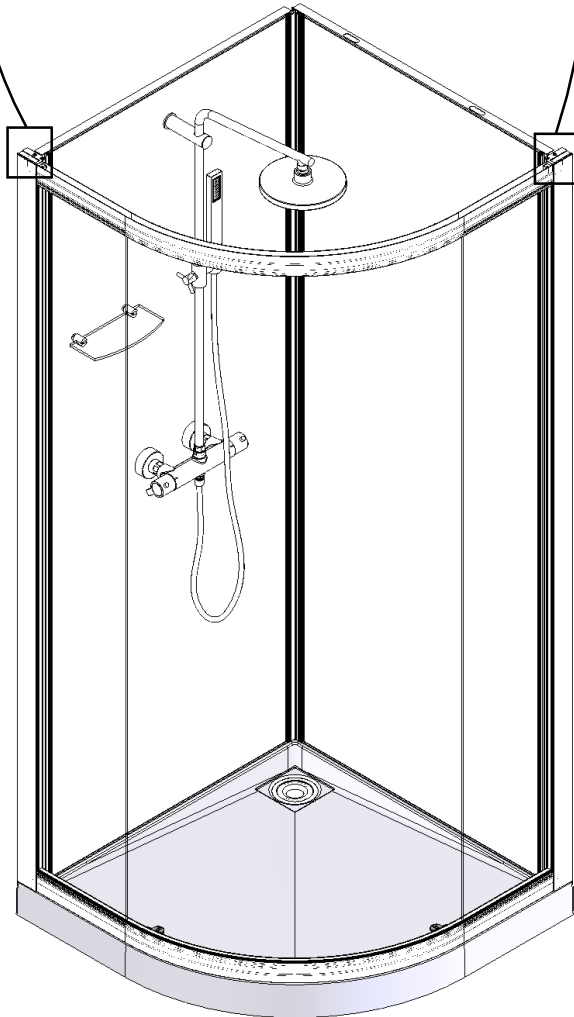
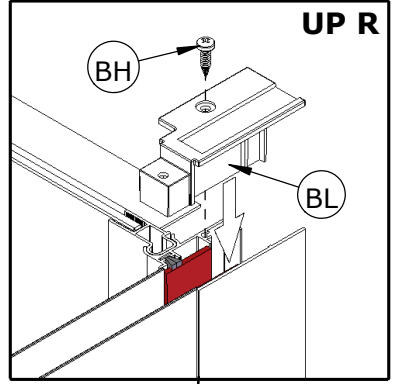

- |      |                    |      |                   |
|------|--------------------|------|-------------------|
| ● F  | Extérieur          | ● F  | Intérieur         |
| ● GB | Outside / Exterior | ● GB | Inside / Interior |
| ● E  | Externo            | ● E  | Interno           |
| ● I  | Esterno            | ● I  | Interno           |
| ● NL | Buitenzijde        | ● NL | Binnenzijde       |
| ● D  | Außen              | ● D  | Innen             |

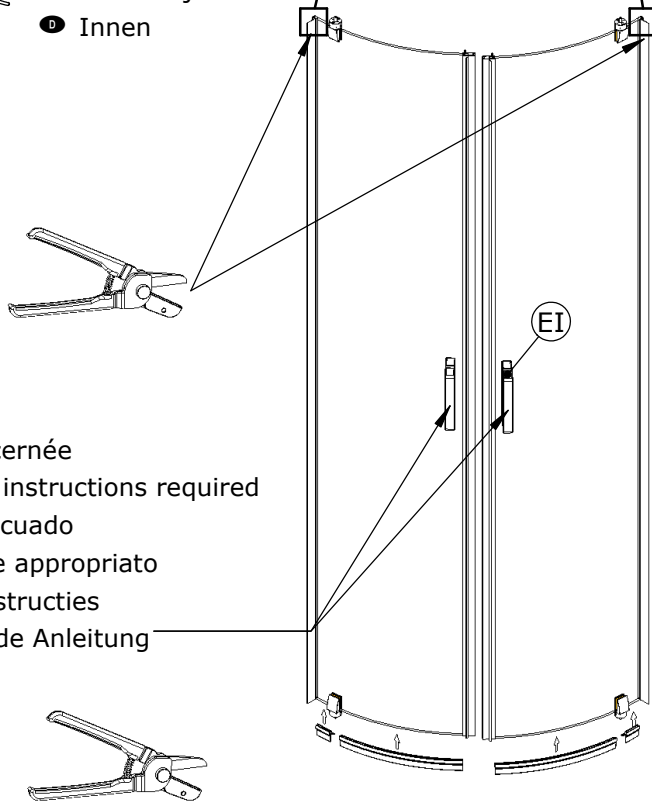
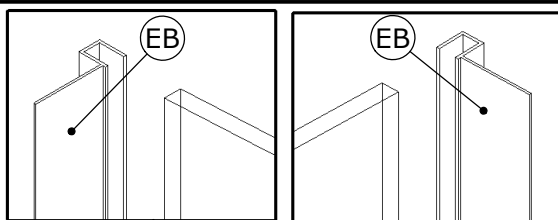
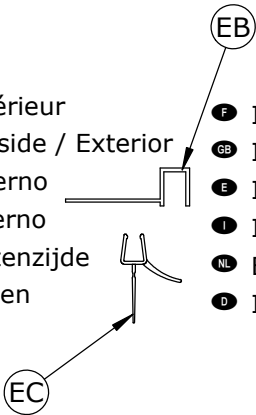

- |      |  |
|------|--|
| ● F  | Voir notice concernée                  |
| ● GB | See installation instructions required |
| ● E  | Ver manual adecuado                    |
| ● I  | Vedere manuale appropriato             |
| ● NL | Zie montage-instructies                |
| ● D  | Siehe betreffende Anleitung            |

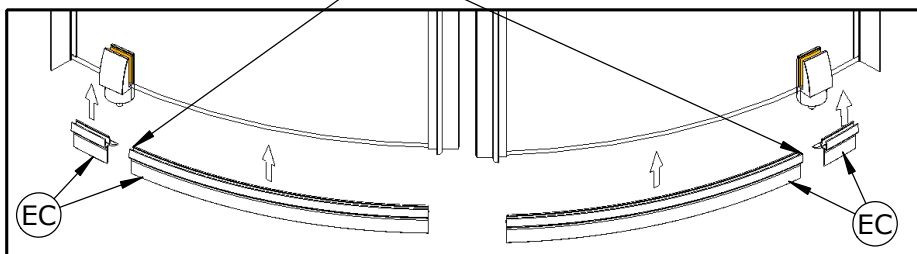

2

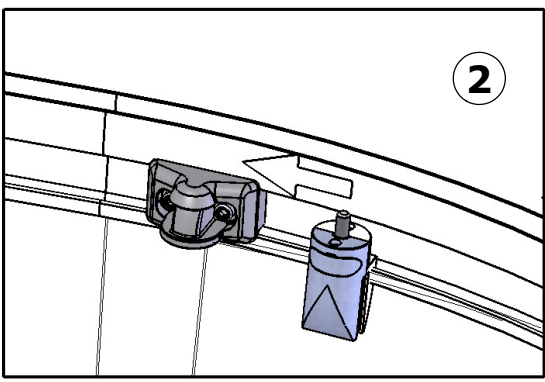

1

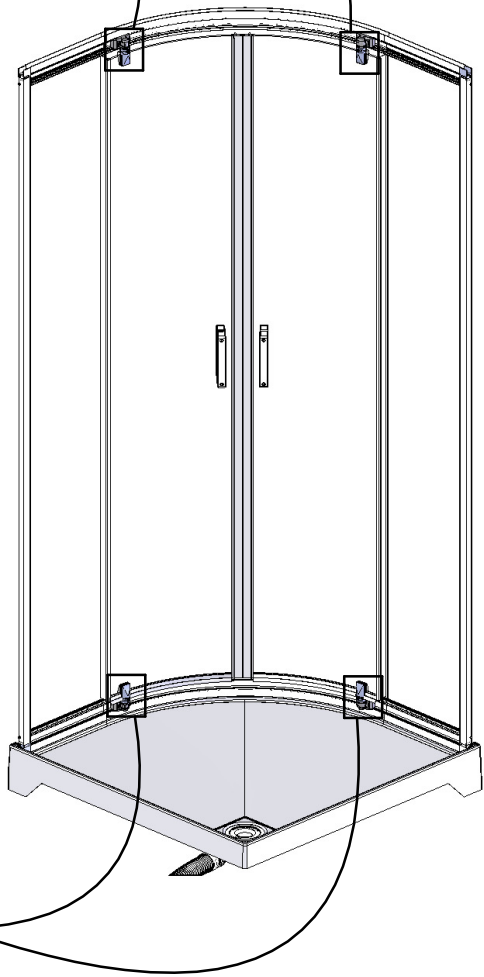
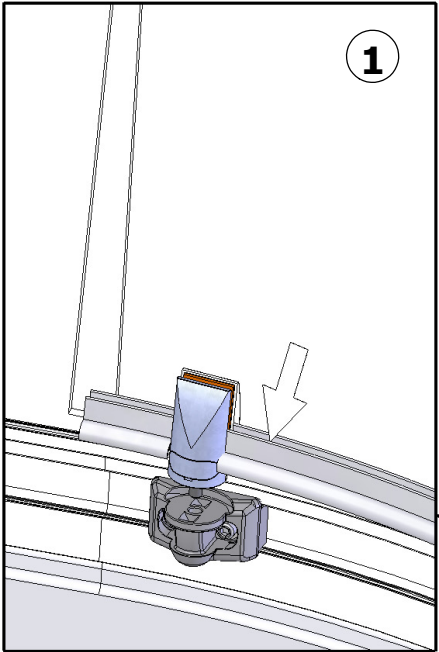

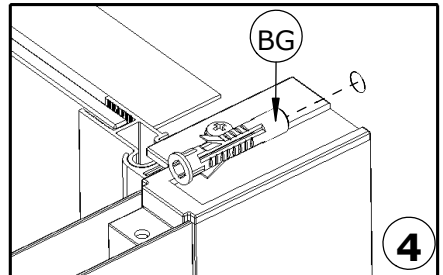
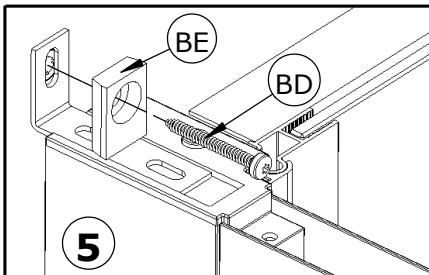
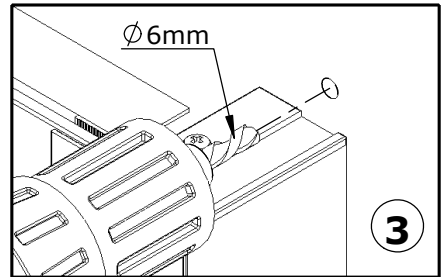
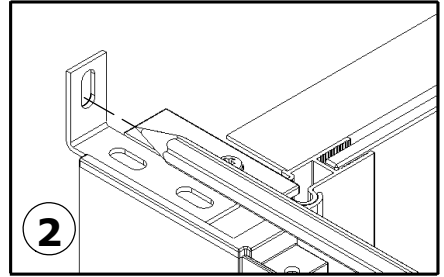
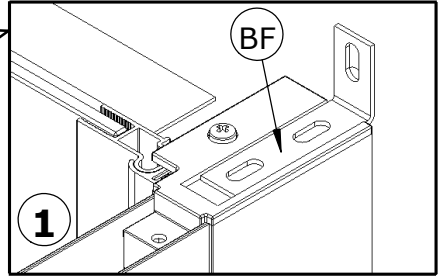
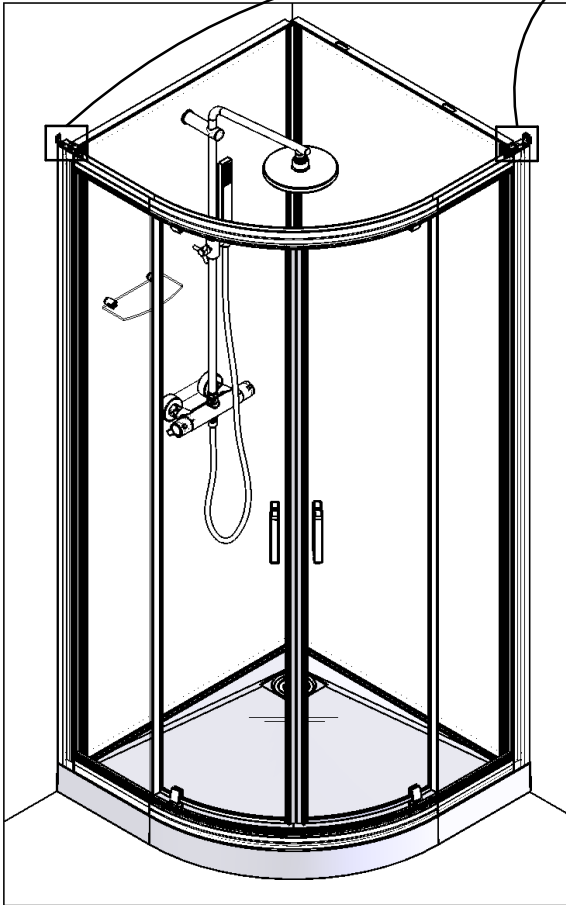

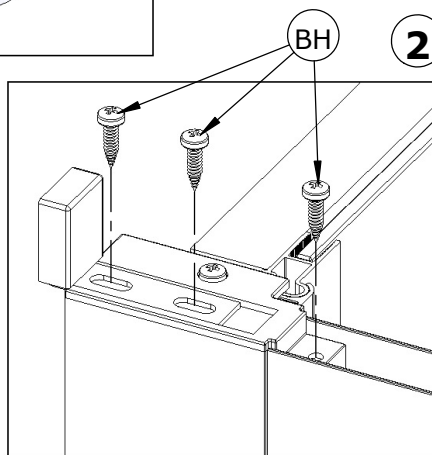
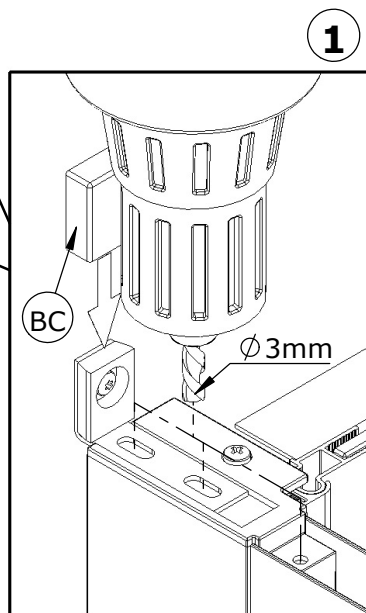
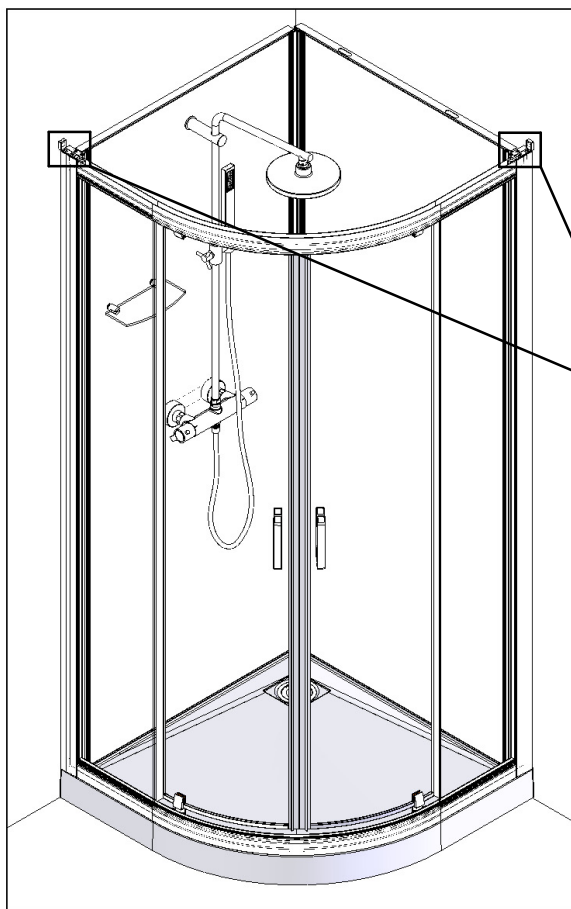

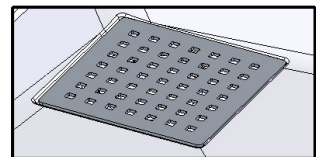
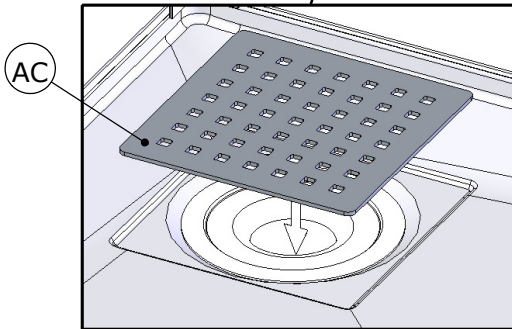
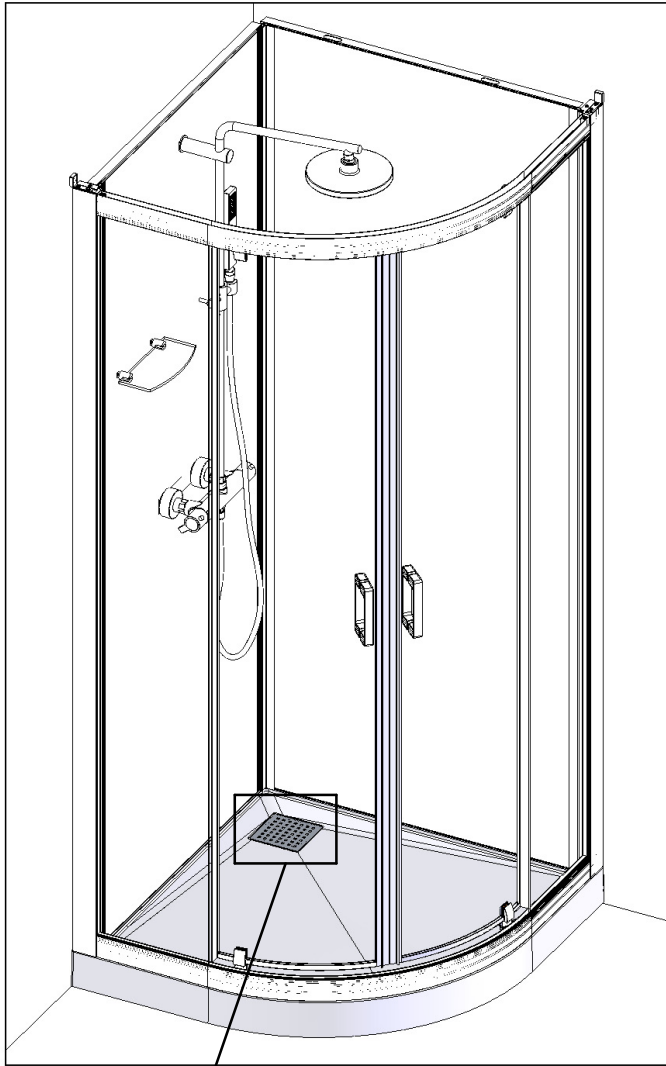

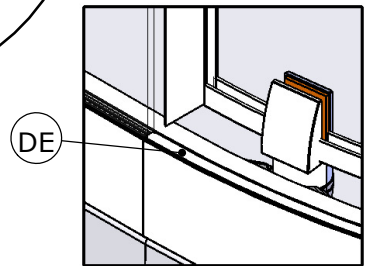
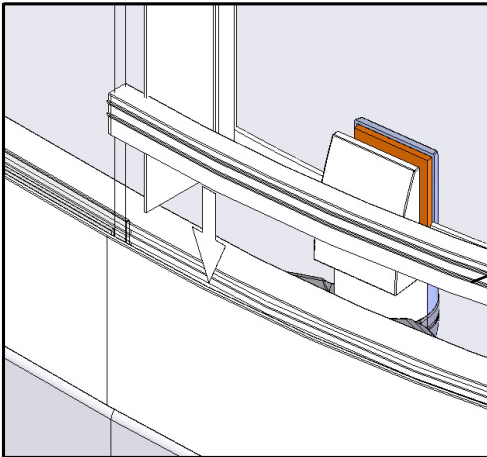
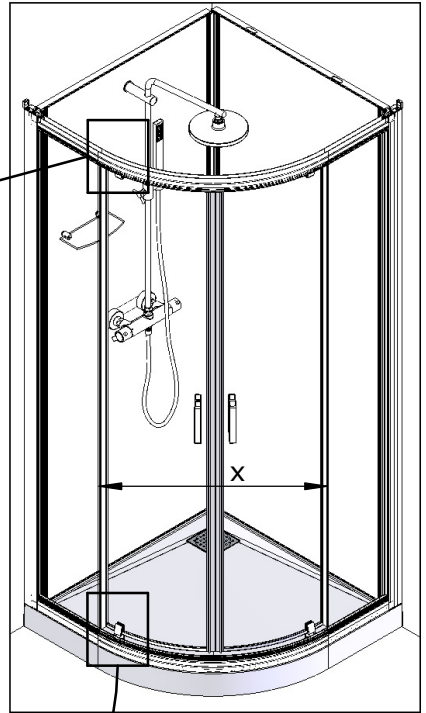
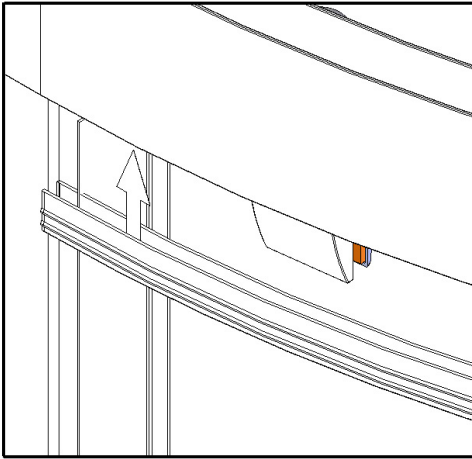
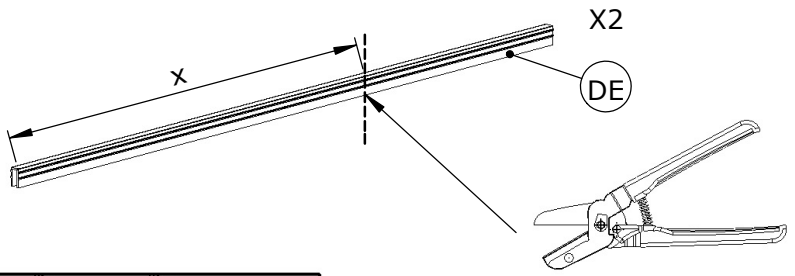



**1**

**F** Si nécessaire, desserrer, ajuster puis resserrer.

**GB** If necessary, untighten, adjust then tighten.

**E** Si es necesario, aflojen, ajuste y apriete.

**I** Se necessario, svitare, regolare quindi stringere.

**NL** Indien nodig, en los, passen draai.

**D** Bei Bedarf, lösen, anpassen dann anziehen.

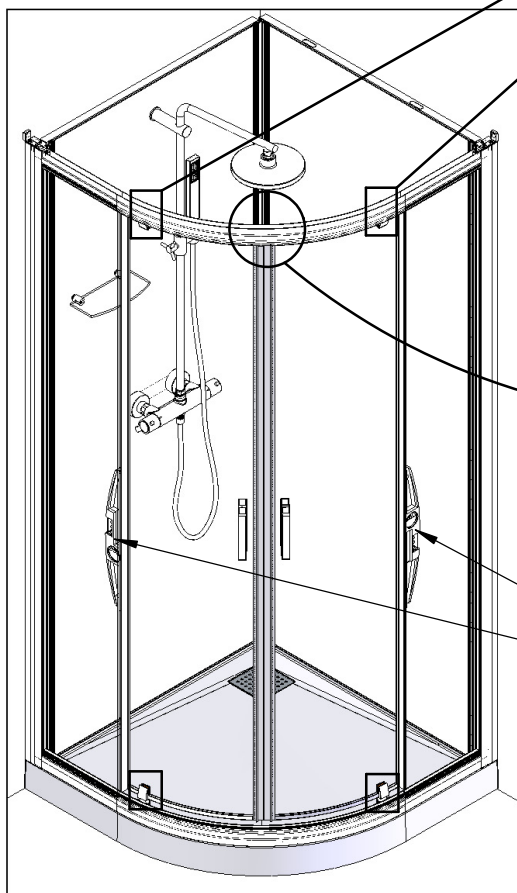
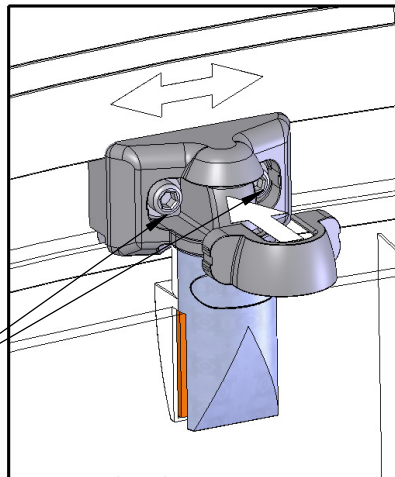
**2**

**F** Serrer.

**GB** Tighten.

**E** Apriete.

**I** Serrare.

**NL** Aandraaien.

**D** Festziehen.

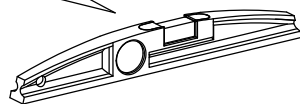
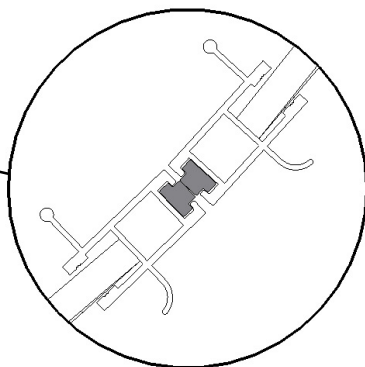



**NOTICE D'ENTRETIEN  
MAINTENANCE INSTRUCTIONS  
ISTRUZIONI DI MANUTENZIONE  
INSTRUCCIONES DE MANTENIMIENTO  
ONDERHOUDSINSTRUCTIE  
WARTUNGSANLEITUNG**



**SCAN ME**





## SERVICE APRÈS-VENTE AFTER-SALES SERVICE

### FRANCE

+33 (0)2 40 21 29 45

### UK

+44 (0)20 8842 0033

### IRELAND

+353 04697 33102

### DEUTSCHLAND

+49 (0) 6074 / 30928 0

### ITALIA

+39 (0382) 6181

### ÖSTEREICH

+43 1 710 60 70

### SUISSE/SCHWEIZ

+41 (0)32 631 04 74

### ESPAÑA

+34 93 544 60 76

### NEDERLAND

+31 475 487 100

### BELGIQUE/BELGIË

+31 475 487 100

### РОССИЯ

+7 495 258-29-51

### PORTUGAL

+351 219 112 785