

Kinedo

DES1459-F

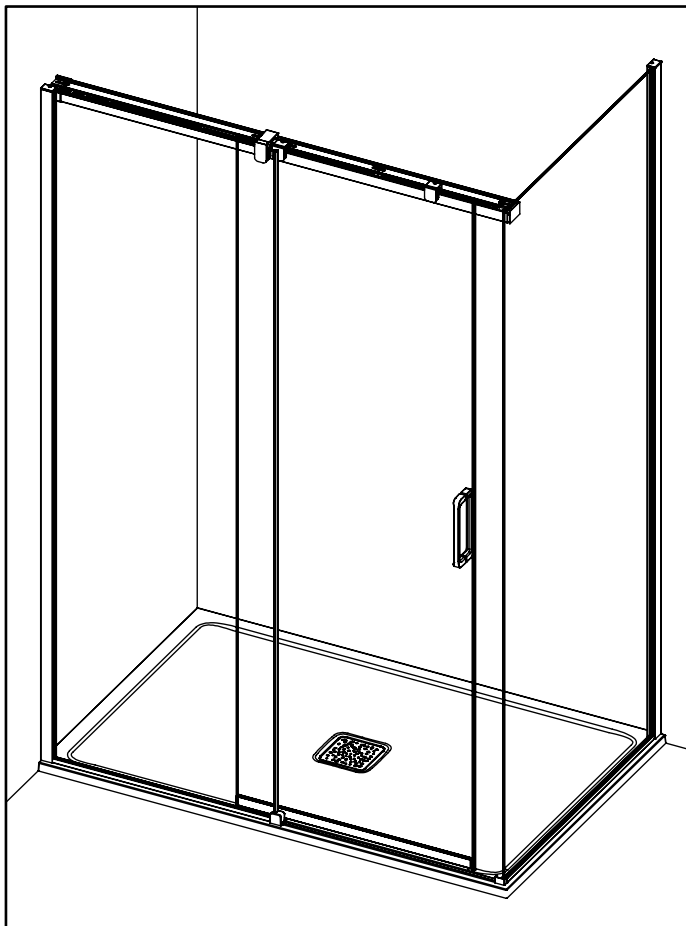



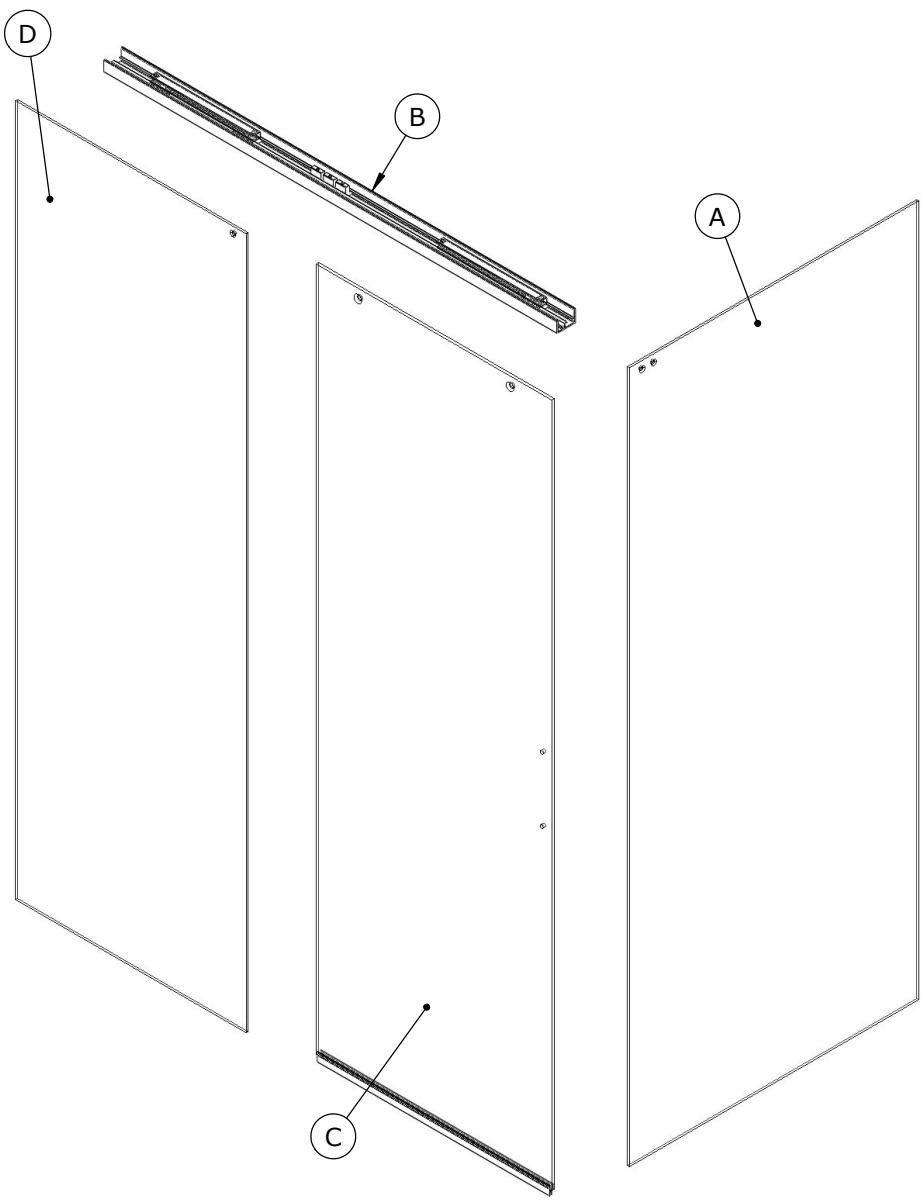

NOTICE DE MONTAGE / INSTALLATION INSTRUCTIONS / MANUAL DE INSTALACIÓN / MANUAL DE INSTALAÇÃO
ISTRUZIONI DI MONTAGGIO / INSTALLATIE VOORSCHRIFTEN / INSTALLATIONSANLEITUNG

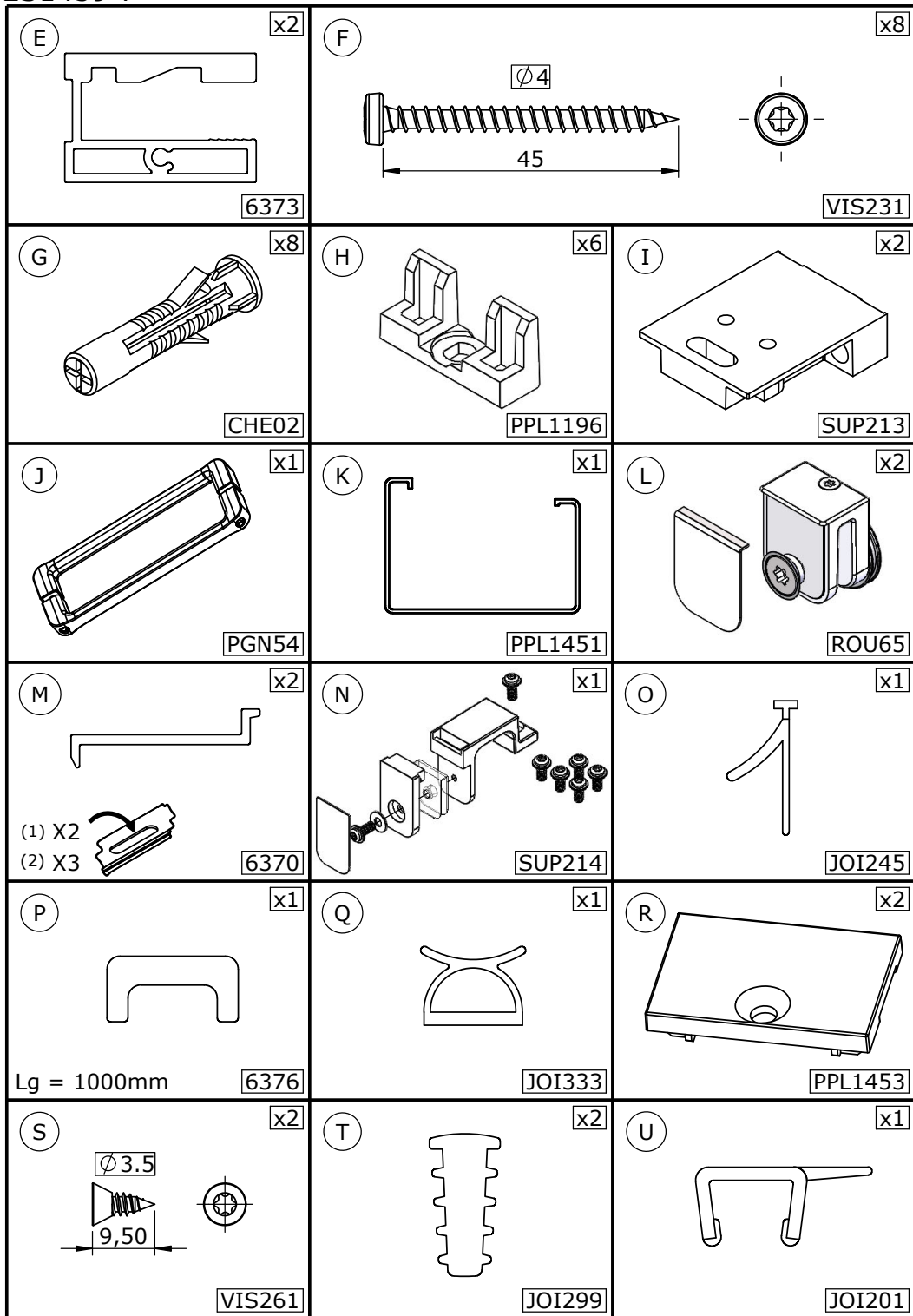

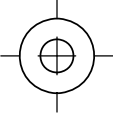
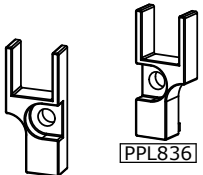
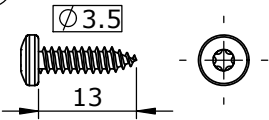
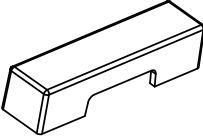
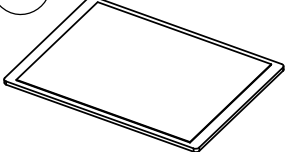
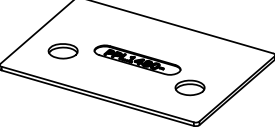

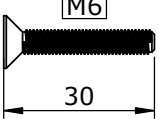

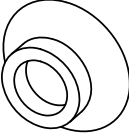
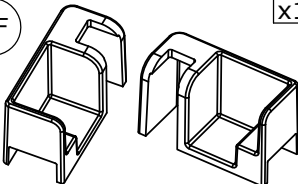
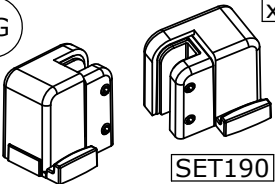
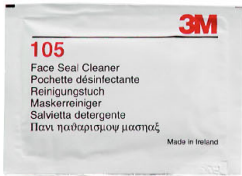
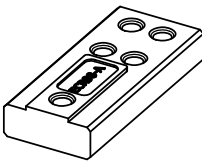
<p>V x2</p>  <p>Lg=1400mm 6382</p>	<p>W x4</p>  <p style="text-align: center;"> </p> <p style="text-align: center;">RON05</p>	<p>X x1</p>  <p>PPL835 PPL836</p>
<p>Y x2</p>  <p style="text-align: center;">VIS217</p>	<p>Z x2</p>  <p style="text-align: center;">PPL1226</p>	<p>AA x1</p>  <p style="text-align: center;">TOL147</p>
<p>AB x1</p>  <p style="text-align: center;">PPL1480</p>	<p>AC x2</p> <p>M6</p>  <p style="text-align: center;">ECR103</p>	<p>AD x2</p>   <p style="text-align: center;">VIS284</p>
<p>AE x2</p>  <p style="text-align: center;">PPL1450</p>	<p>AF x1</p>  <p>PPL1508 PPL1509</p>	<p>AG x1</p>  <p>SET189 SET190</p>
<p>AH x1</p>  <p style="text-align: center;">LING03</p>	<p>AI x2</p>  <p style="text-align: center;">ECR98</p>	

Les quantités données sont les quantités utiles au montage. les sachets fournis contiennent des pièces supplémentaires.
 The quantities given are what are required for the installation. There may be some surplus in the package provide.
 Las cantidades indicadas son las cantidades necesarias para el montaje. Las bolsitas incluidas contienen piezas suplementarias.
 As quantidades indicadas são as quantidades necessárias para a montagem. Os sacos fechados contém peças adicionais.
 Le quantità fornite sono le quantità necessarie al montaggio. I sacchetti forniti contengono pezzi supplementari.
 De aangegeven aantallen zijn vereist voor de montage. De verpakking bevat extra onderdelen.
 Die Mengenangaben beziehen sich auf die für die Montage nötigen Teile. Eventuell weitere beige-packte Teile ignorieren.

Matériel nécessaire - Tools required
 Equipamento necesario - Equipamento necessário
 Materiale necessario - Benodigd gereedschap - Benötigte Werkzeuge

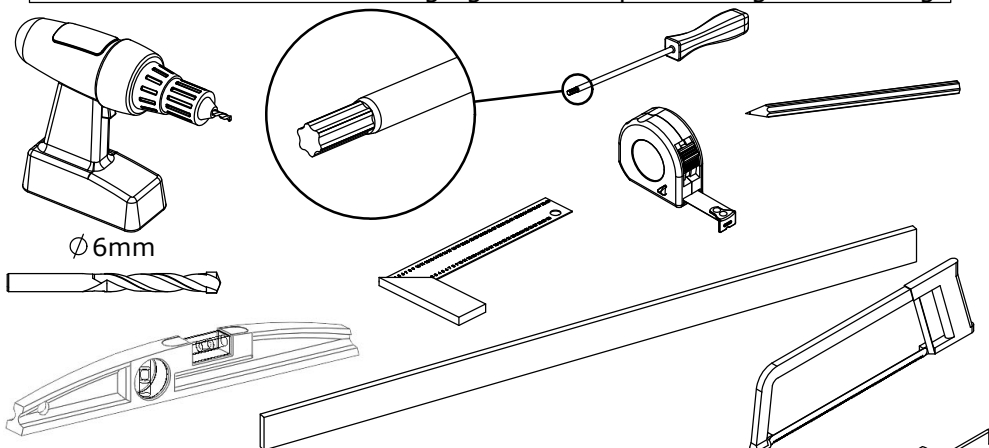

Utiliser un silicone adapté au matériau de chaque support (faïence, acrylique, etc.)

Use a silicone sealant that is intended for the surrounding materials (ceramic, acrylic, etc.)

Usar una silicona adecuada para cada tipo de material (loza, acrílico, etc.)

Utilizar um silicone adequado a cada tipo de material (louça, acrílico, etc.)

Utilizzare un silicone adatto a qualsiasi materiale (ceramica, acrilico, ecc.)

Gebruik siliconenkit die geschikt is voor iedere ondergrond (tegelwerk, acryl, etc.)

Für das jeweilige Trägermaterial (Stein, Acryl usw.) geeignetes Silikon verwenden.

Fournit dans la boîte d'accessoires - Supplied in the accessory box -
 Se suministra en la caja de accesorios - fornecido na embalagem -
 Fornito nella scatola degli accesri -
 Meegeleverd in de verpakking - Im Zubehörset enthalten

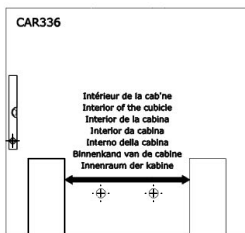

CAR336

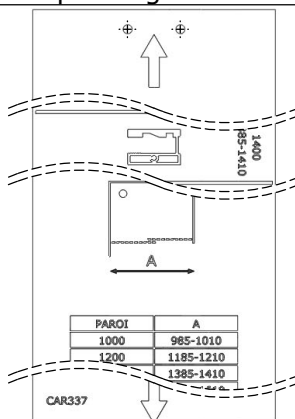

CAR337

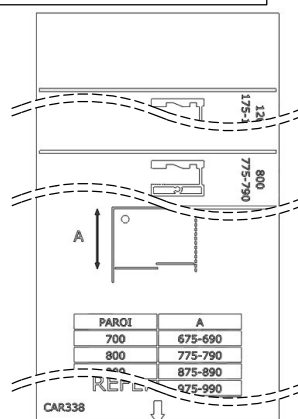

CAR338



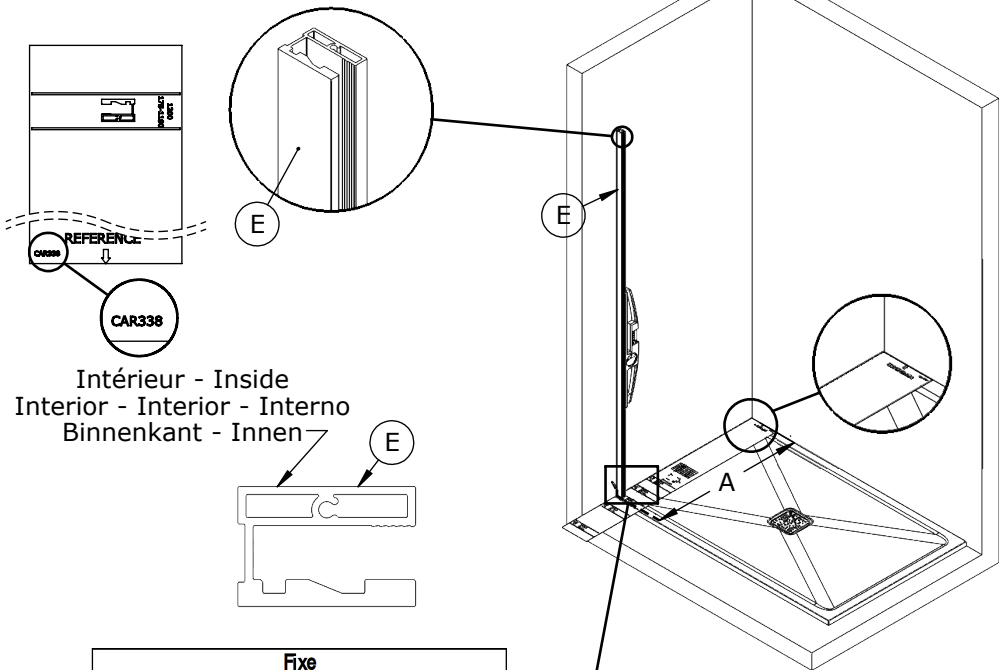

Intérieur - Inside
 Interior - Interior - Interno
 Binnenkant - Innen

Fixe				
Cm				
	Taille 70	Taille 80	Taille 90	Taille 100
A	65,5/70	77,5/80	87,5/90	97,5/100

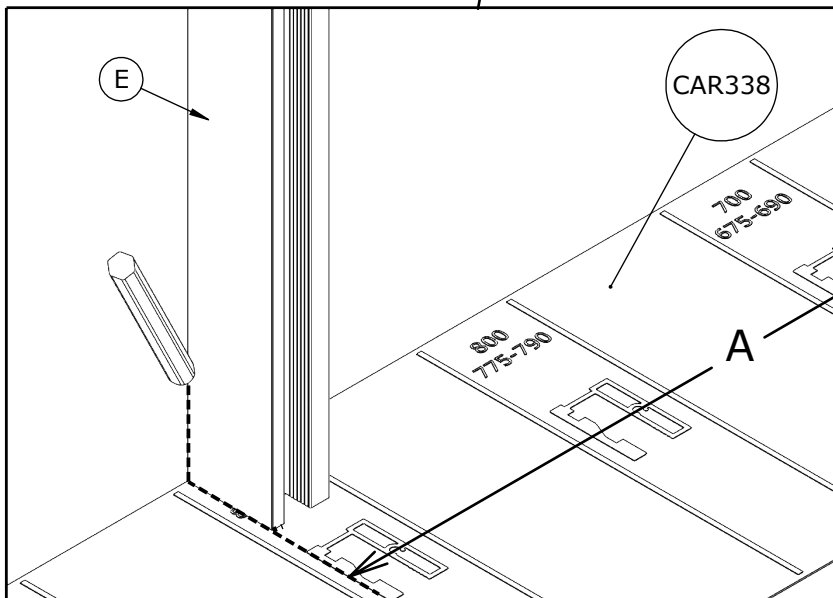

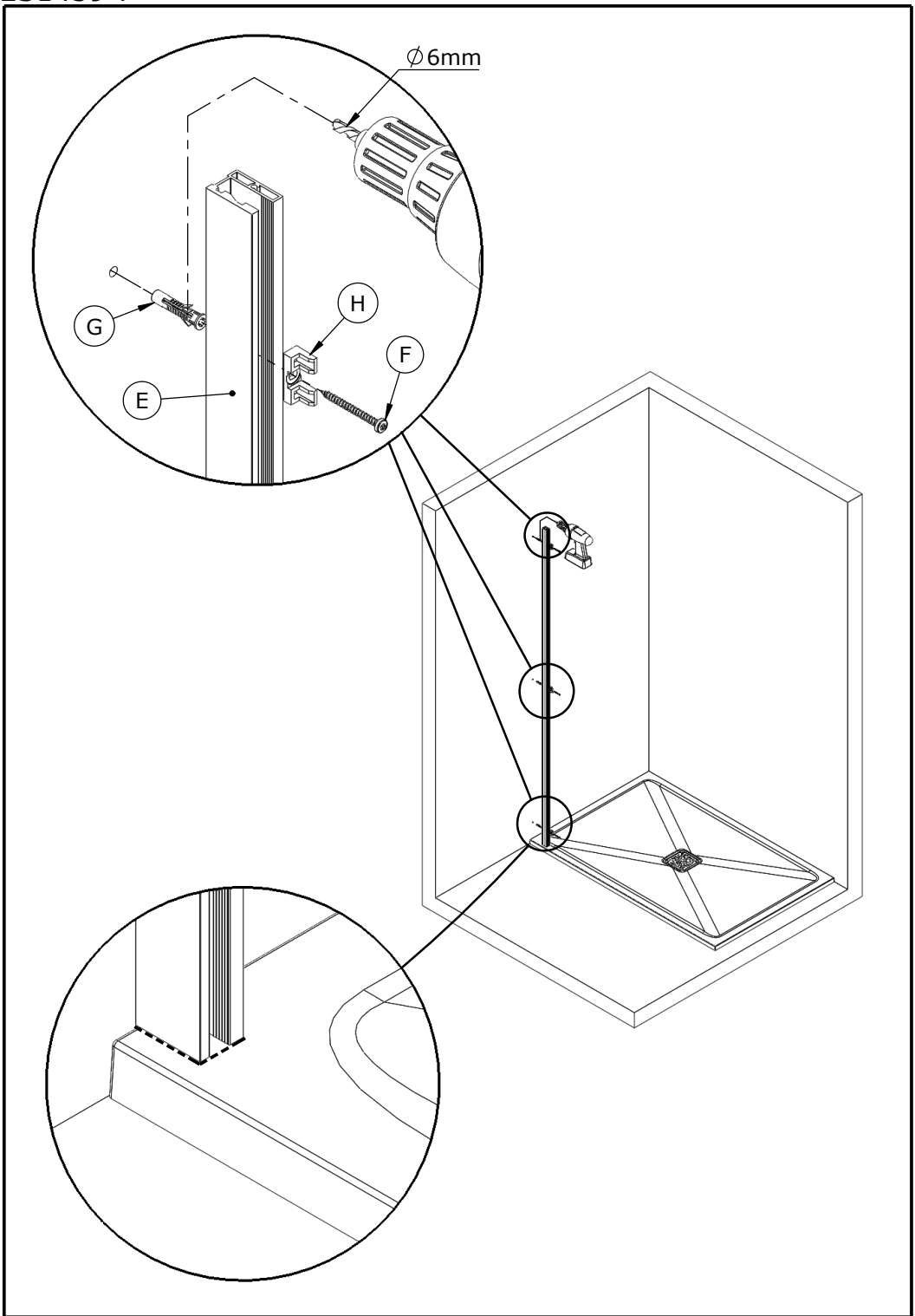

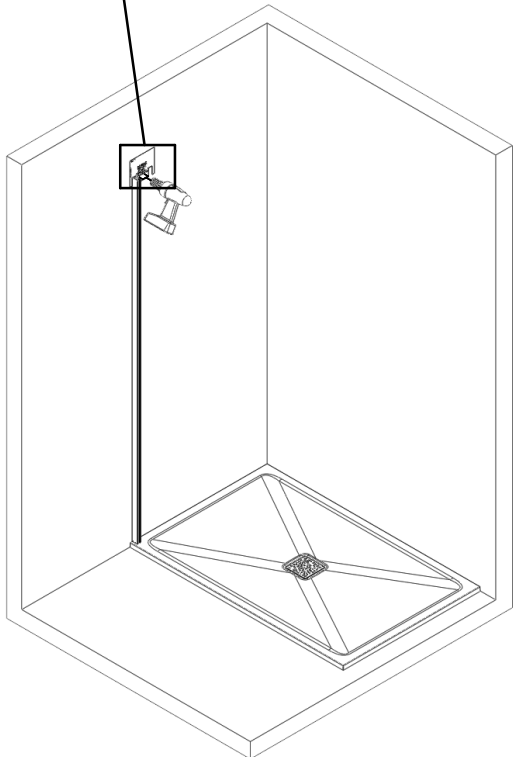
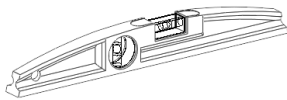
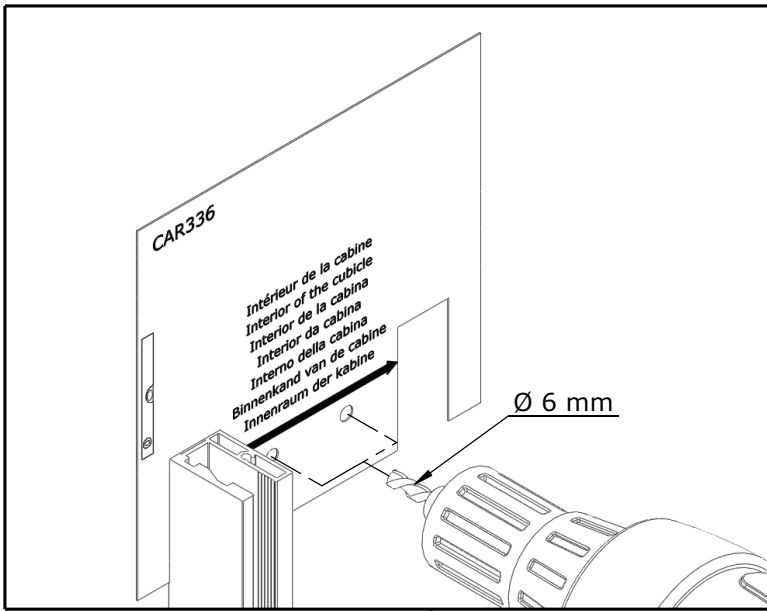

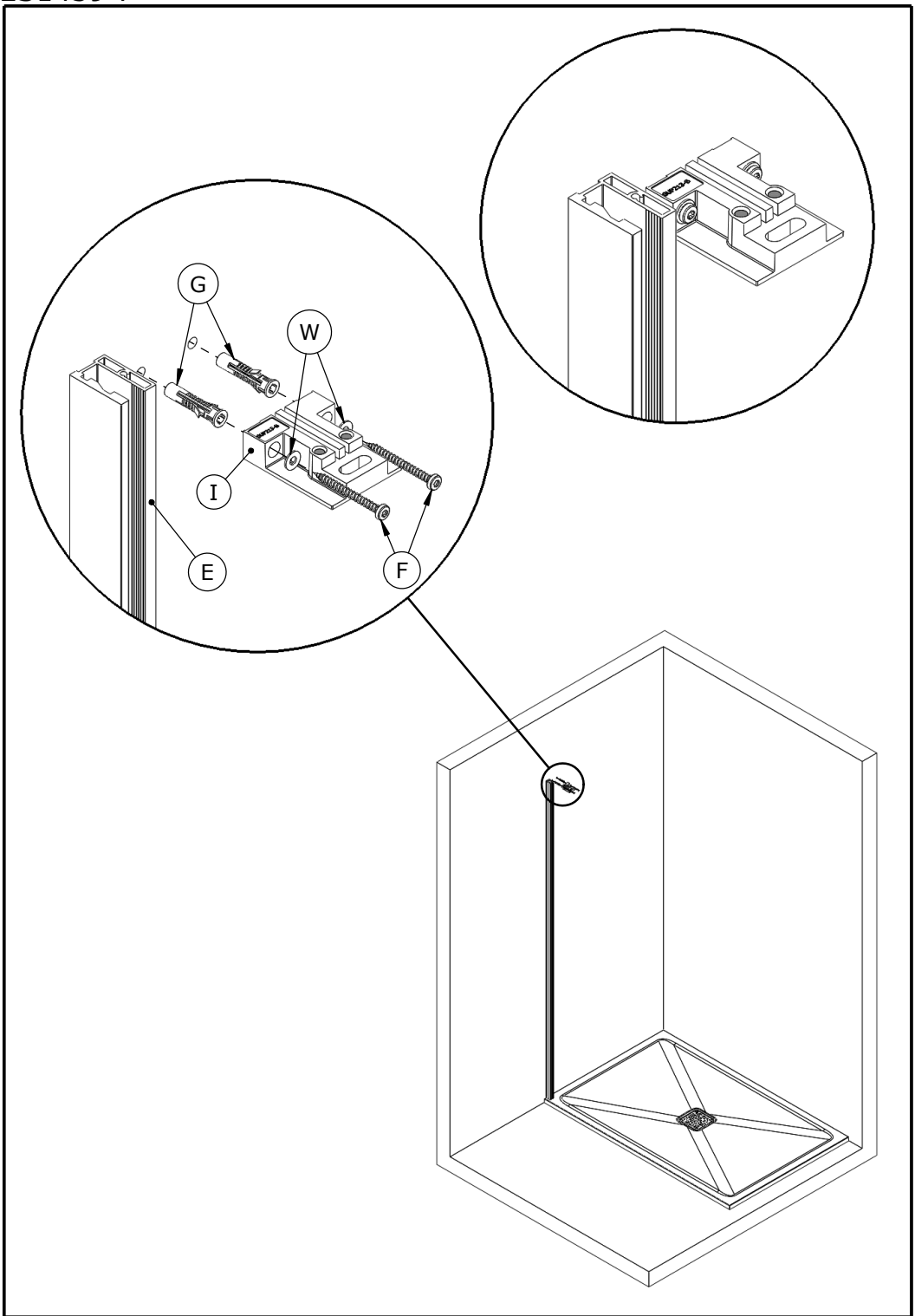

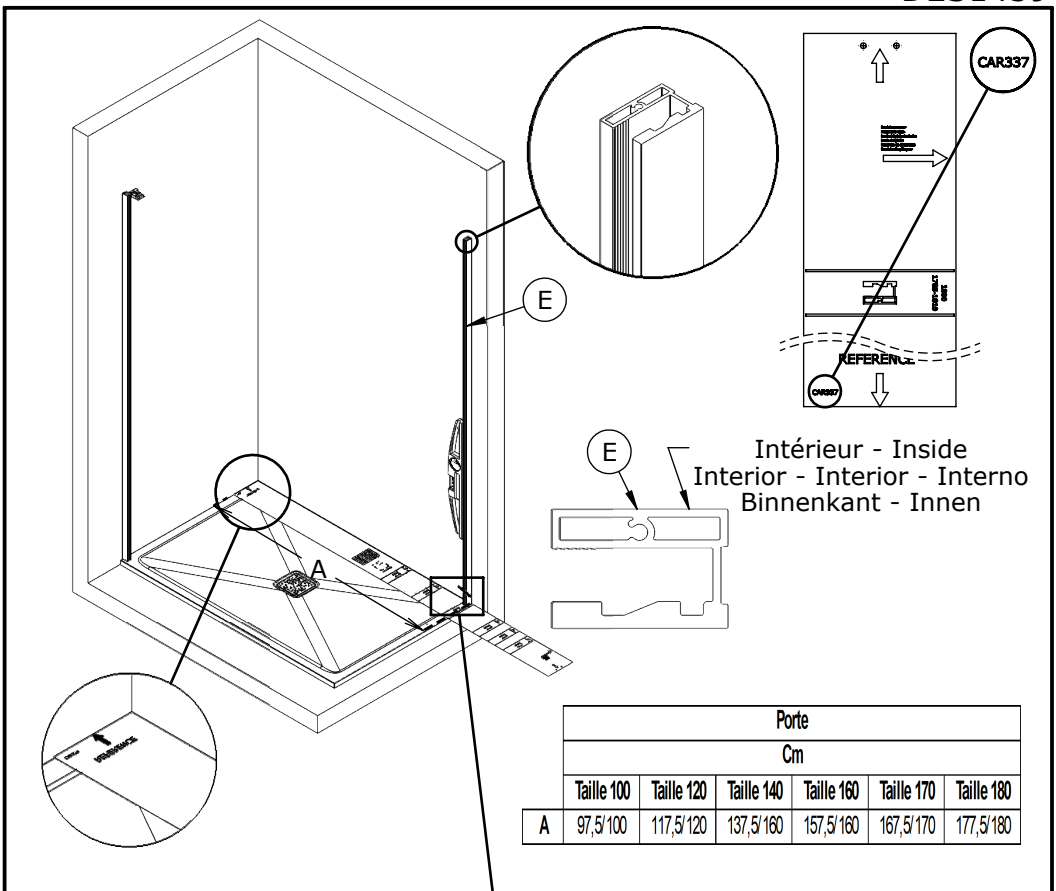

Intérieur - Inside
 Interior - Interior - Interno
 Binnenkant - Innen

Porte						
Cm						
Taille 100	Taille 120	Taille 140	Taille 160	Taille 170	Taille 180	
A	97,5/100	117,5/120	137,5/160	157,5/160	167,5/170	177,5/180

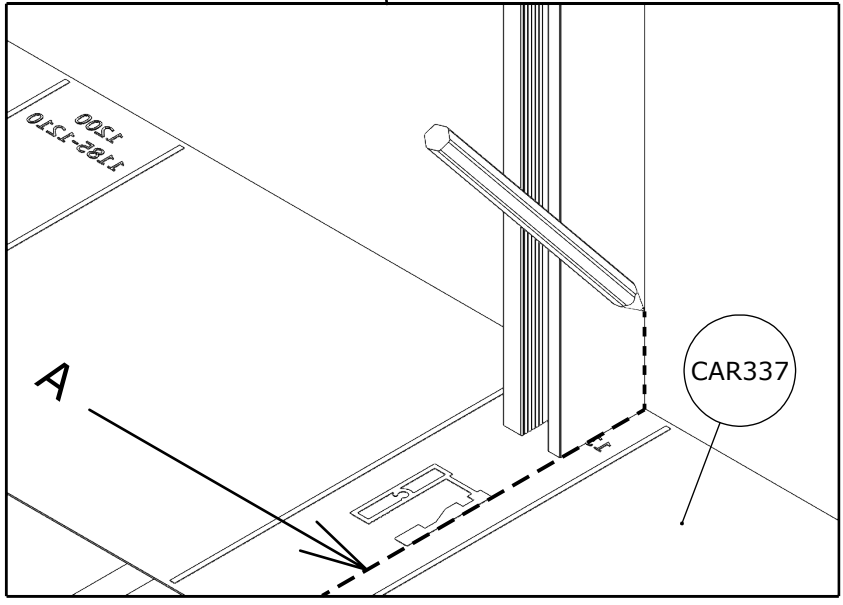

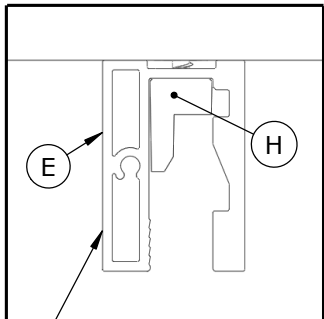
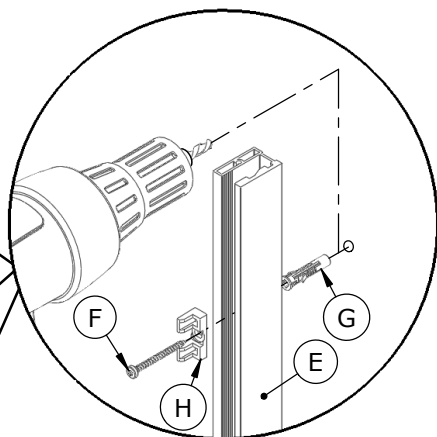
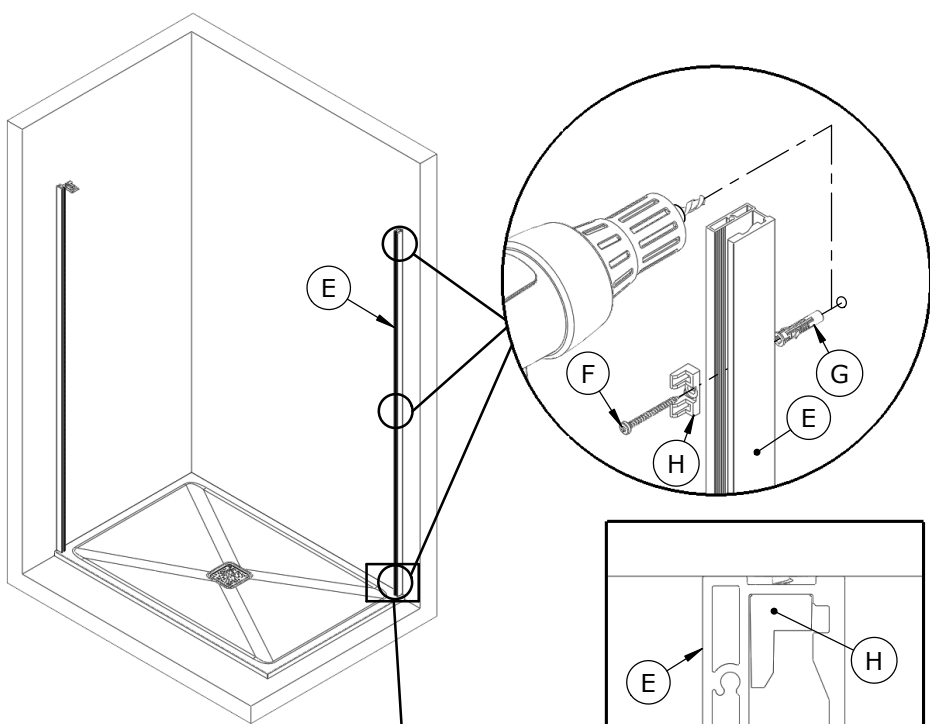

Intérieur - Inside
Interior - Interior - Interno
Binnenkant - Innen

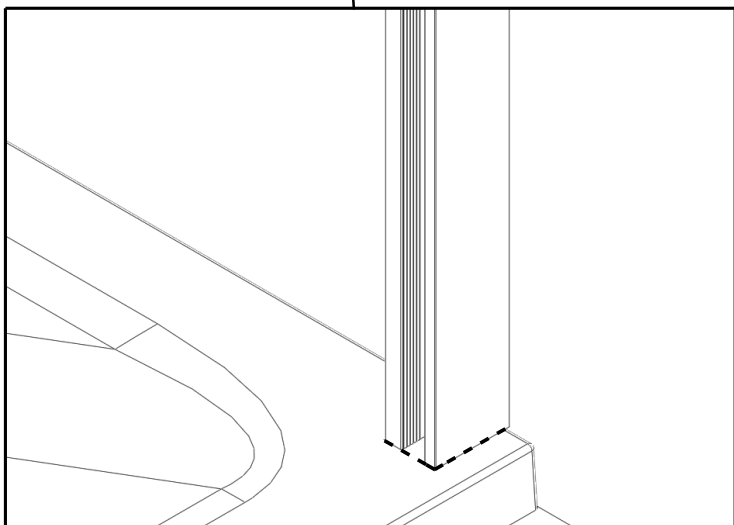

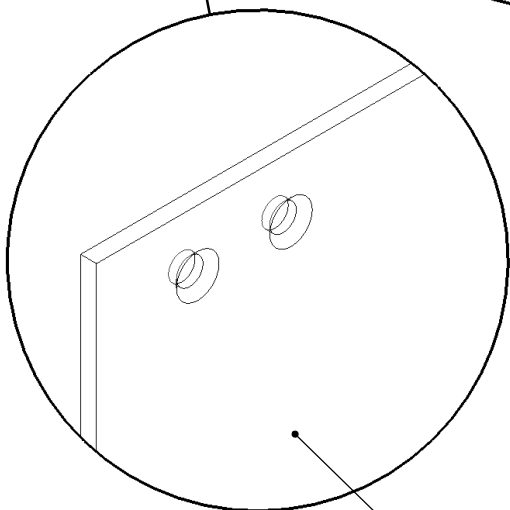
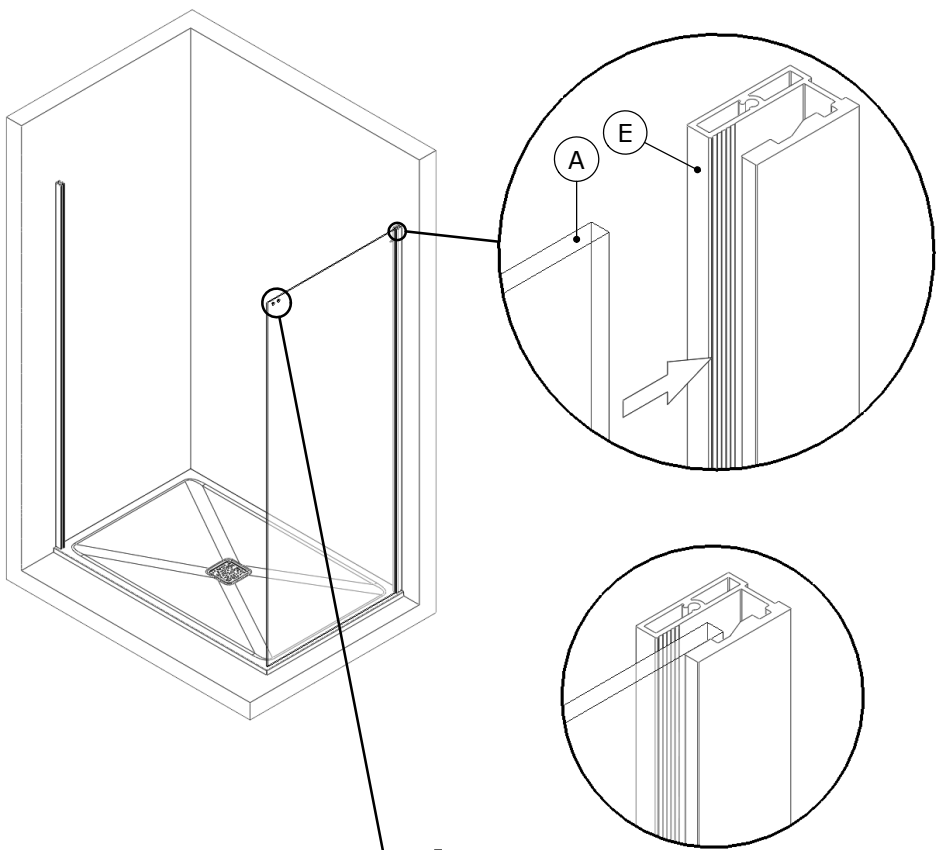

Extérieur - Outside
Externo - Exterior - Esterno
Buitenkant - Außen

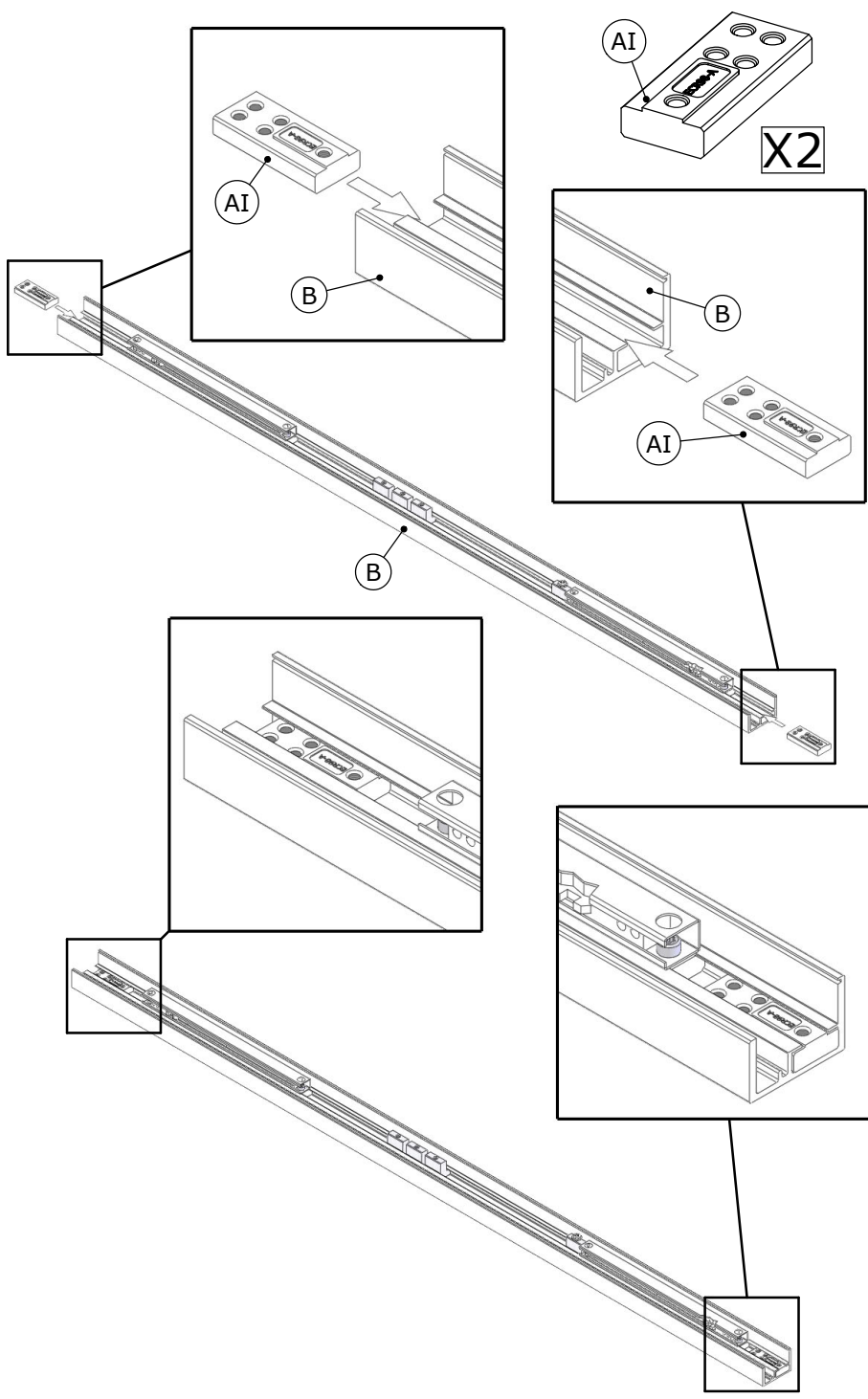

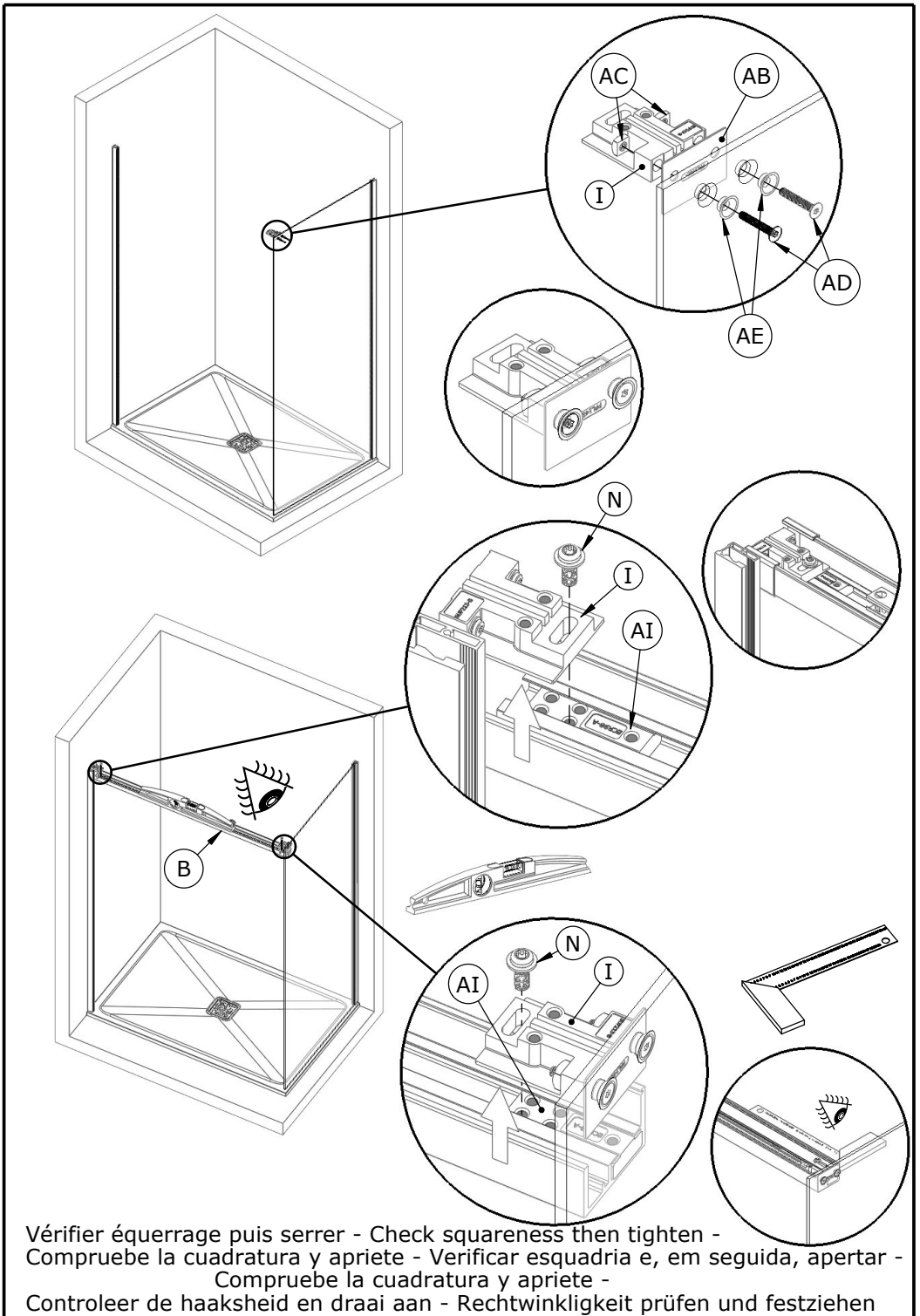

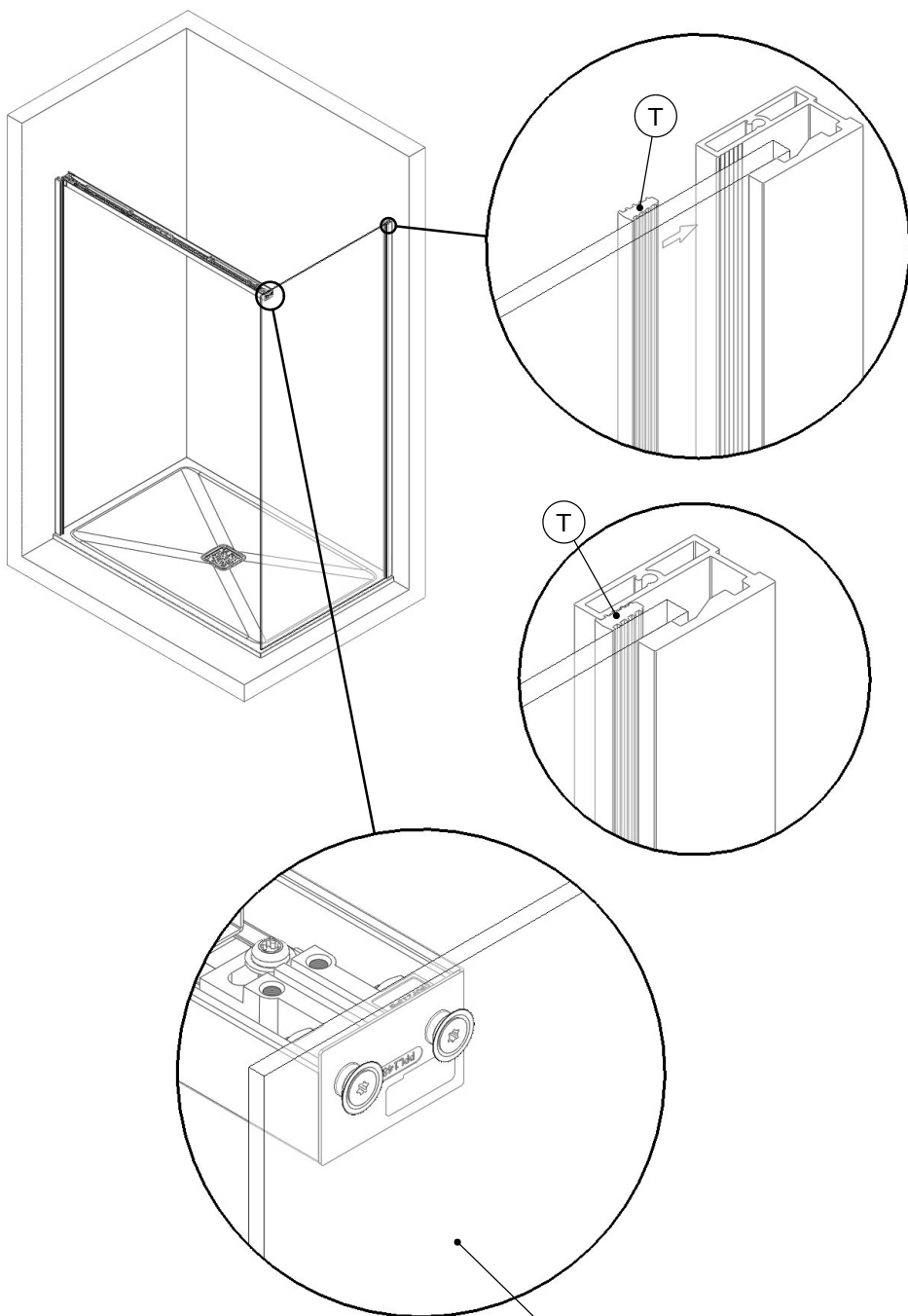

Extérieur - Outside
Externo - Exterior - Esterno
Buitenkant - Außen

Intérieur douche
 Inside shower
 Interior ducha
 Interior duche
 Doccia interni
 Binnenkant van de douche
 Innenraum der Kabine

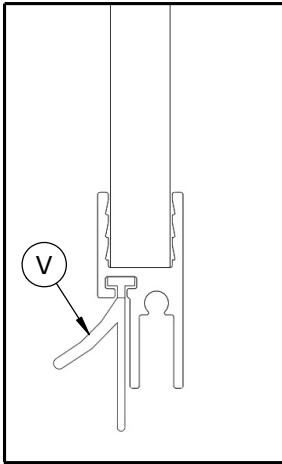

Intérieur - Inside
 Interior - Interior - Interno -
 Binnenkant - Innen

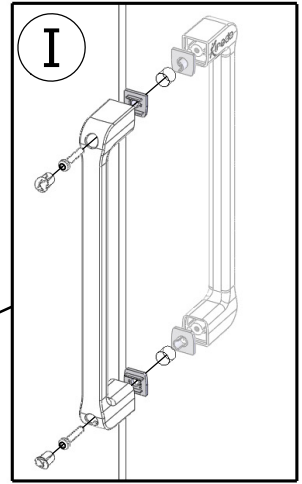
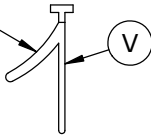

Intérieur - Inside
 Interior - Interior - Interno -
 Binnenkant - Innen

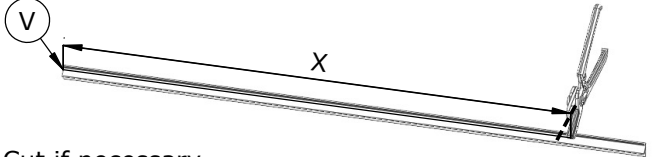
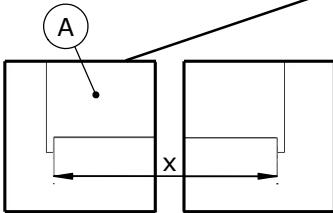
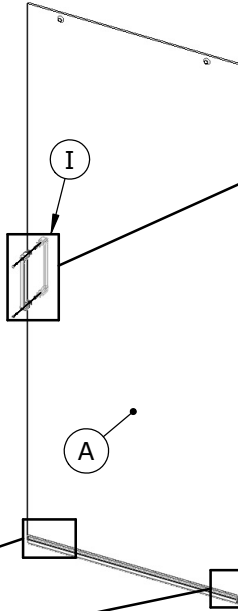

Couper si nécessaire - Cut if necessary
 Recortar si necesario - Cortar, se necessário -
 Tagliare si necessario -
 Snijd de strips, indien nodig - Bei Bedarf zuschneiden.

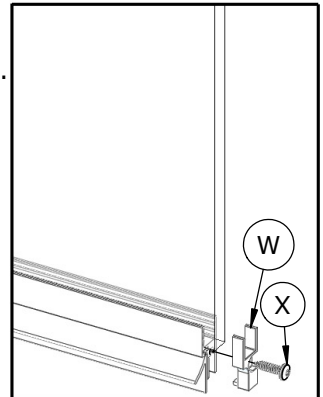
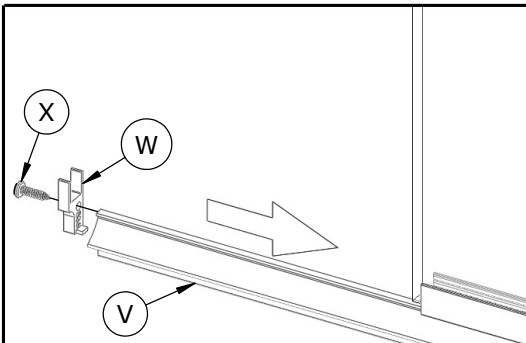

Intérieur - Inside
 Interior - Interior - Interno -
 Binnenkant - Innen

Extérieur - Outside
 Externo - Exterior - Esterno
 Buitnenkant - Außen

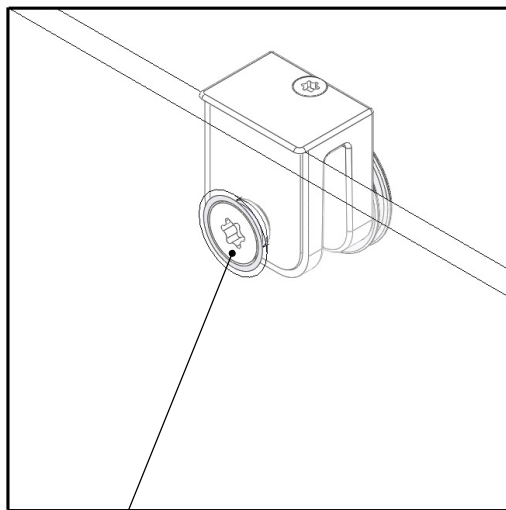
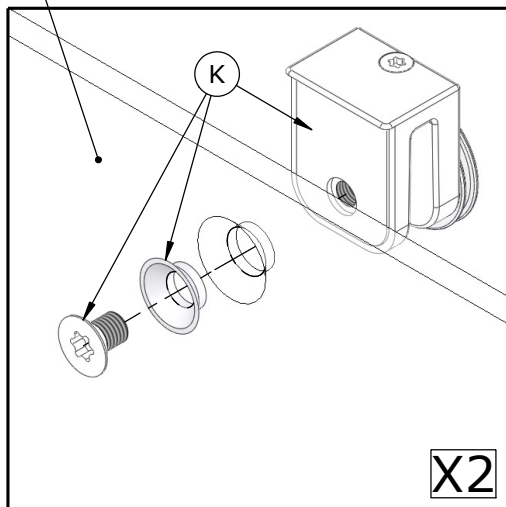

Serrer - Tighten
 Apriete - Apertar - Serrare
 Vastdraaien - Festziehen

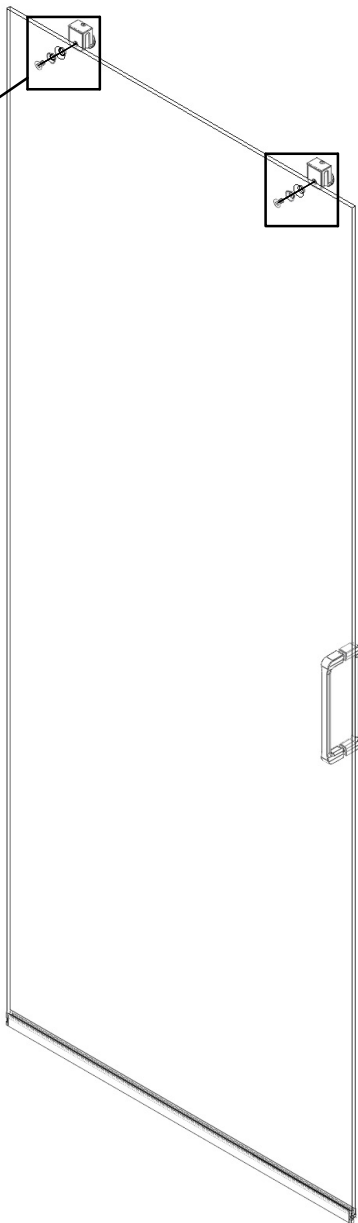

Couple de serrage - Tightening torque -
 Par de apriete - torque de aperto - Coppia di serraggio -
 Klembeugel - Anzugsdrehmoment



6N.m

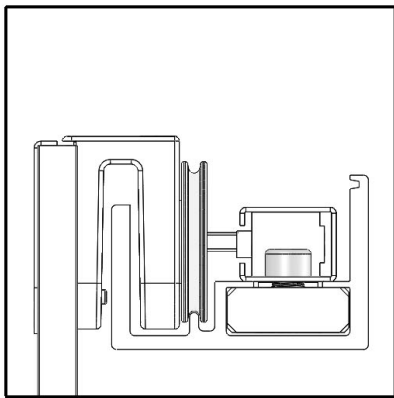
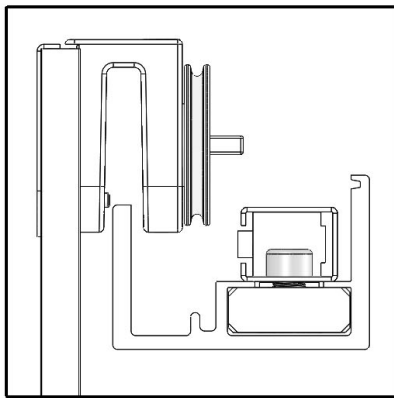
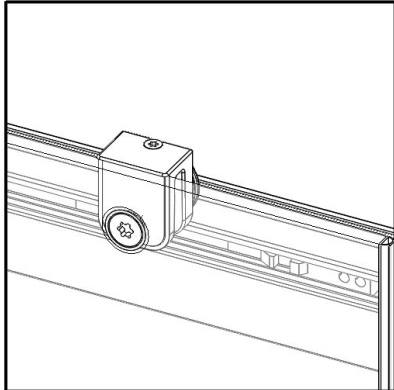
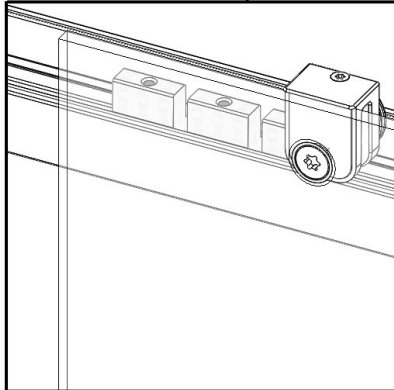
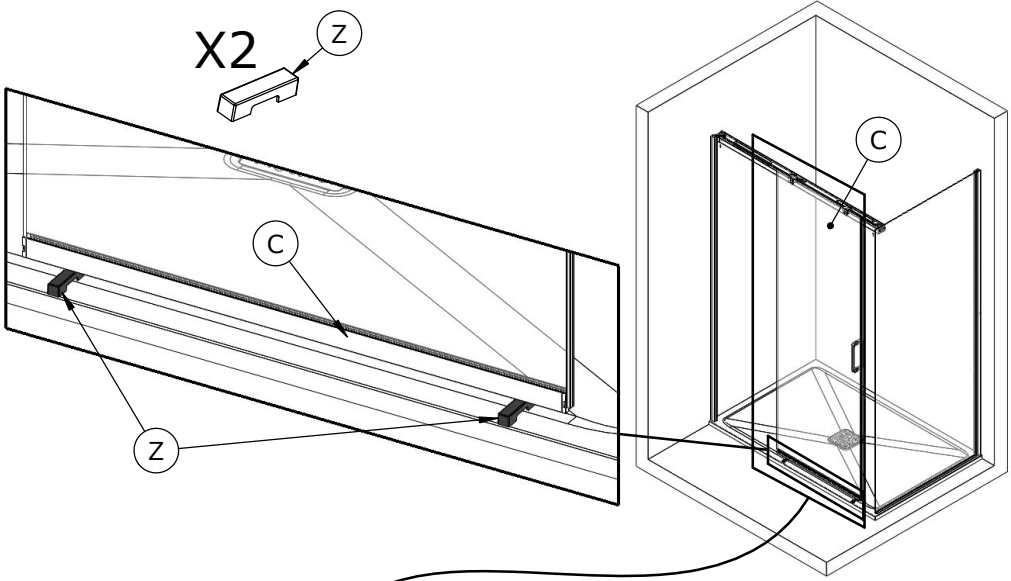

X2

Retirer (Z) - Remove (Z)
 Quitar (Z) - Retirar (Z) - Togliere (Z)
 Verwijderen (Z) - Entfernen (Z)

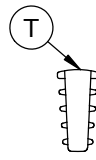
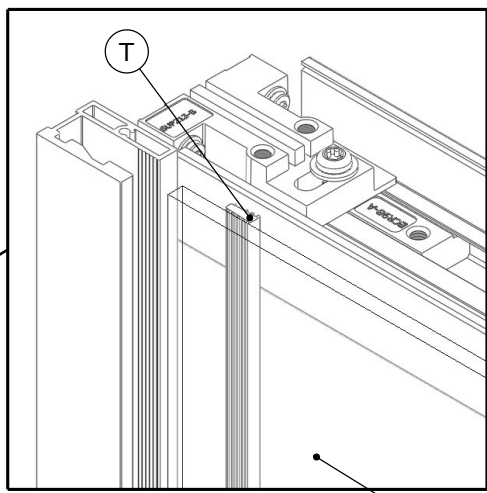
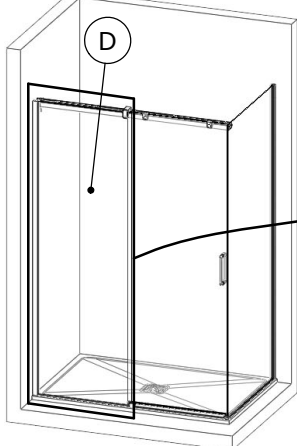

Intérieur - Inside
 Interior - Interior - Interno
 Binnenkant - Innen

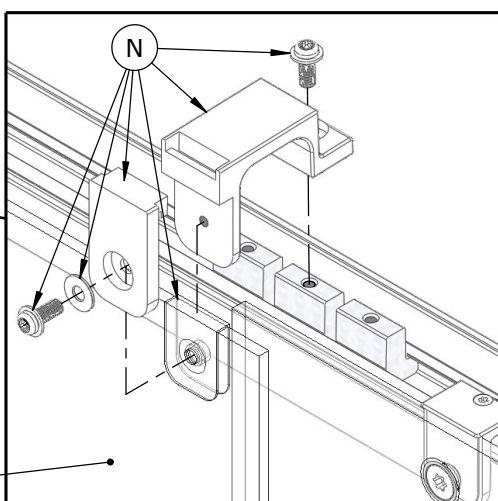
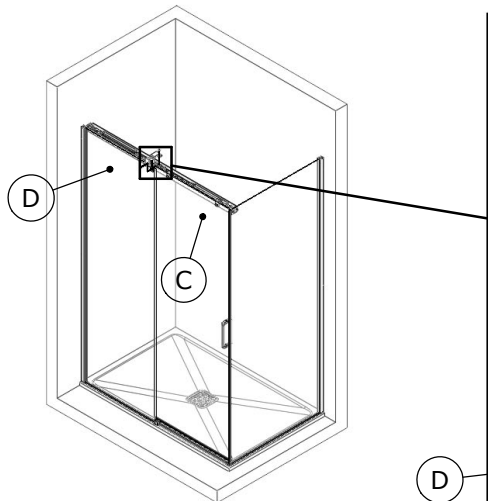
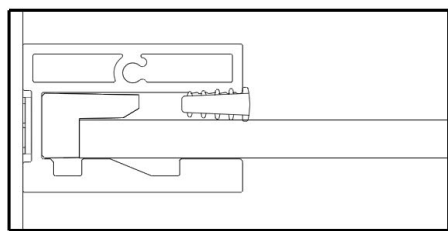
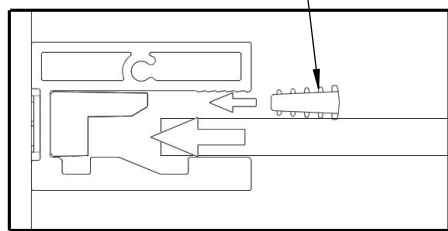

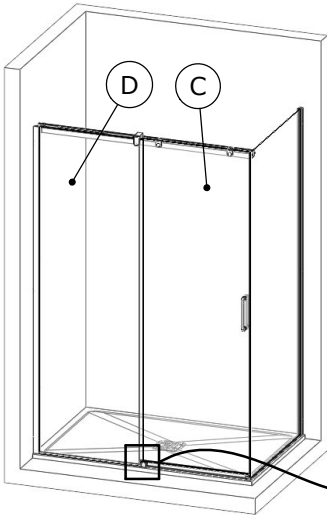

Silicone - Silicone
 Silicona - Silicone
 Silicone
 Silicone - Silikon

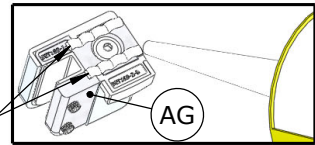

Serrer pour bloquer le verre
 Tighten on the glass

Apretar para inmovilizar el crista

Apertar para bloquear o vidro

Serrare per bloccare il vetro

Draai aan om het glas te vergrendelen

Anziehen, um das Glas zu arretieren

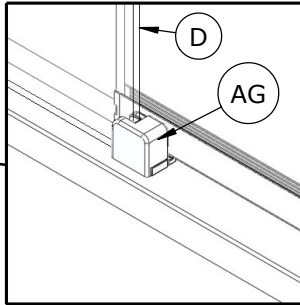

Extérieur - Outside
 Externo - Exterior -
 Esterno -
 Buitenkant - Außen

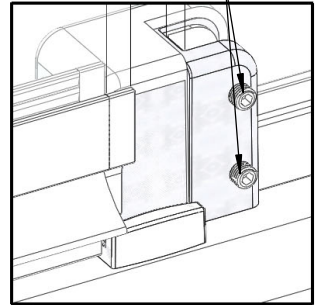

Intérieur - Inside
 Interior - Interior -
 Interno -
 Binnenkant - Innen

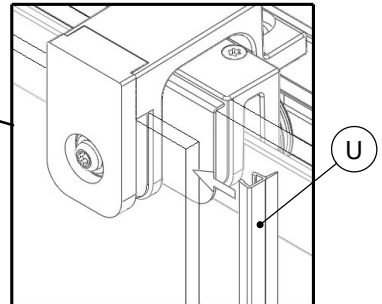
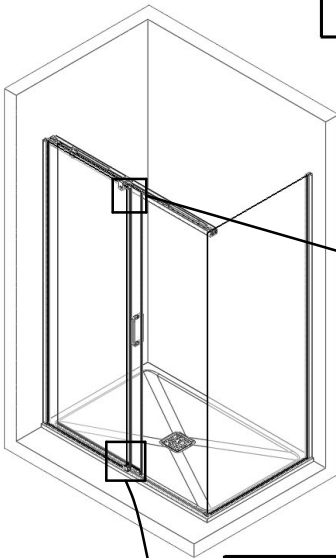

Affleurant
 Flush
 Affleurant
 Alinhado com
 Lavare
 Uitstekend
 Bündig

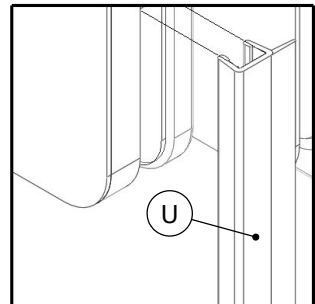
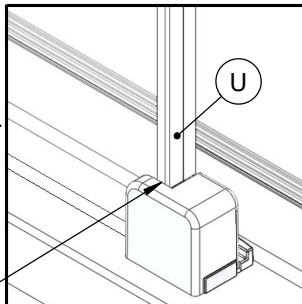

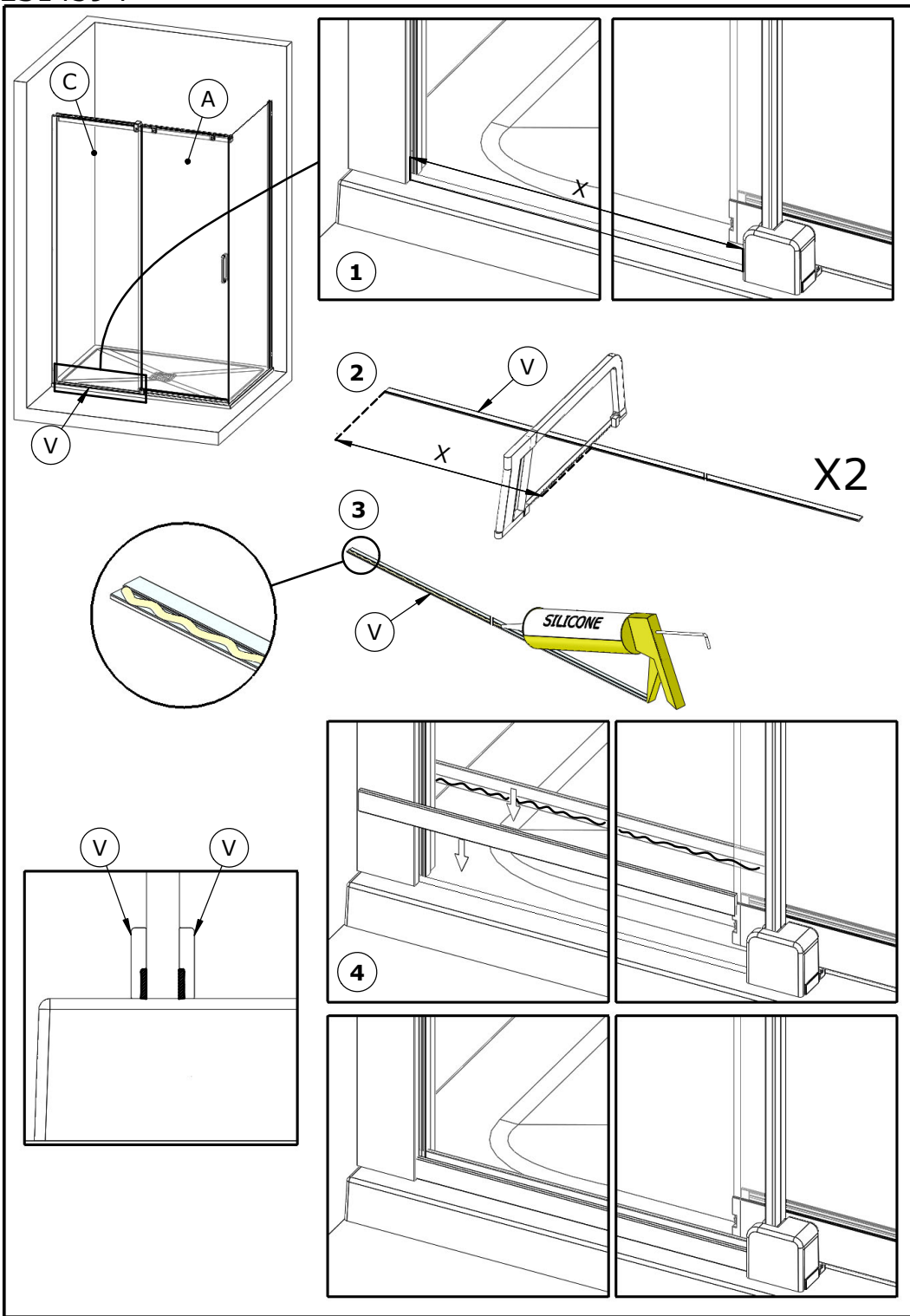

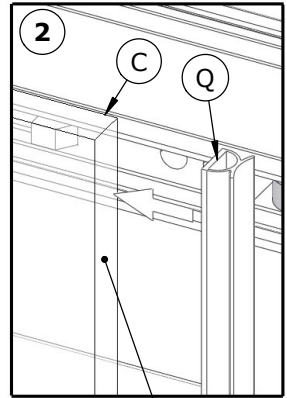
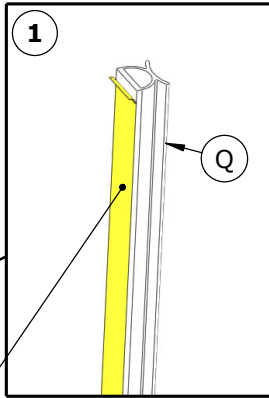
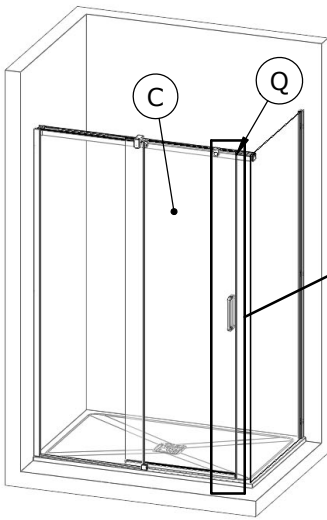

Retirer l'adhésif
Remove adhesive
Quitar el adhesivo
Rimuovere il adesivo
Verwijder de lijm
Klebstoff entfernen

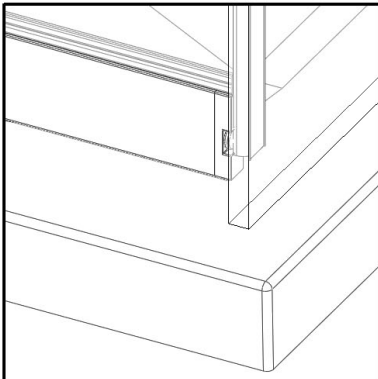
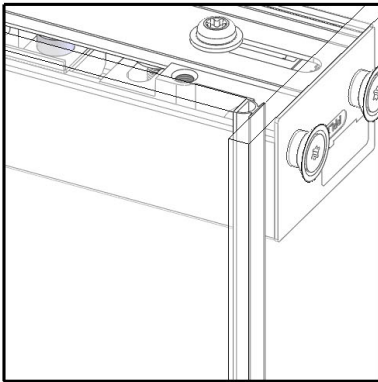

-Avant de coller (Q), la surface (C) doit être nettoyé, dégraissé et sans poussière, avec un nettoyant à base d'alcool

-Before gluing (Q), the surface (C) must be cleaned, degreased and dust-free, with an alcohol-based cleaner.

-Antes de pegar (Q), la superficie (C) debe ser limpiada, desengrasada y libre de polvo, con un limpiador a base de alcohol.

- Antes de colar (Q), a superfície (C) deve ser limpa, desengordurada e isenta de poeiras, com, um produto de limpeza à base de álcool.

-Prima di incollare (Q), la superficie (C) deve essere pulita, sgrassata e priva di polvere, con un detergente a base di alcool.

-Voor het verlijmen van (Q) moet het oppervlak (C) worden gereinigd, ontvet en stofvrij worden gemaakt met een reinigingsmiddel op alcoholbasis.

-Vor dem Verkleben von (Q) muss die Oberfläche (C) mit einem alkoholhaltigen Reiniger gereinigt, entfettet und staubfrei gemacht werden.

Réglage de la porte - Door adjustment - Adjust de la puerta - Ajustação da porta
 Regolazione porta - Afstellen van de deur - Einstellen der Tür

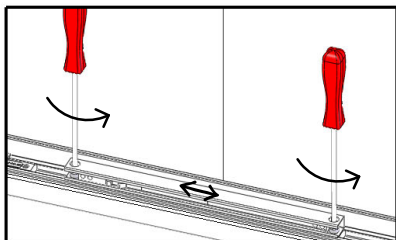
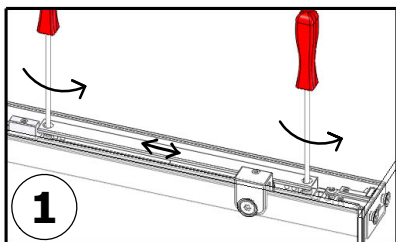

Desserer - Loosen - Aflojar - Desaperta
 Allentare - Losdraaien - Abschrauben

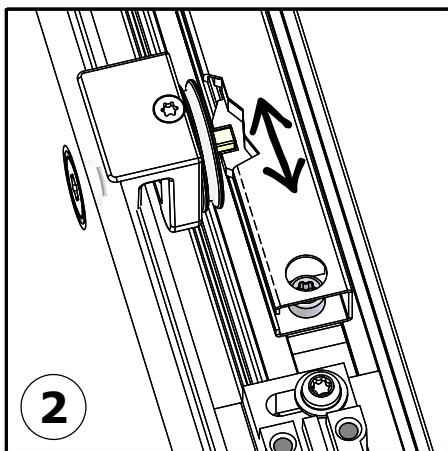

Régler - Adjust - Ajustar - Ajustar
 Regolare - Afstellen - Einstellen

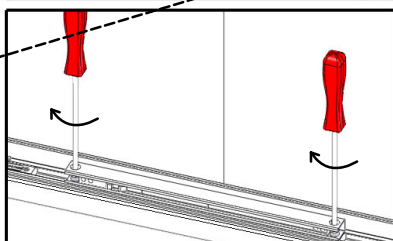
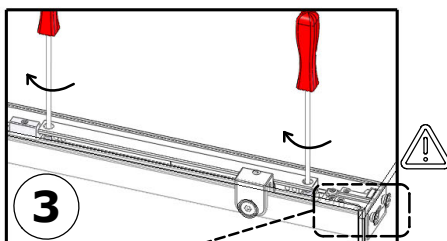
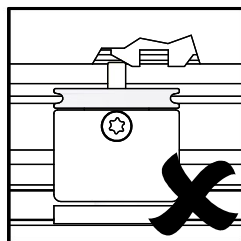
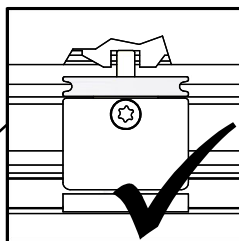
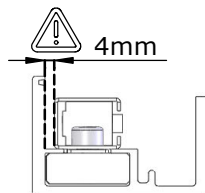

Serrer - Tighten - Apriete - Apertar
 Serrare - Vasdraaien - Festziehen

Réglage de la porte - Door adjustment - Adjust de la puerta - Afiinação da porta
 Regolazione porta - Afstellen van de deur - Einstellen der Tür

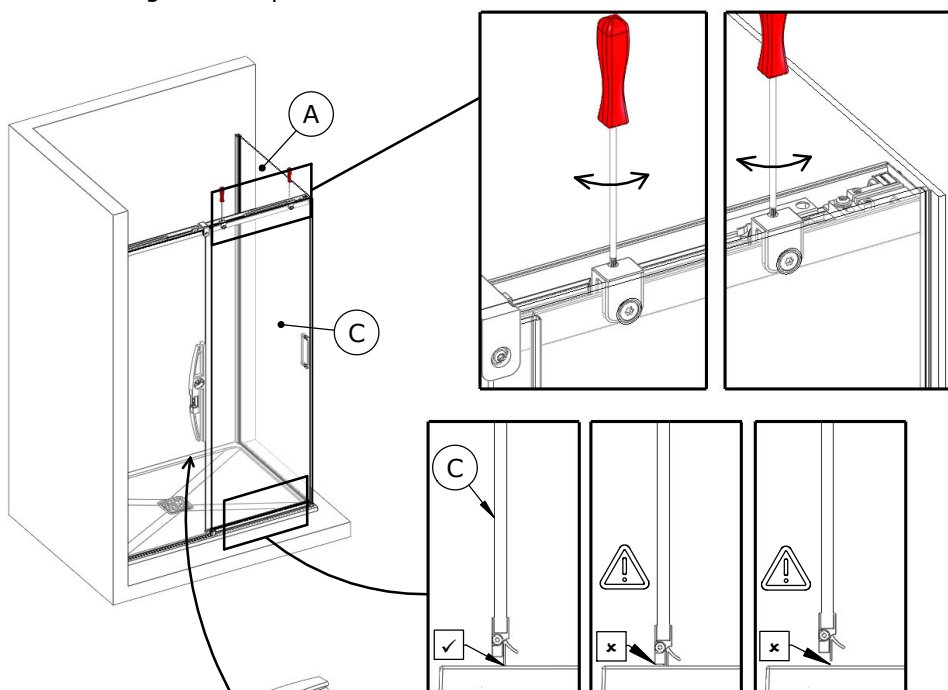

Ne dois pas frotter - Do not rub
 No debe rozar - Não roçar - Non deve toccare
 Niet wrijven - Nicht schrubben

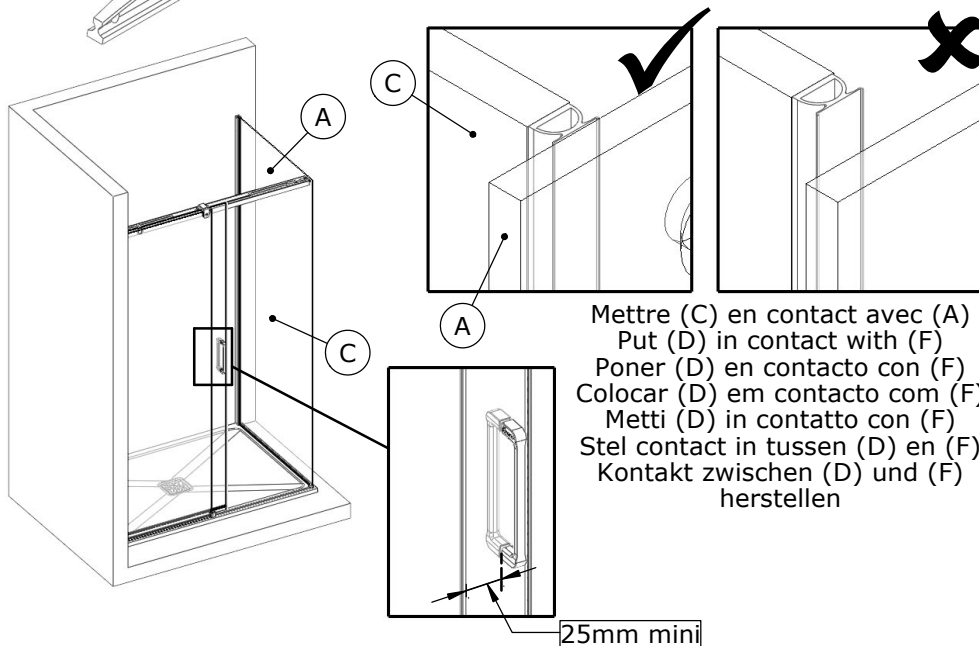

Mettre (C) en contact avec (A)
 Put (D) in contact with (F)
 Poner (D) en contacto con (F)
 Colocar (D) em contacto com (F)
 Metti (D) in contatto con (F)
 Stel contact in tussen (D) en (F)
 Kontakt zwischen (D) und (F)
 herstellen

25mm mini

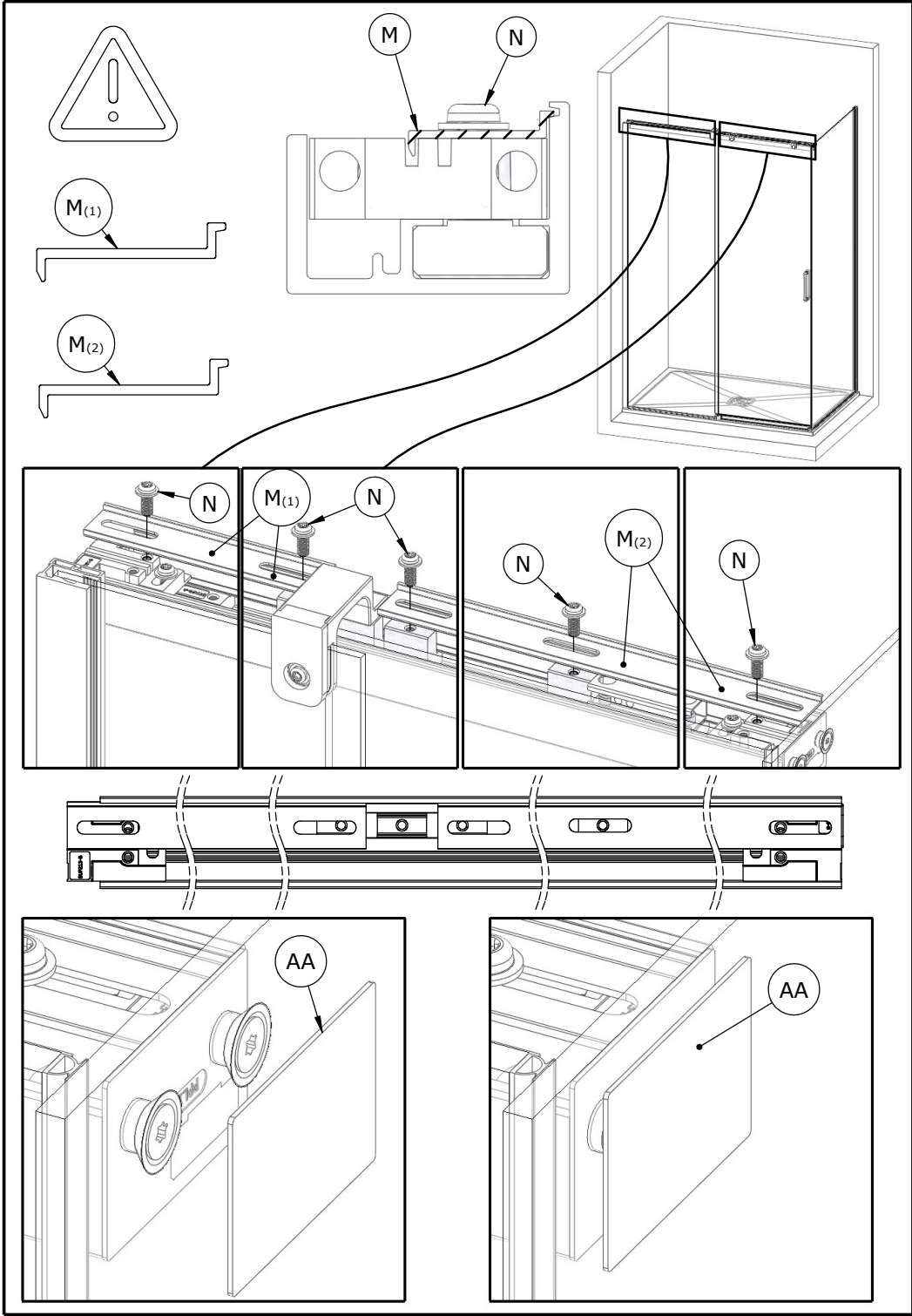

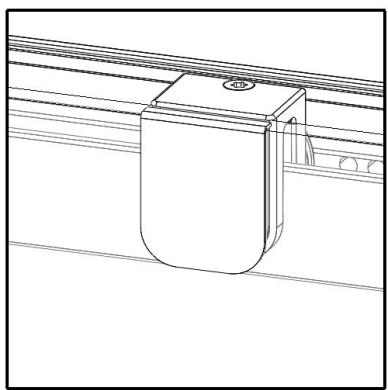
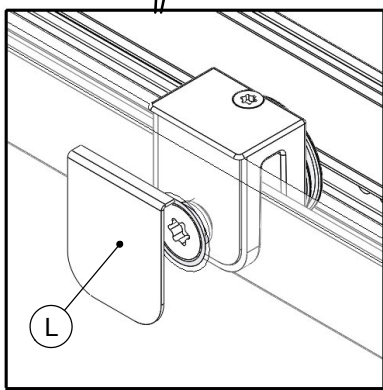
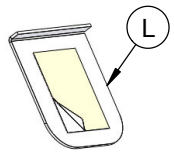
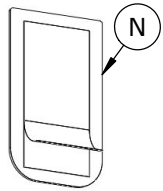
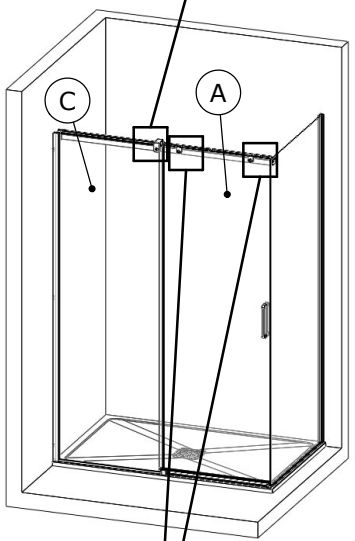
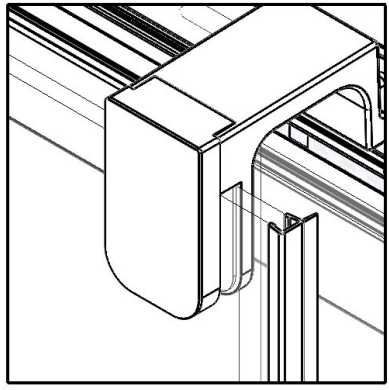
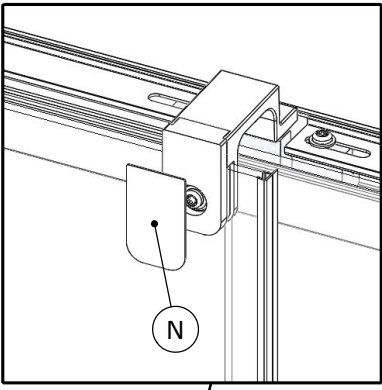

Silicone - Silicone
 Silicona - Silicón
 Silicone
 Silicone - Silikon

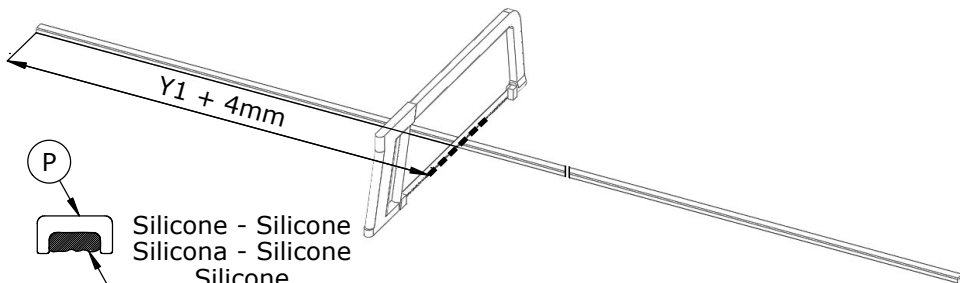
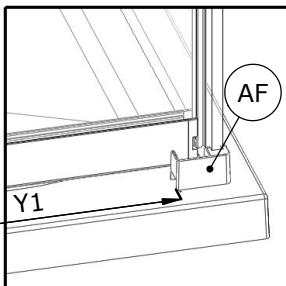
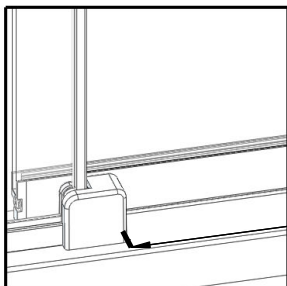
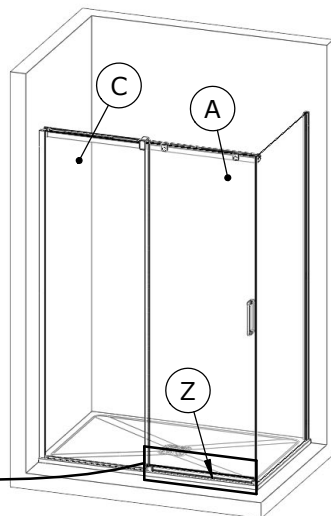
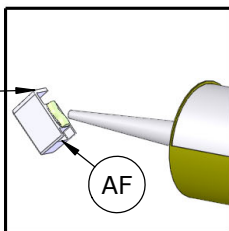
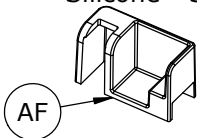

Silicone - Silicone
 Silicona - Silicón
 Silicone
 Silicone - Silikon

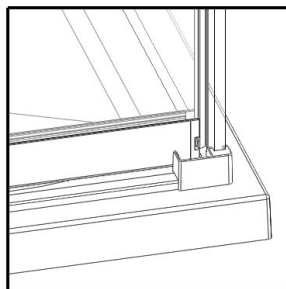
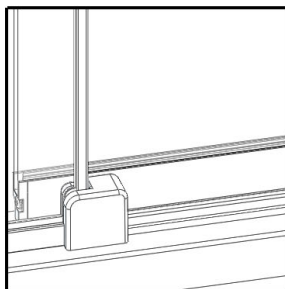
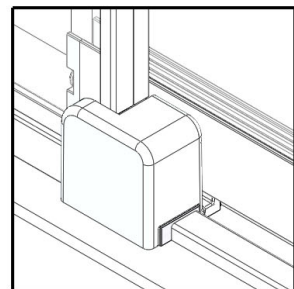
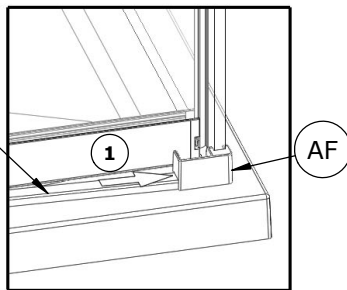
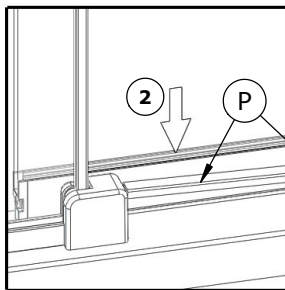
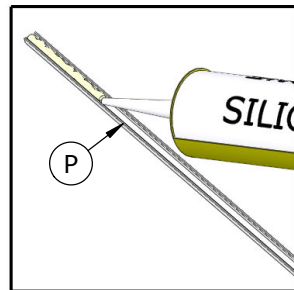

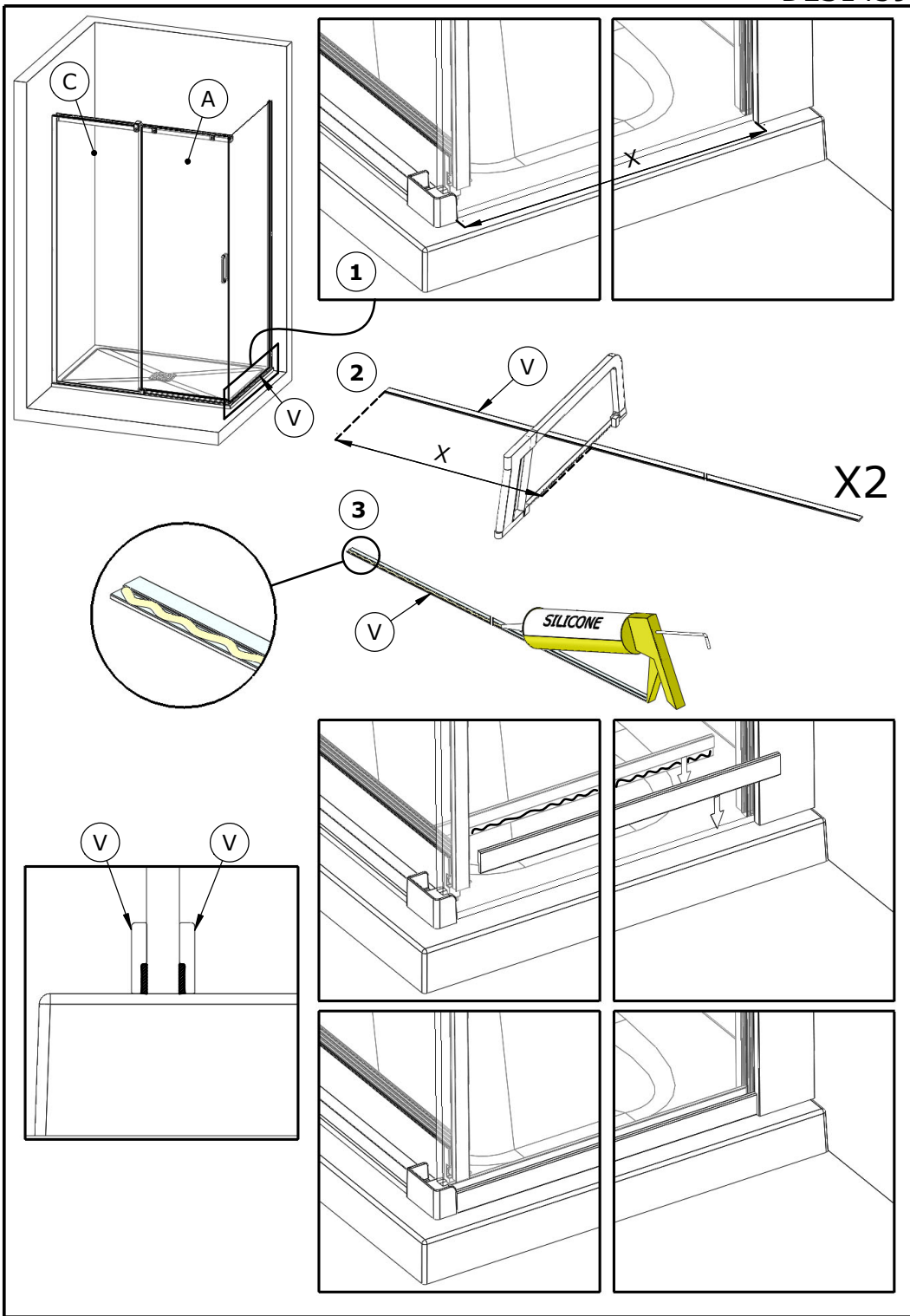

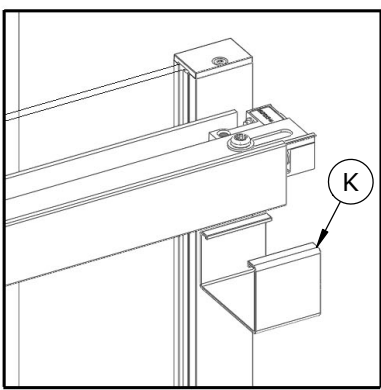
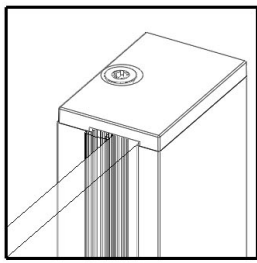
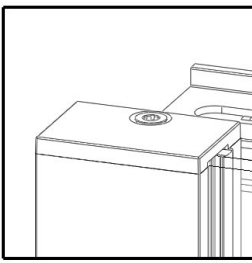
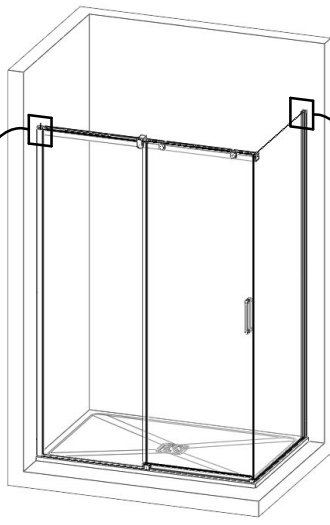
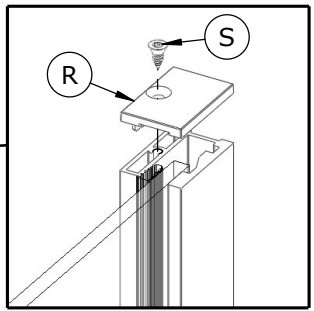
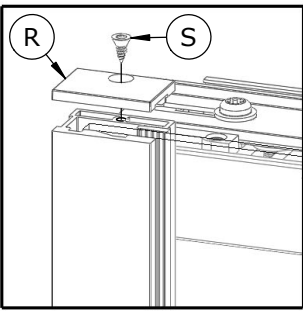

Intérieur - Inside - Interior -
Interior - Interno -
Binnenkant - Innenansicht

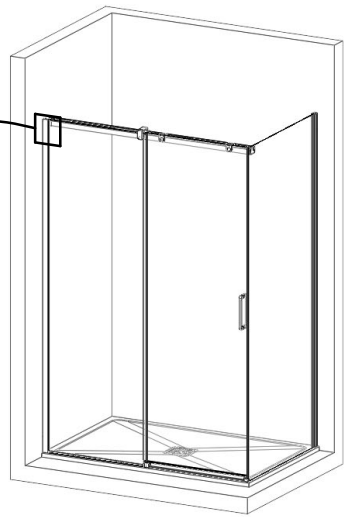
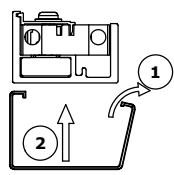
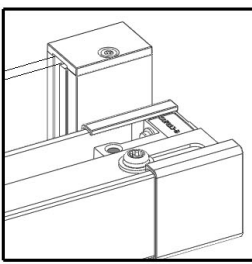

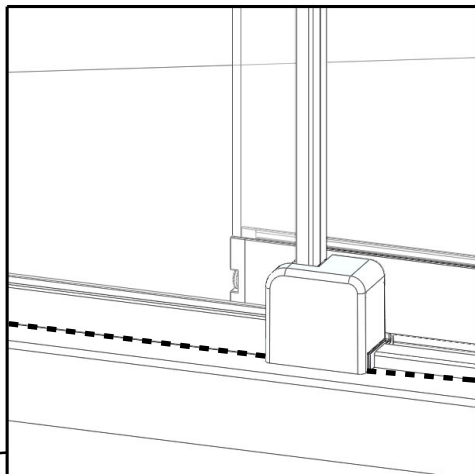
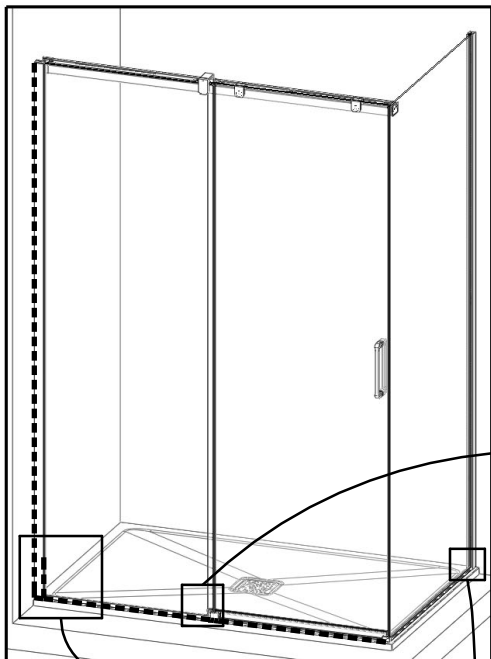

Vue extérieur - Exterior view
 Vista exterior - Vista exterior -
 vista esterna -
 Gezien van buitenaf - Außenansicht

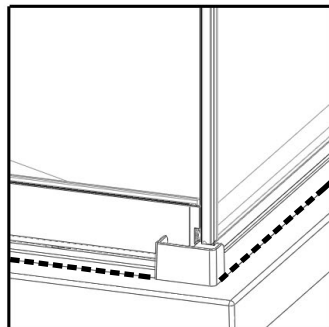
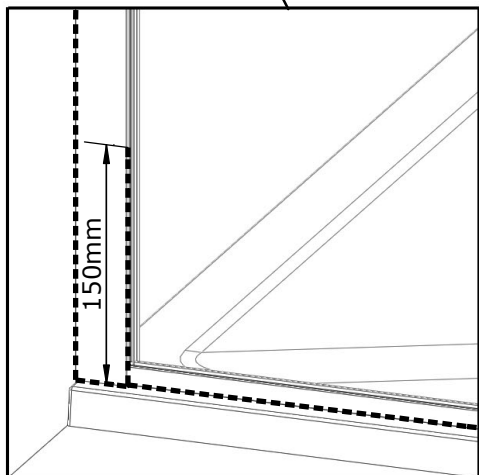
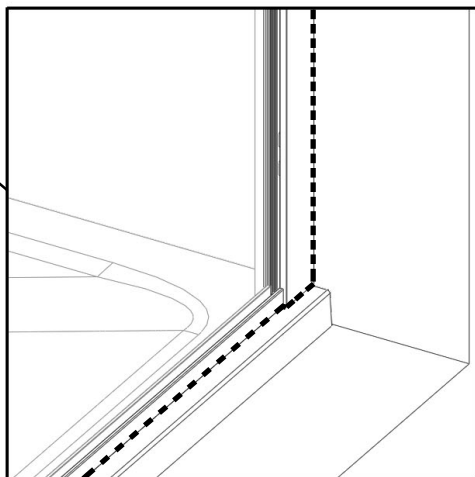

24h





<p>FR</p> <p>Bon de garantie</p> <p>SCANEZ MOI</p>  <p>http://tiny.cc/bon-de-garantie-fr</p>	<p>GB</p> <p>Guarantee</p> <p>SCAN ME</p>  <p>http://tiny.cc/bon-de-garantie-gb</p>
<p>DE</p> <p>Garantiekarte</p> <p>SCAN MICH</p>  <p>http://tiny.cc/bon-de-garantie-de</p>	<p>NL</p> <p>Garantievoorwaarden</p> <p>SCAN MIJ</p>  <p>http://tiny.cc/bon-de-garantie-nl</p>
<p>ES</p> <p>Garantía</p> <p>ESCANÉAME</p>  <p>http://tiny.cc/bon-de-garantie-es</p>	<p>IT</p> <p>Garanzia</p> <p>SCANSIONAMI</p>  <p>http://tiny.cc/bon-de-garantie-it</p>
<p>PT</p> <p>Garantia</p> <p>ESCANEEI-ME</p>  <p>http://tiny.cc/bon-de-garantie-pt</p>	<p>CH</p> <p>Garantiekarte</p> <p>SCAN MICH</p>  <p>http://tiny.cc/bon-de-garantie-ch</p>
<p>BE</p> <p>Garantievoorwaarden</p> <p>SCAN MIJ</p>  <p>http://tiny.cc/bon-de-garantie-be</p>	<p>AT</p> <p>Garantiekarte</p> <p>SCAN MICH</p>  <p>http://tiny.cc/bon-de-garantie-at</p>



Kinedo

FR

Conseils
d'entretien

SCANEZ MOI



<http://tiny.cc/conseils-entretien-fr>

GB

Maintenance
instructions

SCAN ME



<http://tiny.cc/conseils-entretien-gb>

DE

Wartungstipps

SCAN MICH



<http://tiny.cc/conseils-entretien-de>

NL

Onderhoudstips

SCAN MIJ



<http://tiny.cc/conseils-entretien-nl>

ES

Consejos de
mantenimiento

ESCANÉAME



<http://tiny.cc/conseils-entretien-es>

IT

Consigli per la
manutenzione

SCANSIONAMI



<http://tiny.cc/conseils-entretien-it>

PT

Dicas de
manutenção

ESCANEEI-ME



<http://tiny.cc/conseils-entretien-pt>

CH

Wartungstipps

SCAN MICH



<http://tiny.cc/conseils-entretien-ch>

BE

Onderhoudstips

SCAN MICH



<http://tiny.cc/conseils-entretien-be>

AT

Wartungstipps

SCAN MICH



<http://tiny.cc/conseils-entretien-at>



AQUAPRODUCTION, Site industriel,
F - 44680 Chaumes-en-Retz

20

EN 14428

Paroi de douche, fabriquée en verre de silicate
sodo-calcique de sécurité trempé thermiquement

Aptitude au nettoyage : réussite

Résistance à l'impact/propriétés de fragmentation : réussite

Durabilité : réussite



SERVICE APRÈS-VENTE AFTER-SALES SERVICE

FRANCE

+33 (0)2 40 21 29 45

UK

+44 (0)20 8842 0033

IRELAND

+353 04697 33102

DEUTSCHLAND

+49 (0) 6074 / 30928 0

ITALIA

+39 02 30559420

ÖSTEREICH

+43 1 710 60 70

SUISSE/SCHWEIZ

+41 (0)32 631 04 74

ESPAÑA

+34 93 544 60 76

NEDERLAND

+31 475 487 100

BELGIQUE/BELGIË

+31 475 487 100

РОССИЯ

+7 495 258-29-51

PORTUGAL

+351 219 112 785