

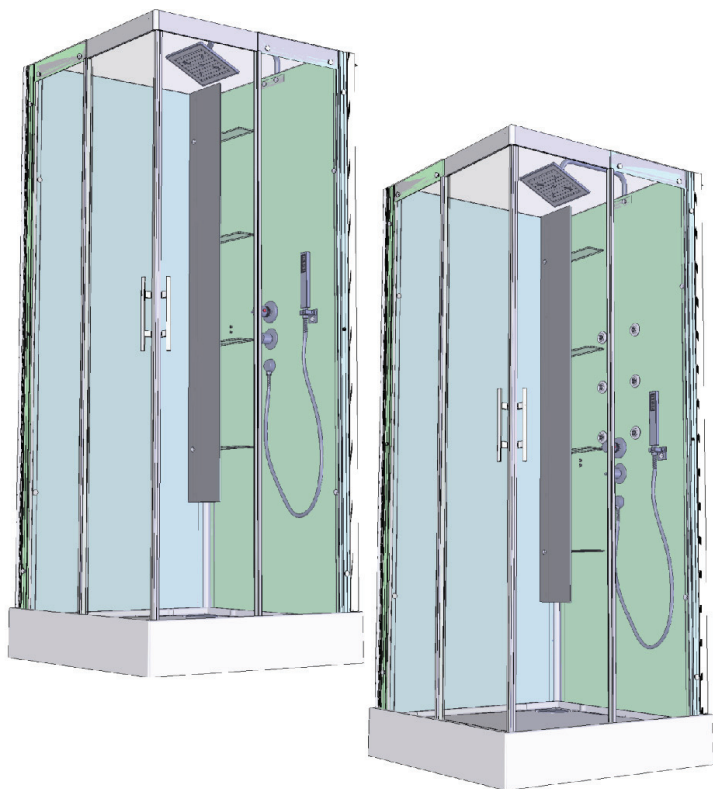

● F Notice de montage ● GB Installation instructions
● E Manual de instalación ● NL Montage-instructies







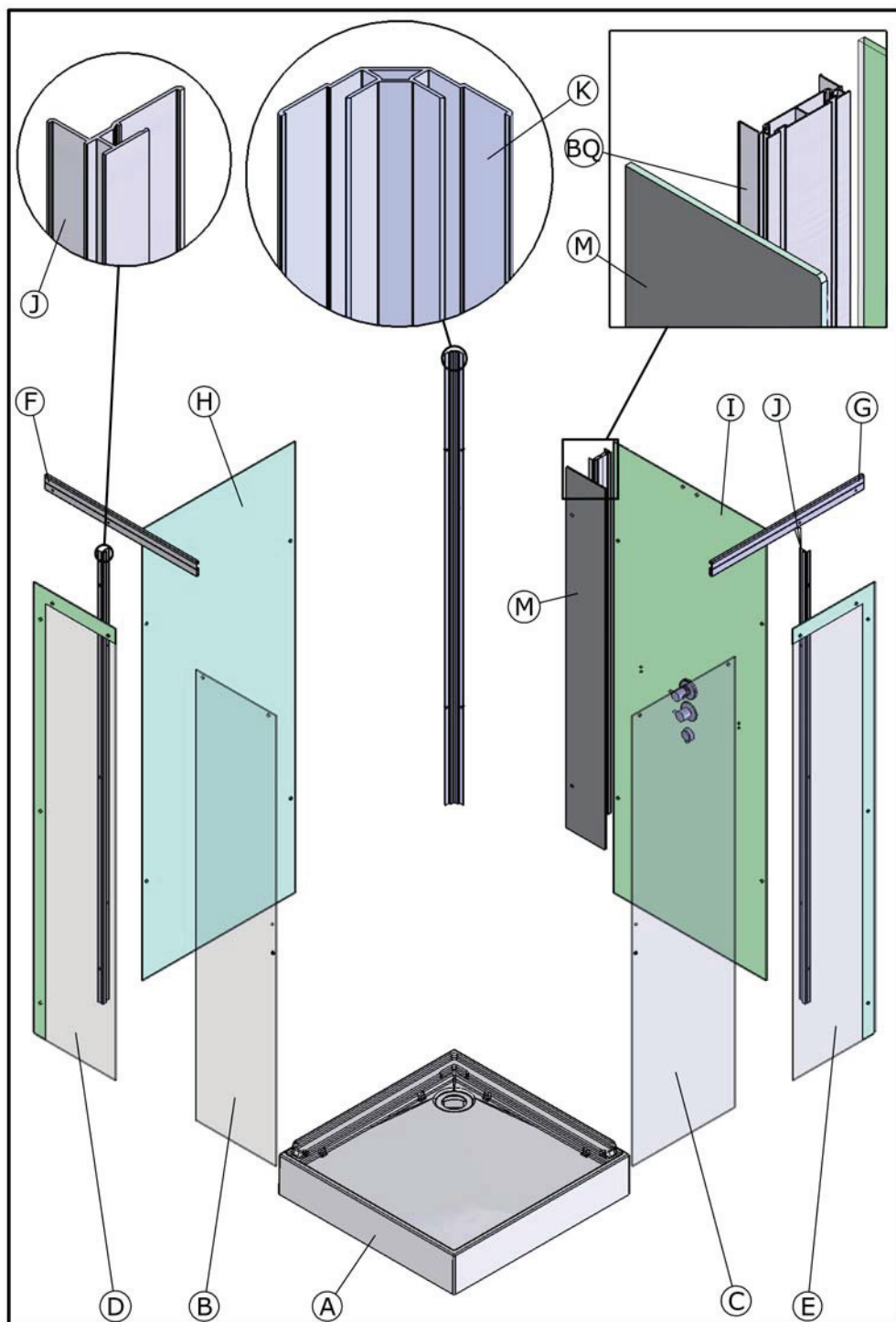

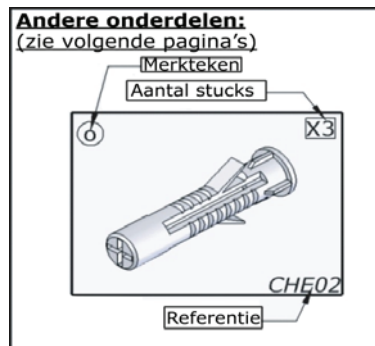
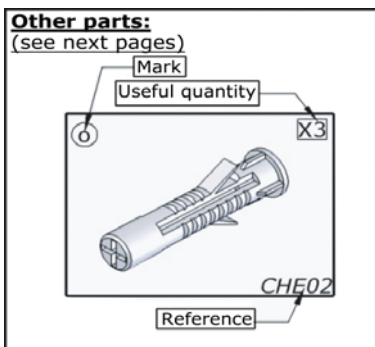
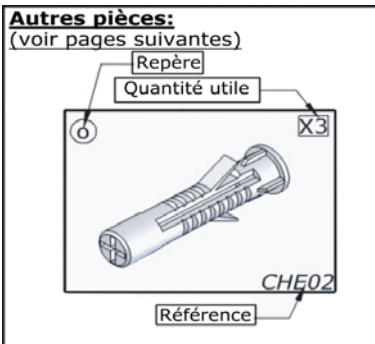

 ● F Attention aux étapes : p.10 - p.12 - p.38
● GB Check installation steps :
● E Atención a los pasos :
● NL Aandacht voor de stappen :

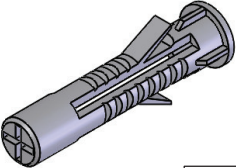
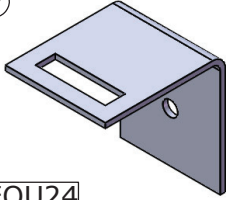
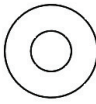
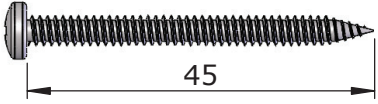
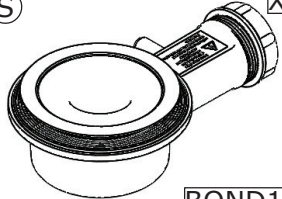

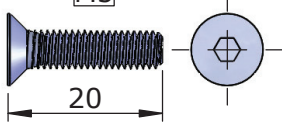

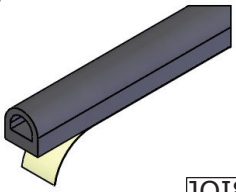

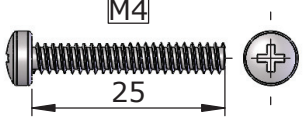

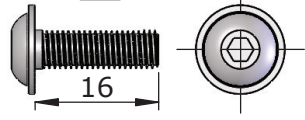
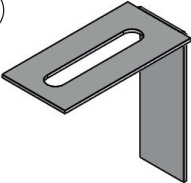
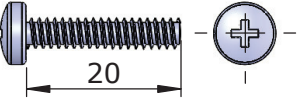
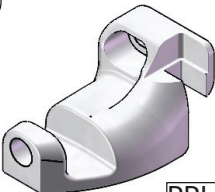
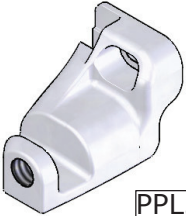

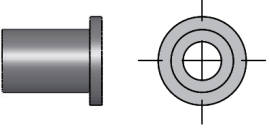
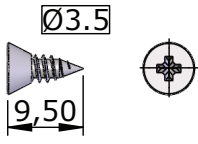

CODES COLIS (voir repères en page 2)
PACKAGE CODES (see marks on page 2)
CODIGOS BULTOS (ver marcas en paginà 2)
CODERING VERPAKKING (zie omschrijving op pagina 2)

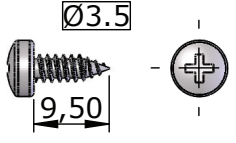
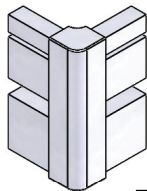
REP	VERSION	80x80	90x90	
A	H12	REC204	REC203	
	H18	REC212	REC213	
B+C		C4843E	C4841E	
D+E+M	Acier	C5075E	C5073E	
	Chrysolite	C5730E	C5746E	
	Perle Noire	C5400E	C5394E	
	Pépite	C5414E	C5415E	
	Rubis	C5398E	C5392E	
	Saphir	C5750E	C5754E	
	Flamenco Rubis	C5398E	C5392E	
	Katuko	C5400E	C5394E	
Tango	C5400E	C5394E		
F+G		5902		
H	Acier	C5077E	C5072E	
	Chrysolite	C5077E	C5072E	
	Perle Noire	C5077E	C5072E	
	Pépite	C5077E	C5072E	
	Rubis	C5077E	C5072E	
	Saphir	C5077E	C5072E	
	Flamenco Rubis	C5399E	C5393E	
	Katuko	C5403E	C5397E	
Tango	C5402E	C5396E		
I	THERMO	Acier	CP489	CP498
		Chrysolite	CP489	CP498
		Perle Noire	CP489	CP498
		Pépite	CP489	CP498
		Rubis	CP489	CP498
		Saphir	CP489	CP498
		Flamenco Rubis	CP489	CP498
		Katuko	CP305	CP303
	Tango	CP304	CP302	
	HYDRO	Acier	CP301	CP300
		Chrysolite	CP301	CP300
		Perle Noire	CP301	CP300
		Pépite	CP301	CP300
		Rubis	CP301	CP300
		Saphir	CP301	CP300
		Flamenco Rubis	CP301	CP300
Katuko		CP299	CP297	
Tango	CP298	CP296		
J		5934		
K		5933		
BQ		5901		

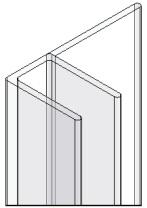

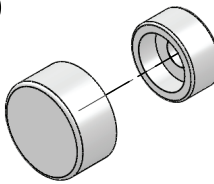

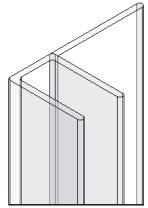
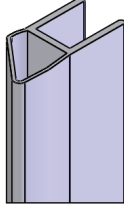
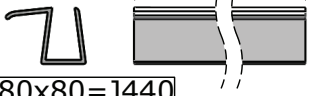
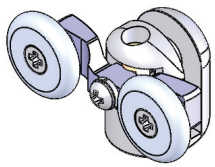
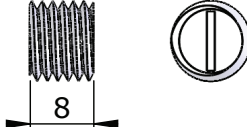
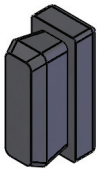



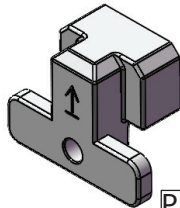
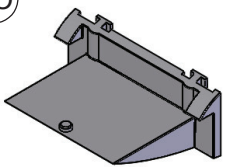
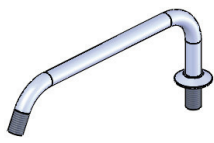
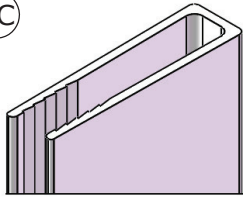
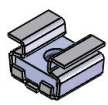
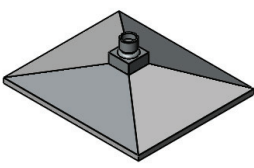

<p>○ X2</p>  <p>CHE02</p>	<p>○ X2</p>  <p>EQU24</p>	<p>○ X6</p>  <p>1=1 RON51</p>
<p>○ X2</p>  <p>1=1 VIS17</p>	<p>○ X1</p>  <p>BOND14</p>	
<p>○ X22</p>  <p>ENT19</p>	<p>○ X16</p>  <p>1=1 VIS10</p>	<p>○ X20</p>  <p>CAP07</p>
<p>○ X2</p>  <p>JOI86</p>	<p>○ X1</p>  <p>FLEX05</p>	<p>○ X2</p>  <p>1=1 VIS200</p>
<p>○ X2</p>  <p>1=1 ECR09</p>	<p>○ X4</p>  <p>1=1 VIS195</p>	<p>○ X2</p>  <p>EQU50</p>
<p>○ X2</p>  <p>1=1 VIS09</p>	<p>○ X1</p>  <p>PPL523</p>	<p>○ X1</p>  <p>PPL522</p>

DES748J

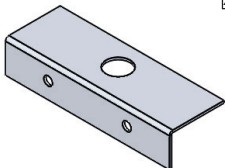
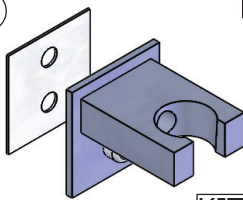
<p>(AF) X2</p>  <p>1=1 ECR14</p>	<p>(AG) X2</p>  <p>Ø3.5 9,50</p> <p>1=1 VIS22</p>	<p>(AH) X2</p>  <p>PPL520</p>
<p>(AI) X2</p>  <p>Ø3.5 9,50</p> <p>1=1 VIS01</p>	<p>(AJ) X1</p>  <p>PPL353</p>	<p>(AK) X4</p>  <p>1=1 ECR31</p>
<p>(AL) X2</p>  <p>Lq=1925mm JOI127</p>	<p>(AM) X2</p>  <p>PGN19</p>	<p>(AO) X1</p>  <p>CAC22</p>
<p>(AP) X1</p>  <p>KIT76</p>	<p>(AR) X2</p>  <p>Lq=1997mm JOI131</p>	<p>(AS) X2</p>  <p>AIM34</p>
<p>(AT) X2</p> <p>80x80=345mm 90x90=393mm</p>  <p>80x80=J440 90x90=J439</p>	<p>(AU) X4</p>  <p>ROU21</p>	<p>(AV) X2</p> <p>M10</p>  <p>8</p> <p>1=1 VIS07</p>
<p>(AW) X2</p>  <p>BUT22</p>	<p>(AX) X2</p>  <p>BUT20</p>	

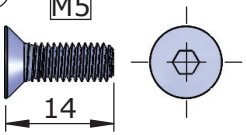
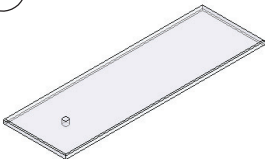
Les quantités données sont les quantités utiles au montage. Les sachets fournis contiennent des pièces supplémentaires.
The quantities given are what are required for the installation. There may be some surplus parts in the package provided.

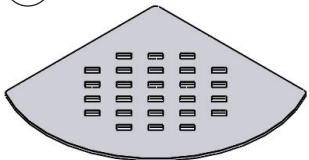
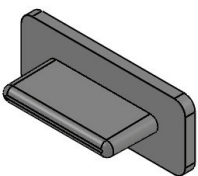
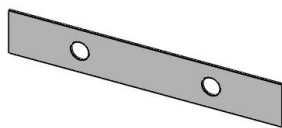
<p>(AY) X2</p>  <p>BOU37</p>	<p>(BM) X2</p>  <p>1=1 ENT12</p>	<p>(BN) X1</p>  <p>PPL550</p>
<p>(BO) X4</p>  <p>PPL756</p>	<p>(L) X1</p>  <p>KIT46</p>	<p>(BC) X2</p>  <p>PFL42</p>
<p>(BD) X2</p>  <p>ECR46</p>	<p>(N) X1</p>  <p>KIT85</p>	<p>(BG) X2</p>  <p>1=1 ECRORD</p>
<p>(BH) X1</p>  <p>TOL28</p>	<p>(BI) X1</p>  <p>KIT89</p>	<p>(BJ) X1</p>  <p>JOI16</p>
<p>(BL) X4</p>  <p>M5 14</p> <p>1=1 VIS159</p>	<p>(BR) X4</p>  <p>VER1457</p>	<p>(BS) X4</p>  <p>CAP06</p>
<p>(CB) X1</p>  <p>TOL12</p>	<p>(BT) X4</p>  <p>PPL758</p>	<p>(CD) X1</p>  <p>JOI330</p>

DES748J

Les quantités données sont les quantités utiles au montage.
Les sachets fournis contiennent des pièces supplémentaires.

The quantities given are what are required for the installation.
There may be some surplus parts in the package provided.

Las cantidades indicadas son las cantidades necesarias para el montaje.
Las bolsitas incluidas contienen piezas suplementarias.

De aangegeven hoeveelheid toont het aantal onderdelen dat voor montage nodig is.
De meegeleverde zakjes kunnen meer onderdelen bevatten.

Matériel nécessaire :
Tools required :
Material necesario :
Nodige gereedschap :

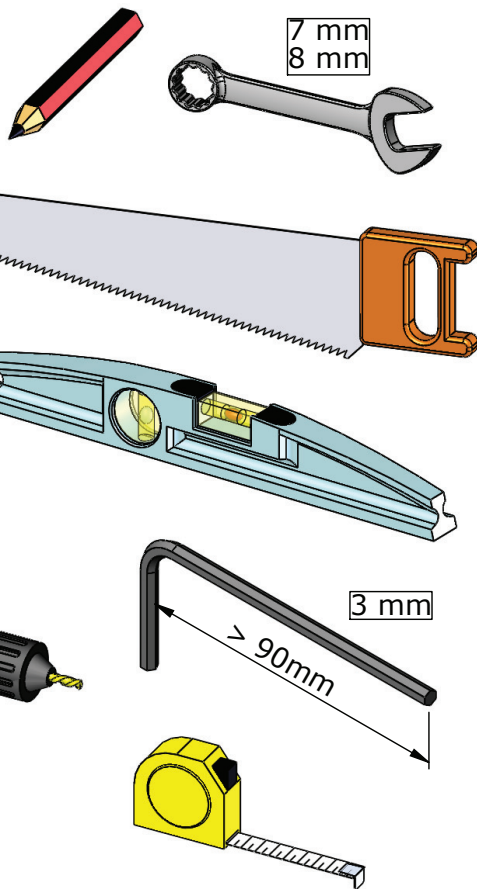

MONTAGE A DROITE
RIGHT HAND
MONTAJE A LA DERECHA
MONTAGE RECHTS

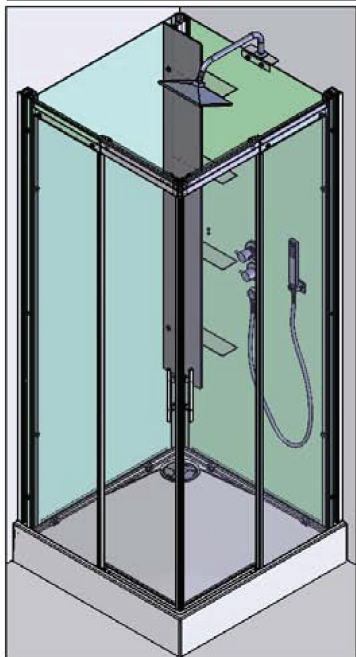

MONTAGE A GAUCHE
LEFT HAND
MONTAJE A LA IZQUIERDA
MONTAGE LINKS

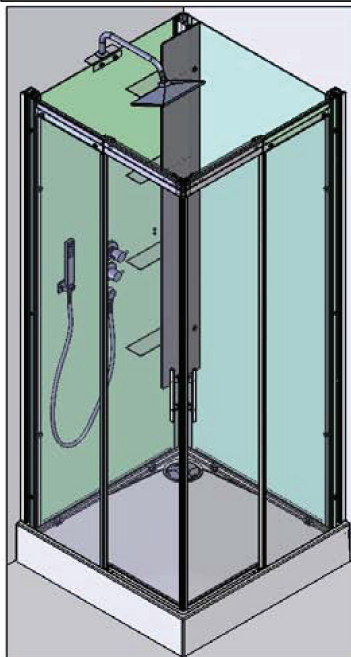

Vous avez la possibilité de réaliser un montage à droite ou un montage à gauche. Notre notice d'installation décrit un montage à droite. si vous voulez réaliser un montage à gauche, il vous suffit d'inverser le montage.

This cubicle can be installed either left or right hand. These installation instructions show a right hand installation.

Puede realizar un montaje a la derecha o un montaje a la izquierda. Nuestro folleto de instalación describe un montaje a la derecha. Si desea montar su cabina a la izquierda sólo tendrá que realizar el montaje al contrario.

U kunt de cabine rechts of links monteren. Onze handleiding beschrijft de rechtse montage van de cabine. Keer de montage om als u de cabine links wilt monteren.

01

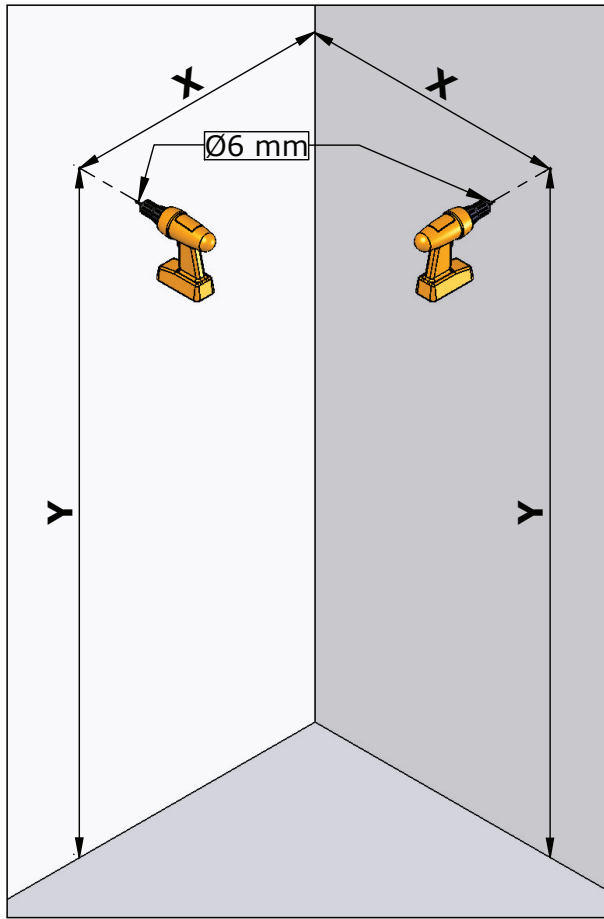

	80x80		90x90	
X	74 cm		84 cm	
Y	 12 cm 206 cm	 14.5 cm 209,5 cm	 12 cm 207 cm	 17.5 cm 212,5 cm

02

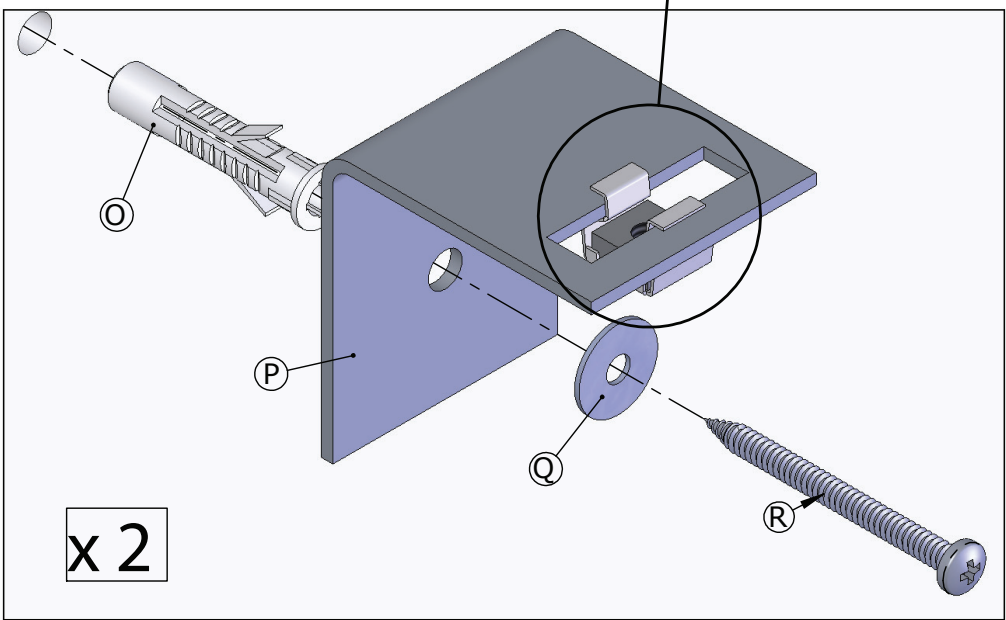
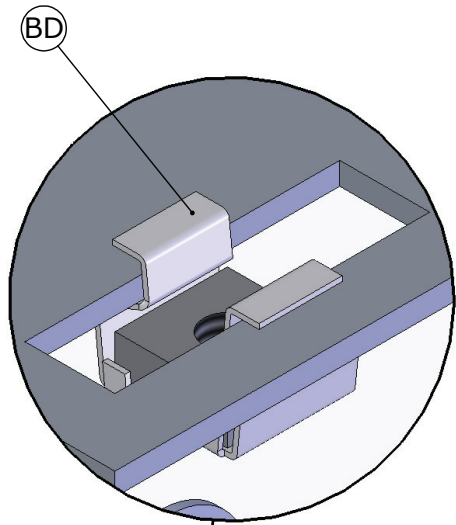

x 2

03

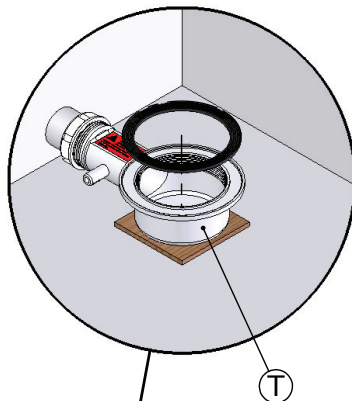
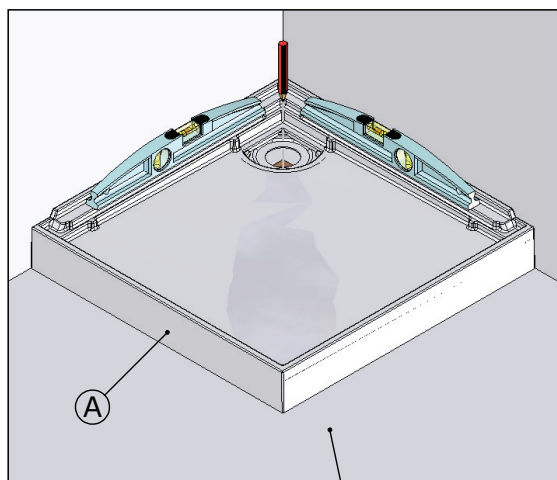

Sol rigide indispensable.
The underlying surface must be perfectly rigid.
Suelo rígido imprescindible.
De ondervloer moet volkomen vlak en stabiel zijn.

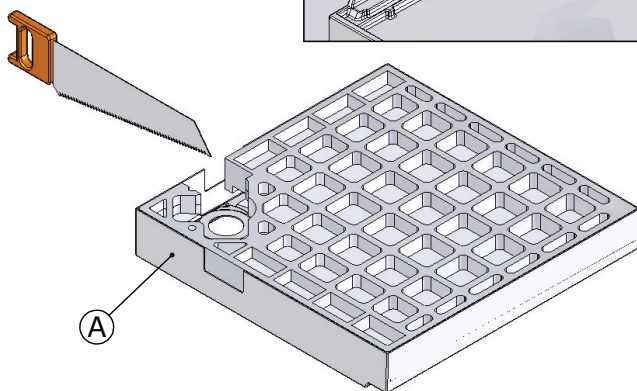
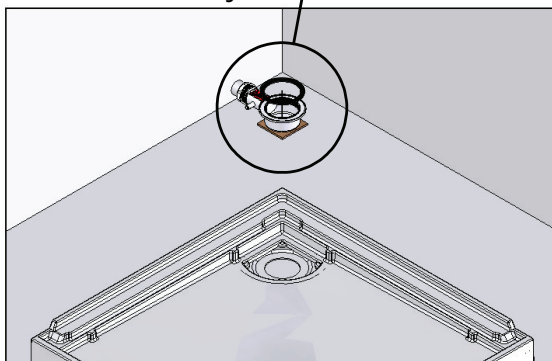

NE PAS METTRE DE COLLE ENTRE LE JOINT DE BONDE ET LE RECEVEUR.
DO NOT PUT GLUE BETWEEN THE WASTE TRAP SEAL AND THE TRAY.
NO PONER PEGAMENTO ENTRE LA JUNTA DEL DESAGÜE Y EL PLATO DE DUCHA.
GÉÉN LIJM PLAATSEN TUSSEN AFDICHTINGSRUBBER VAN DE SIFON EN DE DOUCHEBAK.

04

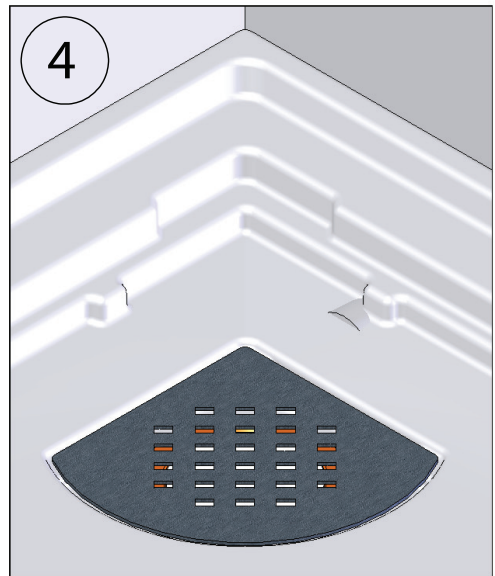
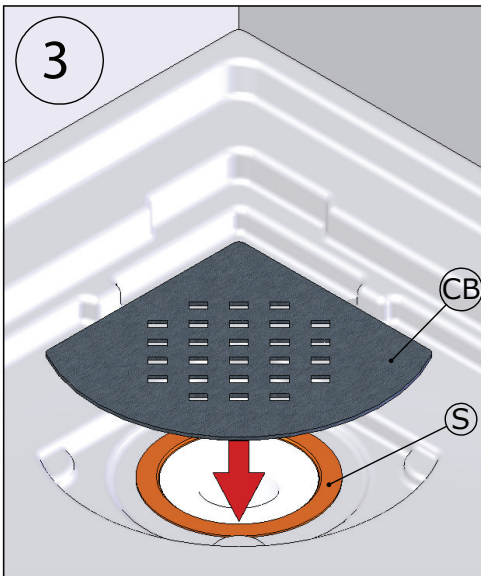
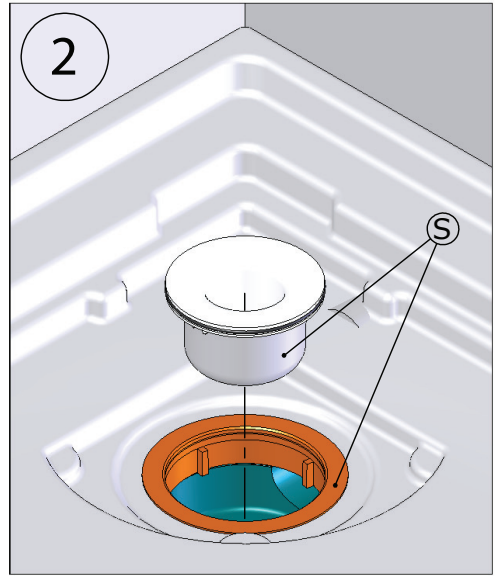
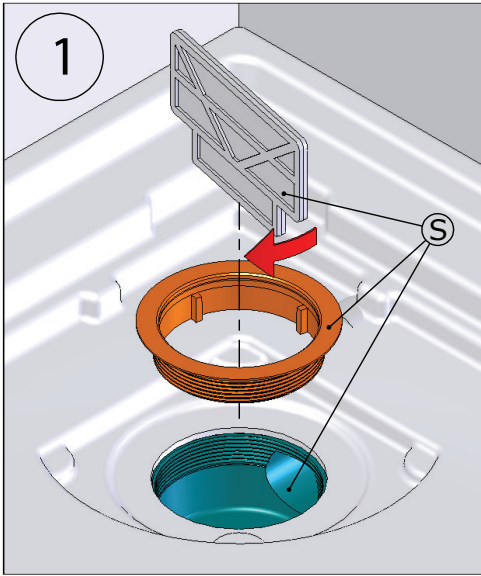

05

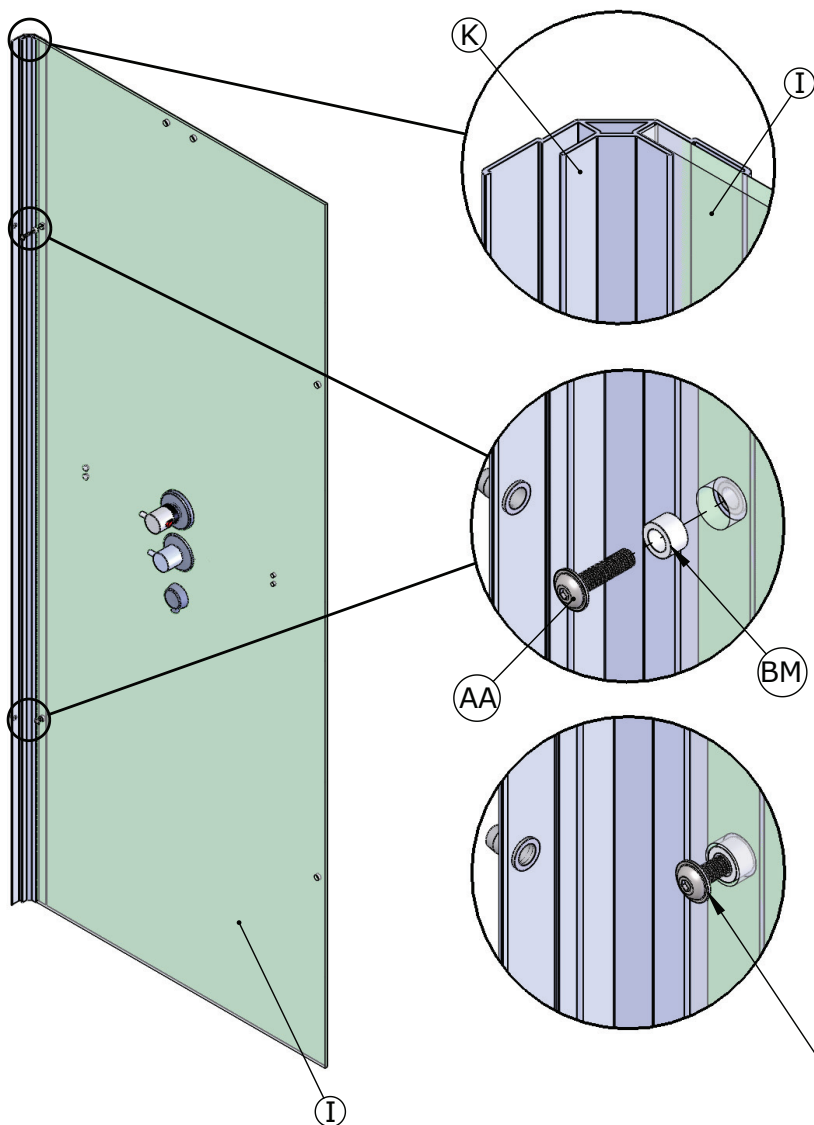

LAISSER UN JEU ENTRE LA VIS ET LE VERRE.
 LEAVE SOME PLAY FOR ADJUSTMENT.
 DEJE UN ESPACIO ENTRE EL TORNILLO Y EL CRISTAL.
 EEN DEETJE SPELLING LATEN TUSSEN DE SCHROEF EN HET GLAS.

06

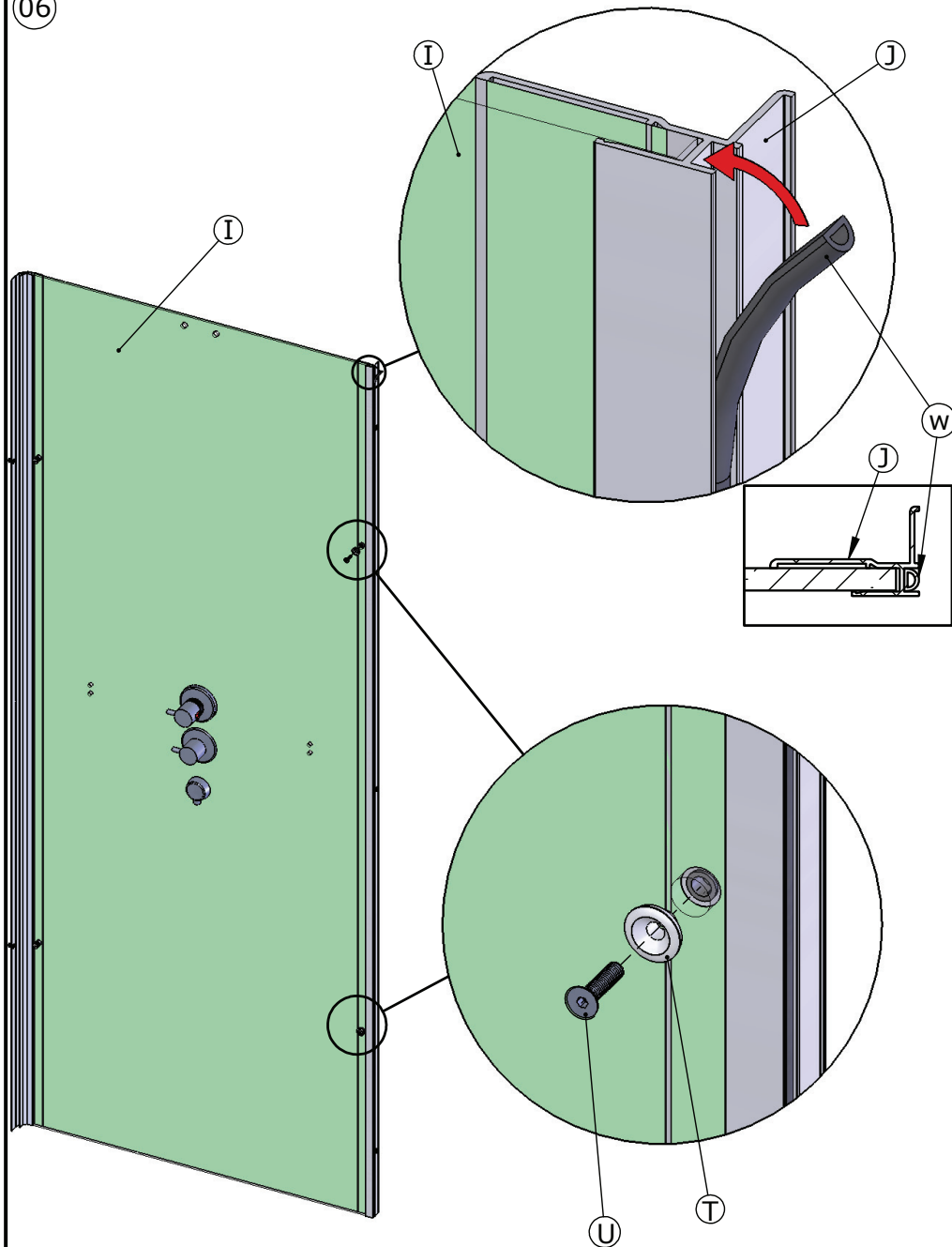

NE PAS SERRER.
DO NOT OVERTIGHTEN.
NO APRIETE.
NIET VASTSCHROEVEN.

07

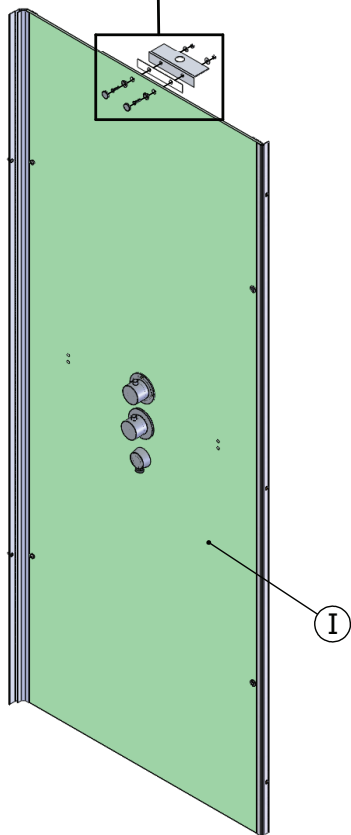
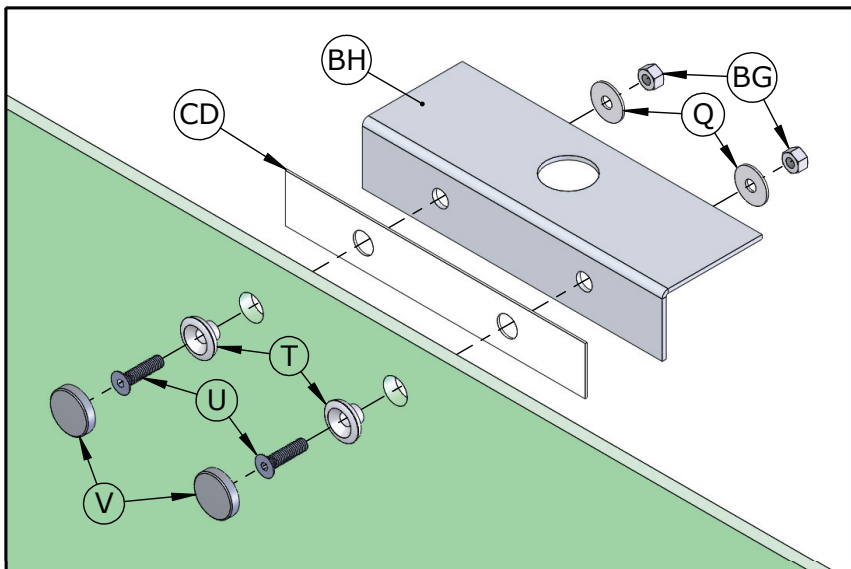

08

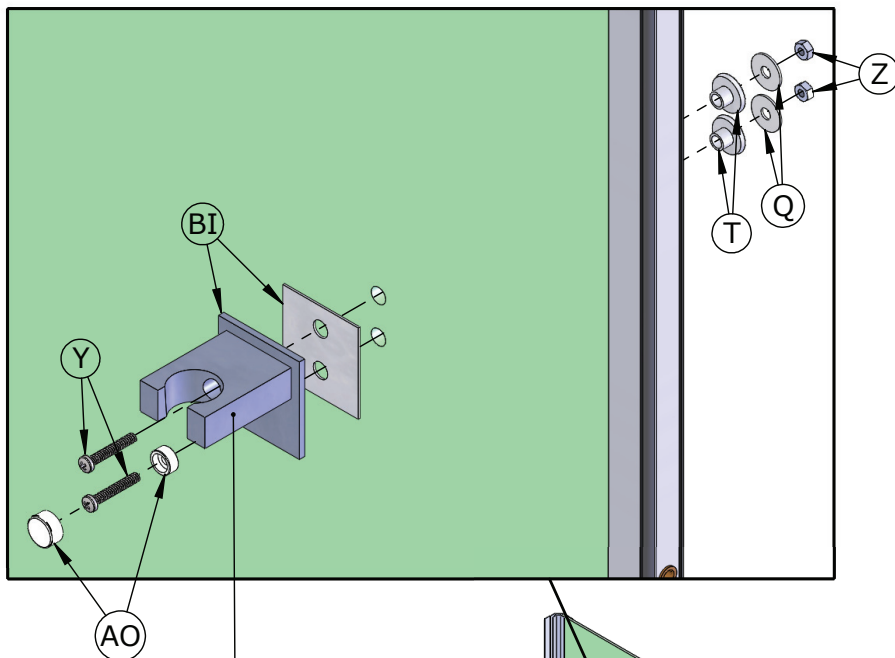

Inverser suivant le sens de montage.
Fit left or right hand depending on
installation.

Invertir según el sentido del montaje.
Invertire il senso di rotazione in base
alla direzione di montaggio.

Keer om volgens de montagerichting.
Umgekehrt entsprechend der
Einbaurichtung.

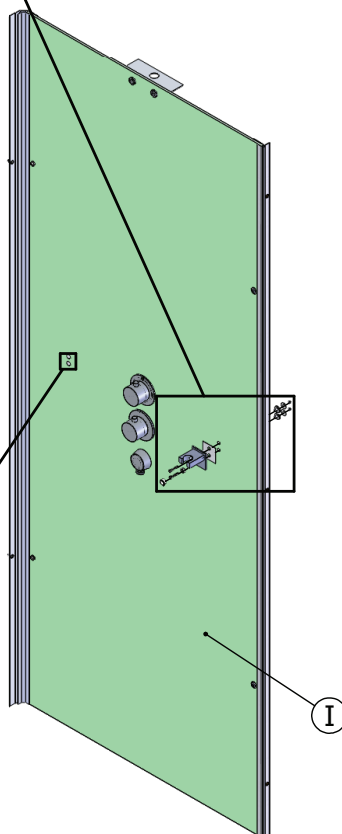
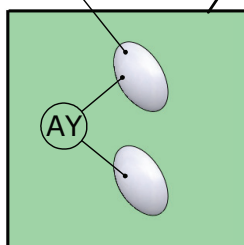

09

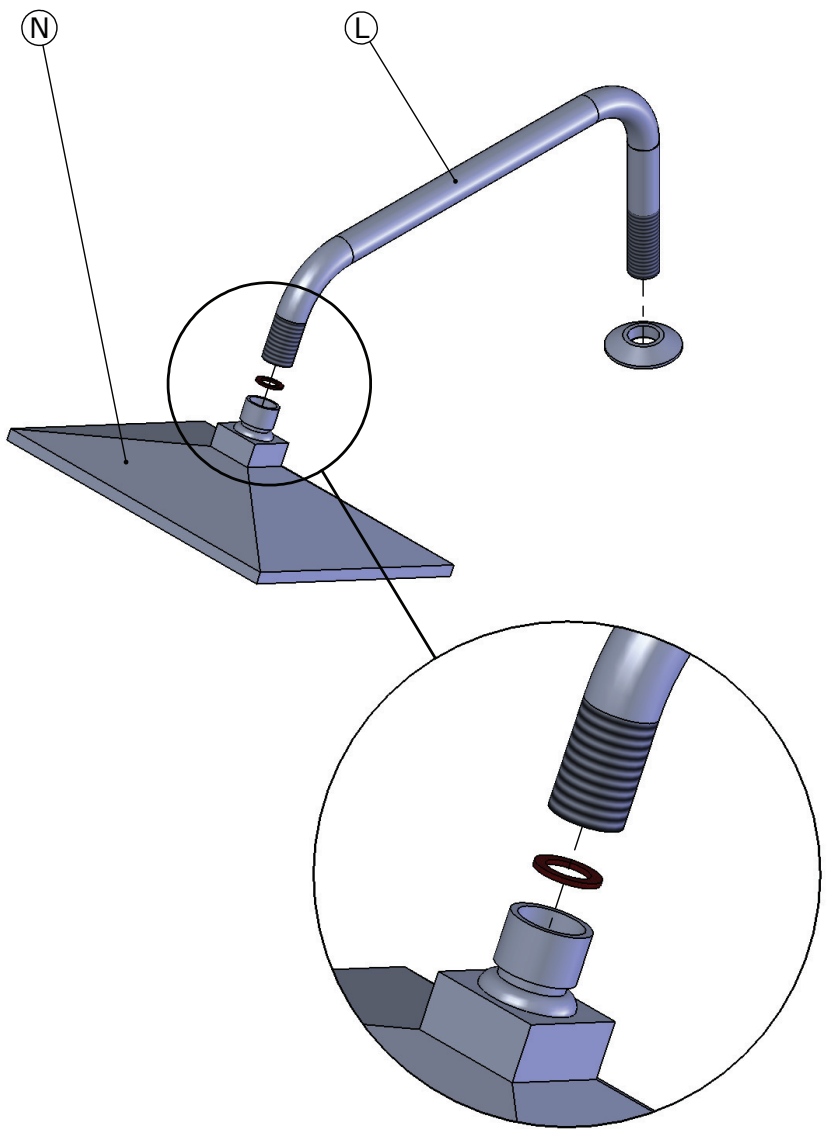

10

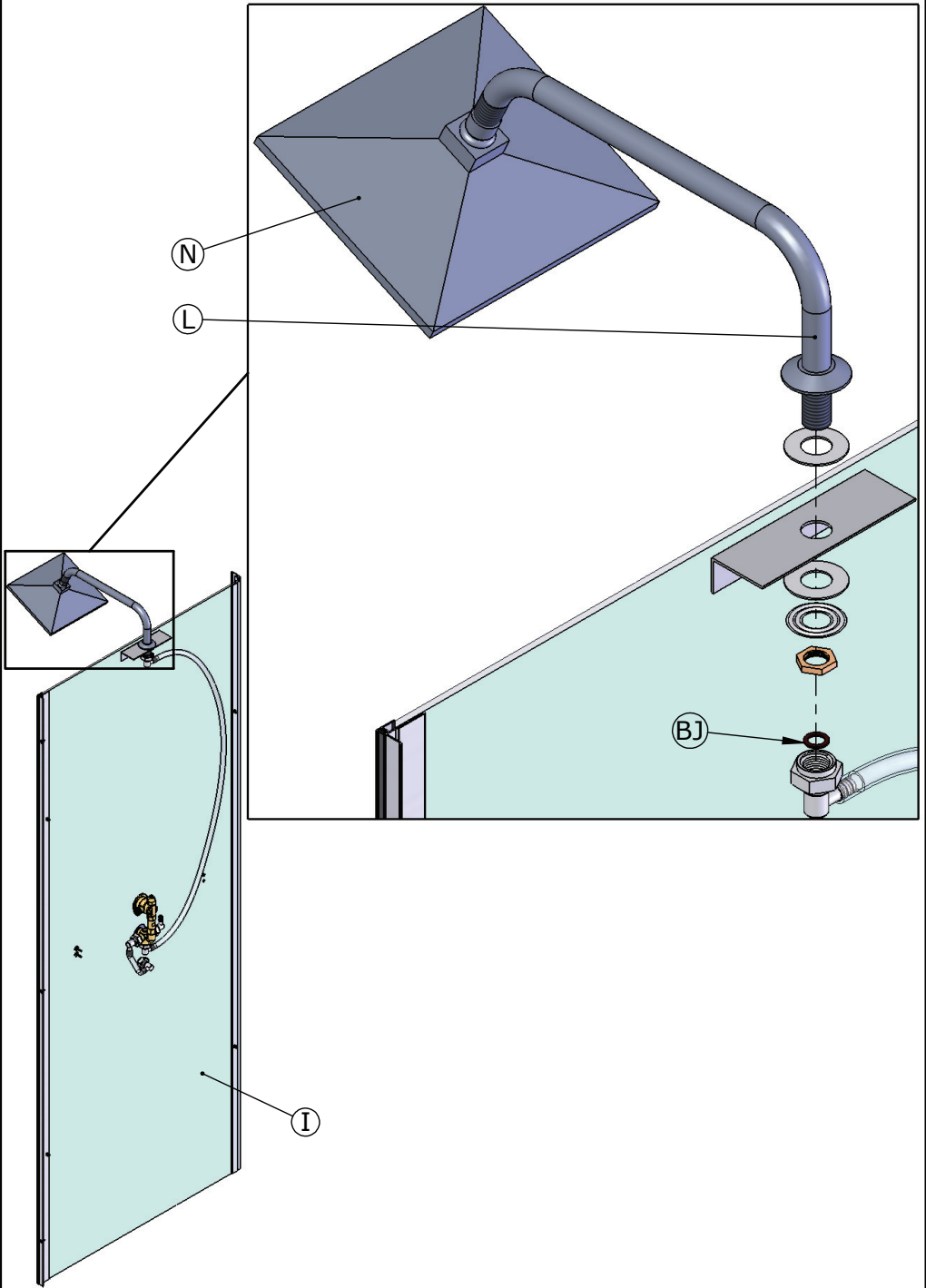

11

Sérigraphie à l'extérieur.
Screen printing on the outside.
Impresión en el fuera.
Glas-print aan buitenzijde.

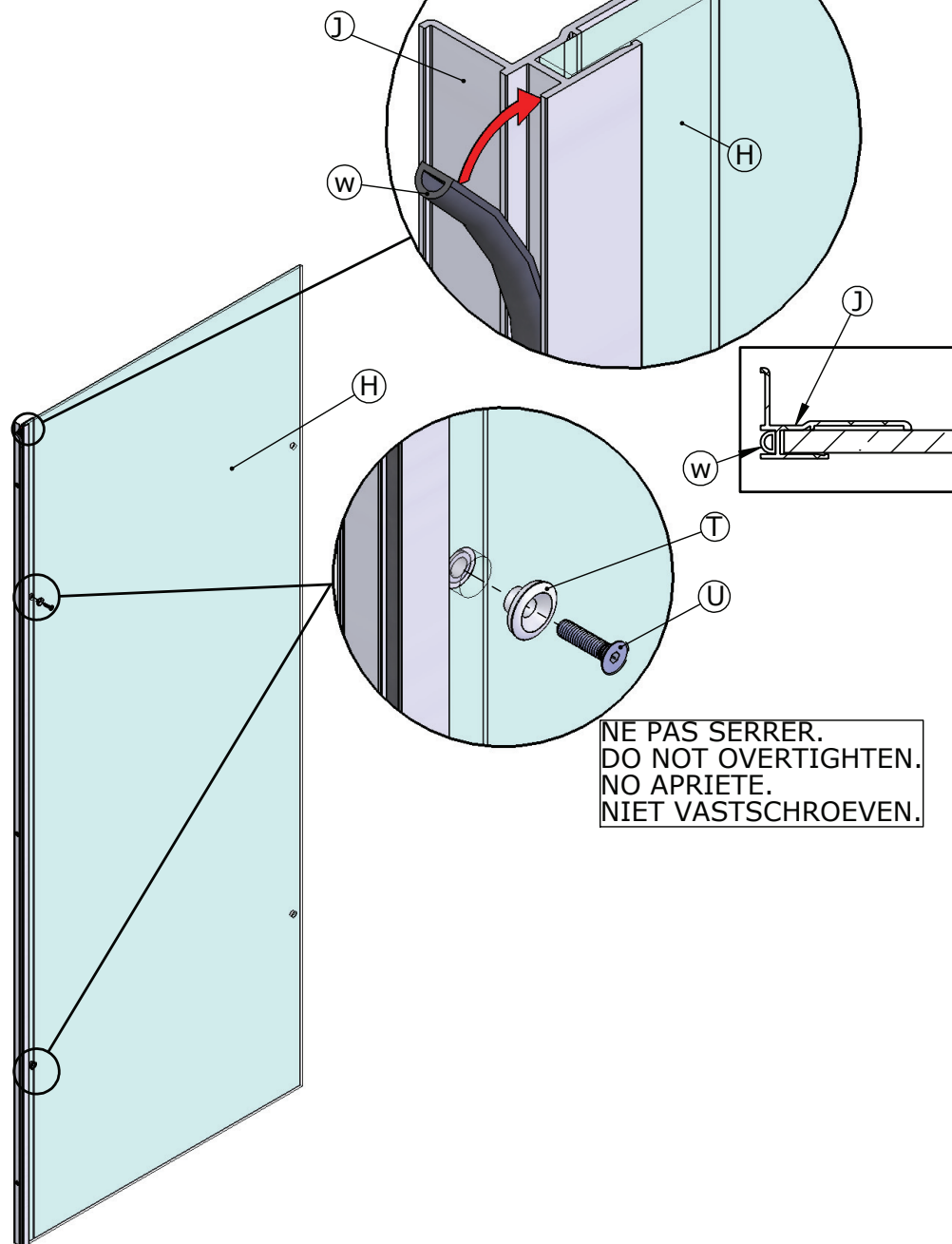

NE PAS SERRER.
DO NOT OVERTIGHTEN.
NO APRIETE.
NIET VASTSCHROEVEN.

12

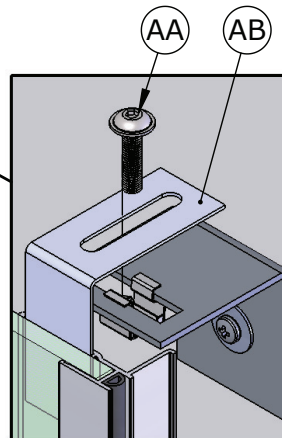
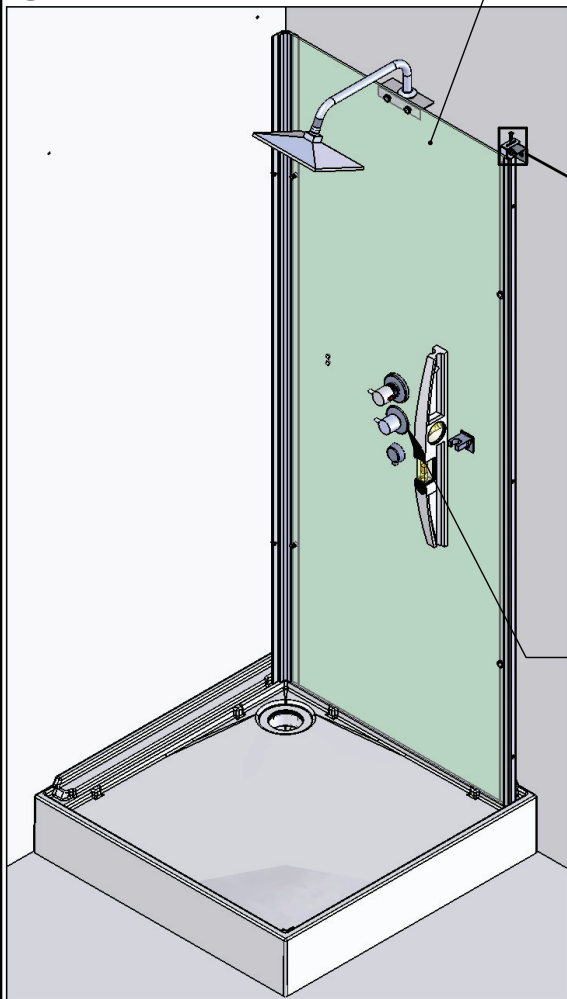

NE PAS SERRER.
DO NOT OVERTIGHTEN.
NO APRIETE.
NIET VASTSCHROEVEN.

CONNECTER L'ARRIVÉE D'EAU
ET LA LIAISON
EQUIPOTENTIELLE.
CONNECT THE WATER SUPPLY
AND CHECK FOR LEAKS AT
THIS POINT AND CONNECT
EARTH CONNECTOR.
CONECTE LA ENTRADA DE
AGUA Y LA CONEXION
EQUIPOTENCIAL.
SLUIT DE WATERTOEVOER EN
DE
EQUIPOTENTIALVERBINDING
AAN.

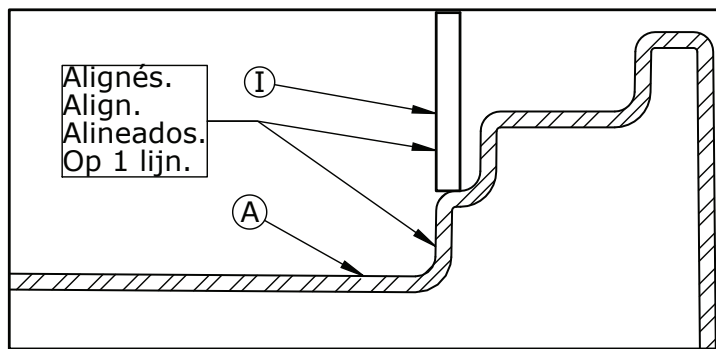

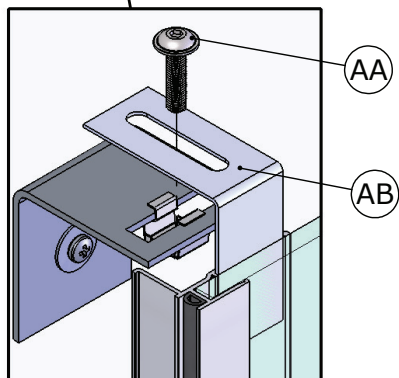
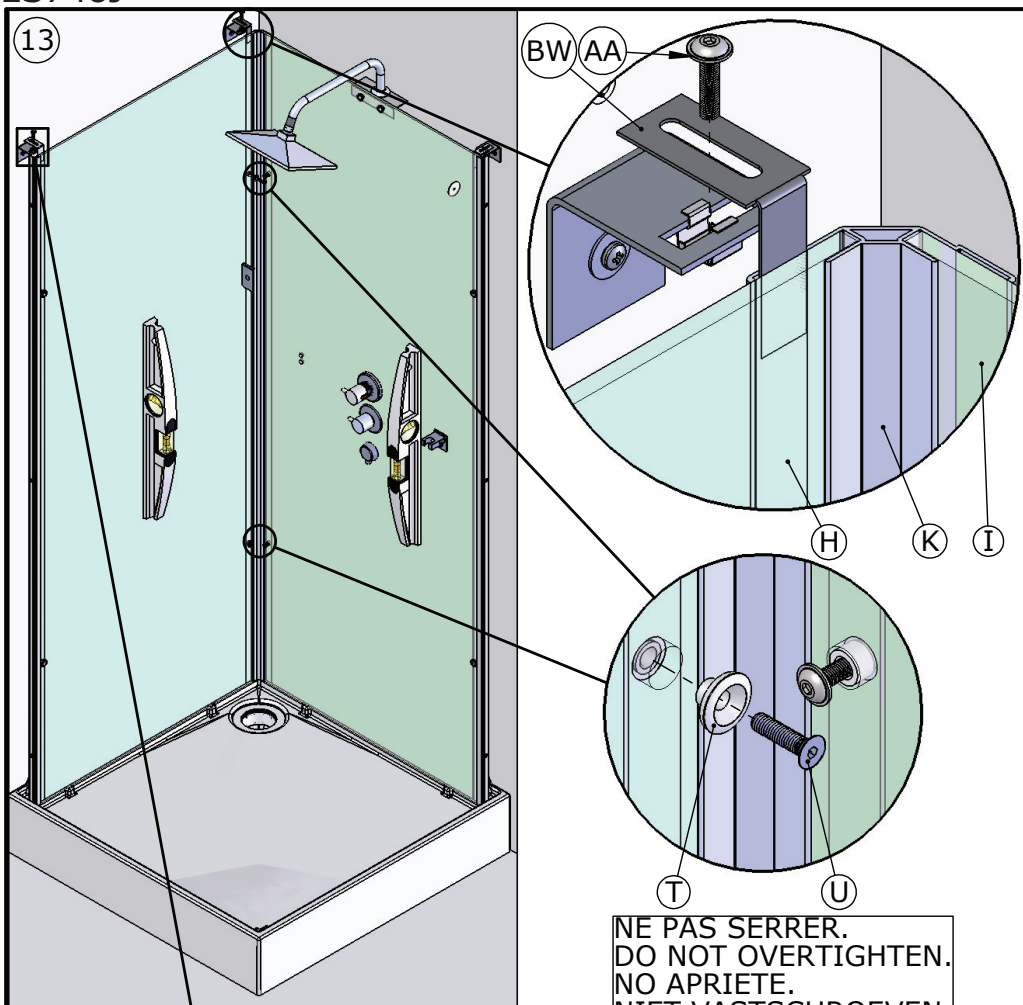

NE PAS SERRER.
DO NOT OVERTIGHTEN.
NO APRIETE.
NIET VASTSCHROEVEN.

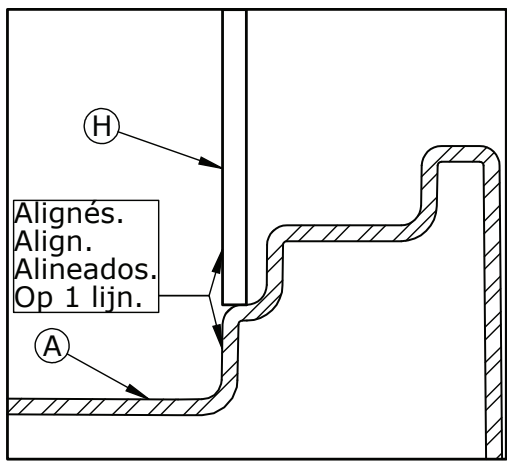

14

Sérigraphie à l'intérieur.
Screen printing on the inside.
Impresión en el interior.
Bedrukking aan de binnenzijde.

Perçages en haut.
Drill holes on top.
Perforaciones en la parte superior.
Gaatjes bovenaan.

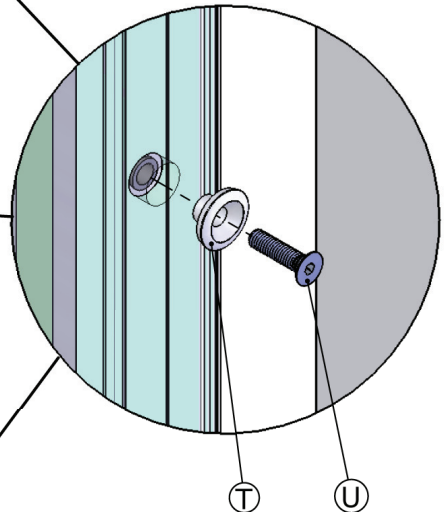
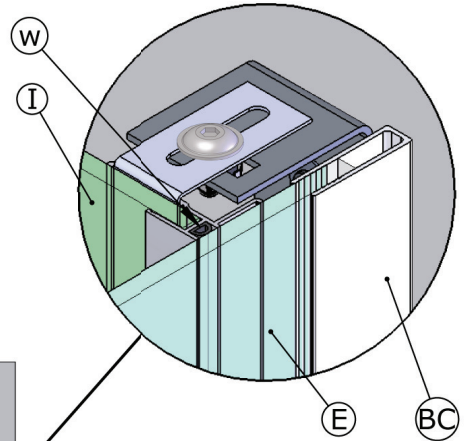
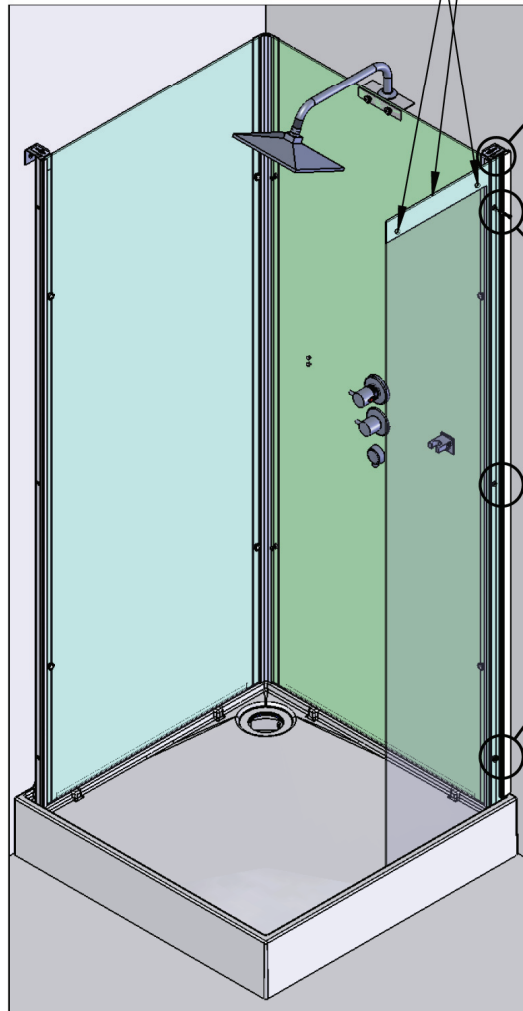

NE PAS SERRER.
DO NOT OVERTIGHTEN.
NO APRIETE.
NIET VASTSCHROEVEN.

15

Sérigraphie à l'intérieur.
Screen printing on the inside.
Impresión en el interior.
Bedrukking aan de binnenzijde.

Perçages en haut.
Drill holes on top.
Perforaciones en la parte superior.
Gaatjes bovenaan.

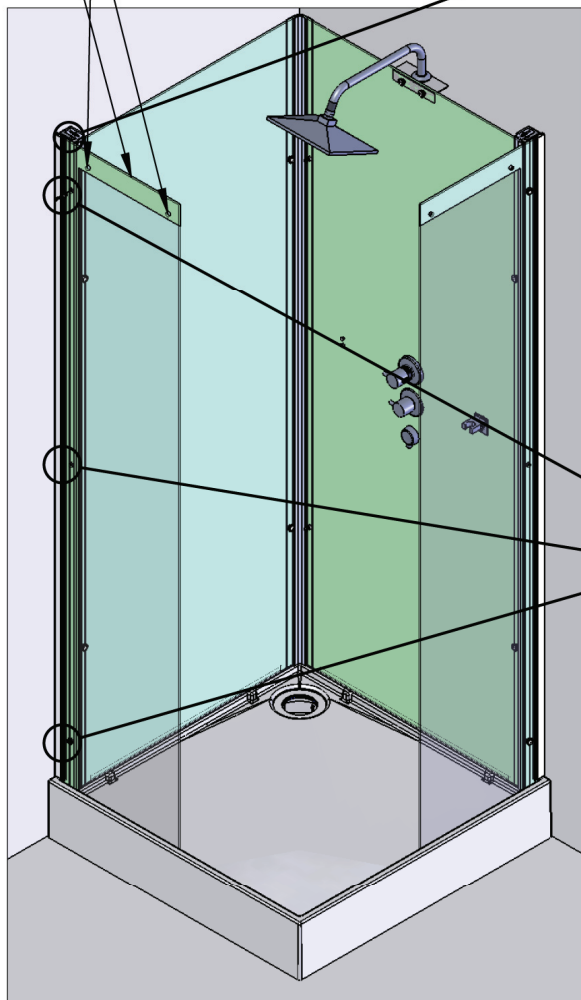

BC

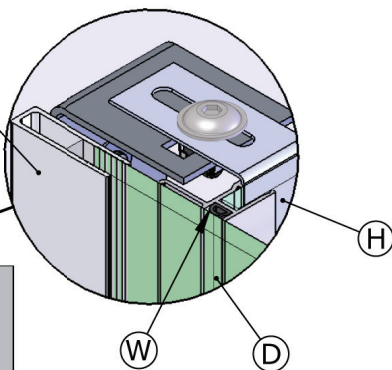

H

W

D

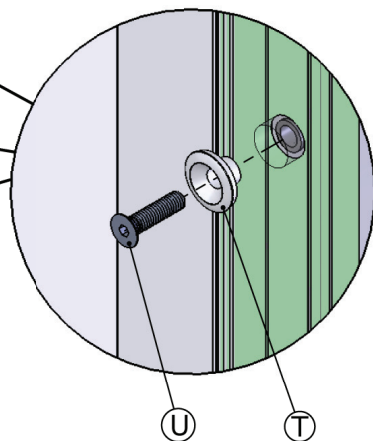

U

T

NE PAS SERRER.
DO NOT OVERTIGHTEN.
NO APRIETE.
NIET VASTSCHROEVEN.

16

Gabarit de positionnement
 Template for the correct positioning
 Plantilla de posicionamiento

Ø8 mm

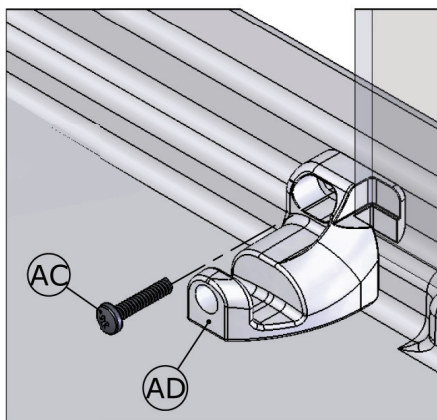
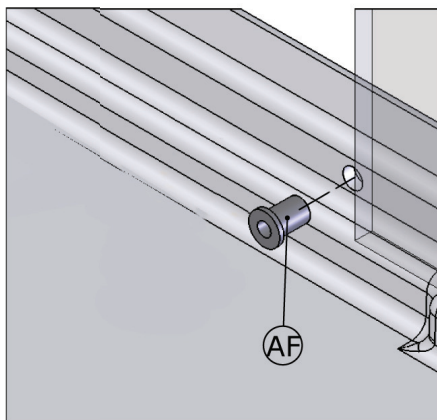
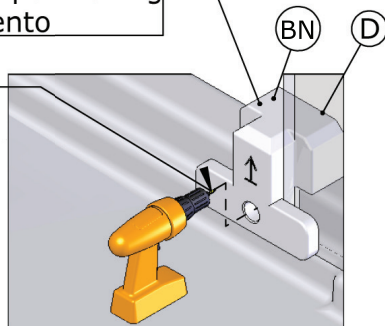
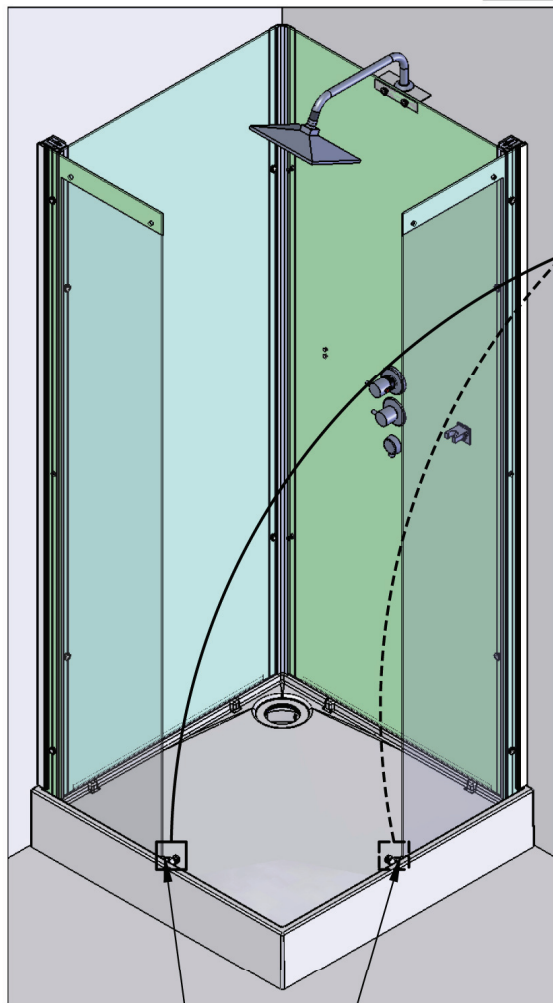

Assurer vous du bon positionnement
 des verres avant de percer.
 Ensure glass panels are fully home
 before drilling.

17

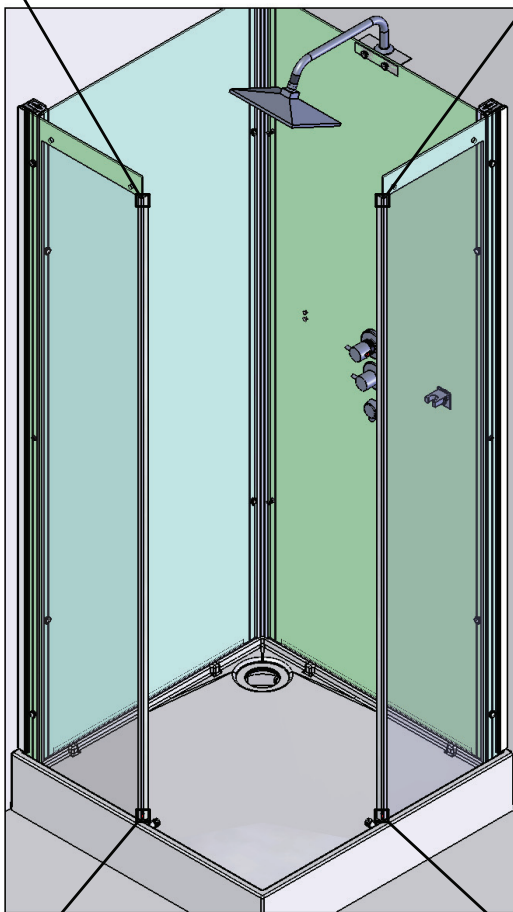
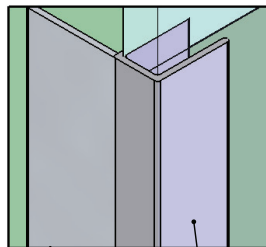
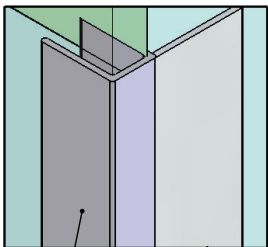

AL

AL

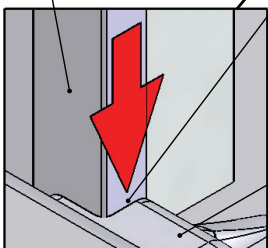

AD

Positionner les joints (AL) en buté dans les guides (AD) et (AE).
 Position the edge (AL) within the guides (AD) and (AE).
 Coloque las juntas (AL) introduciéndolas en las guías (AD) y (AE).
 Plaats de afsluitingen (AL) tussen de geleiders (AD) en (AE).

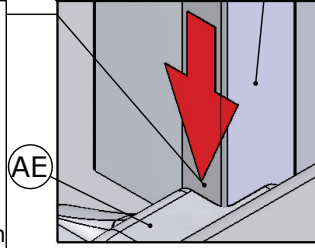

AE

18

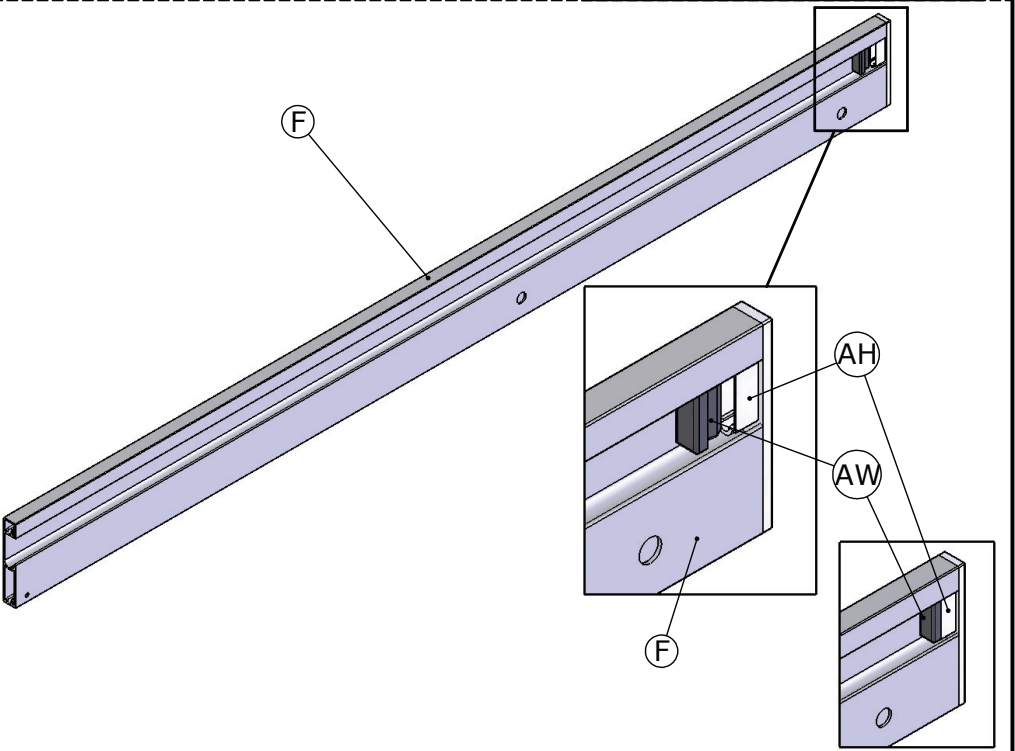
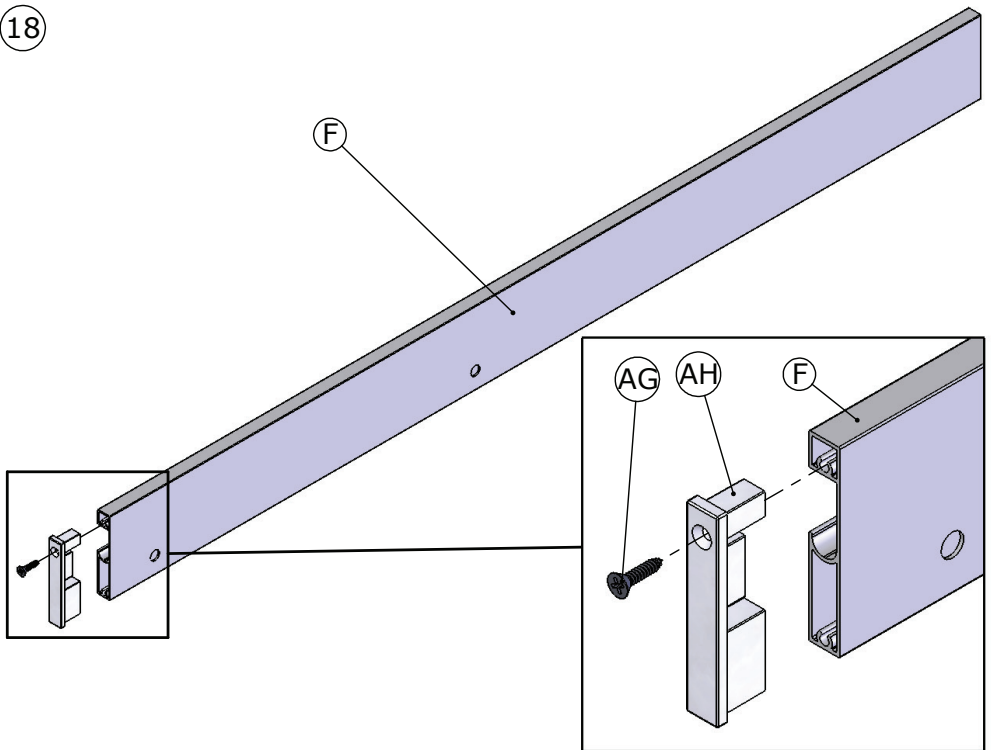

19

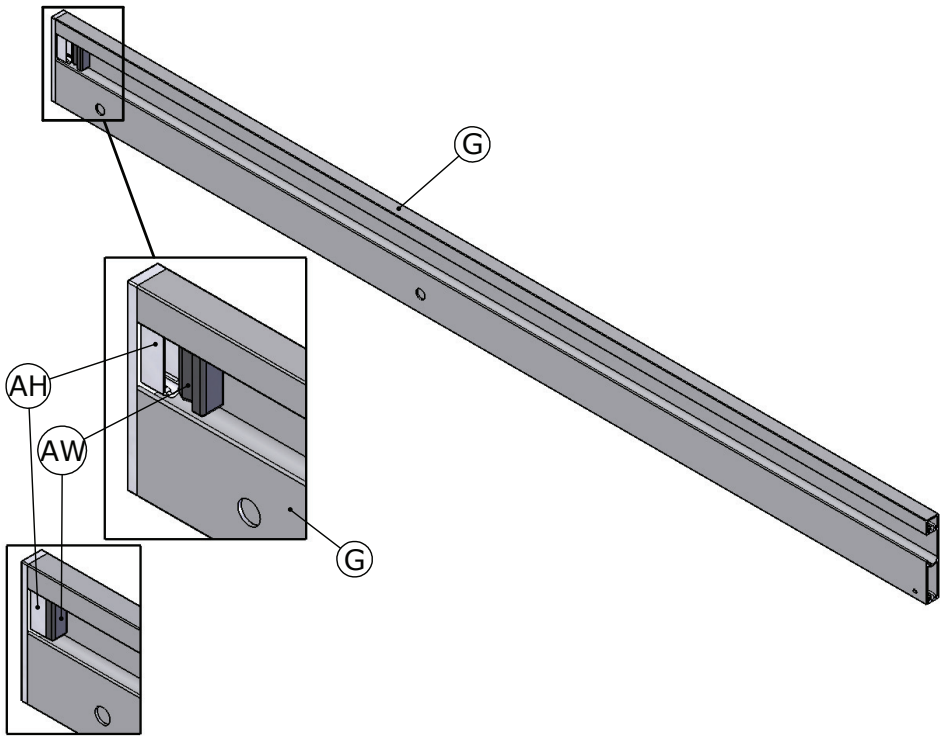
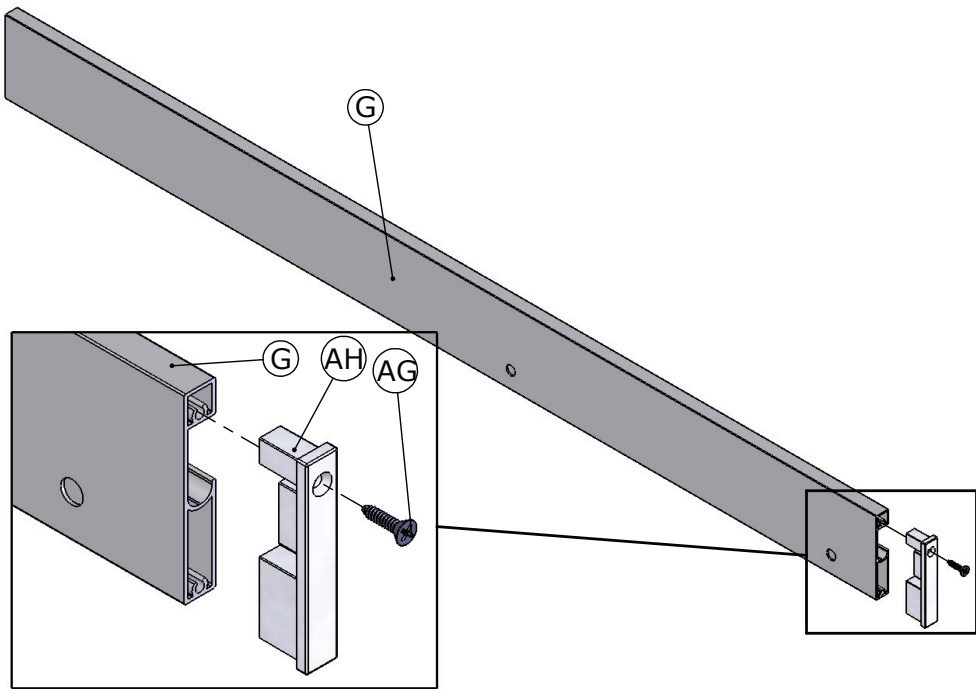

20

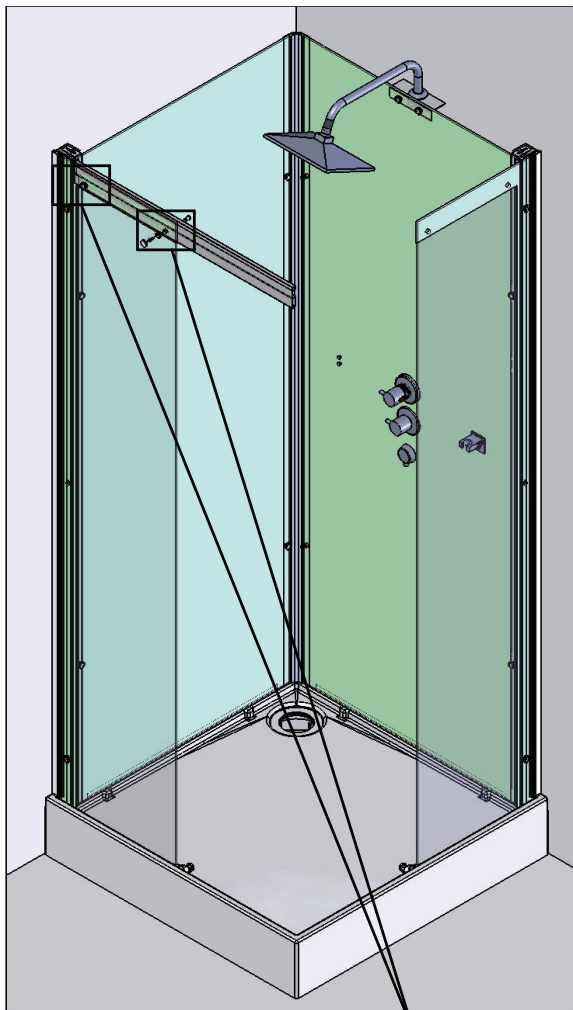

(F) est à l'intérieur
de la douche.
(F) is inside the
shower.
(F) está en el interior
de la ducha.
(F) zit aan de
binnenzijde van de
douche.

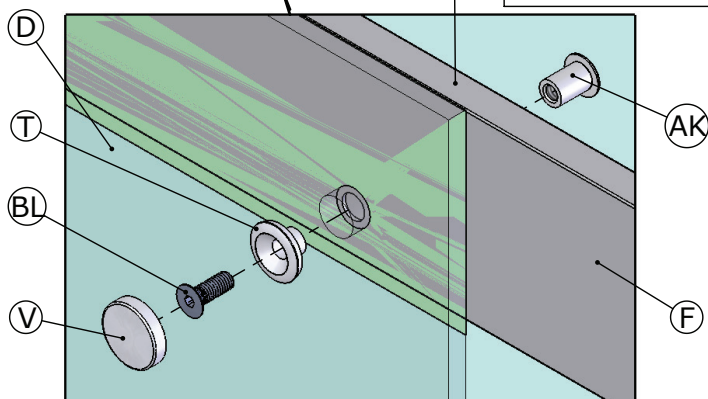

21

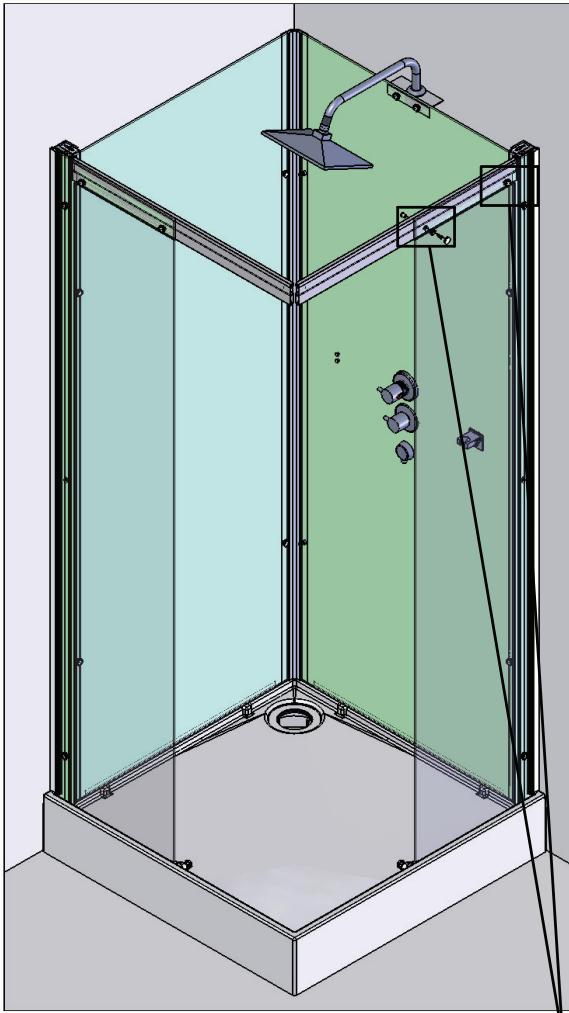

(G) est à l'intérieur
de la douche.
(G) is inside the
shower.
(G) está en el
interior de la ducha.
(G) zit aan de
binnenzijde van de
douche.

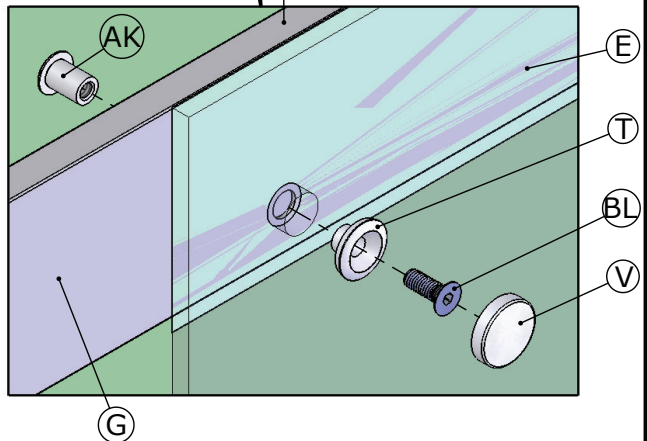

22

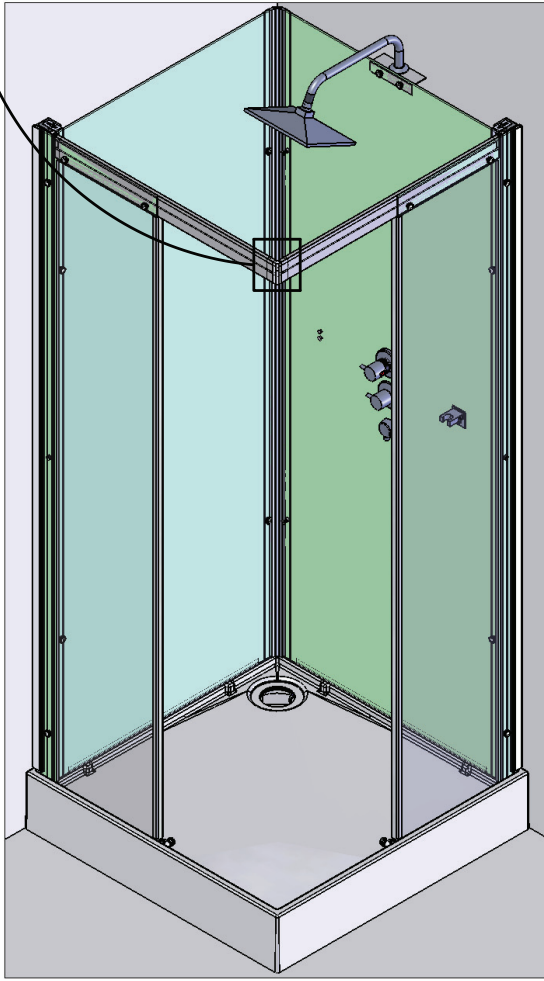
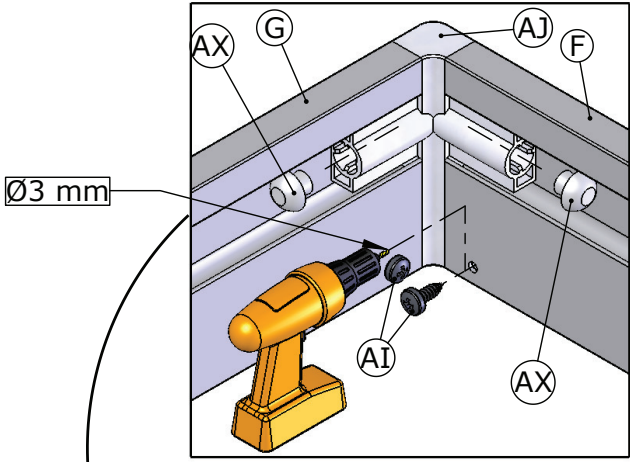

23

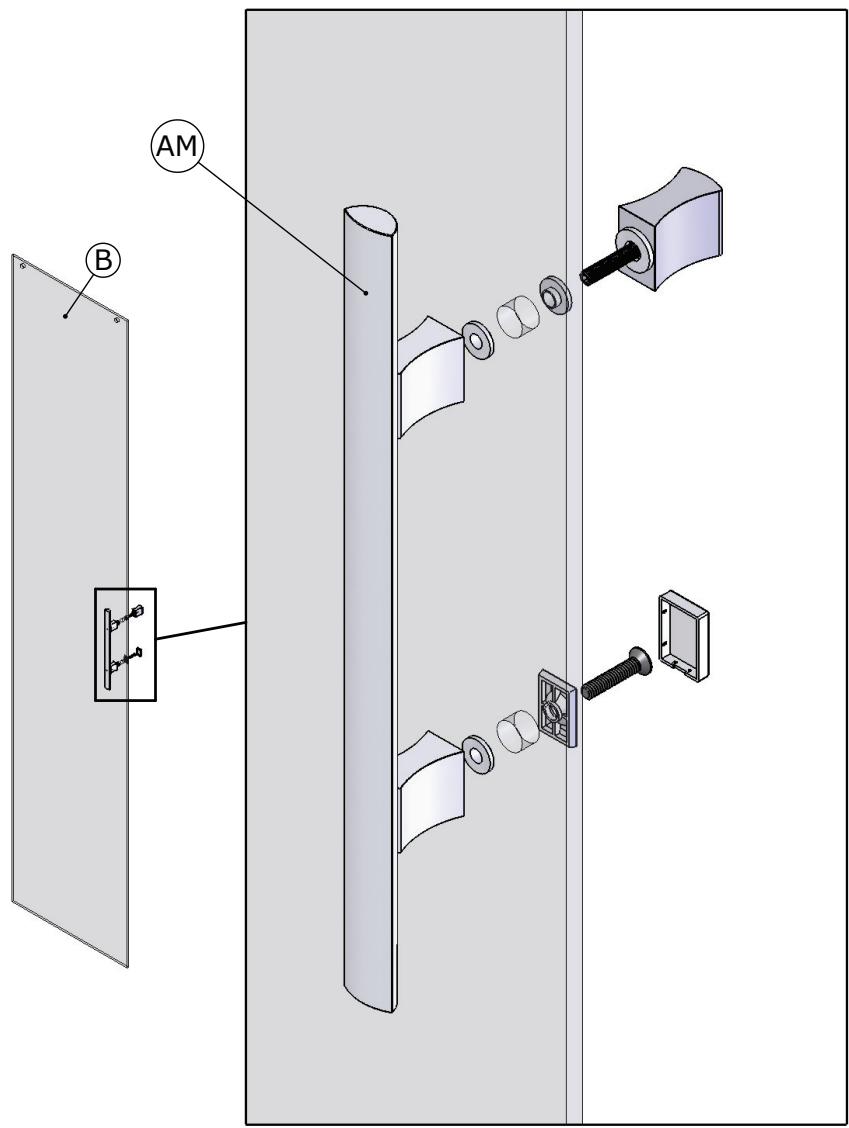

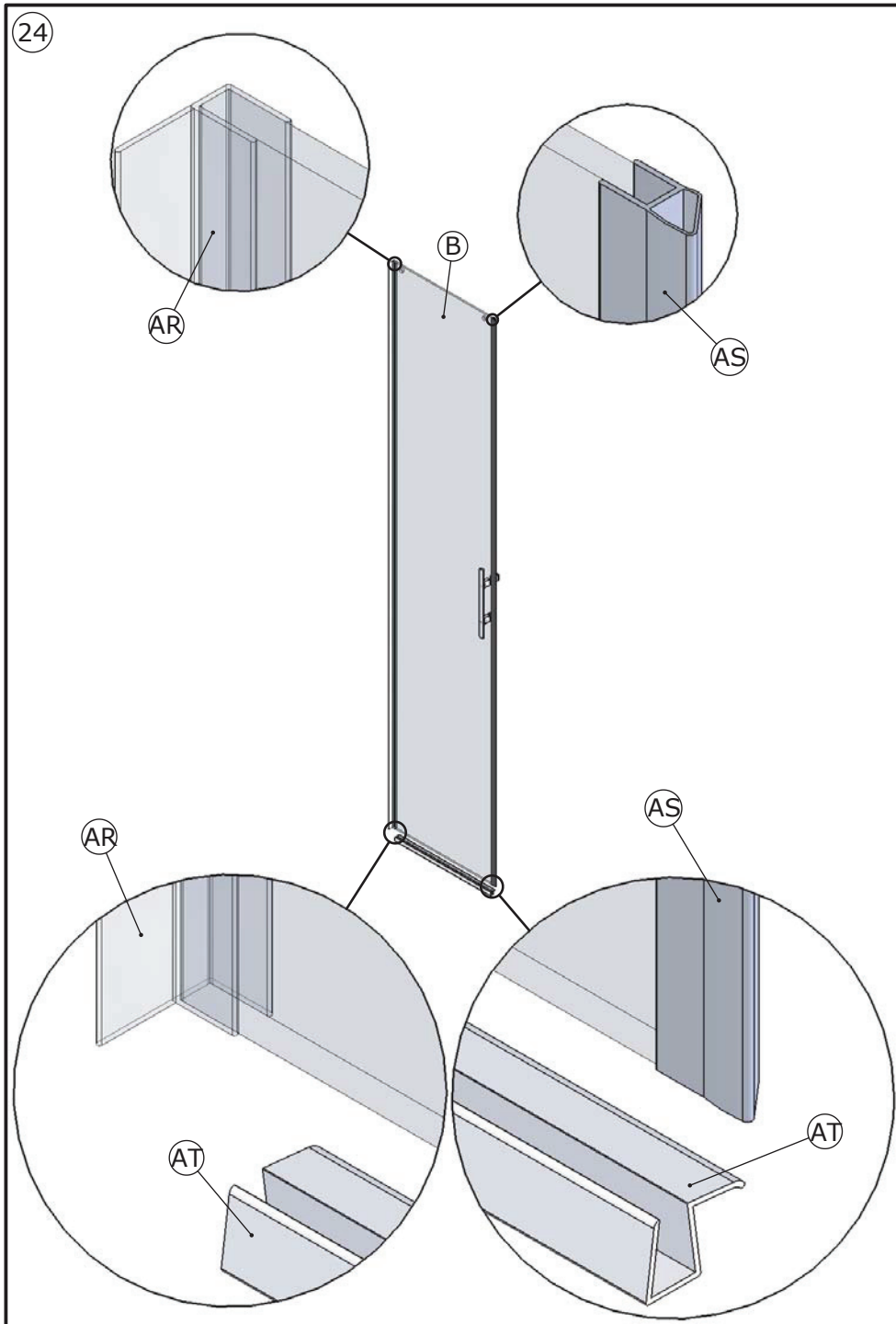

25

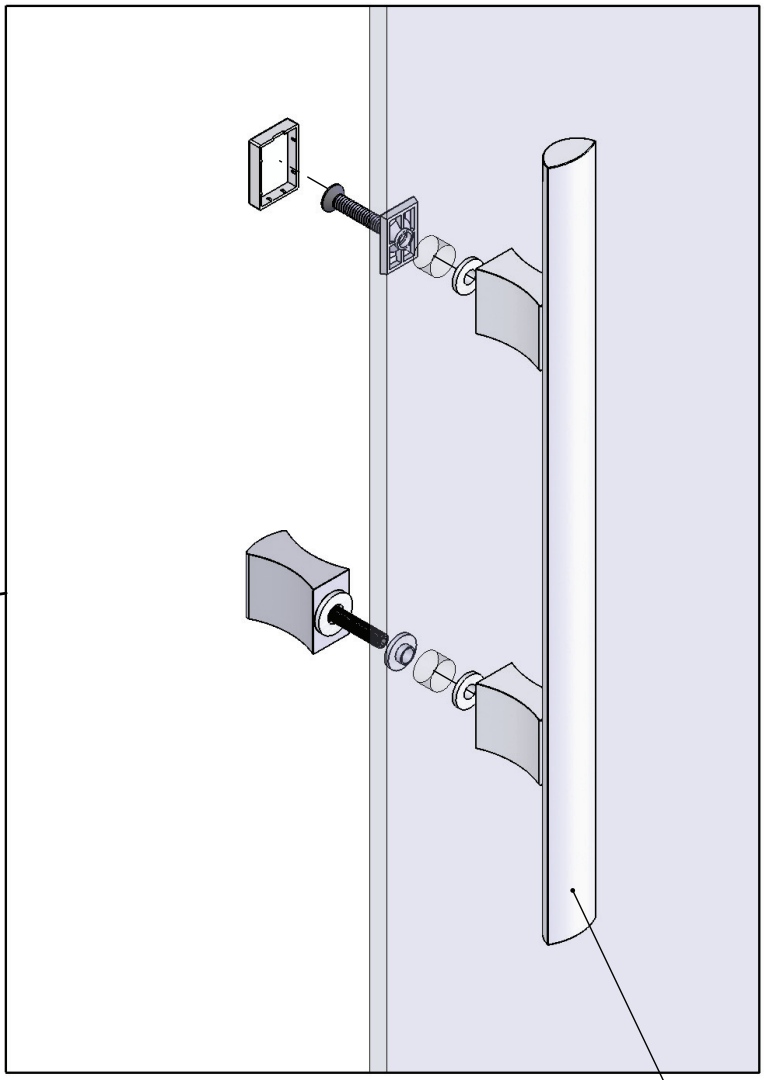
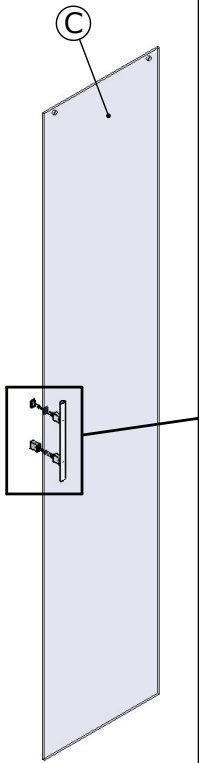

AM

26

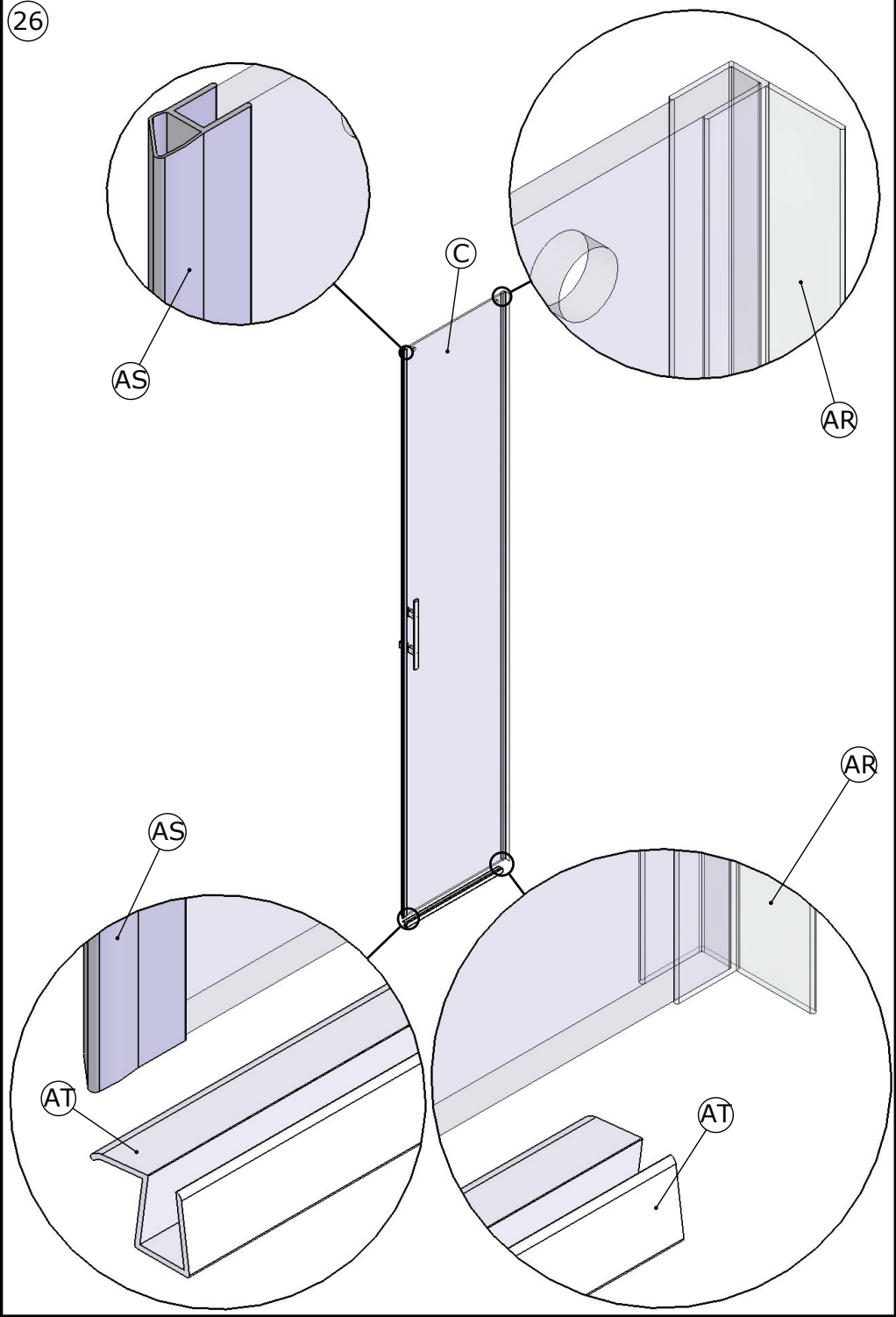

27

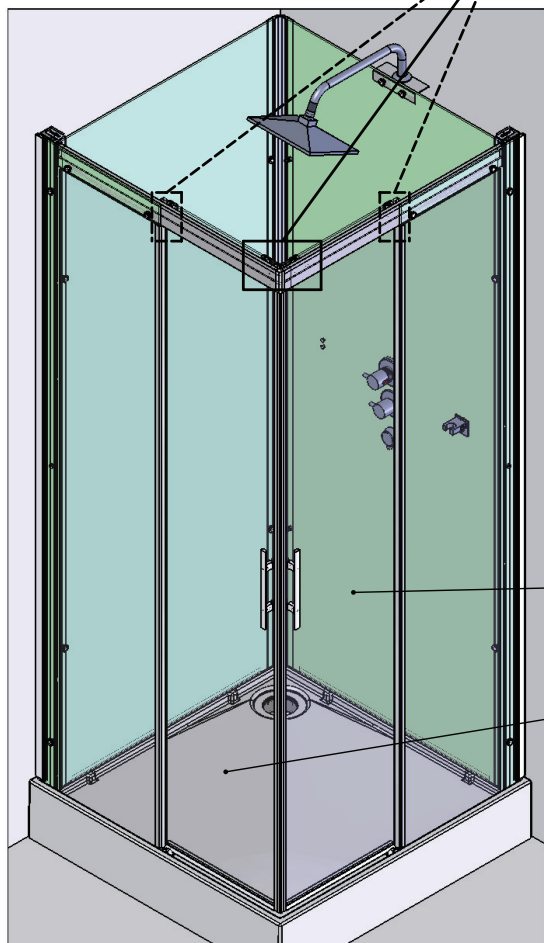
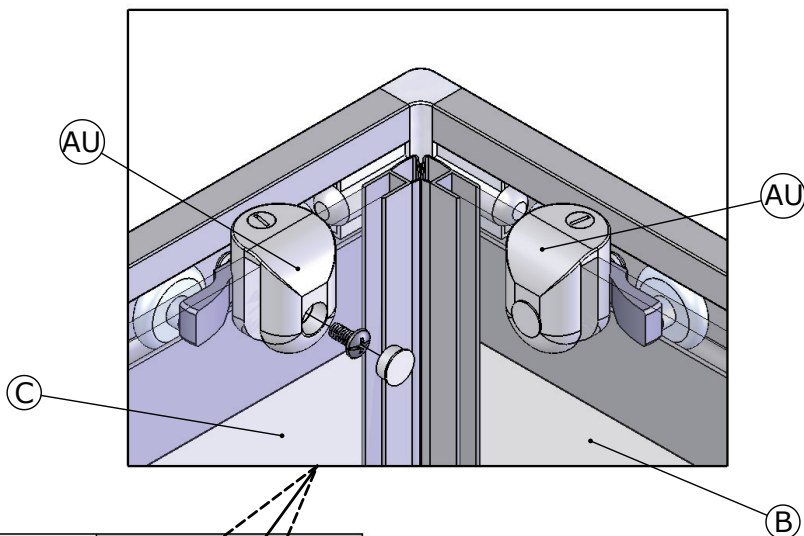

Placer les roulettes dans les rails puis fixer les portes dans les roulettes.
 Place the rollers into the top rail then attach the doors to the rollers. Ensure rollers are at the highest adjustment
 Inserte las ruedas en los railes y fije las puertas a las ruedas.
 Plaats de wieltjes in de rails en zet ze daarna op de deuren vast.

28

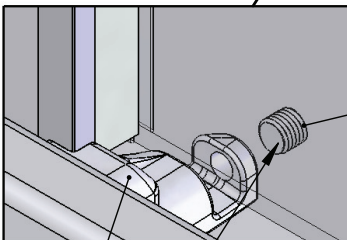
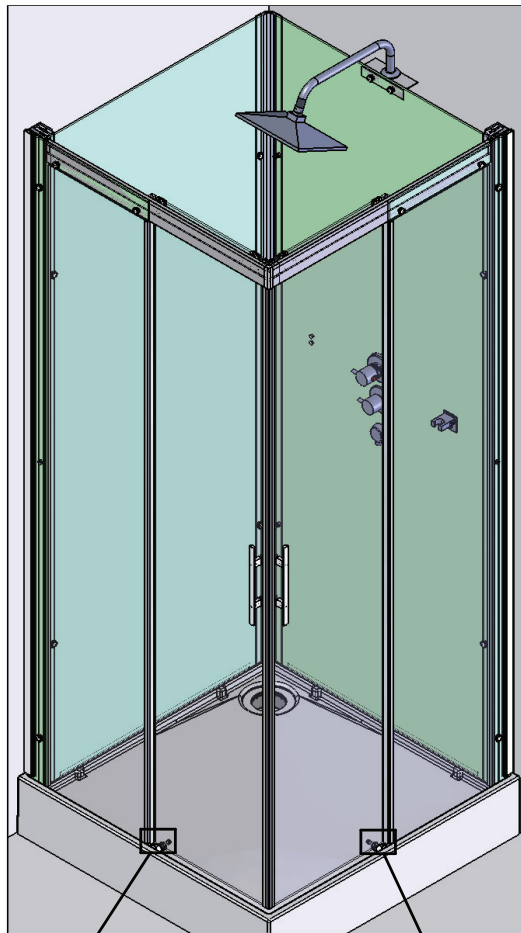

AD

AV

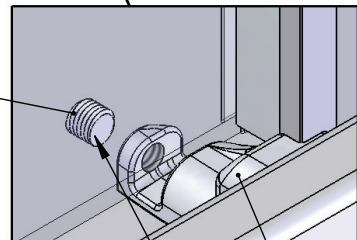

AE

Serrer, puis desserrer d'un demi tour.
 Hand tighten then unscrew half a turn.
 Apriete y desapriete media vuelta.
 Schroef vast en draai daarna een halve slag terug.

29

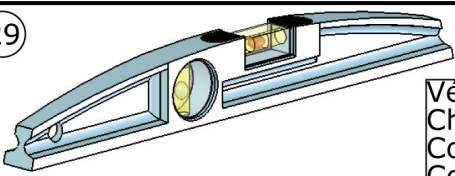

Vérifier l'aplomb de la cabine.
 Check that the cubicle is level.
 Compruebe la seguridad de la cabina.
 Controleer of de cabine waterpas staat.

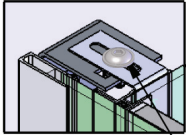

Serrer.
 Tighten.
 Apriete.
 Vastschroeven.

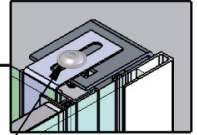
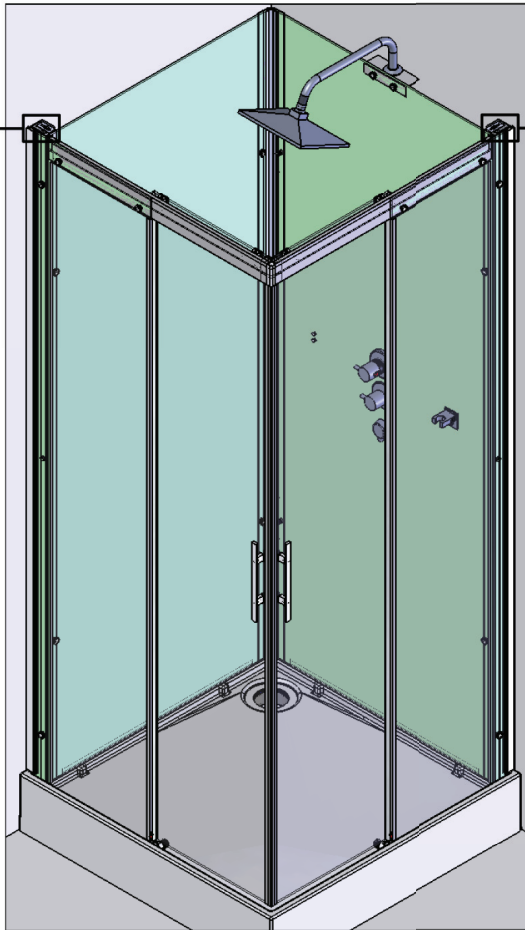

Serrer.
 Tighten.
 Apriete.
 Vastschroeven.

X12

V

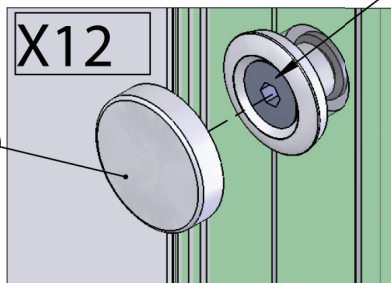

Serrer.
 Tighten.
 Apriete.
 Vastschroeven.

30

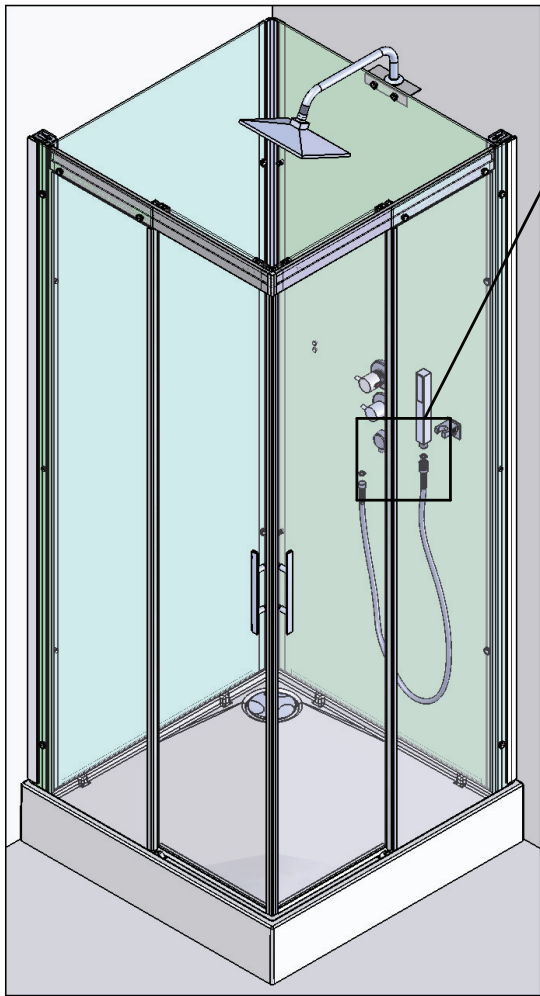
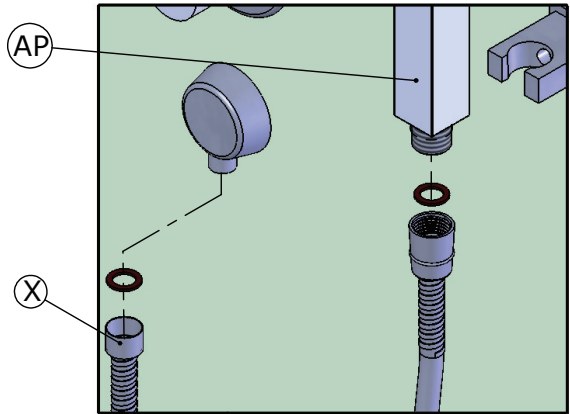

(31)

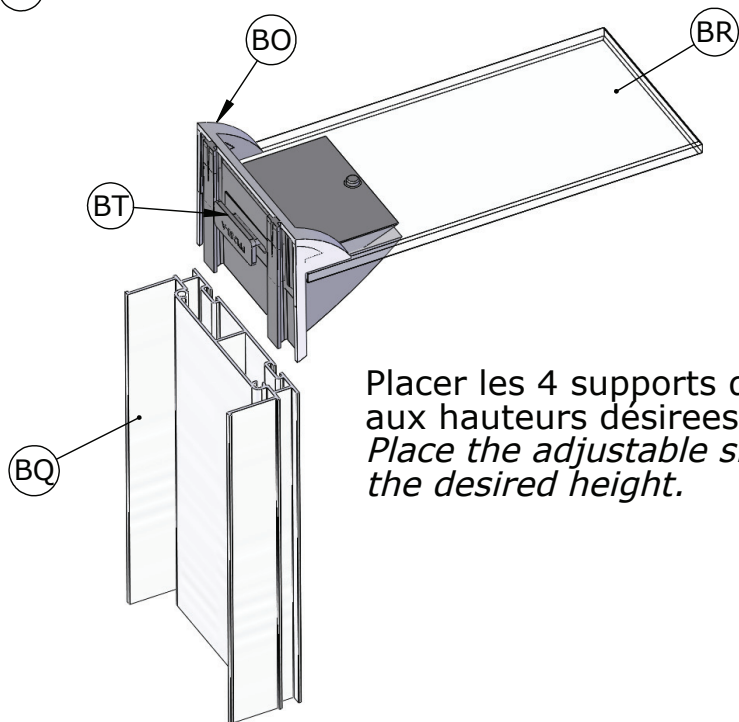
**X4**

Placer les 4 supports d'étagère
aux hauteurs désirées.
*Place the adjustable shelves at
the desired height.*

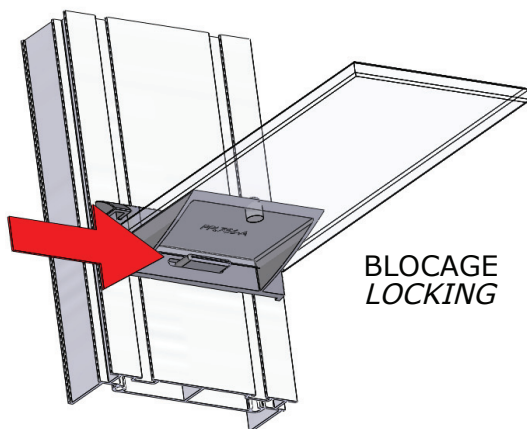

32

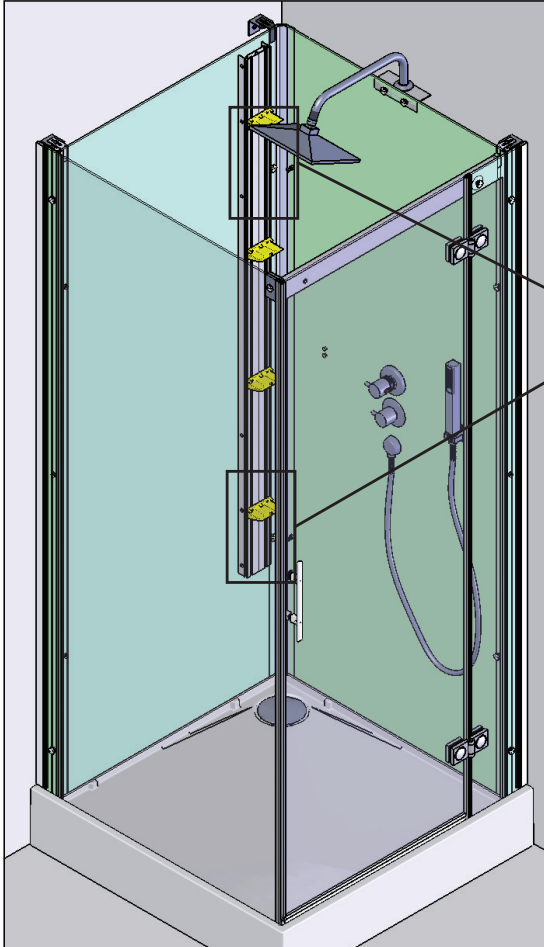

BQ BO

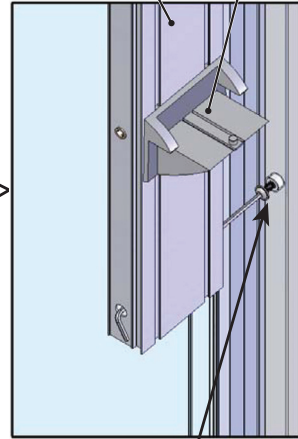

POSER (BQ) SUR LES VIS,
 PUIS SERRER.
 FIX (BQ) OVER THE
 SCREWS THEN TIGHTEN.
 APOYE (BQ) SOBRE LOS
 TORNILLOS Y APRIETE.
 PLAATS (BQ) OP DE
 SCHROEVEN EN SCHROEF
 DAARNA VAST.

33

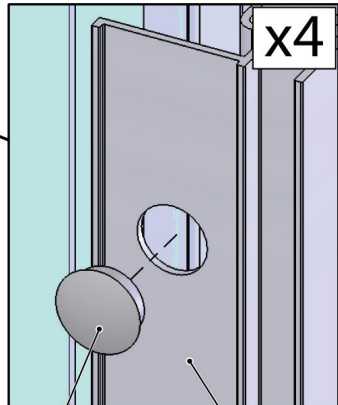
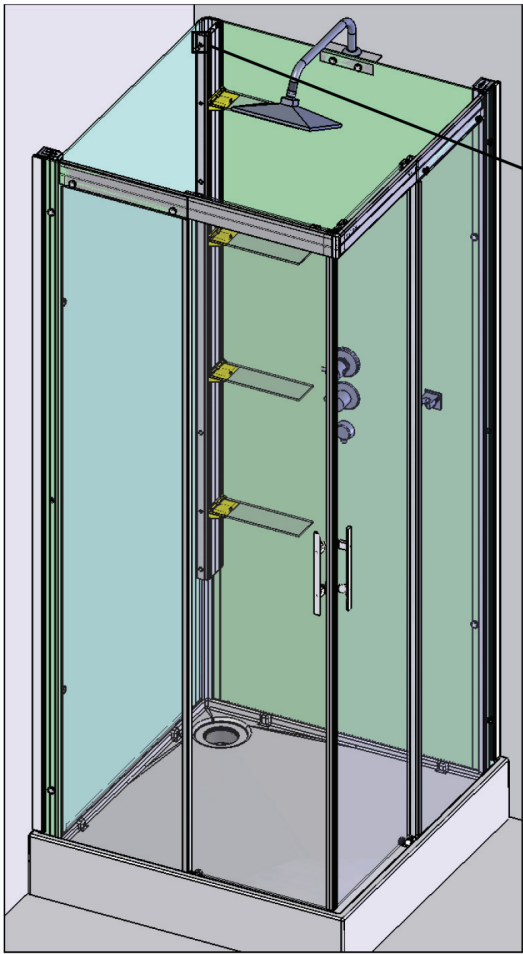

BS

BQ

34

Sérigraphie à l'intérieur.
Screen printing on the
inside.
Impresión en el interior.
Bedrukking aan de
binnenzijde.

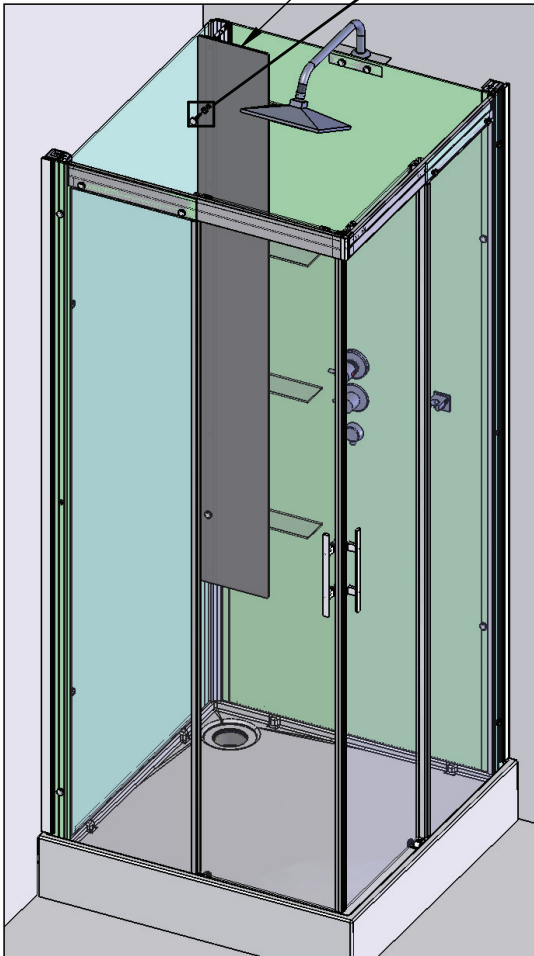
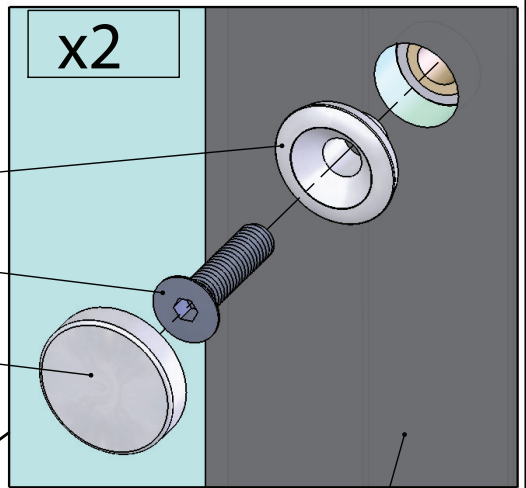

35

Réglage des portes.
Adjust the doors.
Ajuste de las puertas.
Deurregeling.

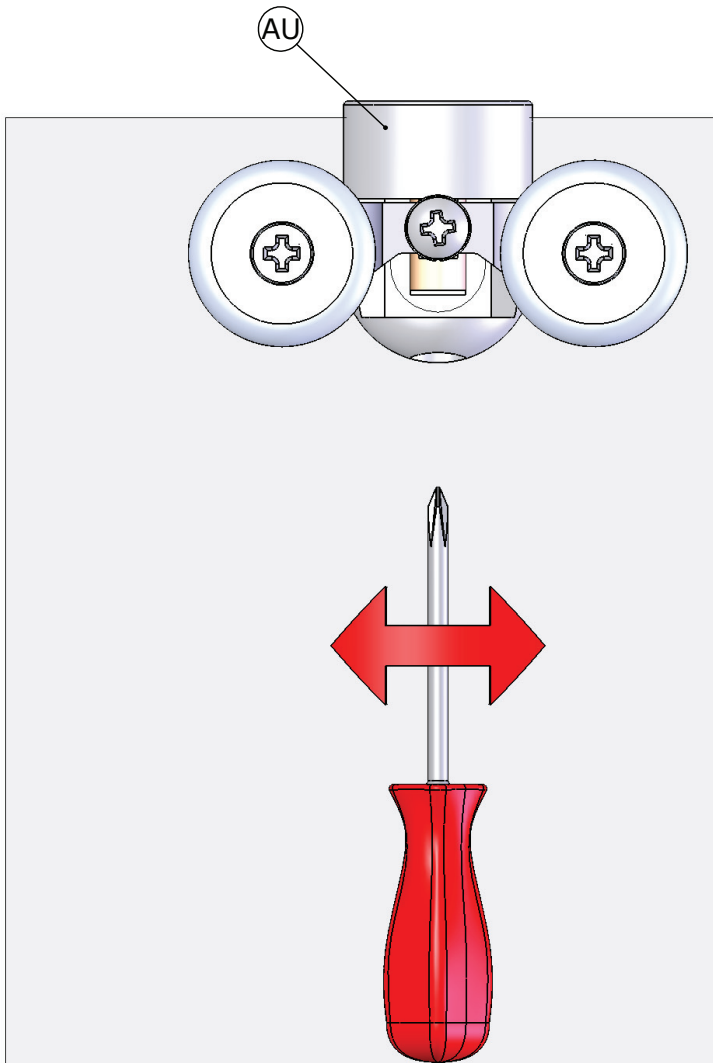



SAV
SERVICE HELPLINES
ASSISTENZA POST-VENDITA
SERVICIO POSTVENTA

FRANCE

02 40 21 29 45

SCHWEIZ

(01) 748 17 44

UK

020 8842 0033

ESPANA

93 544 60 76

IRELAND

04697 33102

NEDERLAND

+31 475 487 100

DEUTSCHLAND

+49 (0) 6074 / 30928 0

BELGIE

+31 475 487 100

ITALIA

(0382) 6181

BELGIQUE

+31 475 487 100

OSTEREICH

+43 1 710 60 70

РОССИЯ

963 19 40, 773 67 22