

# Kinedo

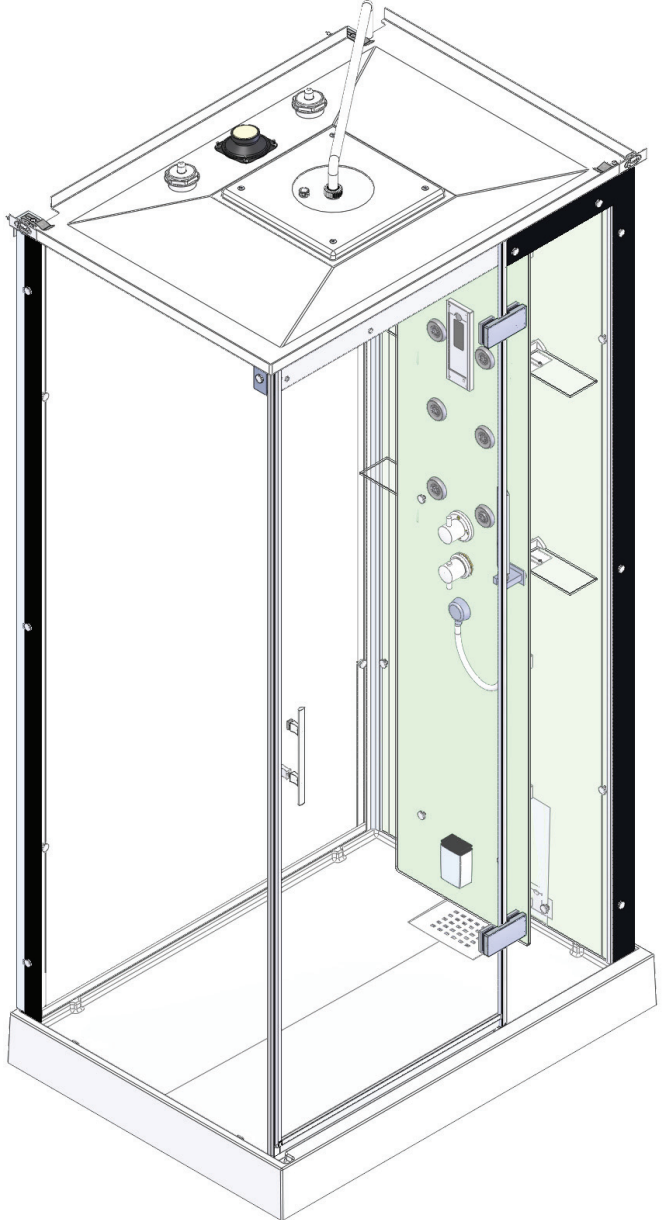

Notre service technique est  
à votre écoute aux numéros  
qui sont au dos de cette  
notice d'installation

## CONSIGNES DE SECURITE ELECTRIQUES

Pour bien installer votre cabine de douche chez vous, vous devez respecter quelques règles :

- l'installation électrique doit être réalisée par un électricien qualifié. Cette installation doit être conforme à la norme NF C 15-100 en vigueur ;
- prévoyez une alimentation électrique indépendante monophasée avec terre 230 Volts-50 Hertz, protégée par un fusible approprié de 16 A (cf. Norme NF en vigueur). Prévoyez aussi un interrupteur différentiel ou un disjoncteur différentiel à courant différentiel résiduel (DDR) ayant un courant de déclenchement n'excédant pas 30 mA et exclusivement destiné à la cabine de douche, et de toute façon conforme aux exigences de la norme en vigueur à la date d'installation. Cette protection est à fournir par vos soins et doit être installée dans le volume 3 des volumes de protection, ou dans une autre pièce. Raccordez par l'intermédiaire du boîtier de connexion, les câbles d'alimentation de l'ensemble (type 3x2,5 mm<sup>2</sup> HO7 RNF fils de cuivre) non fournis ;
- les appareils de classe 1 doivent être raccordés de façon permanente aux installations électriques fixes. Les parties d'appareils comportant des composants électriques, à l'exception des dispositifs de commande à distance, doivent être placés ou fixés de façon telle qu'elles ne puissent pas tomber dans le receveur de douche ;
- prévoyez une protection IP55 pour le boîtier de raccordement de l'alimentation électrique ;
- il est nécessaire de relier les organes métalliques de votre produit au circuit équipotentiel de votre installation ;
- si la tuyauterie d'écoulement du vidage est en cuivre, raccordez celle-ci au conducteur de liaison équipotentielle de la salle de bain par l'intermédiaire d'un collier

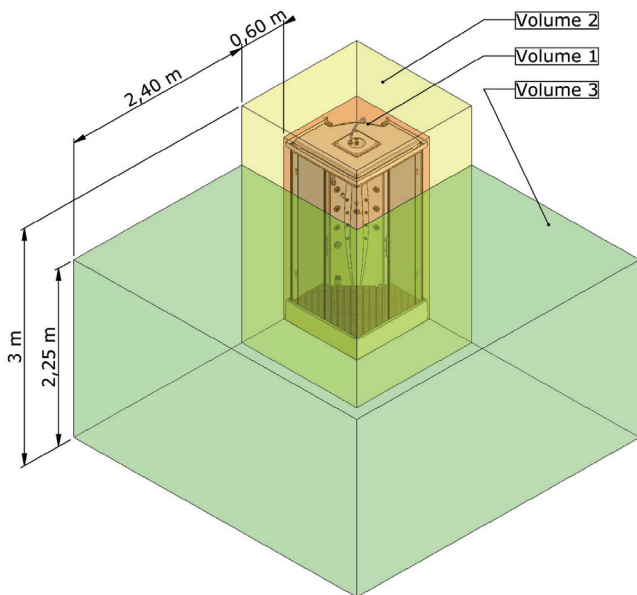

## **SAFETY RECOMMENDATIONS:**

- To install your recycling shower cubicle correctly in your home, you must follow certain rules :
- the electrical installation must be carried out by a qualified electrician. This installation must comply with standard IEC 64-B in force on the date of installation or the national installation standard in force\* ;
- provide an independent single-phase earthed 230 V / 50 Hz power supply protected by an appropriate 16 A fuse (see existing NF standard)Provide also a differential switch or a differential circuit-breaker with residual differential current (DDR) which has a breaking current not exceeding 30 mA, and in any event complying with the requirements of the standard in force on the date of installation. This protection is to be provided by you and must be installed in volume 3 of the protective volumes. Use the connection box to connect the power supply cables of the assembly (type 3x1,5 mm<sup>2</sup> HO7 RNF copper wires) not supplied\* ;
- the class I equipment must be connected permanently to the fixed electrical installations. Equipment parts comprising electrical components, with the exception of remote control devices, must be positioned or secured in such a way that they cannot fall into the shower basin\* ;
- if the drainage outflow pipe is made of copper, connect it to the bathroom's equipotential bonding conductor via a ring.

## **ASSEMBLY RECOMMENDATIONS:**

- The total height of your cubicle is 210 cm; it is therefore imperative to have a ceiling height of at least 250 cm in order to have enough room to handle tools during attachment to the wall ;
  - the hot water inlet and cold water inlet connection is made by means of a 15/21 (1/2") 80 cm hose ;
  - provide an electrical cable approximately 80 cm long (cable with three conductors with nominal section greater than 1.5 mm<sup>2</sup>)\* ;
  - the external outlet of your shower basin must be a flexible pipe with a diameter of 40 mm, to prevent the transmission of vibrations ;
  - all preparation of the floor and walls (paint, ceramics, tiling, etc.) must be completed before starting to assemble your cubicle.
- ATTENTION: If your water is hard, we strongly recommend the installation of a softener water to preserve the hammam function.**

\*Cubicle with hammam

## **VEILIGHEIDSAADVIJES:**

- Om uw waterbesparende douchecabine thuis goed te kunnen installeren moet u enkele regels naleven:
- de elektrische installatie moet door een erkend elektricien worden uitgevoerd. Deze installatie moet conform zijn met de CEI 64-8 norm geldig op installatiedatum, of met de geldende nationale installatienorm\* ;
  - voorzie een onafhankelijke, monofasige elektrische voeding van 230 Volt 50 Hertz met aarding, beschermd door een geschikte zekering van 16 A (cfr. de geldende NF-norm). Voorzie ook een differentiaalverschakelaar of een differentiaalonderbreker op differentiale reststroom met een schakelvermogen onder 30 mA, conform de geldende norm op de installatiedatum. U moet deze zekering zelf plaatsen buiten de natte zone. Sluit de voedingskabels voor het geheel (type 3 x 1,5 mm<sup>2</sup> HO7 RNF koperdraad) aan via een verbindingsdoos (niet meegeleverd)\* ;
  - de Klasse I-toestellen moeten permanent worden aangesloten op een vaste elektrische installatie. De toestel delen met elektrische onderdelen, uitgezonderd de afstandsbediening, moeten zo worden geïnstalleerd of verankerd dat ze niet in de douchebak kunnen vallen\* ;
  - sluit een koperen afvoerleiding (indien gebruikt) met een klem aan op de equipotentiaalverbinding van de badkamer.

## **MONTAGE-INSTRUCTIES:**

- De totale hoogte van uw cabine bedraagt 210 cm. De minimale hoogte onder plafond is bijgevolg 250 cm, zodat er voldoende ruimte is om het gereedschap te hanteren bij de plaatsing tegen de muur ;
  - de warm- en koudwatertoevoer worden met een slang aangesloten 15/21 (1/2") van 80 cm ;
  - voorzie een elektriciteitsnoer van ongeveer 80 cm (kabel met drie geleiders, nominale doorsnede groter dan 1,5 mm<sup>2</sup>) ;
  - de externe afvoer van de doucheleiding bestaat uit een soepele leiding van Ø 40 mm, zodat trillingen bij overdracht worden vermeden ;
  - voor u met de montage van de cabine begint moet u de vloer en de muren voorbereiden (verf, aardewerk, tegels, ...).
- AANDACHT: Indien het water in uw badkamer kalkrijk is, bevelen wij ten sterkste een waterontharder aan om de stoomfunctie in goede conditie te behouden.**

\* cabine hammam

## CONSEJOS DE SEGURIDAD:

Para la correcta instalación de su cabina de ducha de hidromasaje/baño-vapor en casa debe respetar algunas normas :

- la instalación eléctrica deberá realizarla un electricista cualificado. La instalación deberá ser conforme a la norma CEI 64-8 vigente en la fecha de instalación o a la norma de instalación nacional vigente\* ;
- deberá preverse una instalación eléctrica independiente monofásica con toma de tierra de 230 voltios - 50 hertzos protegida por un fusible apropiado de 16A. Prevea también un interruptor diferencial o un disyuntor diferencial de corriente diferencial residual (DDR) con una corriente de accionamiento que no supere los 30mA, y que en cualquier caso respete las exigencias de la norma vigente en la fecha de la instalación. Esa protección deberá ser aportada por su parte y deberá instalarse fuera de los volúmenes de protección. Conecte mediante la caja de conexión el conjunto de cables de alimentación (tipo 3x2,5 mm<sup>2</sup> HO7 RNF hilos de cobre) no incluido\* ;
- los aparatos de clase I deberán conectarse de forma permanente a las instalaciones eléctricas fijas. Las partes de aparatos que tengan componentes eléctricos, exceptuando los dispositivos de accionamiento a distancia, deben colocarse o fijarse de tal manera que no puedan caer en el plato de la ducha\* ;
- si la tubería de desagüe es de cobre, conéctela al conductor de conexión equipotencial del cuarto de baño mediante un collar.

## CONSEJOS DE MONTAJE:

- La altura total de su cabina es de 210 cm, por lo tanto, es imperativo contar con una altura bajo techo de 250 cm para disponer de suficiente espacio a la hora de utilizar las herramientas durante la fijación a la pared ;
- el desague de entrada de agua caliente y la de entrada de agua fría deberán realizarse con un flexible 15/21 (1/2") de 80 cm ;
- prevea un cable eléctrico de alrededor de 80 cm (cable de tres conductores, sección nominal superior a 2,5 mm<sup>2</sup>)\* ;
- el desague exterior de su plato deberá consistir en una tubería flexible de Ø40 mm para evitar la transmisión de vibraciones ;
- antes de empezar el montaje de su cabina deberá haber terminado la preparación del suelo y de las paredes (pintura, revestimiento, alcatado...)

**ATENCIÓN: Si el agua de su zona tiene mucha cal, le recomendamos que instale un descalcificador para preservar la función baño vapor**

\*Cabina baño-vapor

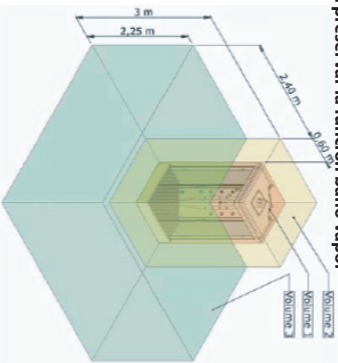

MONTAGE A DROITE  
RIGHT HAND  
MONTAJE A LA DERECHA  
MONTAGE RECHTS



MONTAGE A GAUCHE  
LEFT HAND  
MONTAJE A LA IZQUIERDA  
MONTAGE LINKS

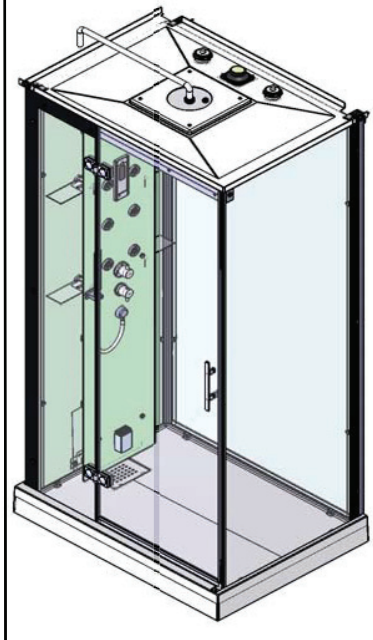

Vous avez la possibilité de réaliser un montage à droite ou un montage à gauche. Notre notice d'installation décrit un montage à droite. si vous voulez réaliser un montage à gauche, il vous suffit d'inverser le montage.

This cubicle can be installed either left or right hand. These installation instructions show a right hand installation.

Puede realizar un montaje a la derecha o un montaje a la izquierda. Nuestro folleto de instalación describe un montaje a la derecha. Si desea montar su cabina a la izquierda sólo tendrá que realizar el montaje al contrario.

U kunt de cabine rechts of links monteren. Onze handleiding beschrijft de rechtse montage van de cabine. Keer de montage om als u de cabine links wilt monteren.

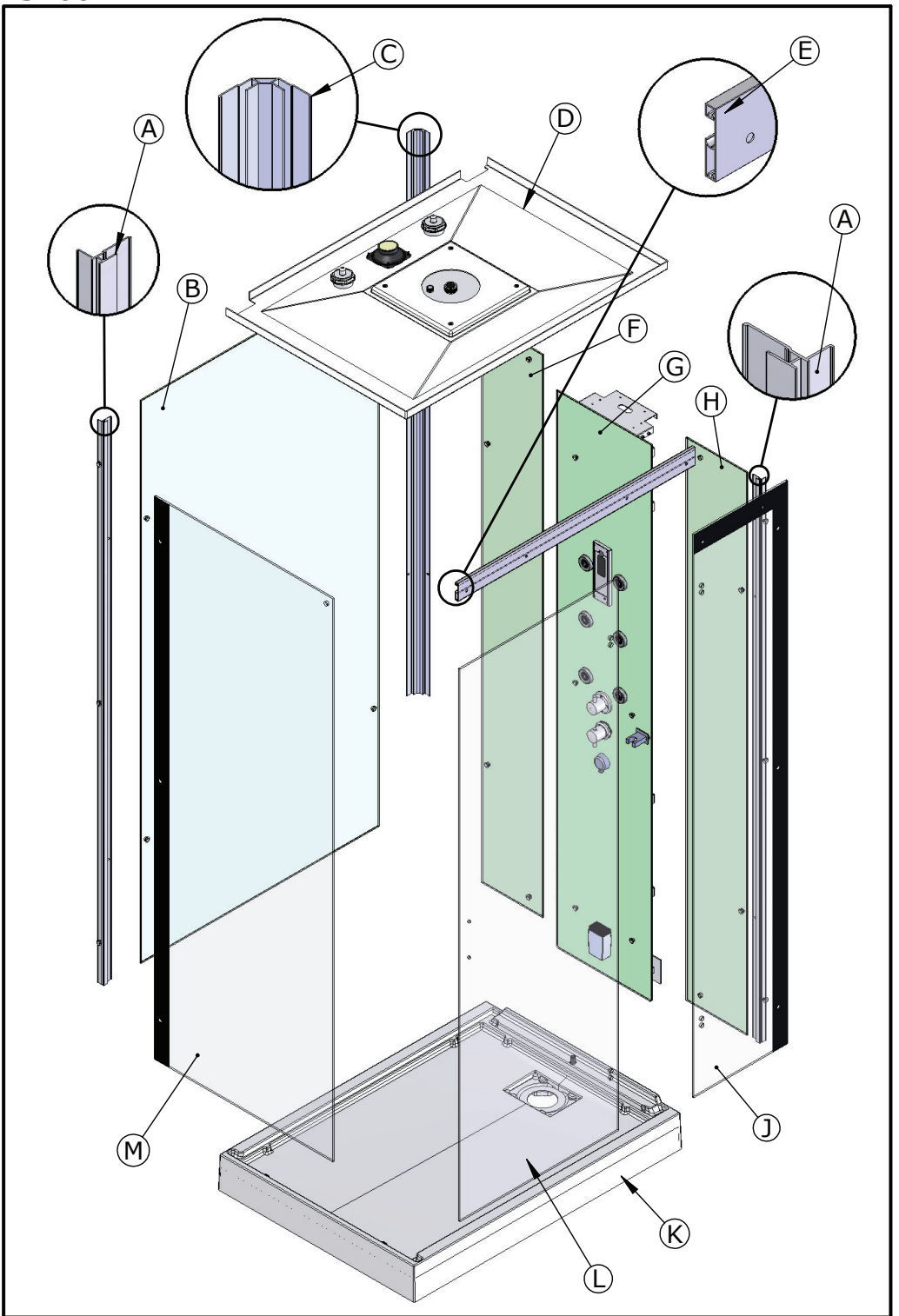



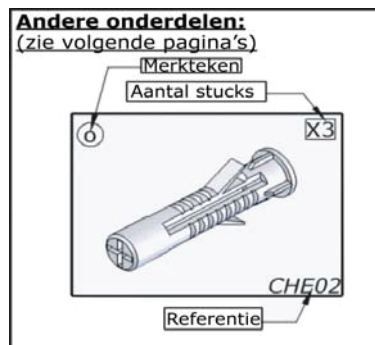
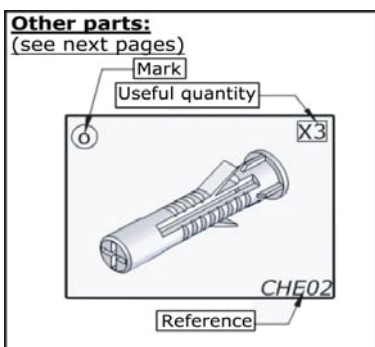
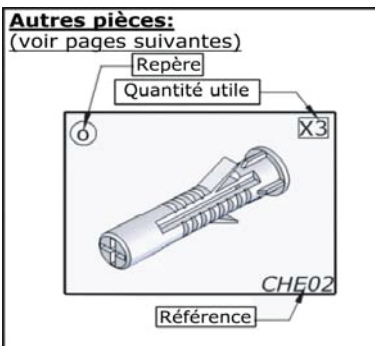

**CODES COLIS (voir repères en page 6)**  
**PACKAGE CODES (see marks on page 6)**  
**CODIGOS BULTOS (ver marcas en pagin  6)**  
**CODERING VERPAKKING (zie omschrijving op pagina 6)**

REP	VERSION	110x80	120x90
A		5934	
B	Acier	C5081E	C6499E
	Chrysolite	C5081E	C6499E
	Perle Noire	C5081E	C6499E
	P�p�te	C5081E	C6499E
	Rubis	C5081E	C6499E
	Saphir	C5081E	C6499E
	Flamenco Rubis	C5405E	
	Tango	C5408E	C6577E
C		5933	
D		C6437	C6502
E		5902	
F+H	Acier	C6434E	C6433E
	Chrysolite	C6550E	C6503E
	Perle Noire	C6552E	C6505E
	P�p�te	C6553E	C6506E
	Rubis	C6551E	C6504E
	Saphir	C6554E	C6507E
	Flamenco Rubis	C6551E	
	Tango	C6552E	C6505E
G		CP477	
J+L	Acier	C6377E	C6538E
	Chrysolite	C6363E	C6539E
	Perle Noire	C6359E	C6541E
	P�p�te	C6379E	C6542E
	Rubis	C6381E	C6540E
	Saphir	C6361E	C6543E
	Flamenco Rubis	C6381E	
	Tango	C6359E	C6541E
K	H12	REC221	REC218
	H18	REC224	REC225
M	Acier	C6444E	C6526E
	Chrysolite	C6445E	C6527E
	Perle Noire	C6446E	C6529E
	P�p�te	C6448E	C6530E
	Rubis	C6447E	C6528E
	Saphir	C6449E	C6531E
	Flamenco Rubis	C6447E	
	Tango	C6446E	C6529E

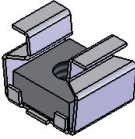
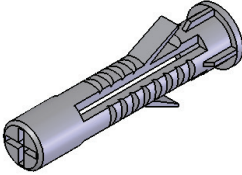
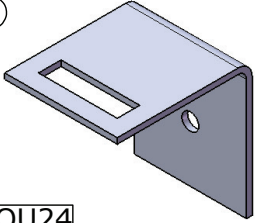
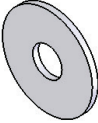
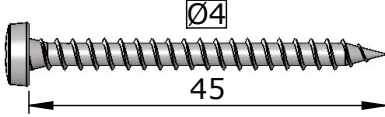

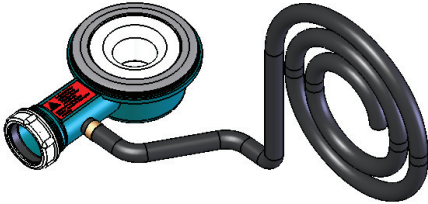
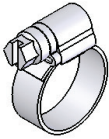
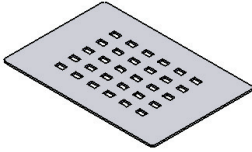

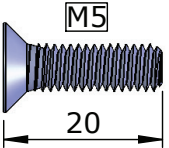
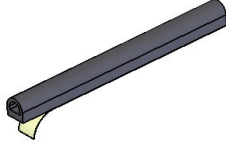
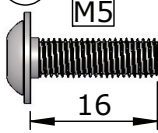
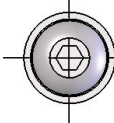
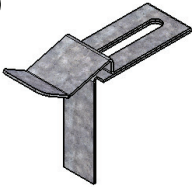
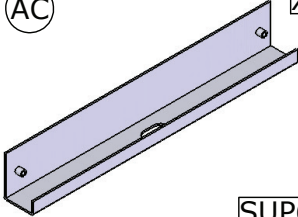
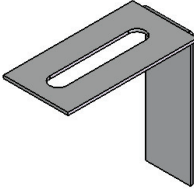





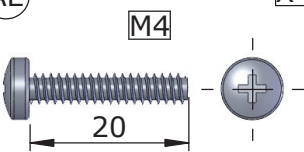
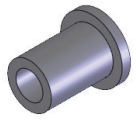
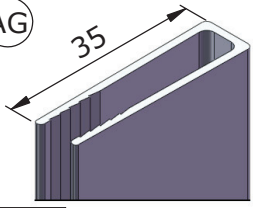
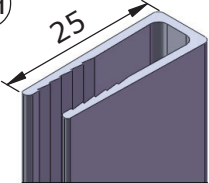
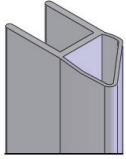
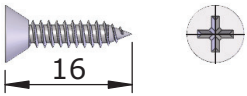
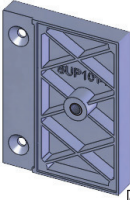
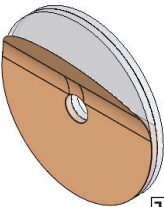

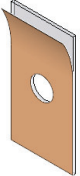

<p>(N) X3</p>  <p>1=1 ECR46</p>	<p>(O) X3</p>  <p>1=1 CHE02 EQU24</p>	<p>(P) X3</p> 
<p>(Q) X5</p>  <p>1=1 RON51</p>	<p>(R) X3</p>  <p>Ø4 45</p>  <p>1=1 VIS210</p>	
<p>(T) X1</p>  <p>BOND18</p>		
<p>(V) X2</p>  <p>CLR09</p>	<p>(W) X1</p>  <p>TOL11</p>	<p>(X) X21</p>  <p>1=1 ENT19</p>
<p>(Y) X18</p>  <p>M5 20</p> <p>1=1 VIS10</p>	<p>(Z) X2</p>  <p>JOI86</p>	<p>(AA) X3</p>  <p>M5 16</p>  <p>1=1 VIS195</p>
<p>(AB) X2</p>  <p>EQU56</p>	<p>(AC) X2</p>  <p>SUP63</p>	<p>(AD) X1</p>  <p>EQU50</p>

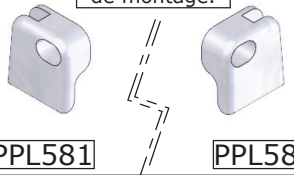
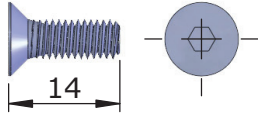
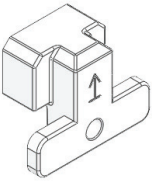
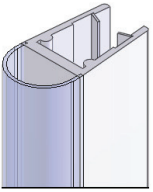
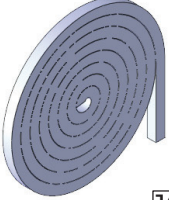
Les quantités données sont les quantités utiles au montage. Les sachets fournis contiennent des pièces supplémentaires. The quantities given are what are required for the installation. There may be some surplus parts in the package provided.

# DES760K

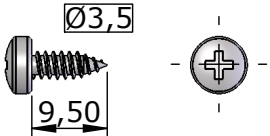
<p>(AE) X4</p>  <p>M4 20 1=1</p> <p>VIS09</p>	<p>(AF) X3</p>  <p>1=1</p> <p>ECR14</p>	<p>(AG) X1</p>  <p>35 1=1</p> <p>PFL42</p>
<p>(AH) X1</p>  <p>25 1=1</p> <p>PFL43</p>	<p>(AI) X1</p>  <p>Lg=2000mm 1=1</p> <p>AI036</p>	<p>(AJ) X1</p>  <p>Ø3,5 16 1=1</p> <p>VIS06</p>
<p>(AK) X1</p>  <p>SUP101</p>	<p>(AL) X2</p>  <p>JOI158</p>	<p>(AM) X4</p>  <p>1=1</p> <p>CAP15</p>
<p>(AN) X1</p>  <p>JOI157</p>	<p>(AO) X2</p>  <p>1=1</p> <p>ECR31</p>	<p>(AP) X21</p>  <p>1=1</p> <p>CAP07</p>
<p>(AQ) X1</p>  <p>TOL17</p>	<p>(AR) X1</p> <p>Utiliser une des deux pièces suivant le sens de montage.</p>  <p>PPL581 PPL582</p>	<p>(BO) X3</p>  <p>M5 14 1=1</p> <p>VIS159</p>
<p>(AS) X1</p>  <p>PPL550</p>	<p>(AV) X1</p>  <p>Lg=1983mm J522</p>	<p>(AW) X2</p>  <p>JOI362</p>

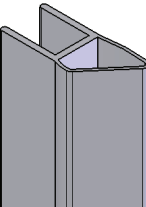
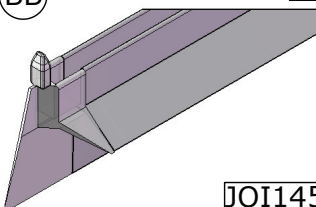
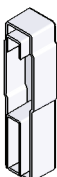
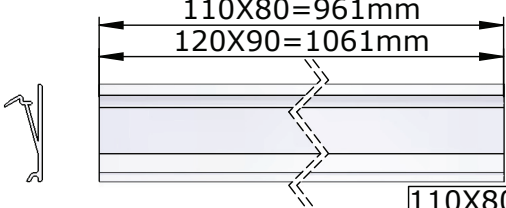
Les quantités données sont les quantités utiles au montage. Les sachets fournis contiennent des pièces supplémentaires. The quantities given are what are required for the installation. There may be some surplus parts in the package provided.

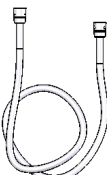
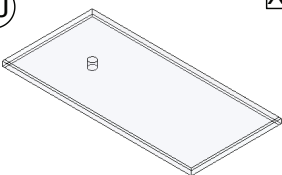
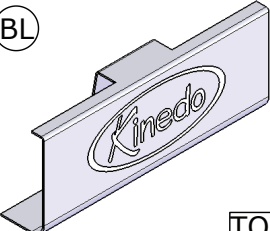
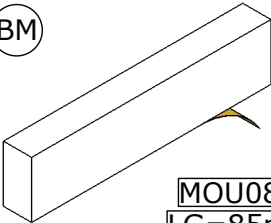
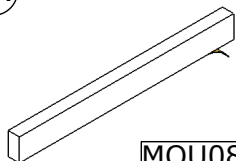
<p>(AX) X5</p>  <p>1=1 VIS01</p>		<p>(AZ) X4</p>  <p>PGN19</p>
<p>(BA) X1</p>  <p>Lg = 1954 mm AI068</p>	<p>(BB) X1</p>  <p>JOI145</p>	
		<p>(BF) X1</p>  <p>PPL583</p>
<p>(BG) X1</p>  <p>110X80=P020 120X90=P025</p>		<p>(BH) X1</p>  <p>KIT76</p>
<p>(BI) X1</p>  <p>FLEX05</p>	<p>(BJ) X4</p>  <p>VER2161</p>	
<p>(BL) X2</p>  <p>TOL19</p>	<p>(BM) X2</p>  <p>MOU08C1 LG=85mm</p>	<p>(BN) X1</p>  <p>MOU08C2 LG=190mm</p>

Les quantités données sont les quantités utiles au montage. Les sachets fournis contiennent des pièces supplémentaires. The quantities given are what are required for the installation. There may be some surplus parts in the package provided.

# DES760K

Les quantités données sont les quantités utiles au montage.  
Les sachets fournis contiennent des pièces supplémentaires.

The quantities given are what are required for the installation.  
There may be some surplus parts in the package provided.

Las cantidades indicadas son las cantidades necesarias para el montaje.  
Las bolsitas incluidas contienen piezas suplementarias.

De aangegeven hoeveelheid toont het aantal onderdelen dat voor montage nodig is.  
De meegeleverde zakjes kunnen meer onderdelen bevatten.

Matériel nécessaire :  
Tools required :  
Material necesario :  
Nodige gereedschap :

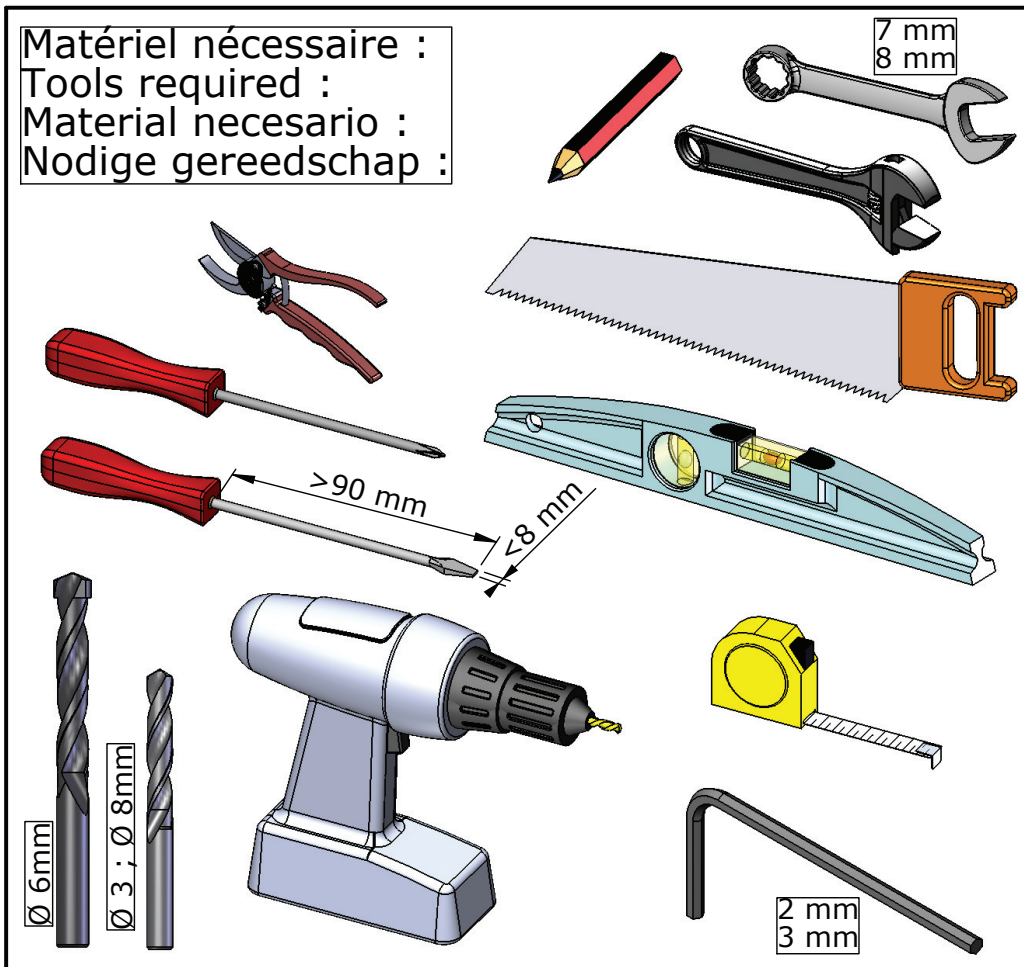

01

Ø6 mm

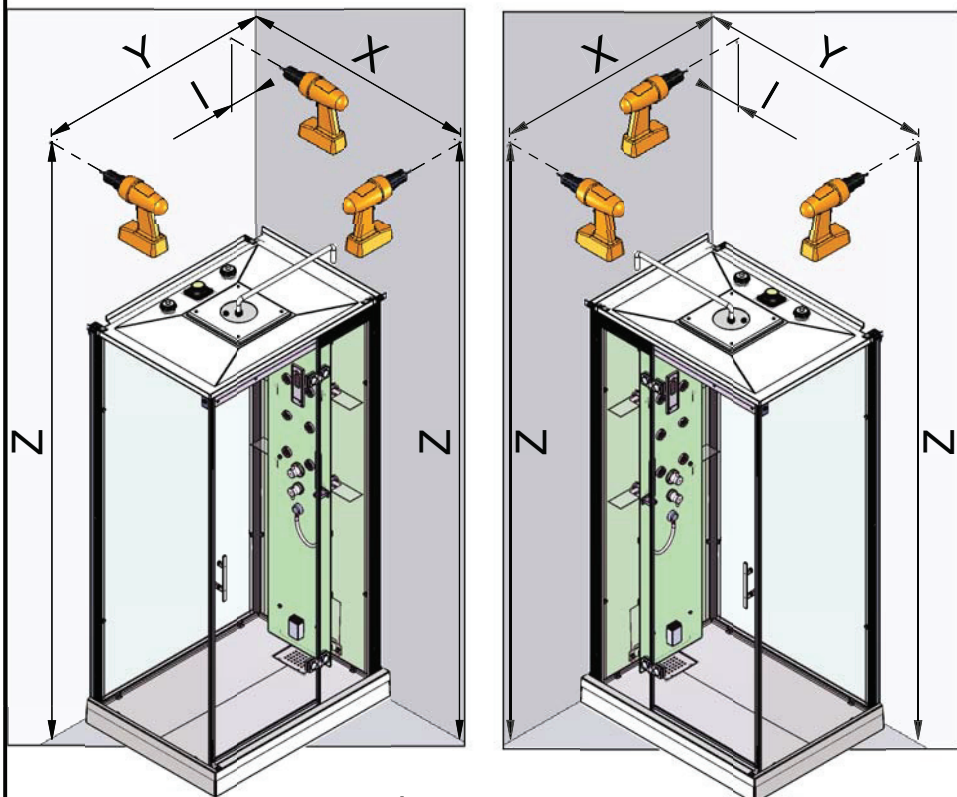

Cabine 110x80

X	74 cm	
Y	103 cm	
Z	 12 cm 207,5 cm	 17.5 cm 212,5 cm
I	10 cm	

01

Ø6 mm

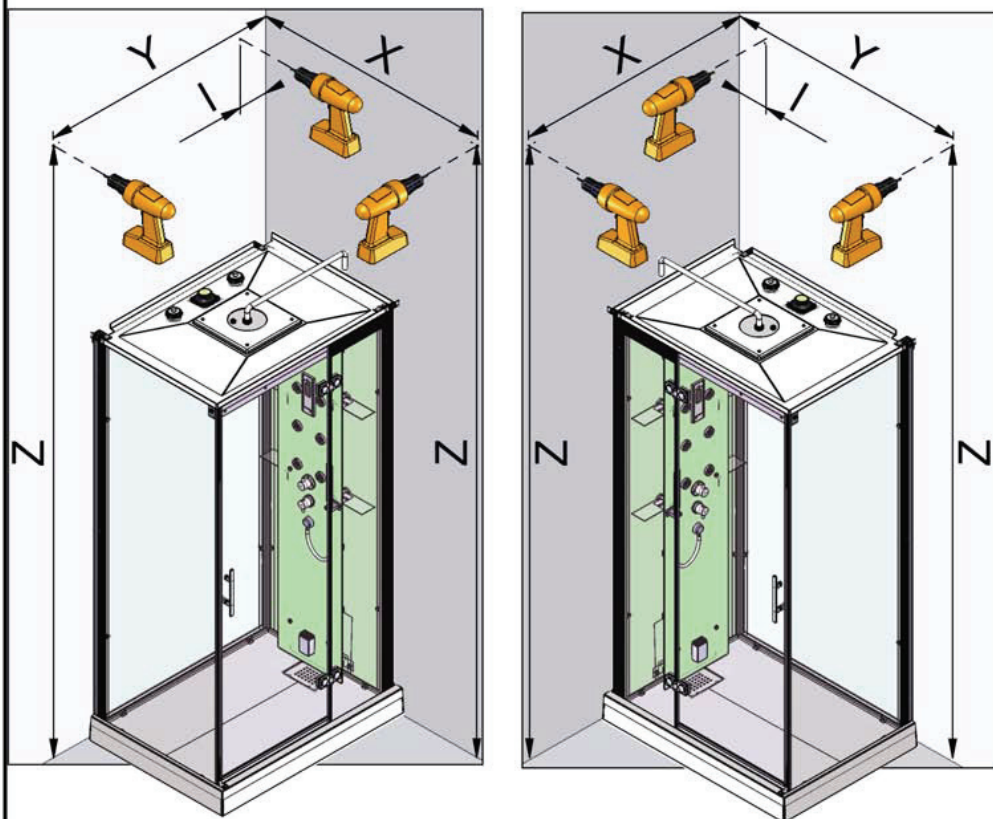

### Cabine 120x90

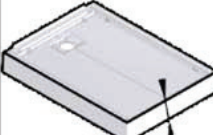
X	<b>84 cm</b>	
Y	<b>113 cm</b>	
Z	 <b>13 cm</b> 207,5 cm	 <b>18 cm</b> 212,5 cm
l	10 cm	

02

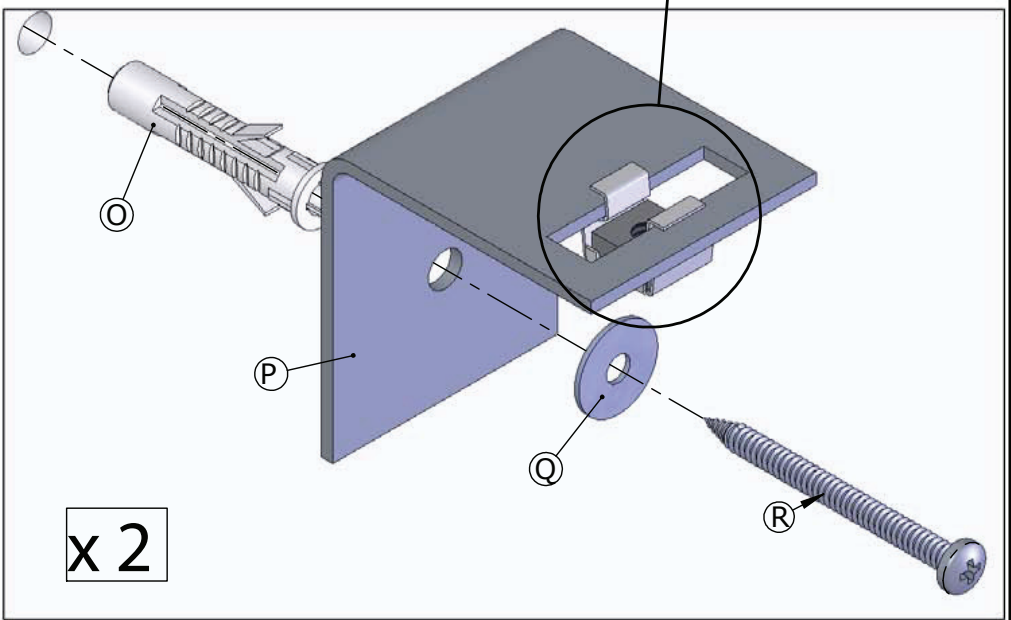
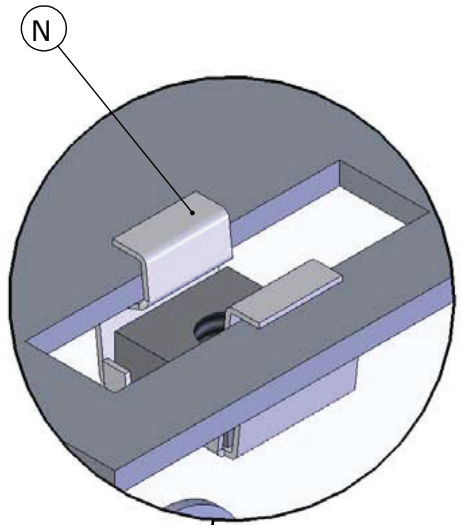

x 2

03

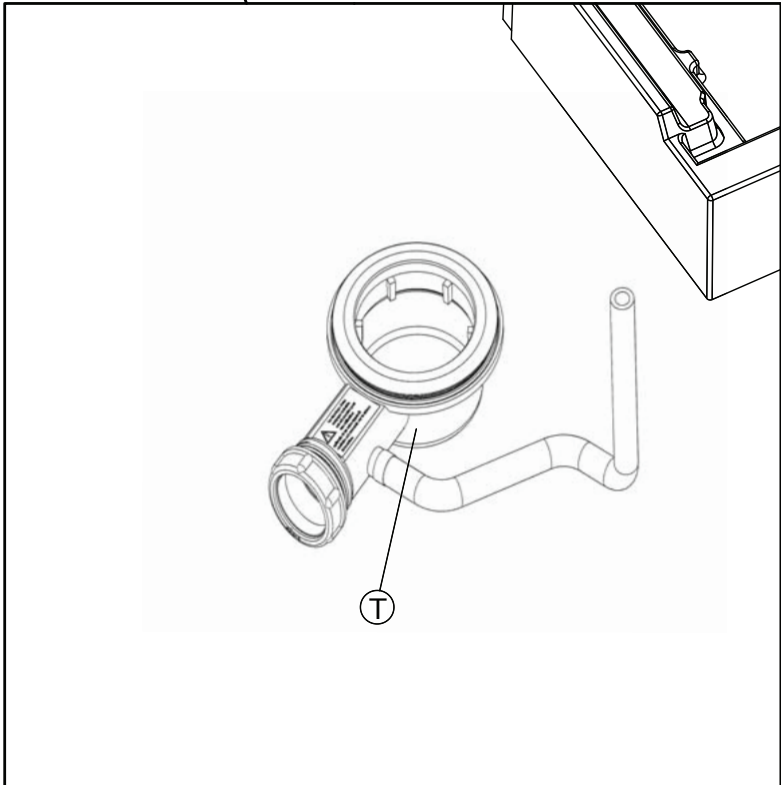
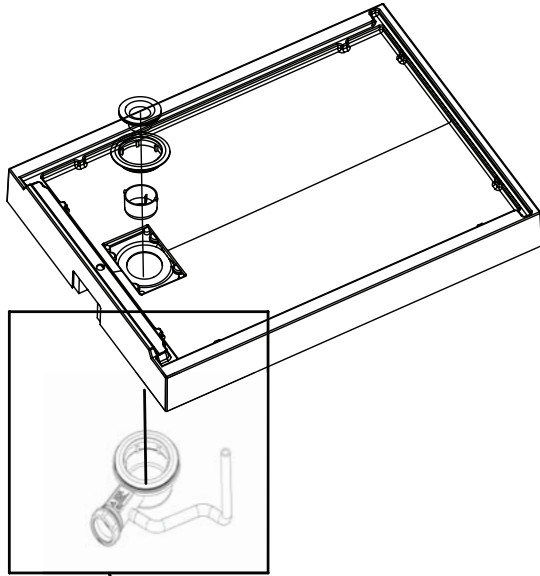



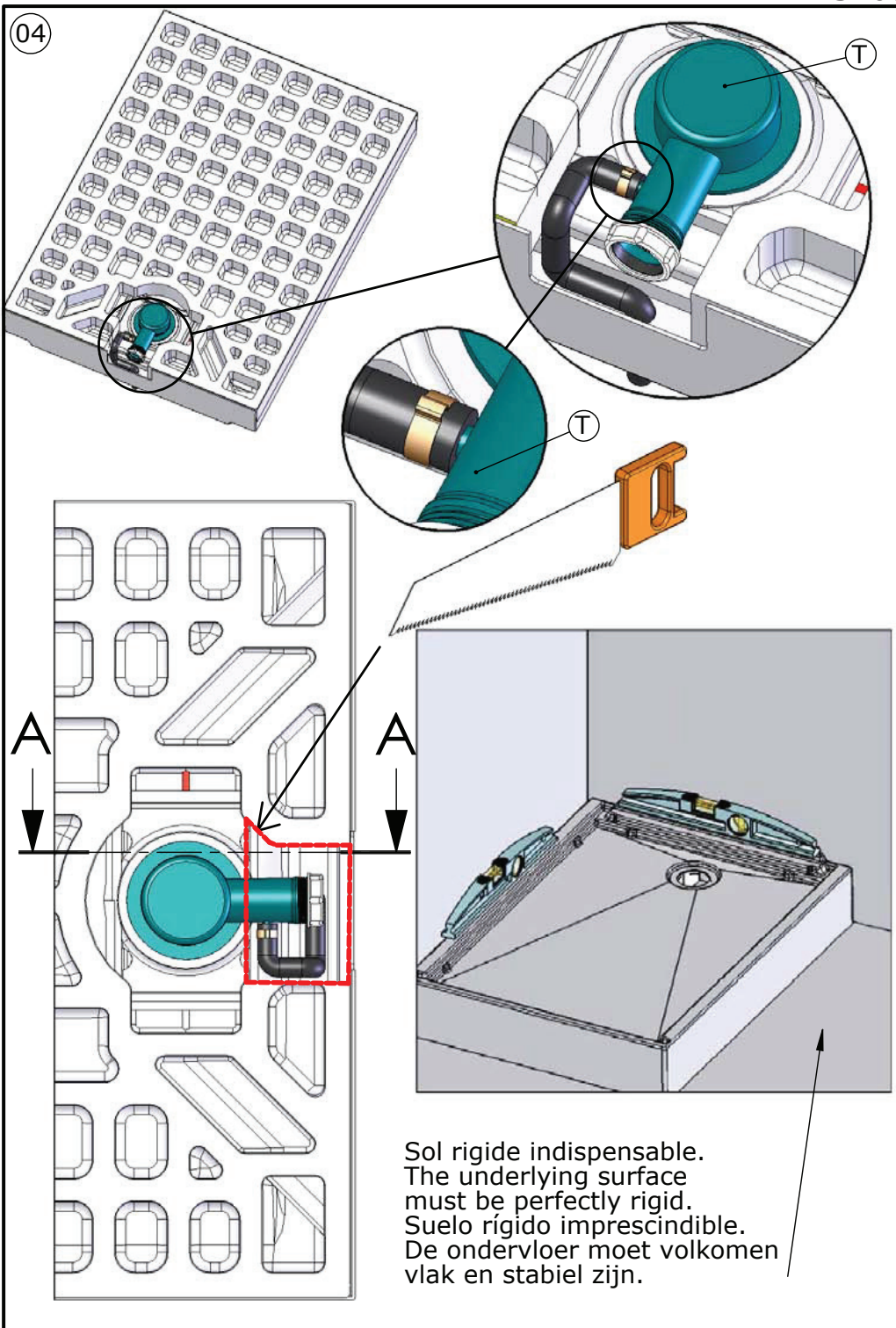

05

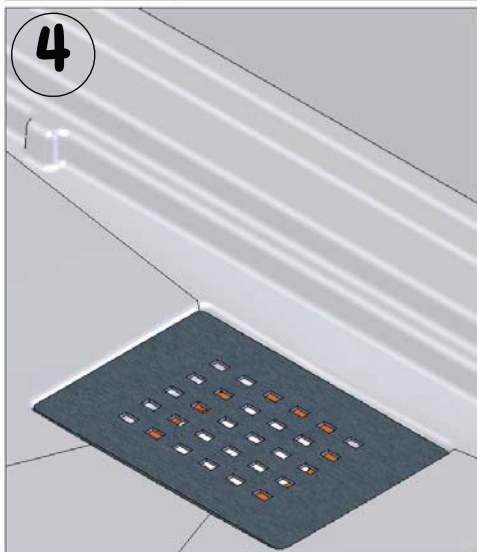
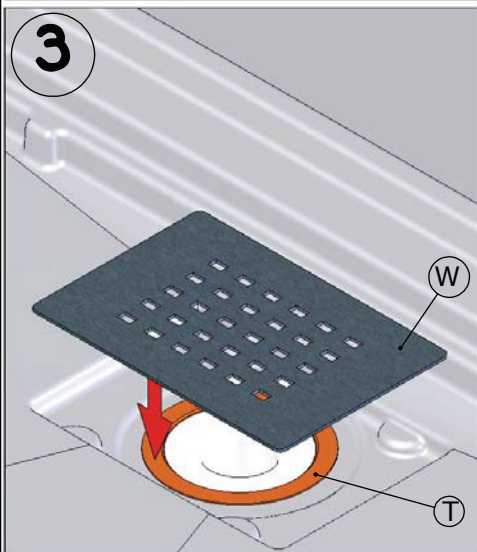
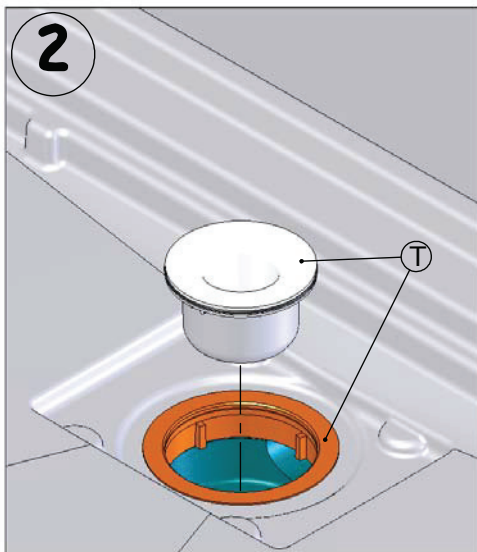
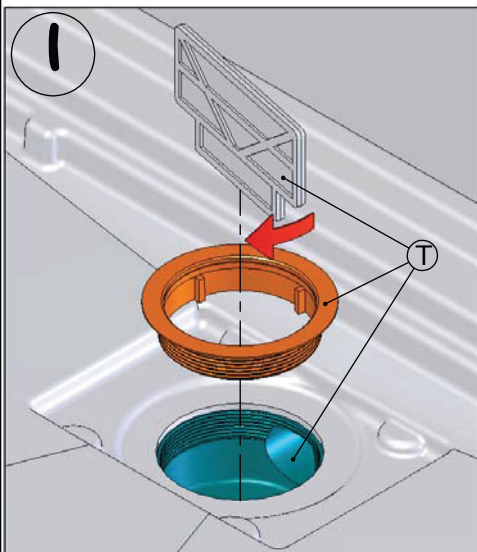

06

Sérigraphie à l'extérieur.  
Screen printing on the outside.  
Impresión en el fuera.  
Glas-print aan buitenzijde.

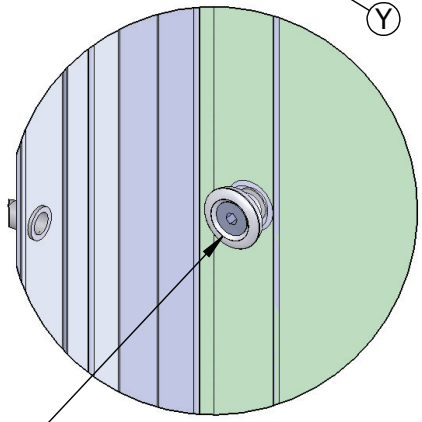
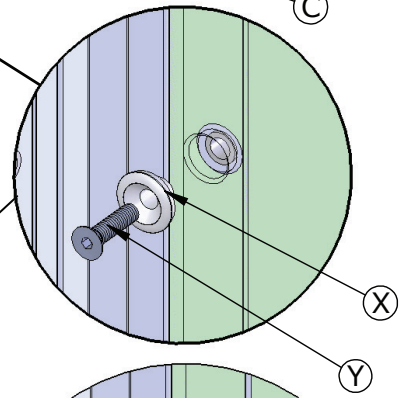
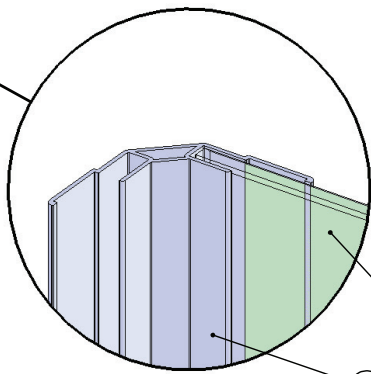
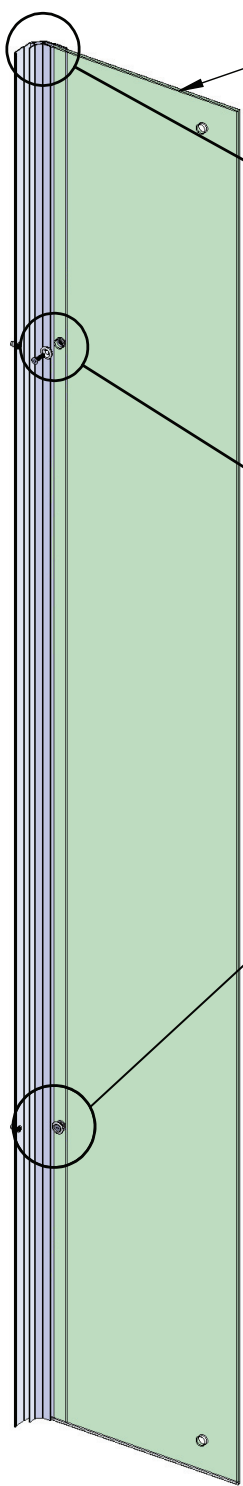

Ne pas serrer.  
Do not overtighten.  
No apriete.  
Niet vastschroeven.

- 07 Sérigraphie à l'extérieur.  
Screen printing on the outside.  
Impresión en el fuera.  
Glas-print aan buitenzijde.

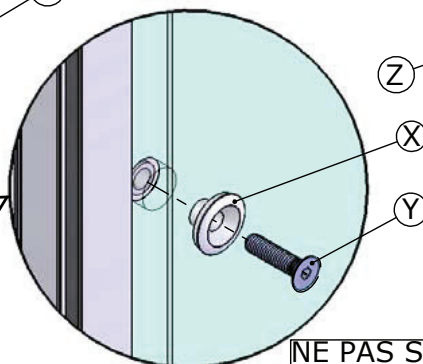
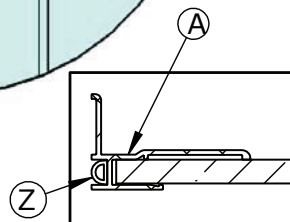
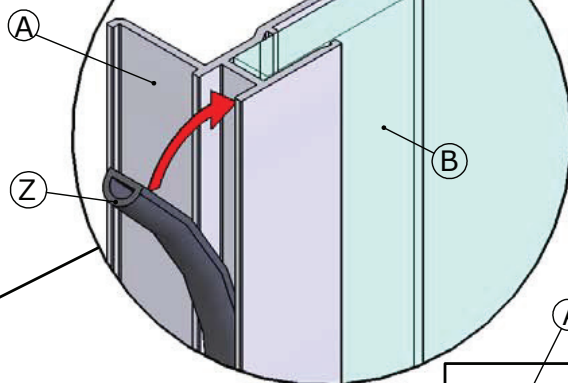

NE PAS SERRER.  
DO NOT OVERTIGHTEN.  
NO APRIETE.  
NIET VASTSCHROEVEN.

08

Sérigraphie à l'extérieur.  
Screen printing on the outside.  
Impresión en el fuera.  
Glas-print aan buitenzijde.

Fixer d'abord le grand panneau.  
Fix the big panel in first.  
En primer lugar asegurar el panel de gran tamaño.  
Eerst het grote paneel.

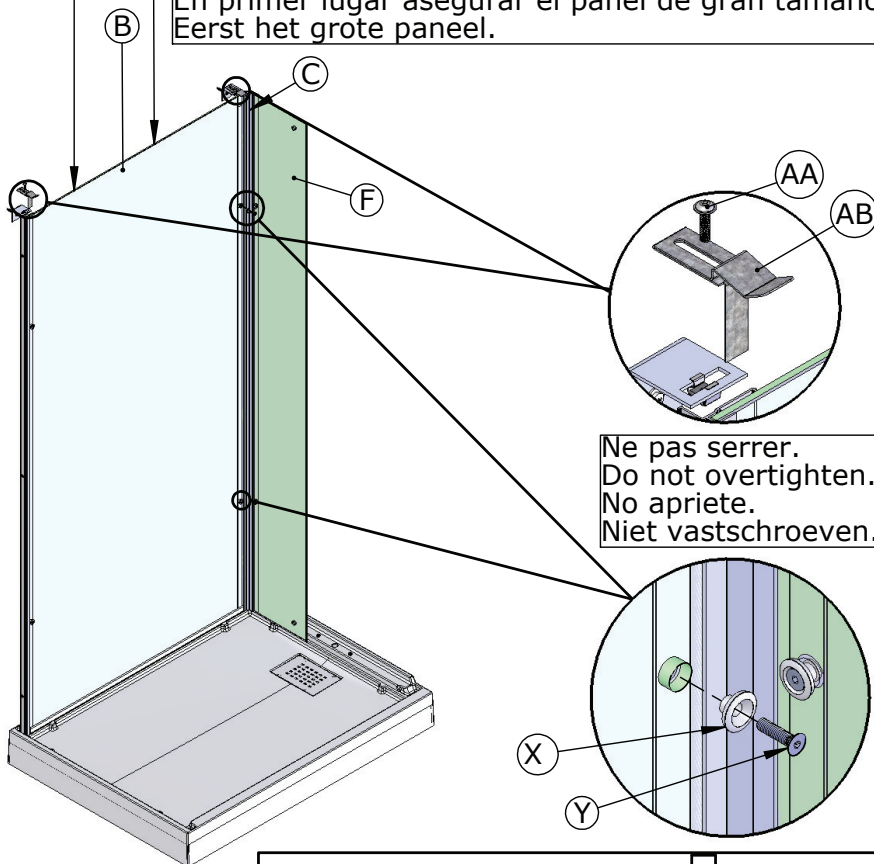

Ne pas serrer.  
Do not overtighten.  
No apriete.  
Niet vastschroeven.

Alignés.  
Align.  
Alineados.  
Op 1 lijn.

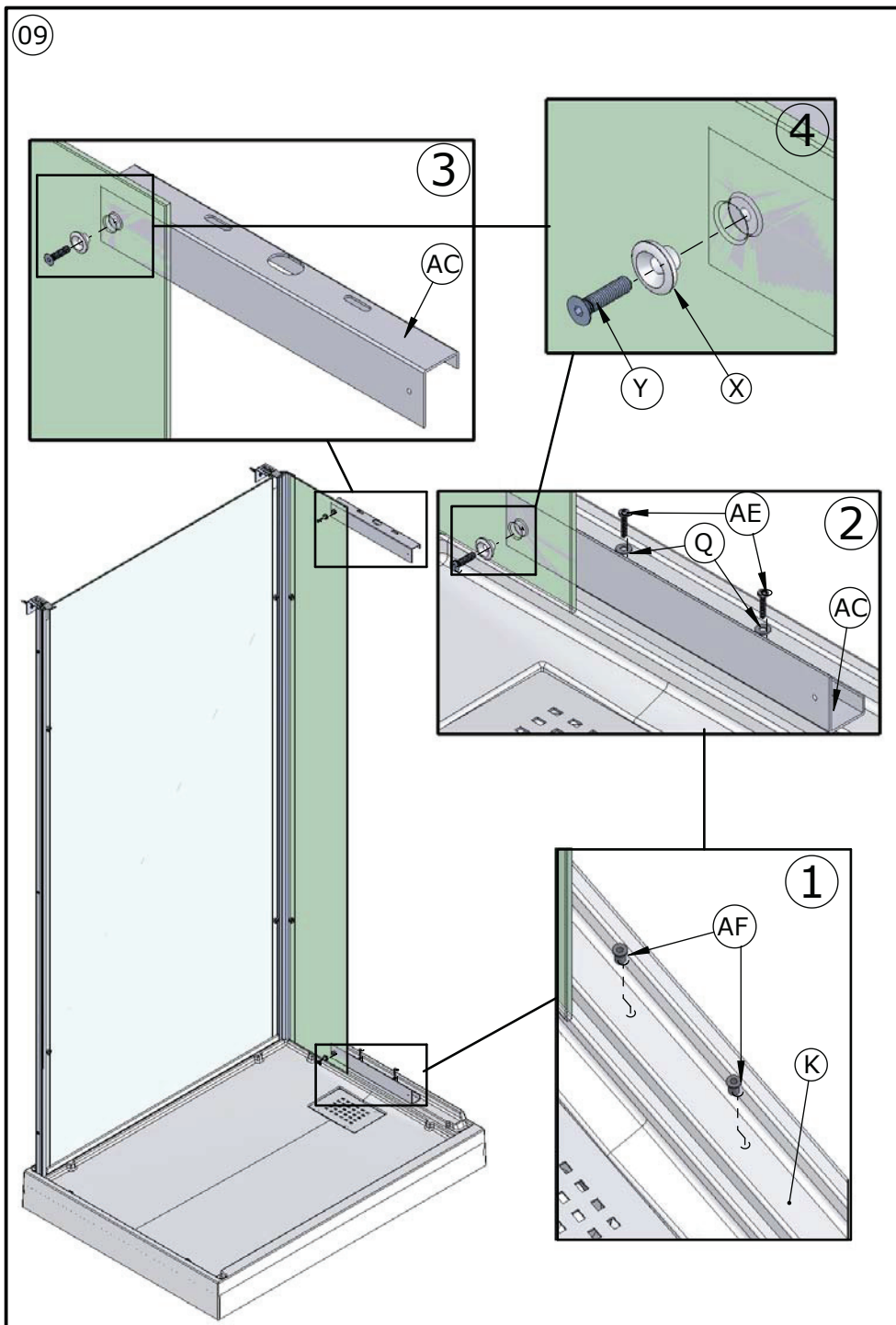

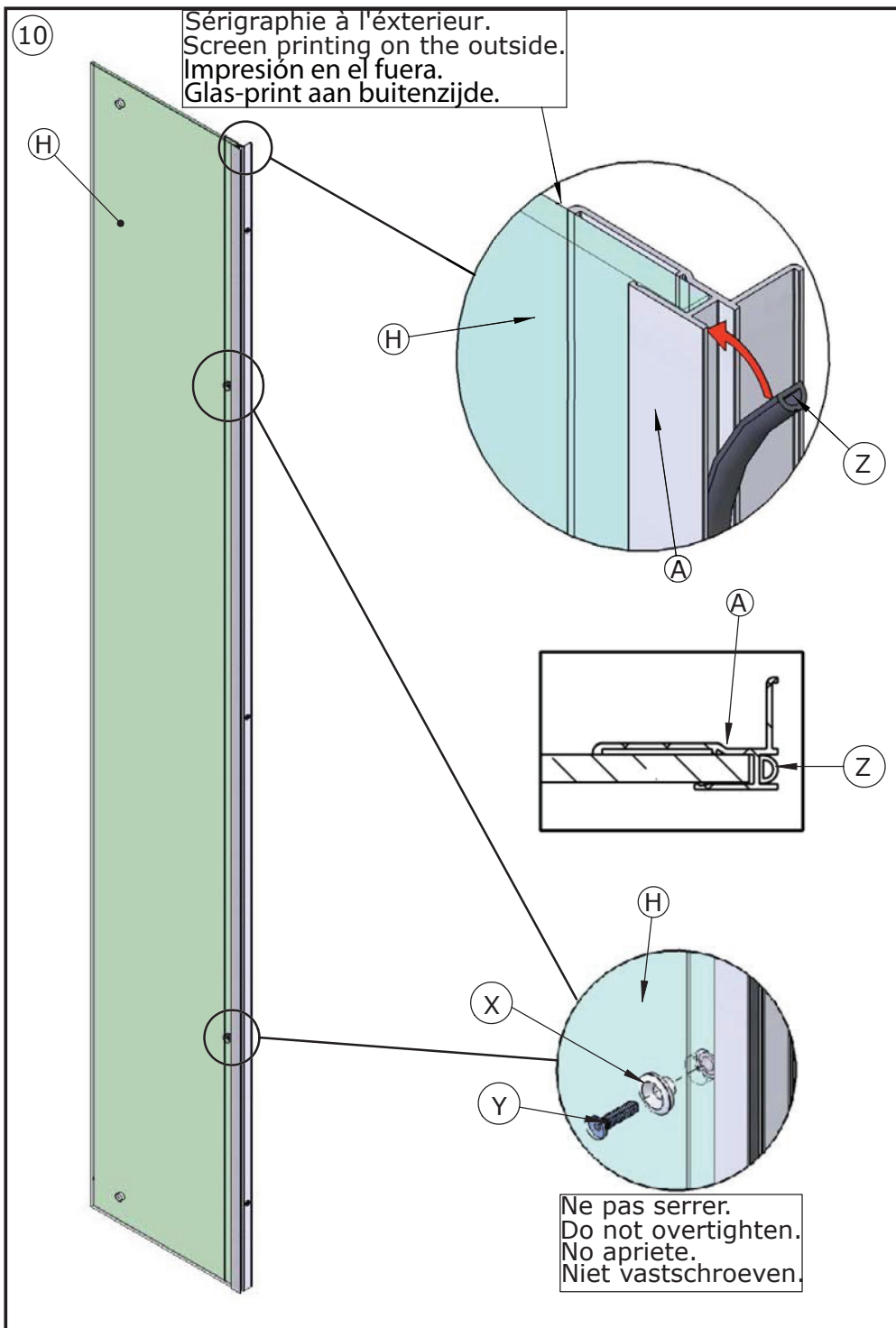

11

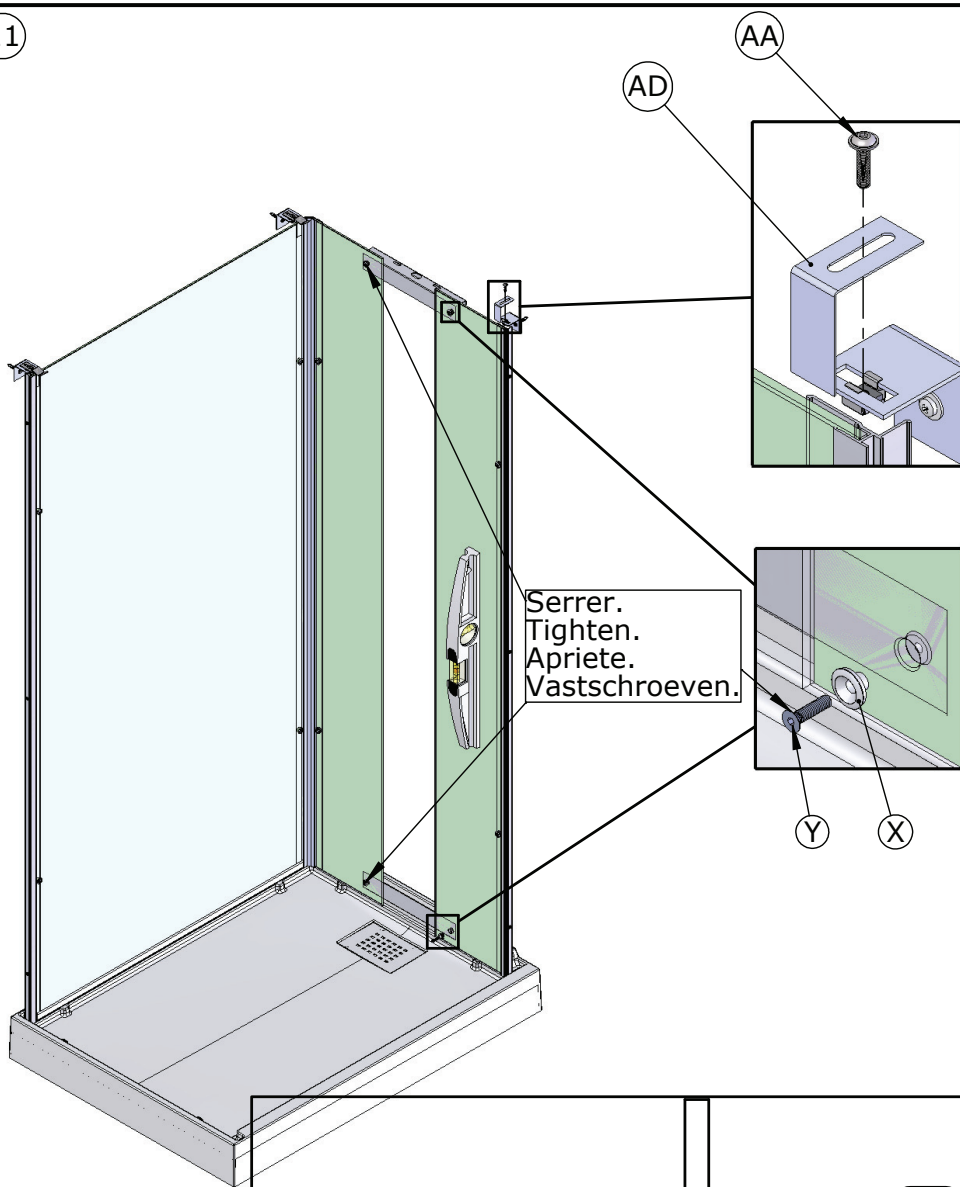

Serrer.  
Tighten.  
Apriete.  
Vastschroeven.

Y

X

Alignés.  
Align.  
Alineados.  
Op 1 lijn.



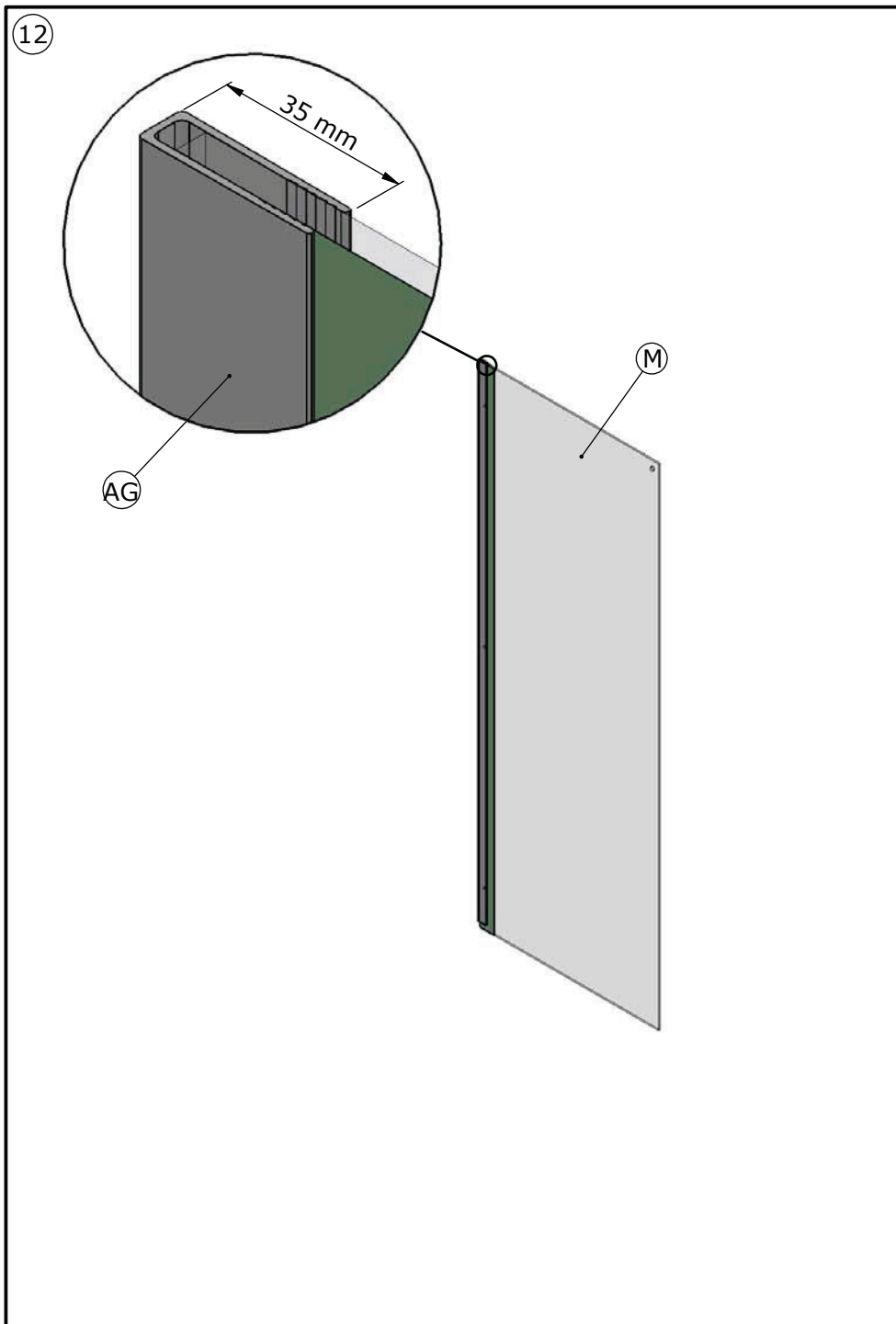

13

Perçage en haut.  
 Drill hole on top.  
 Perforazione en la parte superior.  
 Gaatje bovenaan.

AG

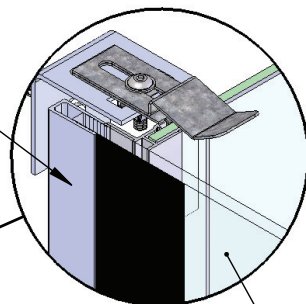

M

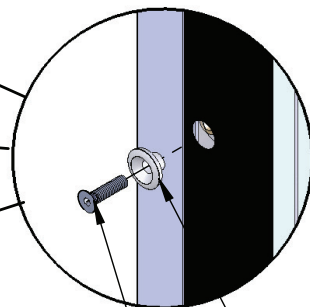
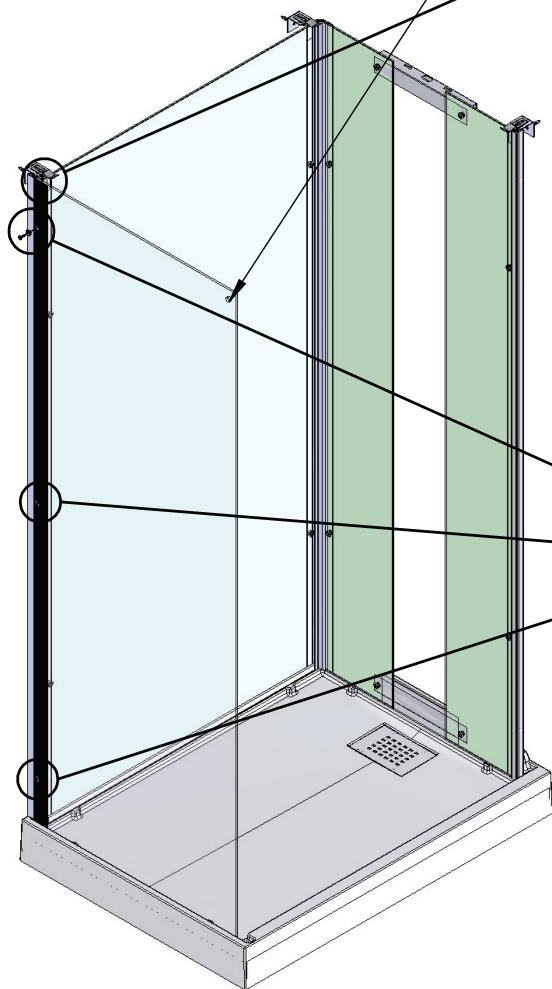

Y

X

Ne pas serrer.  
 Do not overtighten.  
 No apriete.  
 Niet vastschroeven.

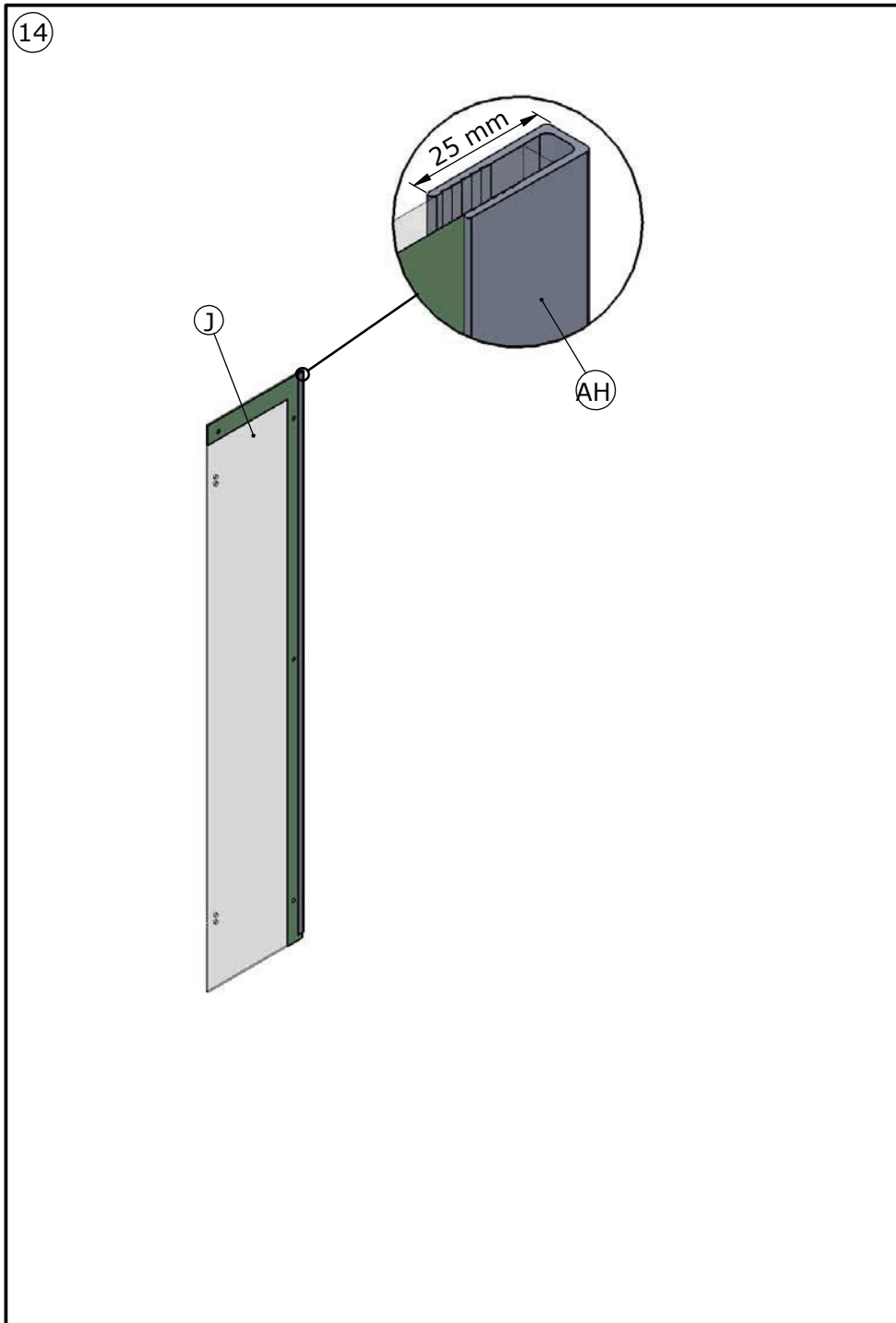

15

Perçages en haut.  
Drill holes on top.  
Perforazione en la parte superior.  
Gaatje bovenaan.

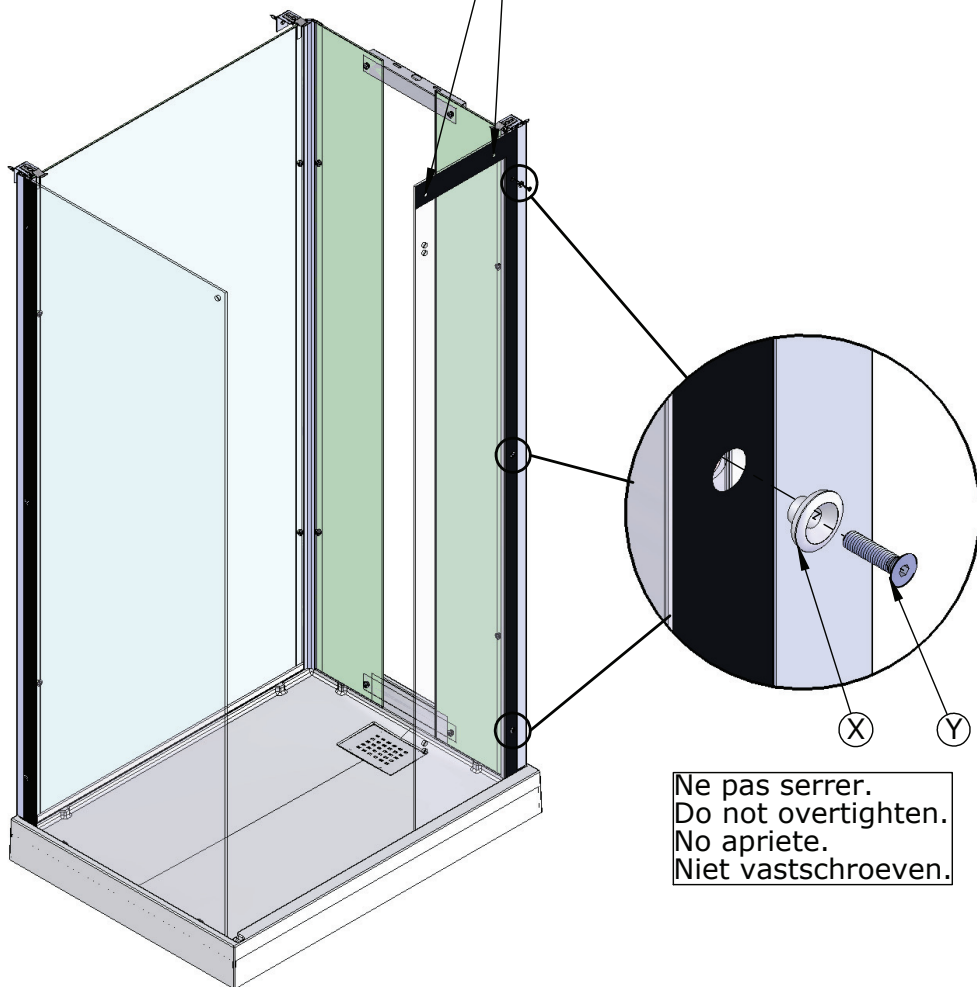

16

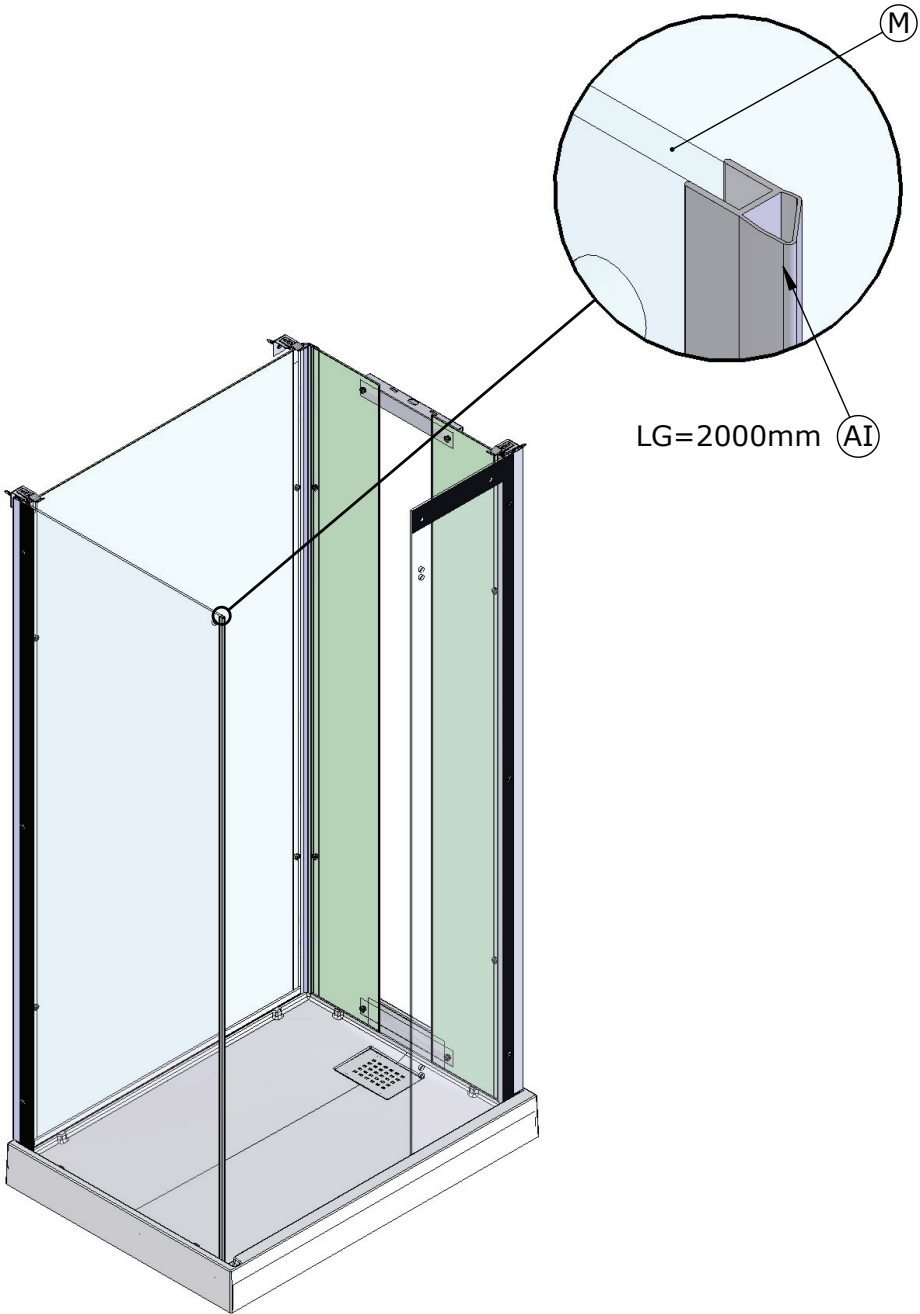

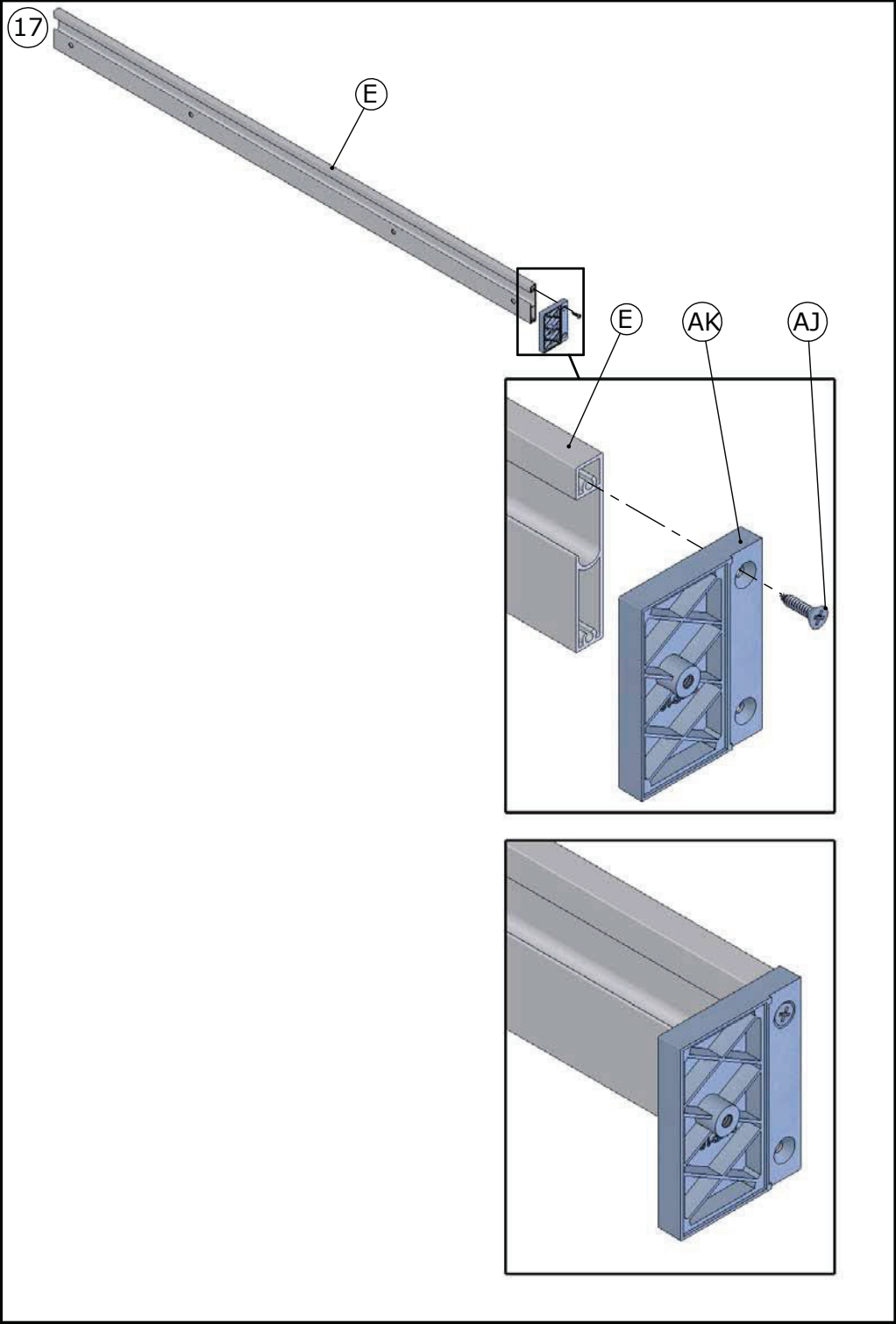

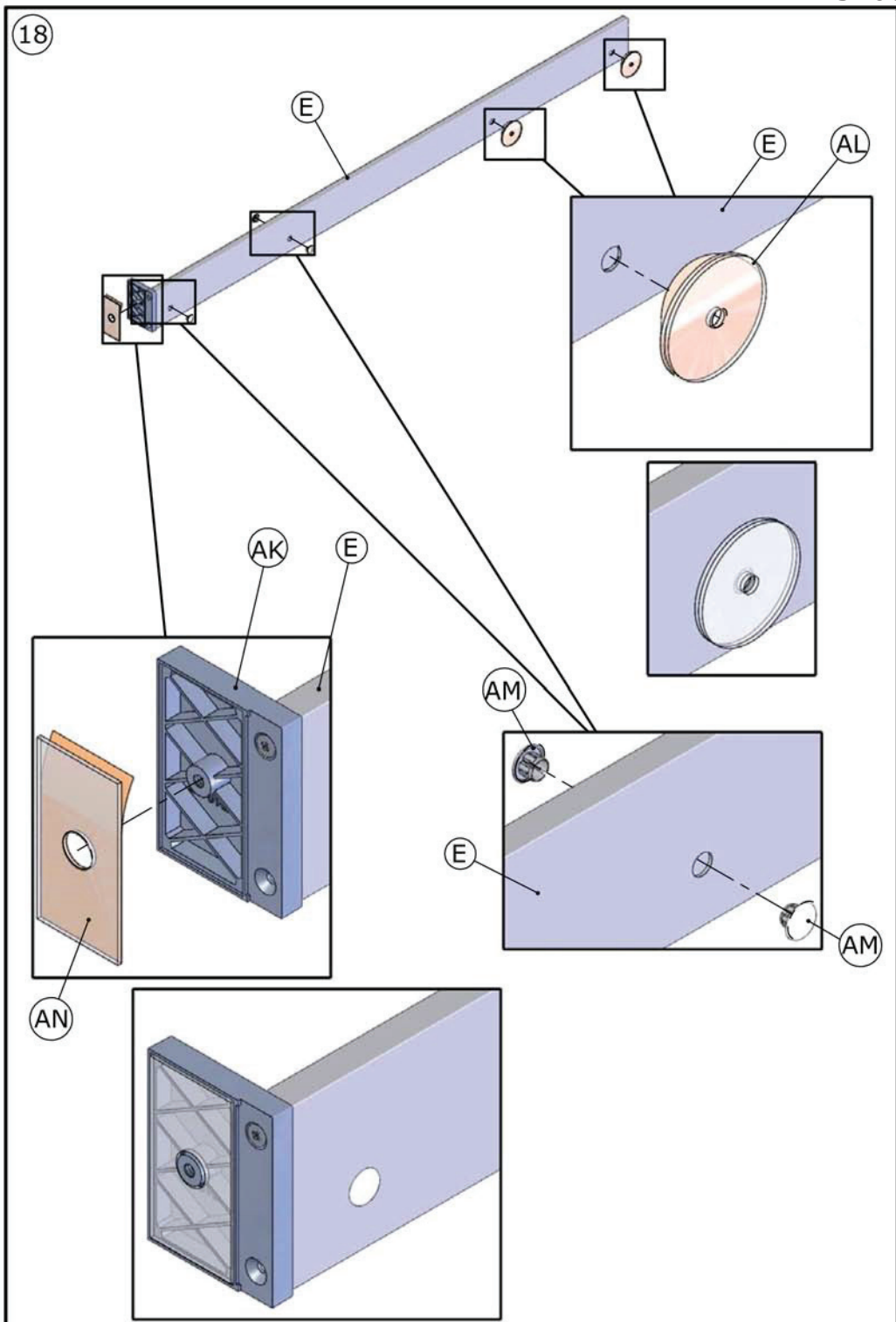

19

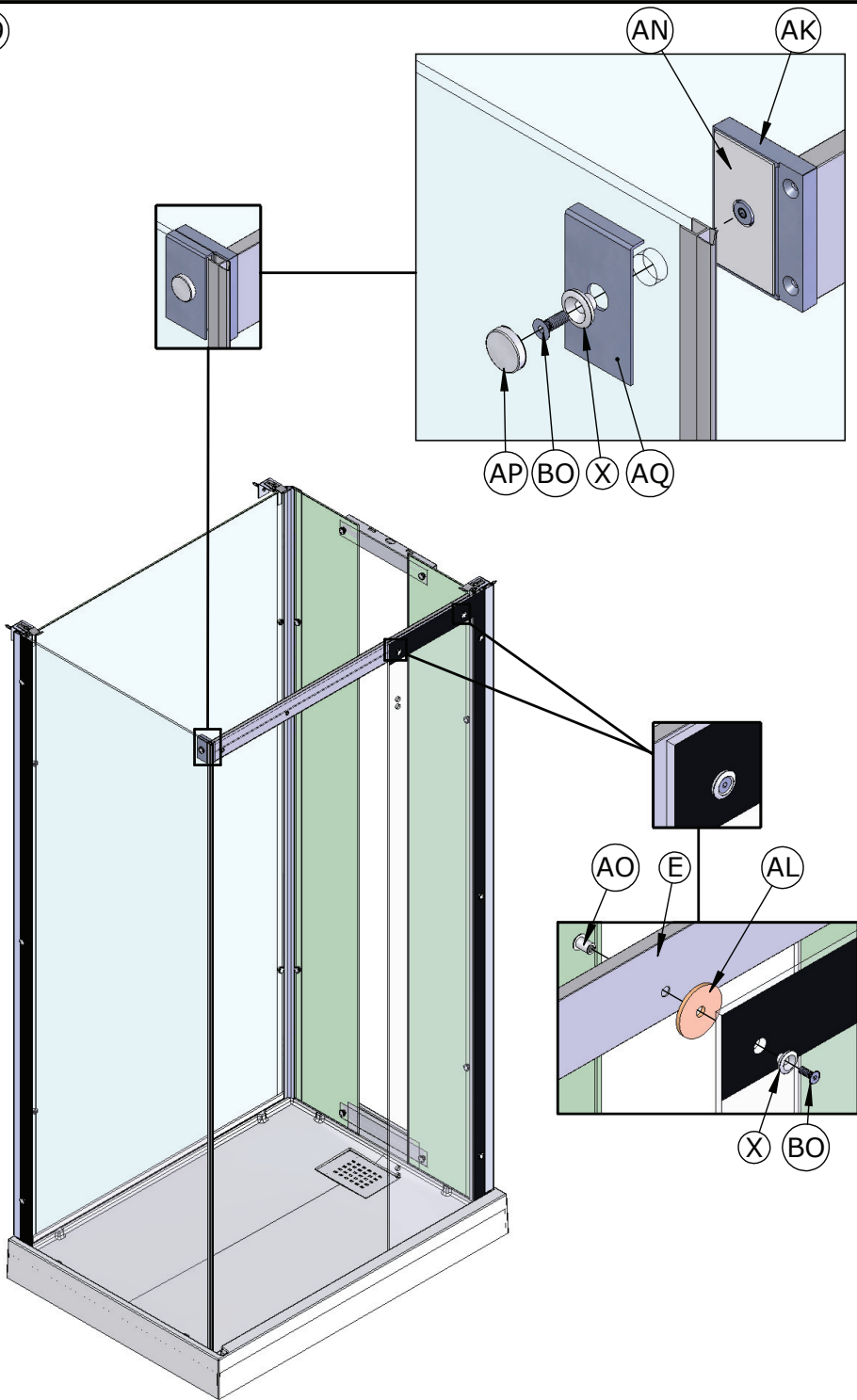



20

Gabarit de positionnement.  
 Template for the correct positioning.  
 Plantilla de posicionamiento.  
 Mal voor positionering.

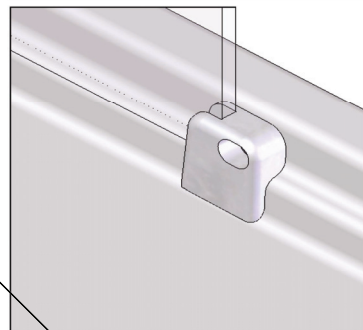
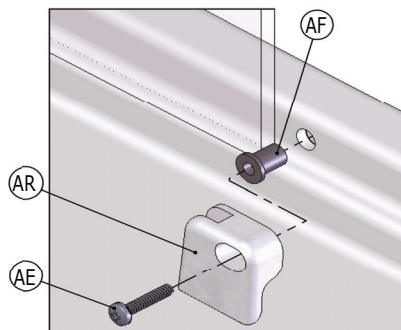
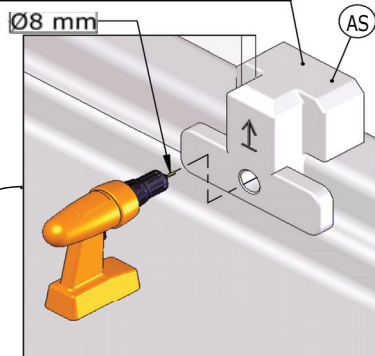
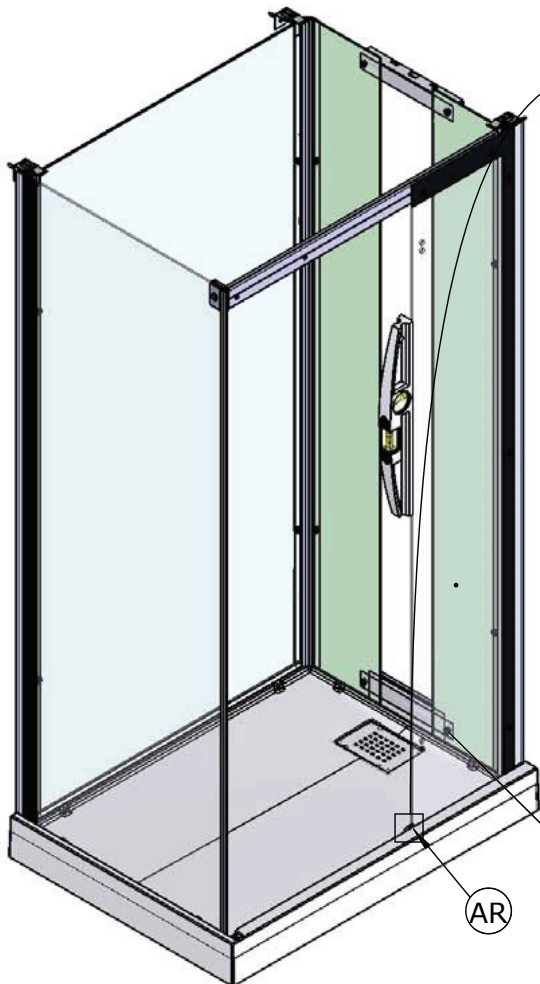

Assurez-vous que le verre soit bien en appui dans le fond du receveur avant de percer.  
 Ensure glass panels are fully home before drilling.  
 Posicionar el vidrio al fondo de el plato antes de perforar.  
 Controleer of het glas correct op de douchebak staat voordat u gaat boren.

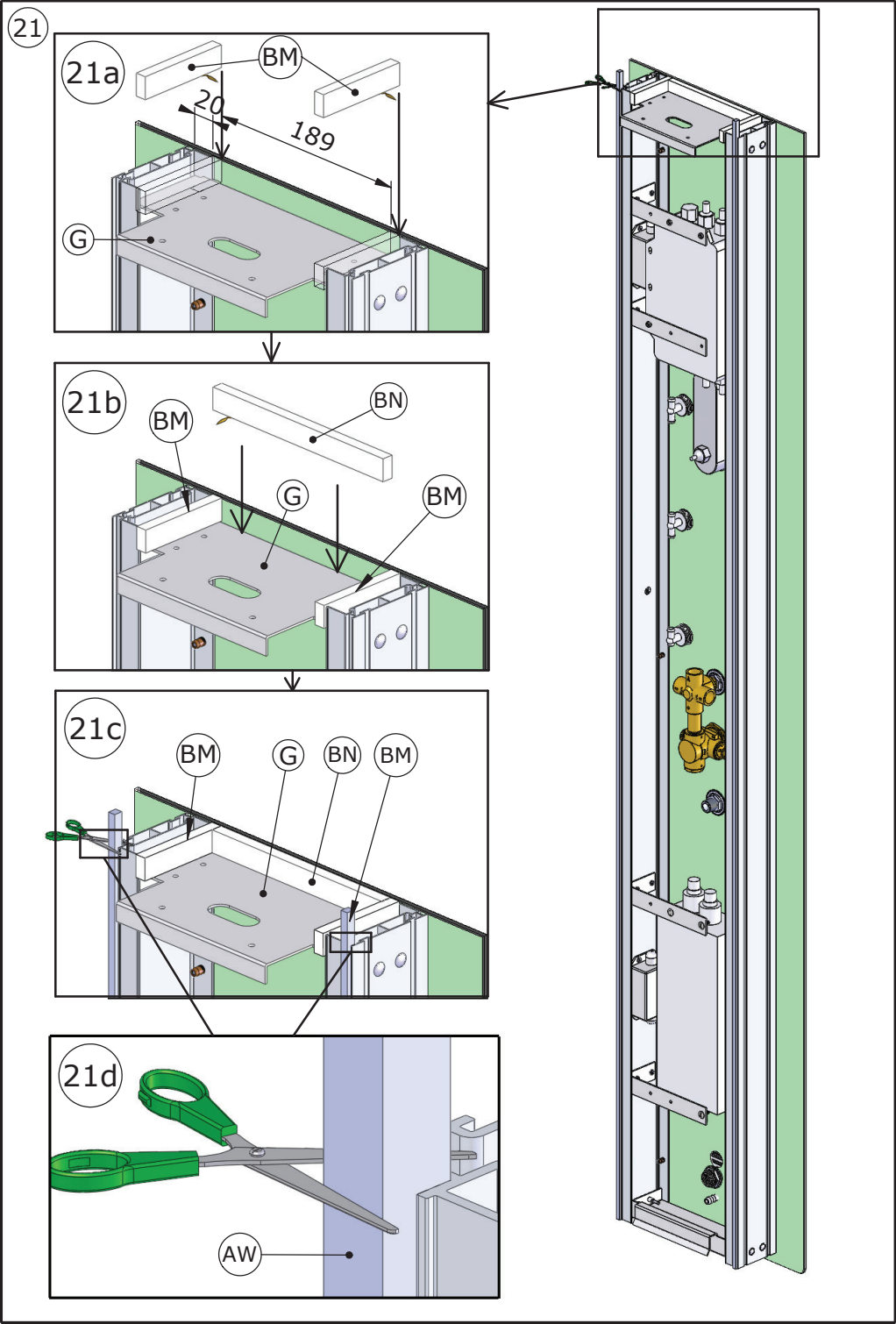

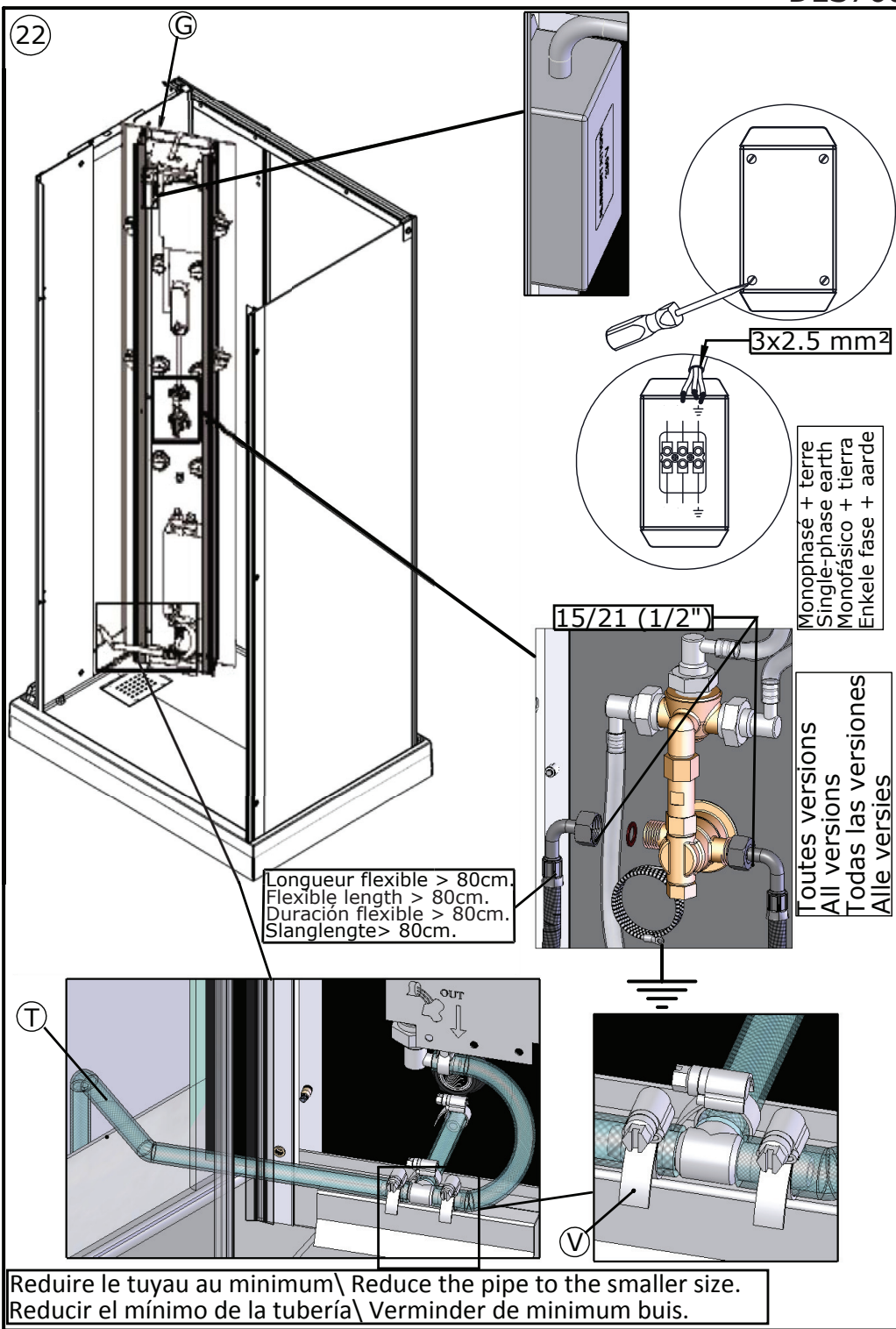

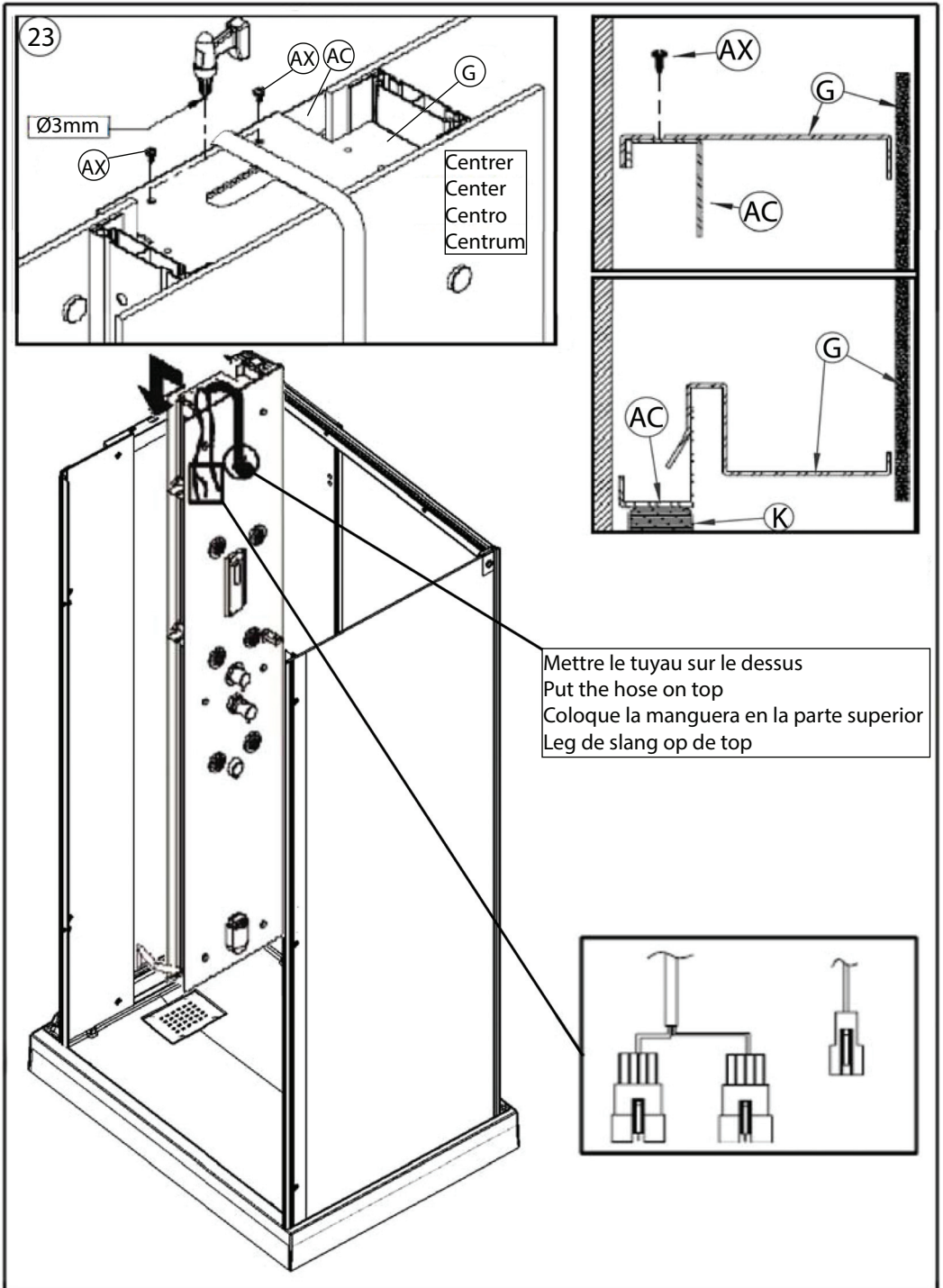

23

Ø3mm

AX

AX

AC

G

Centrer  
Center  
Centro  
Centrum

AX

G

AC

G

AC

K

Mettre le tuyau sur le dessus  
Put the hose on top  
Coloque la manguera en la parte superior  
Leg de slang op de top

24

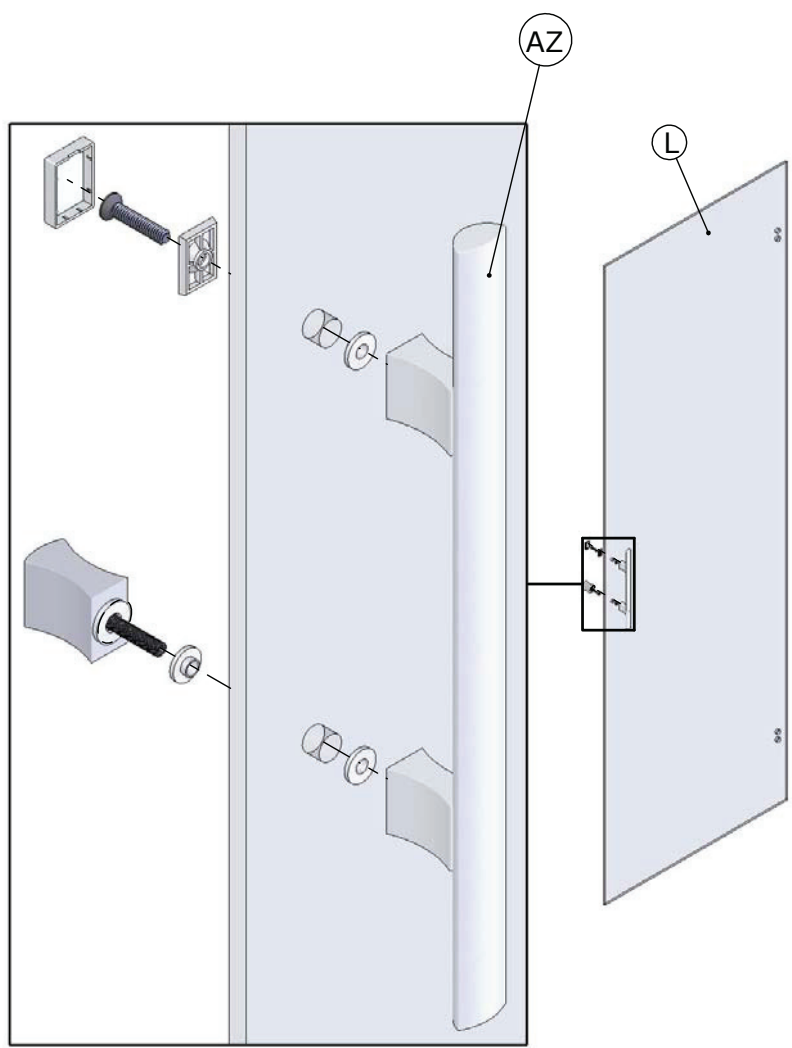

25

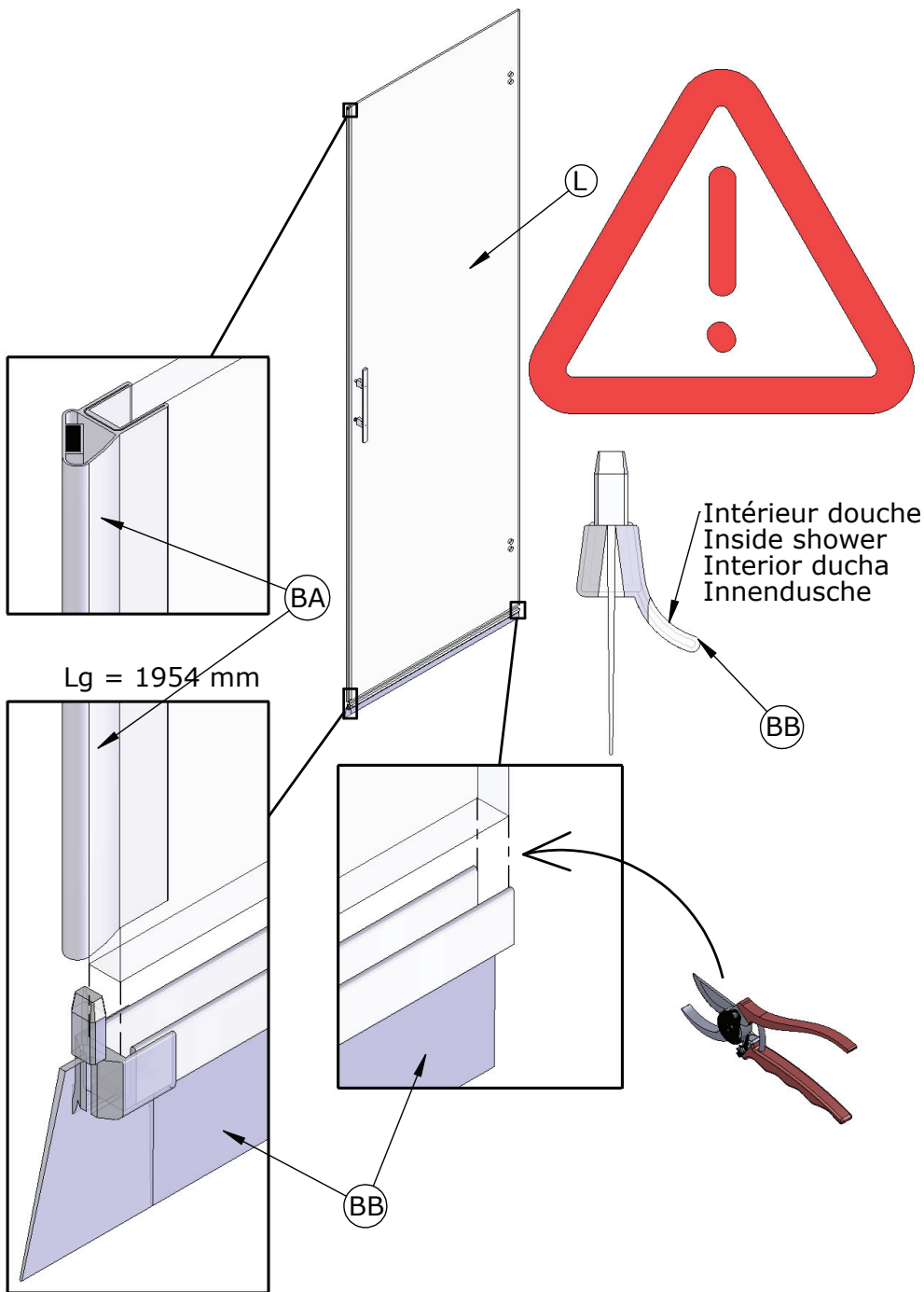

26

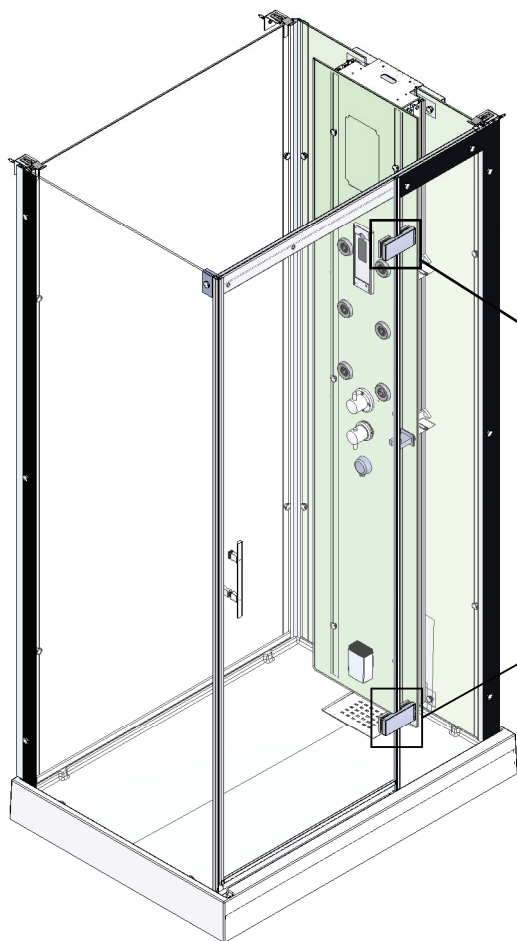

Voir notice concernée  
See note concerned  
Ver manual adecuado  
Zie de bijbehorende  
installatie-instructies

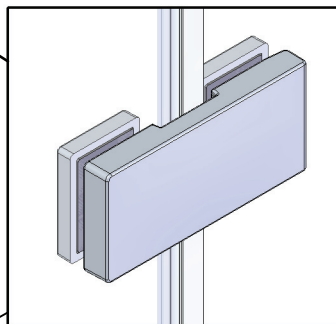

27

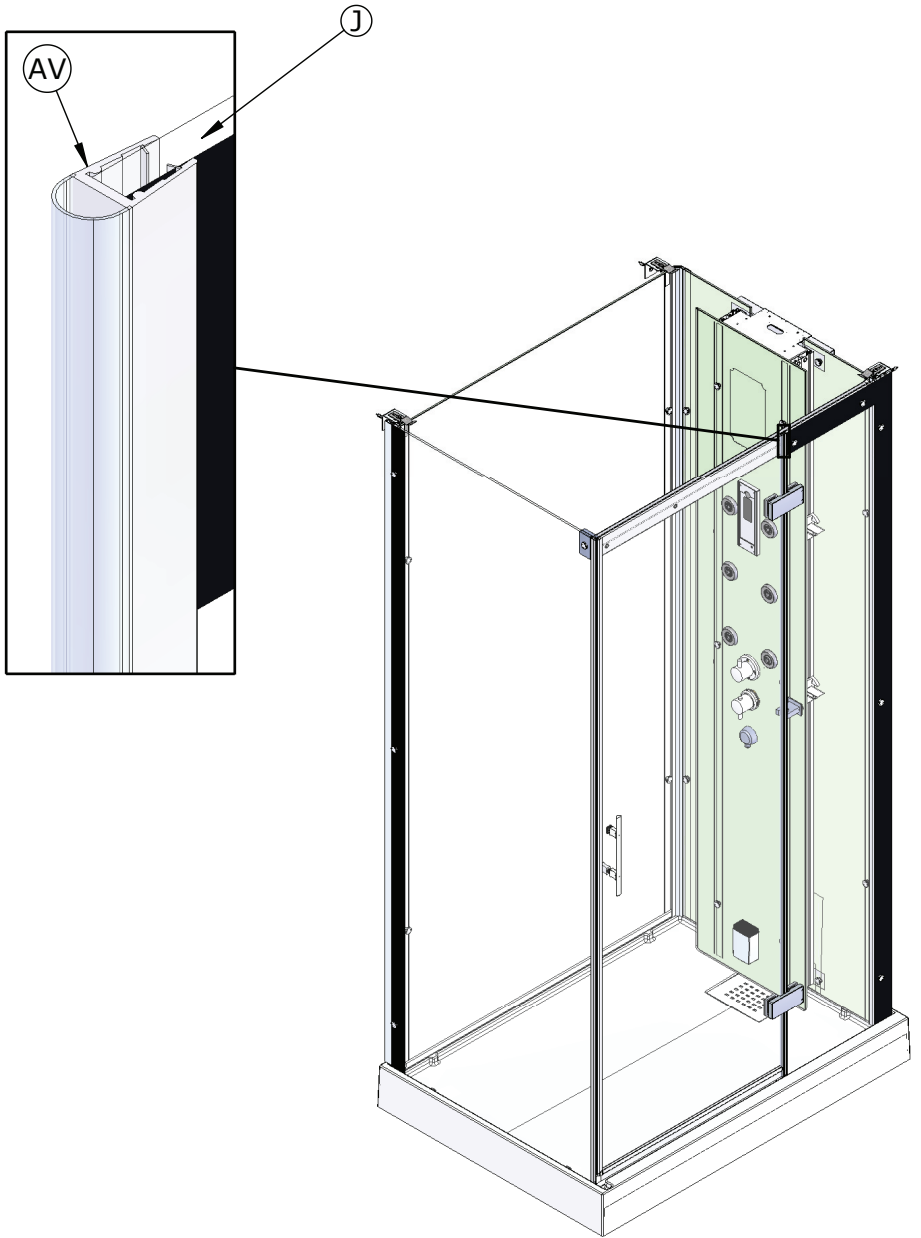



28

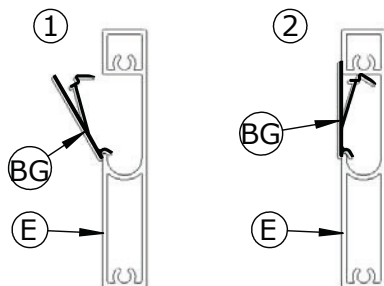
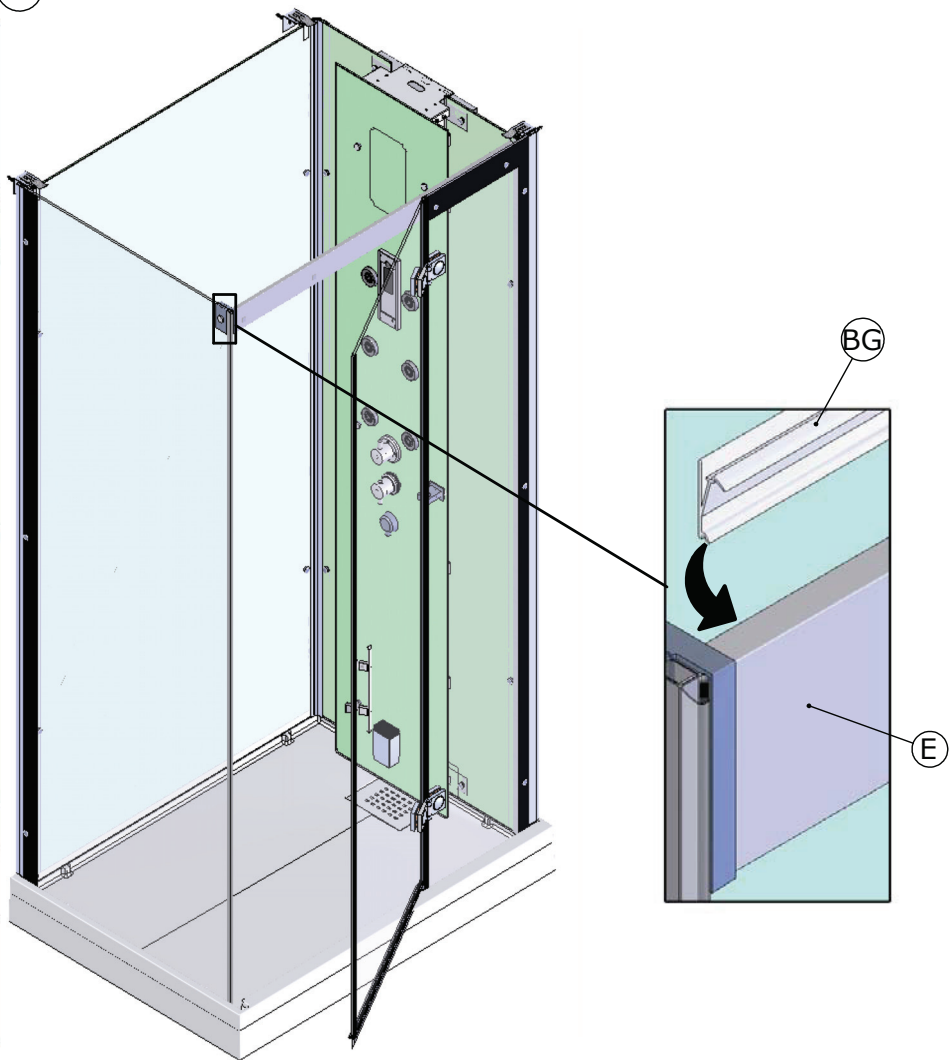

29

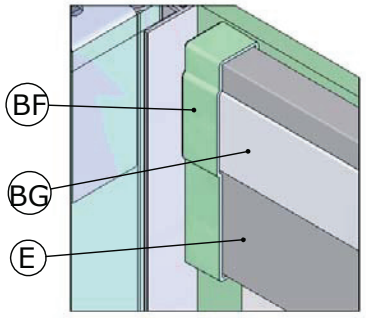
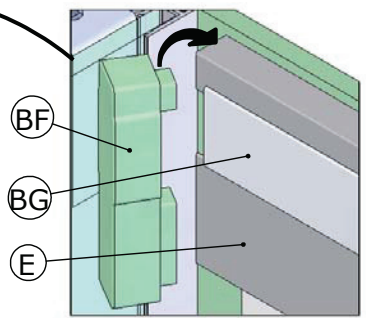
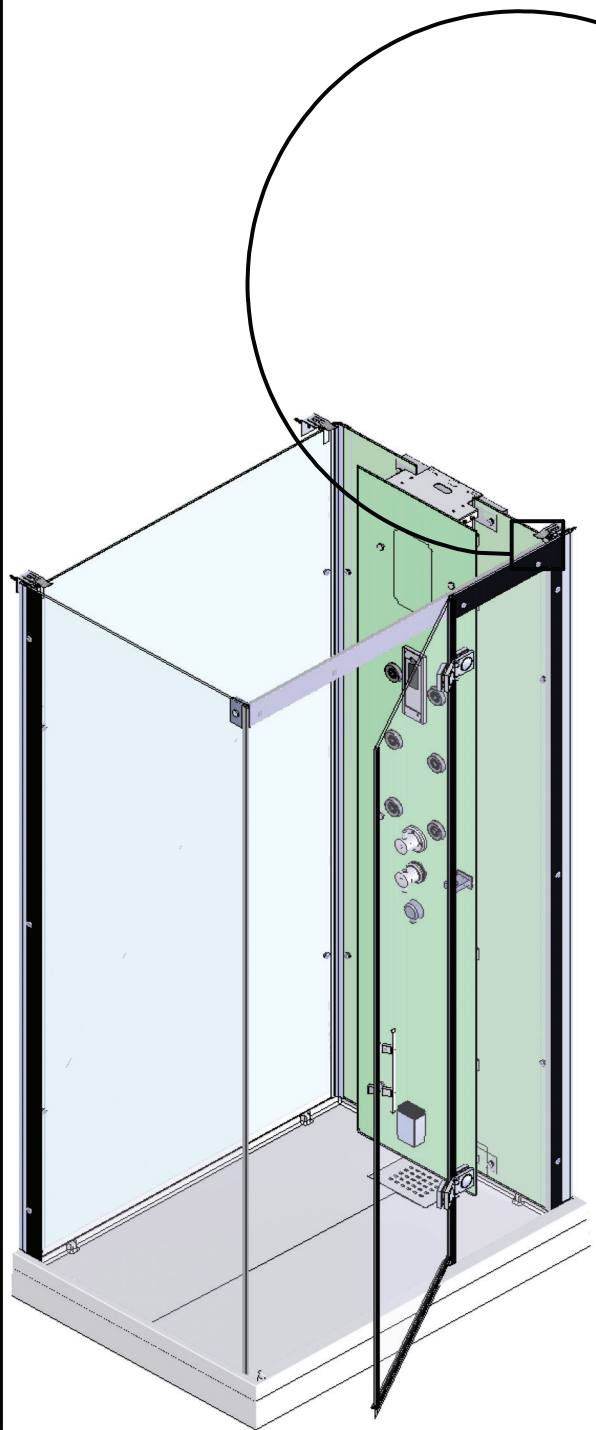

30

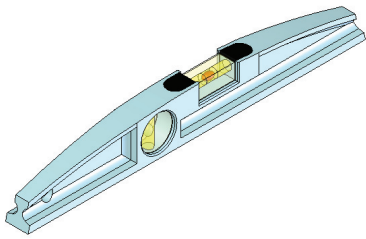

Vérifier l'aplomb de la cabine  
Check that the cubicle is level  
Compruebe la seguridad de la cabina  
Controleer of de cabine waterpas staat

Serrer  
Tighten  
Apriete  
Vastschroeven

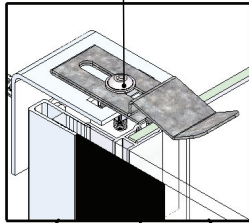

Serrer  
Tighten  
Apriete  
Vastschroeven

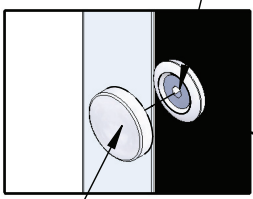

AP

X18

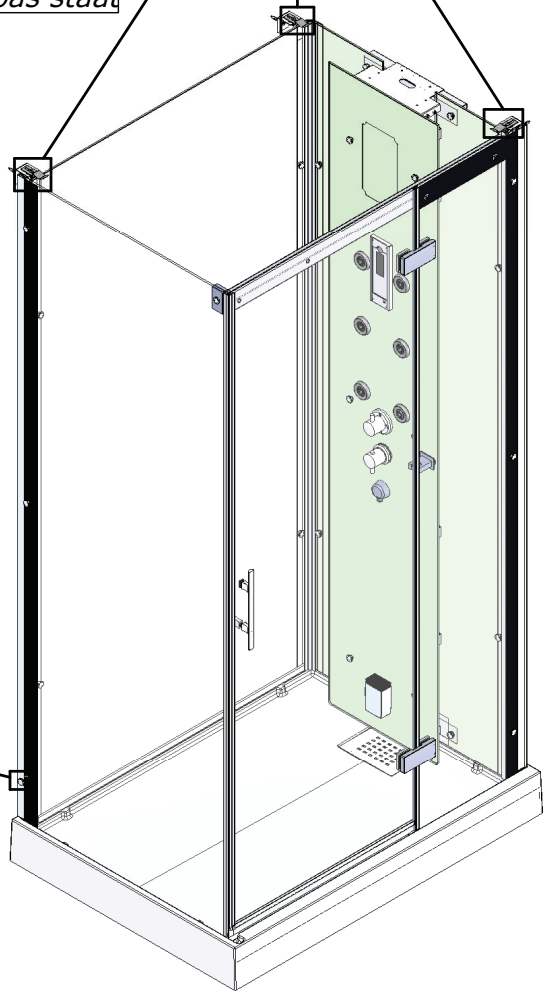

31

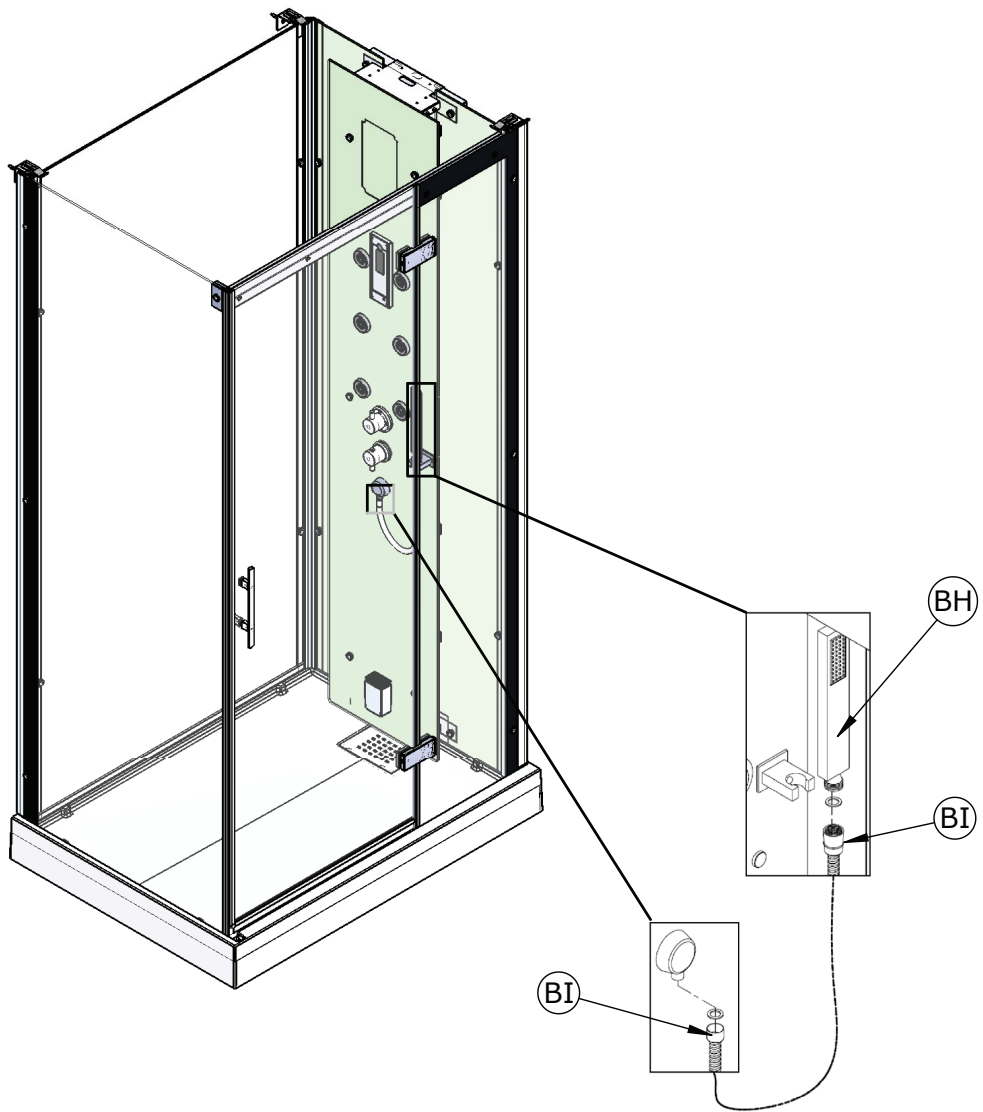

32

Voir la notice d'utilisation et d'entretien  
See instructions of use and maintenance  
Ver las instrucciones de uso y mantenimiento  
Zie de instructies voor gebruik en onderhoud

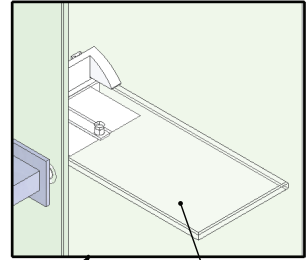

BJ

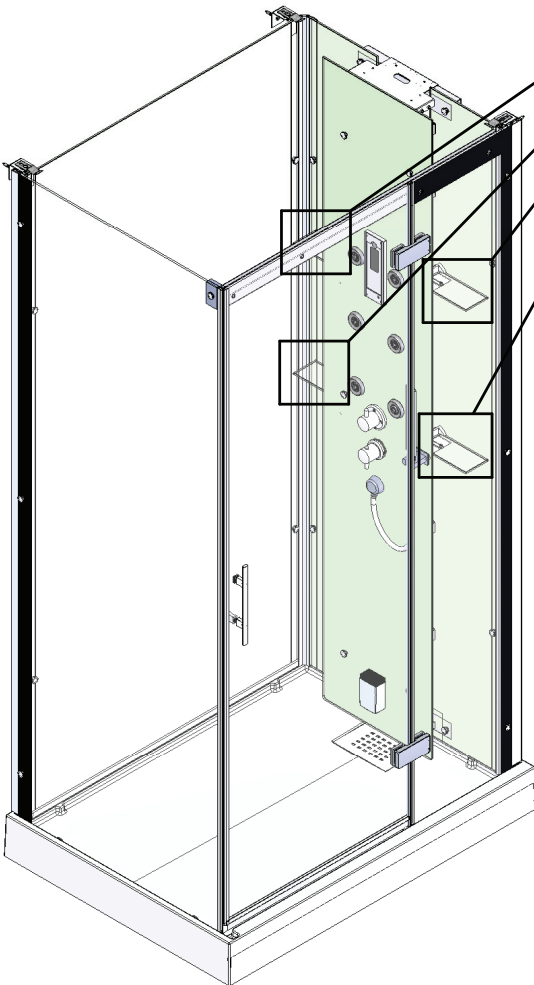

33

Fixer la coiffe sous les équerres.  
 Fix the panel thermoformed under the brackets.  
 Fijar el panel de termoformado en los soportes.  
 Bevestig de thermisch paneel onder de beugels.

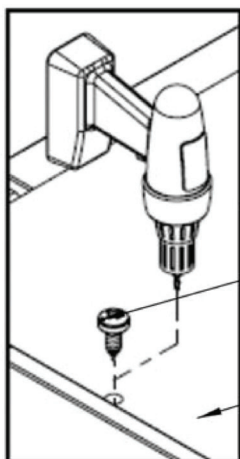
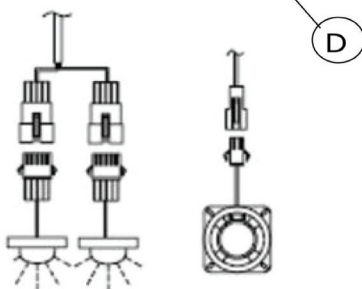
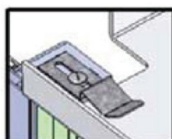
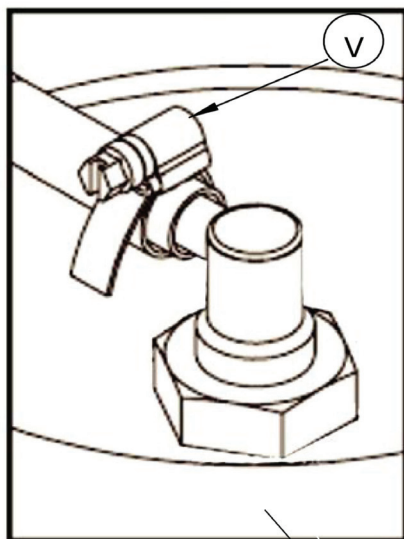

**Ø3 mm**

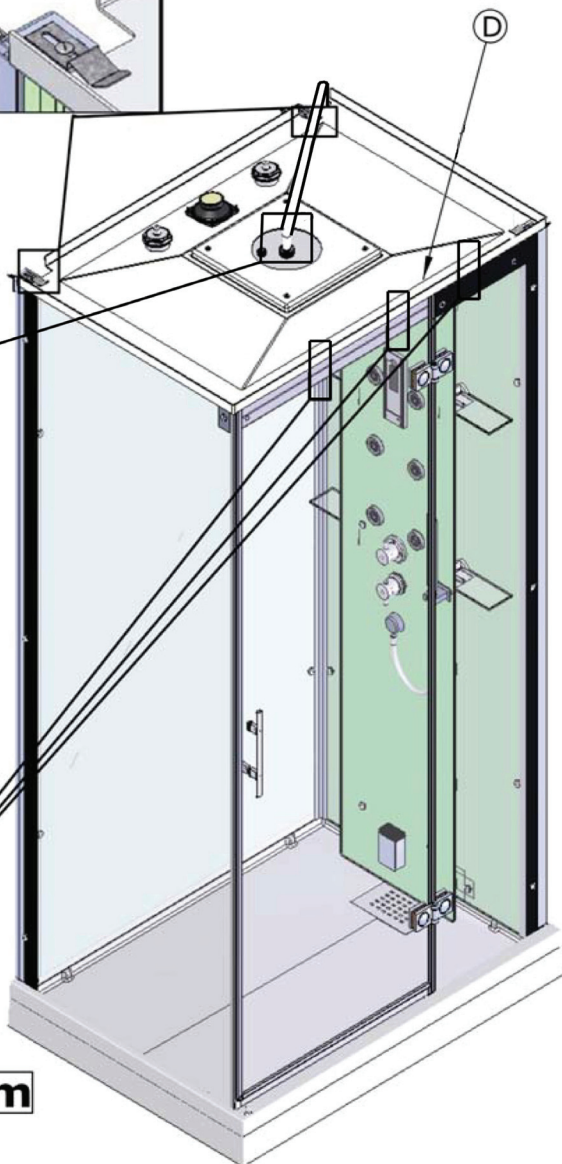

34

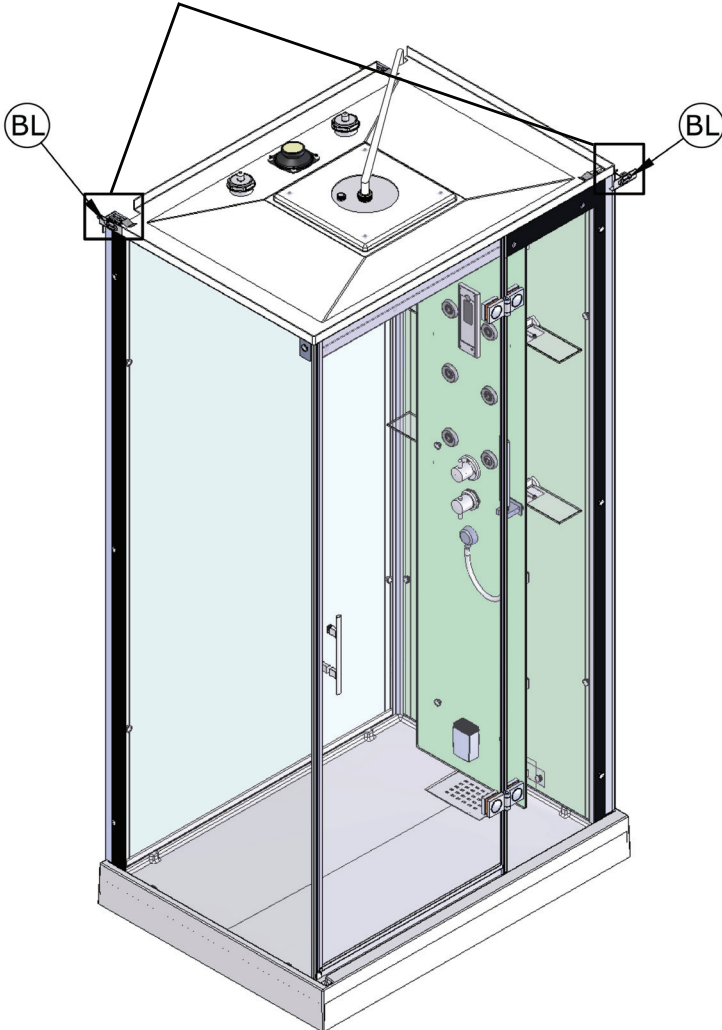
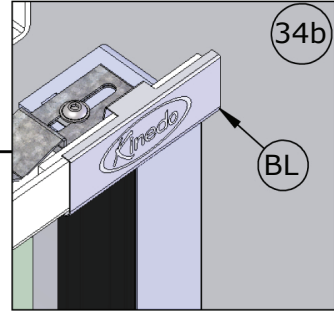
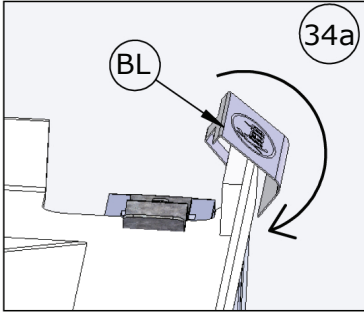



---

**-F-**

POUR LA PROTECTION ELECTRIQUE DE VOTRE DOUCHE, IL EST NECESSAIRE DE RELIER LES ORGANES METALLIQUES DE VOTRE PRODUIT AU CIRCUIT EQUIPOTENTIEL DE VOTRE INSTALLATION.

VOUS POUVEZ CONTACTER VOTRE INSTALLATEUR HABITUEL, IL SAURA VOUS CONSEILLER.

---

**-GB-**

FOR THE ELECTRONIC PROTECTION OF YOUR SHOWER, THE METAL PARTS OF YOUR PRODUCT SHOULD BE CONNECTED TO THE EQUIPOTENTIAL CIRCUIT OF YOUR INSTALLATION.

CONTACT YOUR USUAL SHOWER FITTER FOR ADVICE.

---

**-NL-**

VOOR DE ELEKTRISCHE BESCHERMING VAN UW DOUCHE MOETEN DE METALEN DELEN VAN UW PRODUCT WORDEN AANGESLOTEN OP HET EQUIPOTENTIALE CIRCUIT VAN UW INSTALLATIE.

NEEM HIERVOOR CONTACT OP MET UW NORMALE INSTALLATEUR, HIJ KAN U ADVISEREN.

---

**-I-**

PER GARANTIRE LA PROTEZIONE ELETTRICA DELLA DOCCIA OCCORRE COLLEGARE LE PARTI METALLICHE AL CIRCUITO EQUIPOTENZIALE DELL'APPARECCHIO.

CHIEDERE CONSIGLIO ALL'ELETTICISTA DI FIDUCIA

---

**-ES-**

PARA LA PROTECCIÓN ELÉCTRICA DE SU DUCHA, SERÁ NECESARIO CONECTAR LOS ELEMENTOS METÁLICOS DE SU PRODUCTO AL CIRCUITO EQUIPOTENCIAL DE SU INSTALACIÓN.

PÓNGASE EN CONTACTO CON SU INSTALADOR HABITUAL, ÉSTE SABRÁ ACONSEJARLE.

---







**NOTICE D'ENTRETIEN  
MAINTENANCE INSTRUCTIONS  
ISTRUZIONI DI MANUTENZIONE  
INSTRUCCIONES DE MANTENIMIENTO  
ONDERHOUDSINSTRUCTIE  
WARTUNGSANLEITUNG**



**SCAN ME**





## SERVICE APRÈS-VENTE AFTER-SALES SERVICE

### FRANCE

+33 (0)2 40 21 29 45

### UK

+44 (0)20 8842 0033

### IRELAND

+353 04697 33102

### DEUTSCHLAND

+49 (0) 6074 / 30928 0

### ITALIA

+39 (0382) 6181

### ÖSTEREICH

+43 1 710 60 70

### SUISSE/SCHWEIZ

+41 (0)32 631 04 74

### ESPAÑA

+34 93 544 60 76

### NEDERLAND

+31 475 487 100

### BELGIQUE/BELGIË

+31 475 487 100

### РОССИЯ

+7 495 258-29-51

### PORTUGAL

+351 219 112 785