

Kinedo

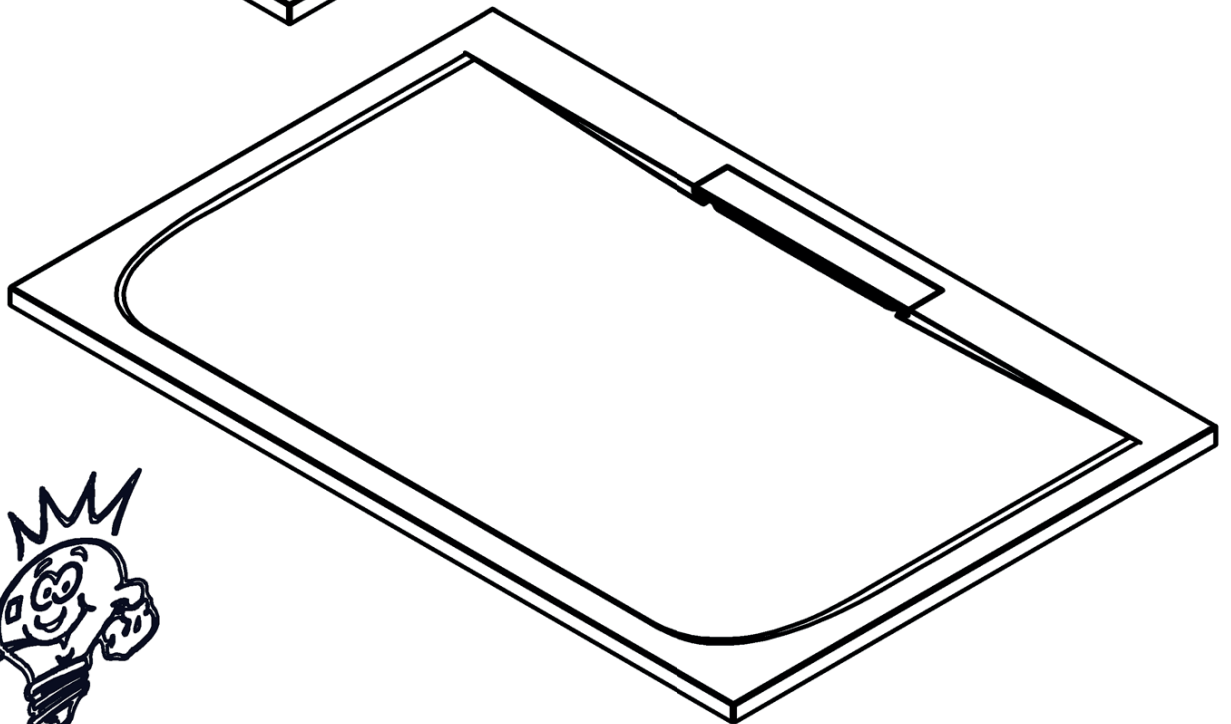
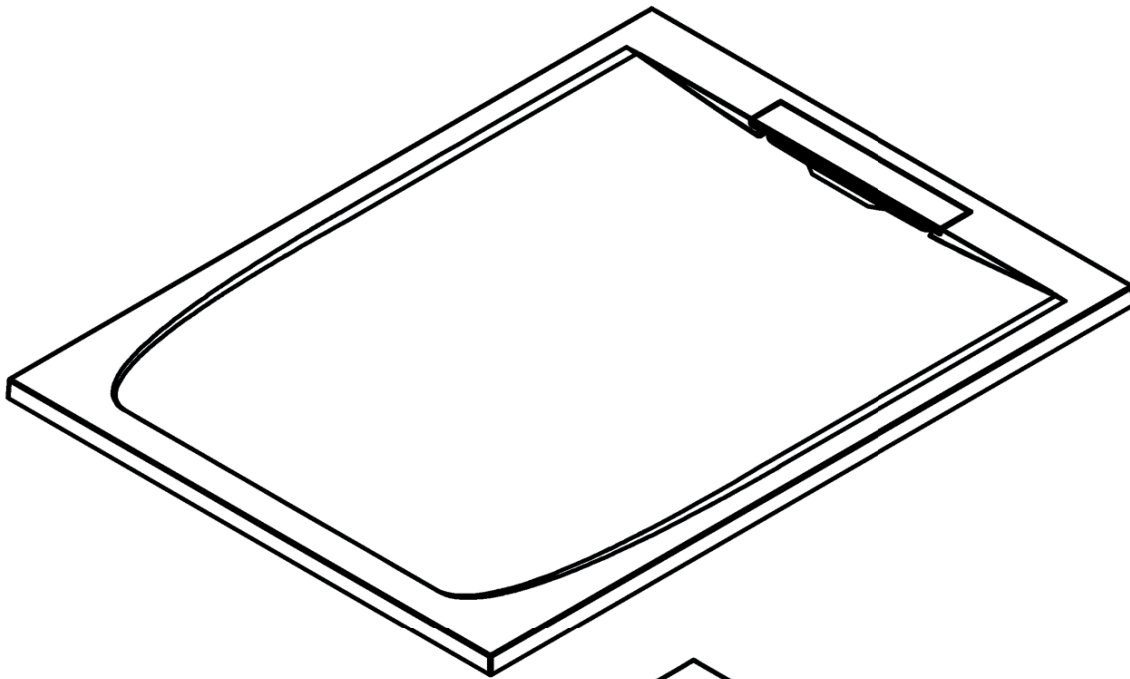

Notre service technique est
à votre écoute aux numéros
qui sont au dos de cette
notice d'installation

(A)

x1

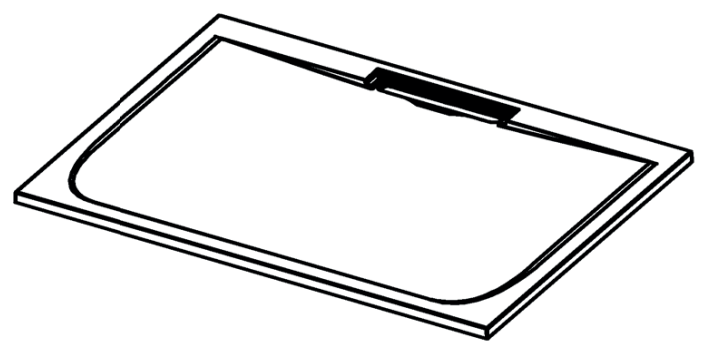
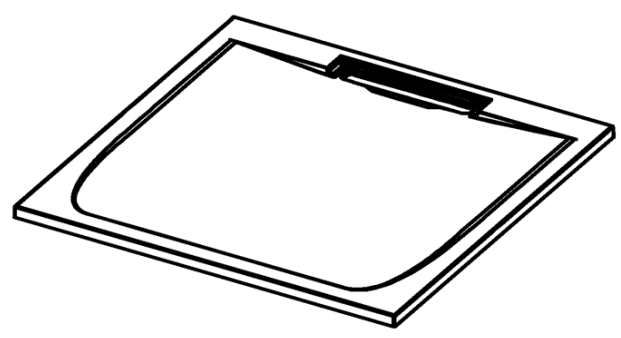

80x80	REC701
90x90	REC703

140x80	REC711	160x90	REC714
140x90	REC712	180x80	REC717
160x80	REC713	180x90	REC718

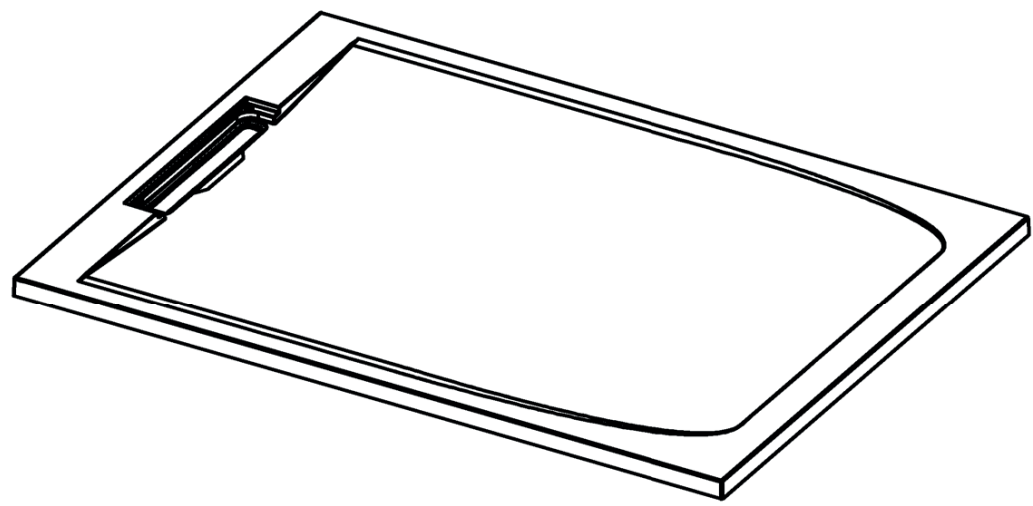

100x80	REC820	120x80	REC822	140x80	REC824	160x80	REC826	180x80	REC828
100x90	REC821	120x90	REC823	140x90	REC825	160x90	REC827	180x90	REC829

(B)

x1

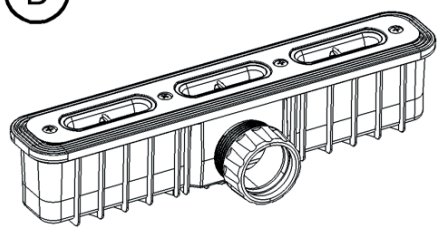

BOND39

(C)

x1

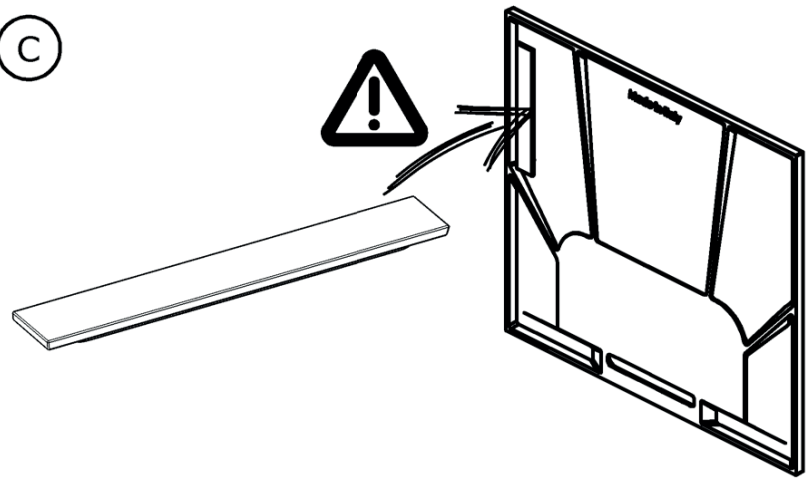

CAP27

FR - Les quantités données sont les quantités utiles au montage. les sachets fournis contiennent des pièces supplémentaires.
 GB - The quantities given are what are required for the installation. There may be some surplus in the package provide.
 ES - Las cantidades indicadas son las cantidades necesarias para el montaje. Las bolsitas incluidas contienen piezas suplementarias.
 PT - A quantidade indicada é a quantidade necessária para a montagem. As bolsas incluem peças adicionais.
 IT - Le quantità fornite sono le quantità necessarie al montaggio. I sacchetti forniti contengono pezzi supplementari.
 NL - De aangegeven aantallen zijn bestemd voor de montage. De bijgeleverde zakjes bevatten extra onderdelen.
 DE - Die Mengenangaben beziehen sich auf die für die Montage benötigten Teile. Es kann eine gewisse Überzahl an Teilen in der Packung vorhanden sein.

FR - Matériel nécessaire **GB** - Tools required **ES** - Material necesario
PT - Material necessário **IT** - Materiale necessario **NL** - Benodigdheden
DE - Erforderliche Werkzeuge

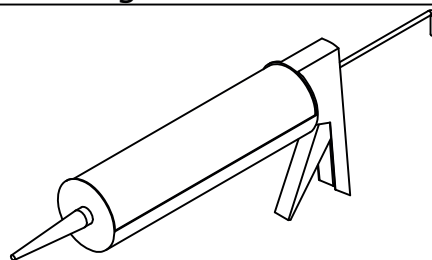
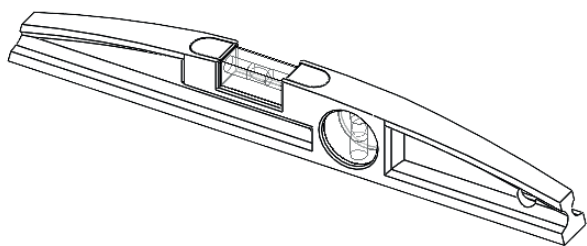

FR - Colle polyuréthane ou MS polymère
GB - Polyurethane adhesive or MS polymer
ES - Pegamento poliuretano o polímero MS
PT - Cola de poliuretano ou MS polímero
IT - Colla poliuretanoica o MS polimero
NL - Polyurethaan of MS-polymeer lijm
DE - Polyurethan oder MS-Polymere
 Montagekleber verwenden

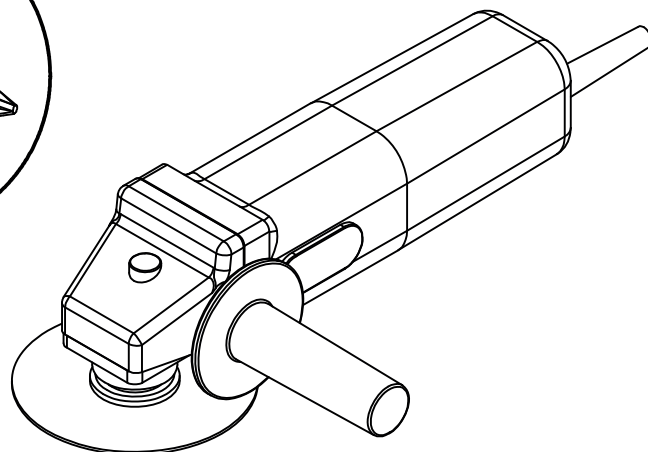
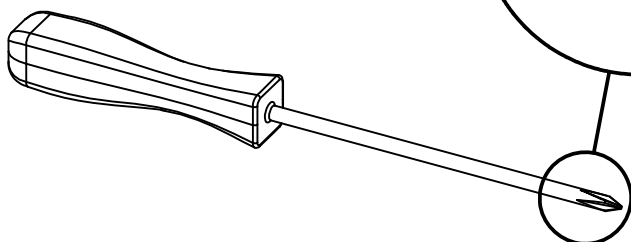
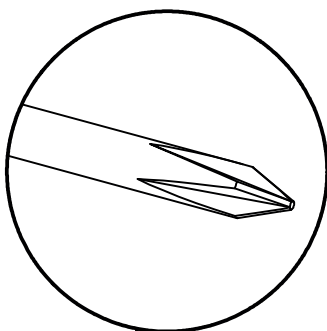
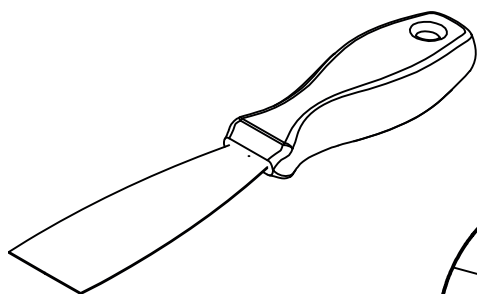

FR - Meuleuse avec lame diamant Ø230mm min.
GB - Grinder with diamond blade Ø230mm min.
ES - Pulidora con disco diamantado Ø230mm min.
PT - Rebarbadora com disco de diamante Ø230mm min.
IT - Mola con lama diamantata Ø230mm min.
NL - Diamantslijpschijf Ø230mm min.
DE - Winkelschleifer mit Diamanttrennscheibe Ø230mm min.

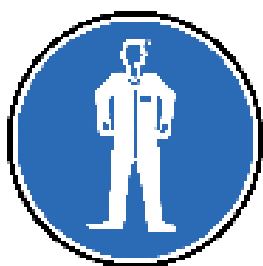

- FR** - DECOUPE OPTIONNELLE DU RECEVEUR
GB - ZONE AVAILABLE FOR OPTIONAL RECUTTING
ES - RECORTE OPCIONAL
PT - RECORTE OPCIONAL DA BASE
IT - TAGLIO OPZIONALE DEL PIATTO
NL - ZAGEN VAN DE DOUCHEBAK, OPTINEEL
DE - OPTIONALE SCHNEIDBEREICHE DER DUSCHWANNE

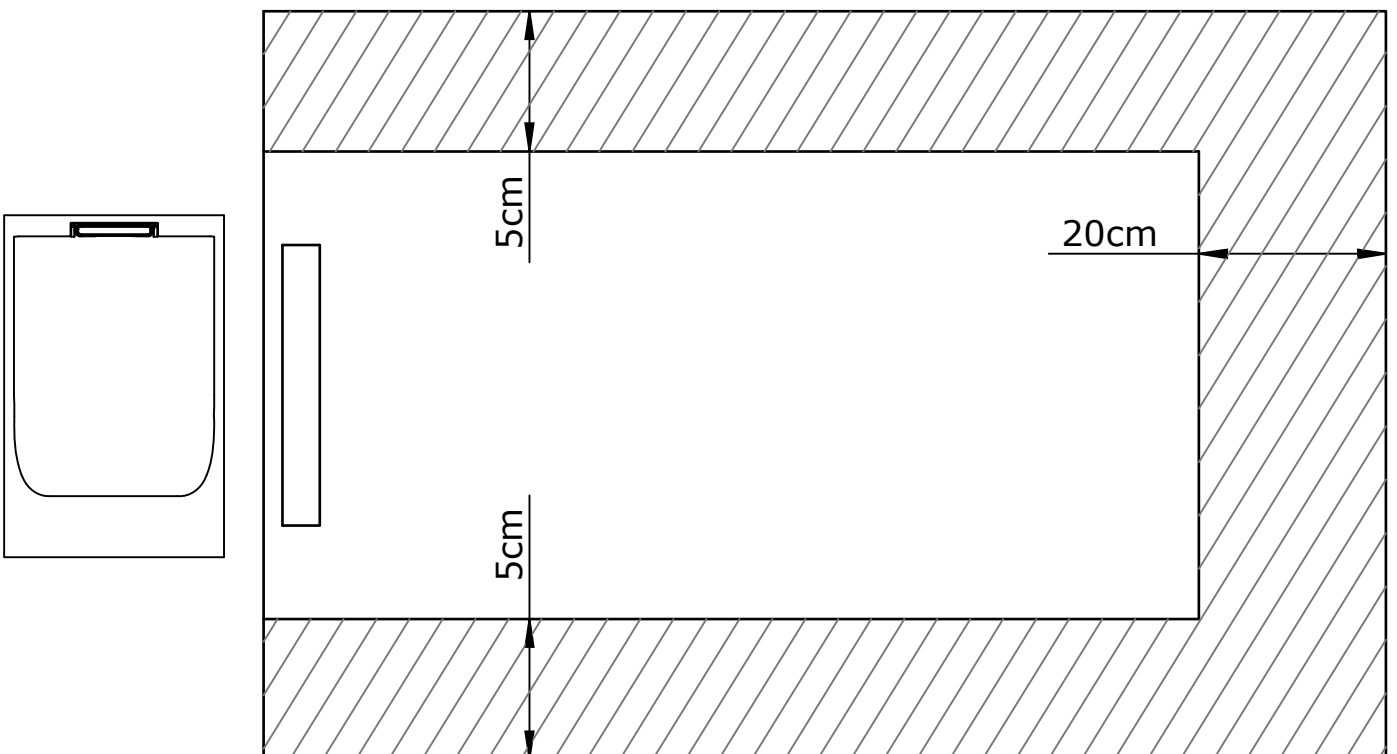
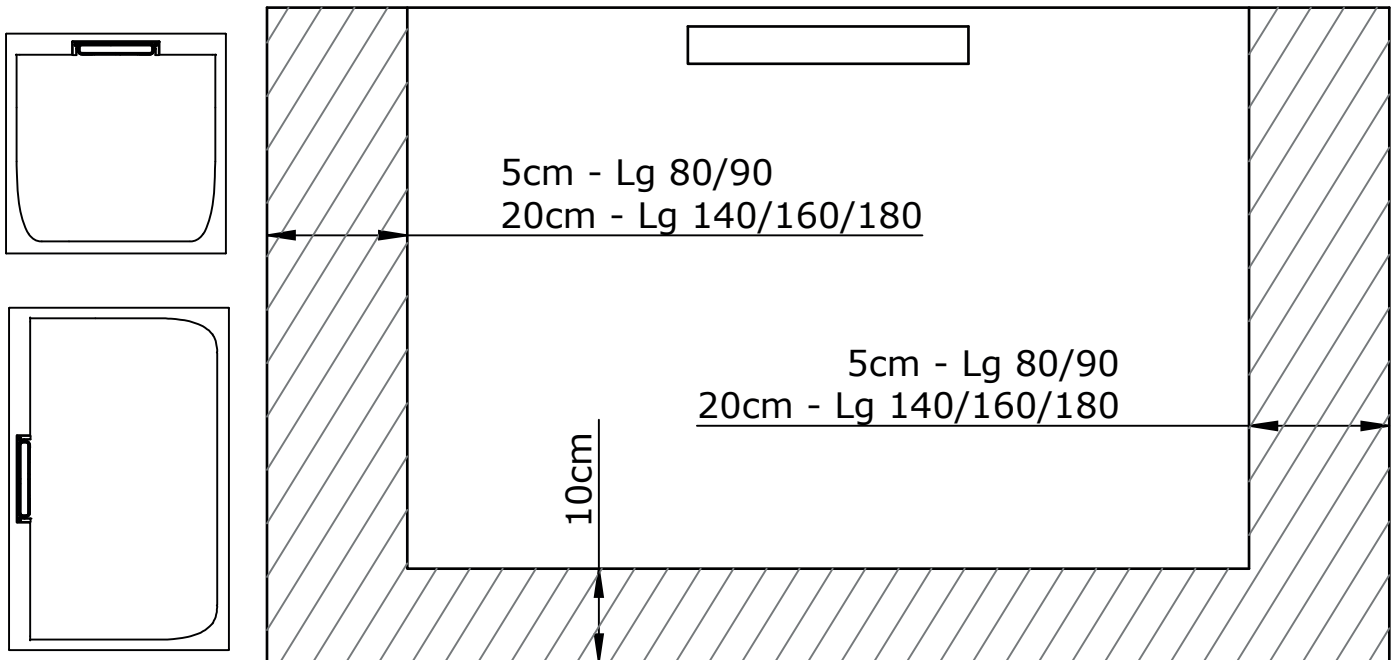

- FR** - Zone MAXI découpable
GB - MAX cuttable area
ES - Zona MAXIMA de recorte
PT - ÁREA MÁXIMA DE RECORTE
IT - Limite MASSIMO di taglio
NL - MAXIMAAL aanpasbaar deel
DE - MAXIMALER Schneidbereich

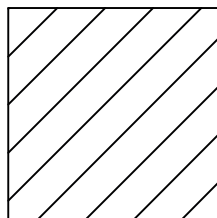

1

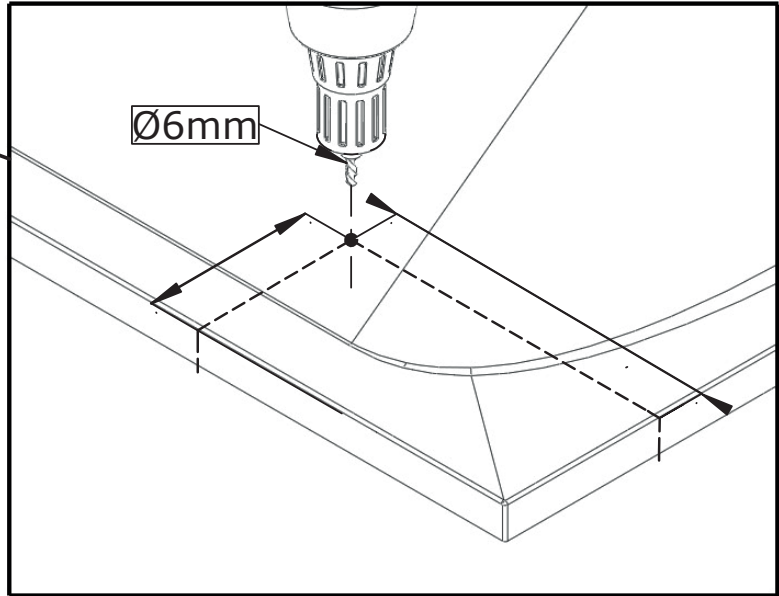
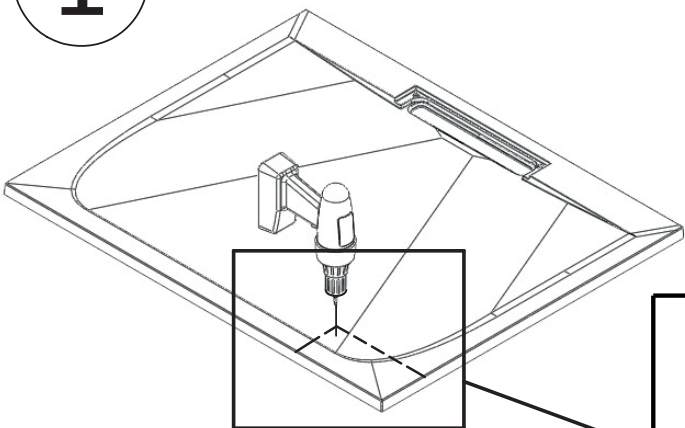

2

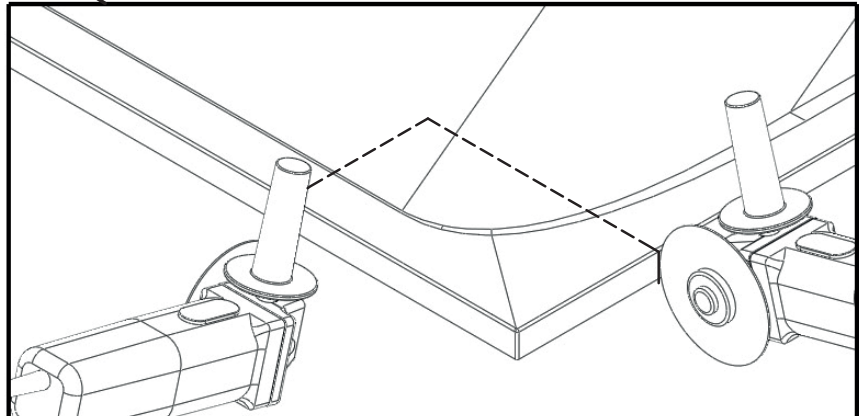
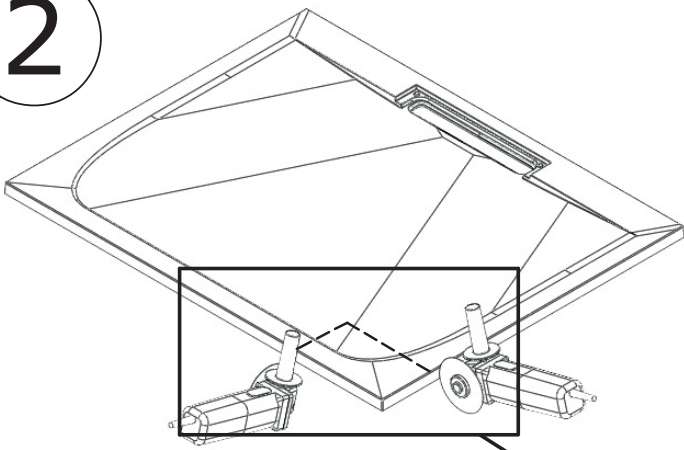

3



FR - Appliquer une couche de colle polyuréthane ou MS polymère à l'aide d'une spatule sur la surface coupée et combler l'espace entre les nervures du receveur avec une couche de mortier adhésif.

GB - Apply a polyurethane adhesive or MS polymer layer using a spatula over the raw surface and fill the space between the ribs of the tray with a layer of adhesive mortar.

ES - Aplicar una capa de pegamento poliuretano o polímero MS en la superficie recortada. Puede ayudarse de una espátula y rellenar los espacios huecos del plato con una capa de mortero adhesivo.

PT - Aplicar uma camada de cola de poliuretano ou MS polímero na superfície cortada com uma espátula e preencha o espaço vazio da base com uma camada de argamassa selante.

IT - Applicare della colla poliuretanicca o MS polimero con l'aiuto di una spatola sulla parte tagliato e compensare lo spazio tra le venature del piatto con uno strato di materiale adesivo.

NL - Breng met een spatel een laag polyurethaan lijm of MS polymeer lijm aan op de zaagranden, en vul de tussenliggende ruimte tot het steunoppervlak van de douchebak op met een laag cement.

DE - Wenn Sie ihre Duschtasse zuschneiden, müssen die Schnittkanten mittels Polyurethan- oder MS-Polymer-Klebstoff versiegelt werden. Tragen Sie die Versiegelung mit einem Spachtel auf der Schnittfläche bis unterhalb der Duschtasse auf.

FR - Colle polyuréthane/MS polymère

GB - Polyurethane adhesive/MS polymer

ES - Pegamento poliuretano/polimero MS

PT - Cola de poliuretano/MS polímero

IT - Colla poliuretanicca/MS polimero

NL - Polyurethaan/MS polymeer lijm

DE - Schicht aus Polyurethan-/
MS-Polymer-Klebstoff

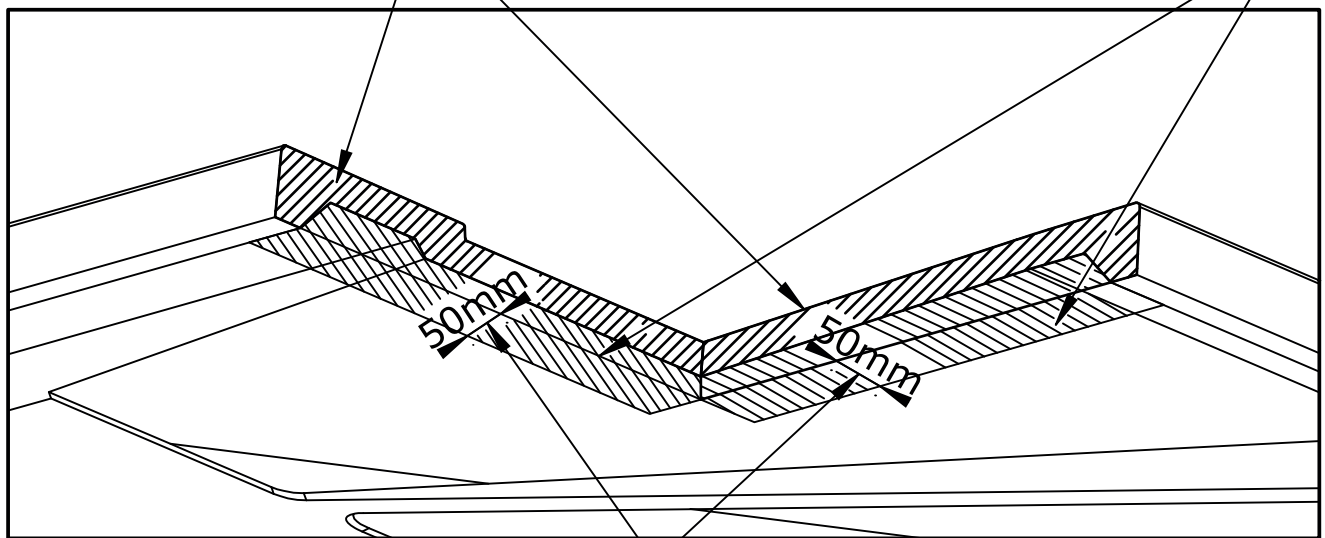
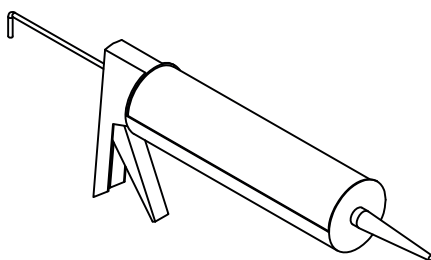

FR - Couche de 50mm de mortier adhésif. **GB** - 50mm layer of adhesive mortar.

ES - Capa de 50mm de grosor de mortero adhesivo.

PT - Camada de 50mm de argamassa selante.

IT - Strato di 50mm di materiale adesivo. **NL** - Laag van 50mm mortellijm.

DE - 50 mm x Schnittlänge mit Klebstoff auffüllen.

FR - Nombre de pieds. **GB** - Feet quantity. **ES** - Cantidad de pies
PT - Quantidade de pés. **IT** - Quantità di piedini. **NL** - Hoeveelheid voeten.
DE - Anzahl an Füße

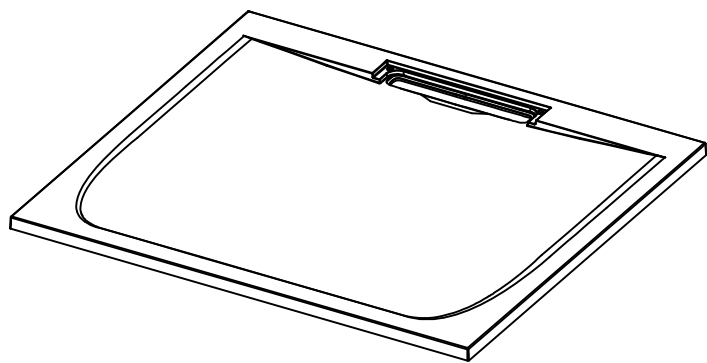

80x80	4	160x80	8
90x90	4	160x90	8
140x80	8	180x80	8
140x90	8	180x90	8

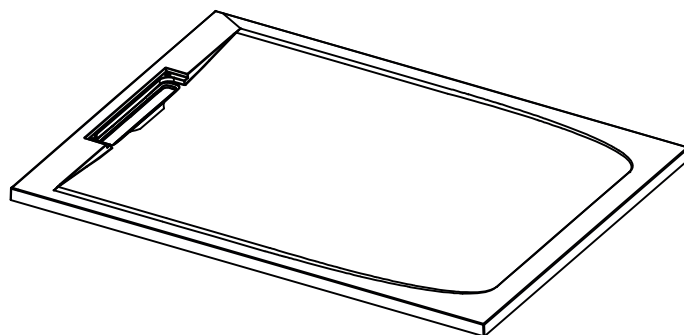

100x80	4	140x80	6	180x80	8
100x90	4	140x90	6	180x90	8
120x80	6	160x80	8		
120x90	6	160x90	8		

FR - La distance bord à bord entre deux pieds ne doit pas être de plus de 30 cm.
 LES PIEDS DOIVENT ETRE INSTALLES SUR LES NERVURES DU RECEVEUR.

GB - The distance from the edge of the shower tray to the edge of a peripheral support should be no more than 30 cm.
 THE FEET MUST BE INSTALLED ON THE SHOWER TRAY RIBS.

ES - La distancia entre cada pie no debe superar los 30 cm.
 LOS PIES DEBEN ESTAR INSTALADOS SIGUIENDO LAS NERVIOS DEL PLATO.

PT - A distância entre cada pé não deve exceder 30 cm.
 OS PÉS DEVEM SER INSTALADOS NAS NERVURAS DA BASE.

IT - La distanza tra due piedi non dovrebbe essere superiore a 30 cm.
 I PIEDI DEVONO ESSERE INSTALLATI SULLE NERVATURE DEL PIATTO DOCCIA.

NL - De afstand tussen twee stelpoten mag niet meer dan 30 cm bedragen.
 DE STELPOTEN DIENEN OP HET STEUNOPPERVLAK VAN DE DOUCHEBAK GEÏNSTALLEERD TE WORDEN.

DE - Der Abstand zwischen zwei verstellbaren Füßen darf 30 cm nicht überschreiten.
 DIE FÜßE MÜSSEN AUF DEN TRÄGERN DER DUSCHTASSE MONTIERT WERDEN.



30cm maxi

30cm maxi

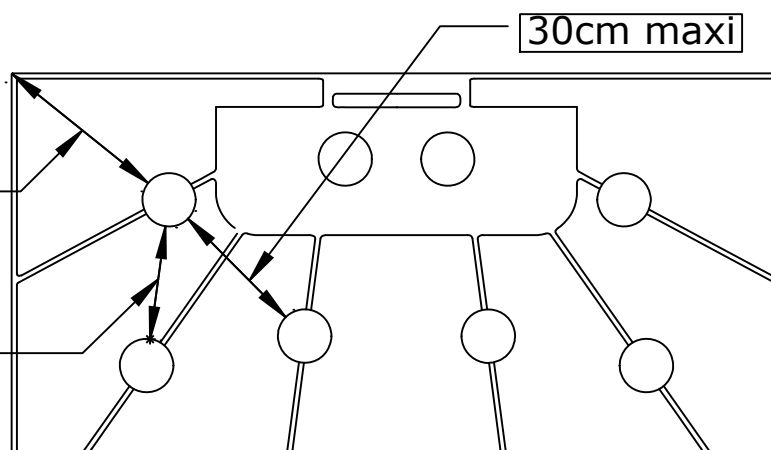

http://tiny.cc/notice_pieds_universelle

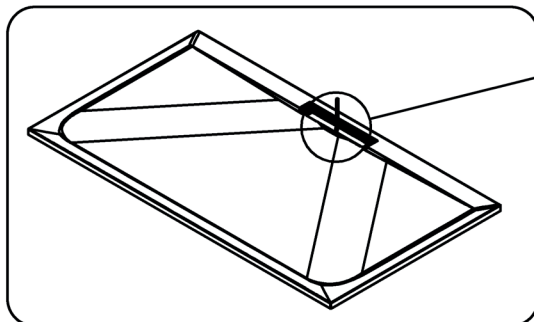
F

Tracer la position de la bonde et réaliser un montage à blanc de la bonde et du receveur

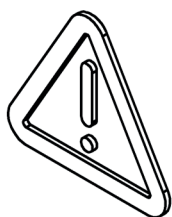
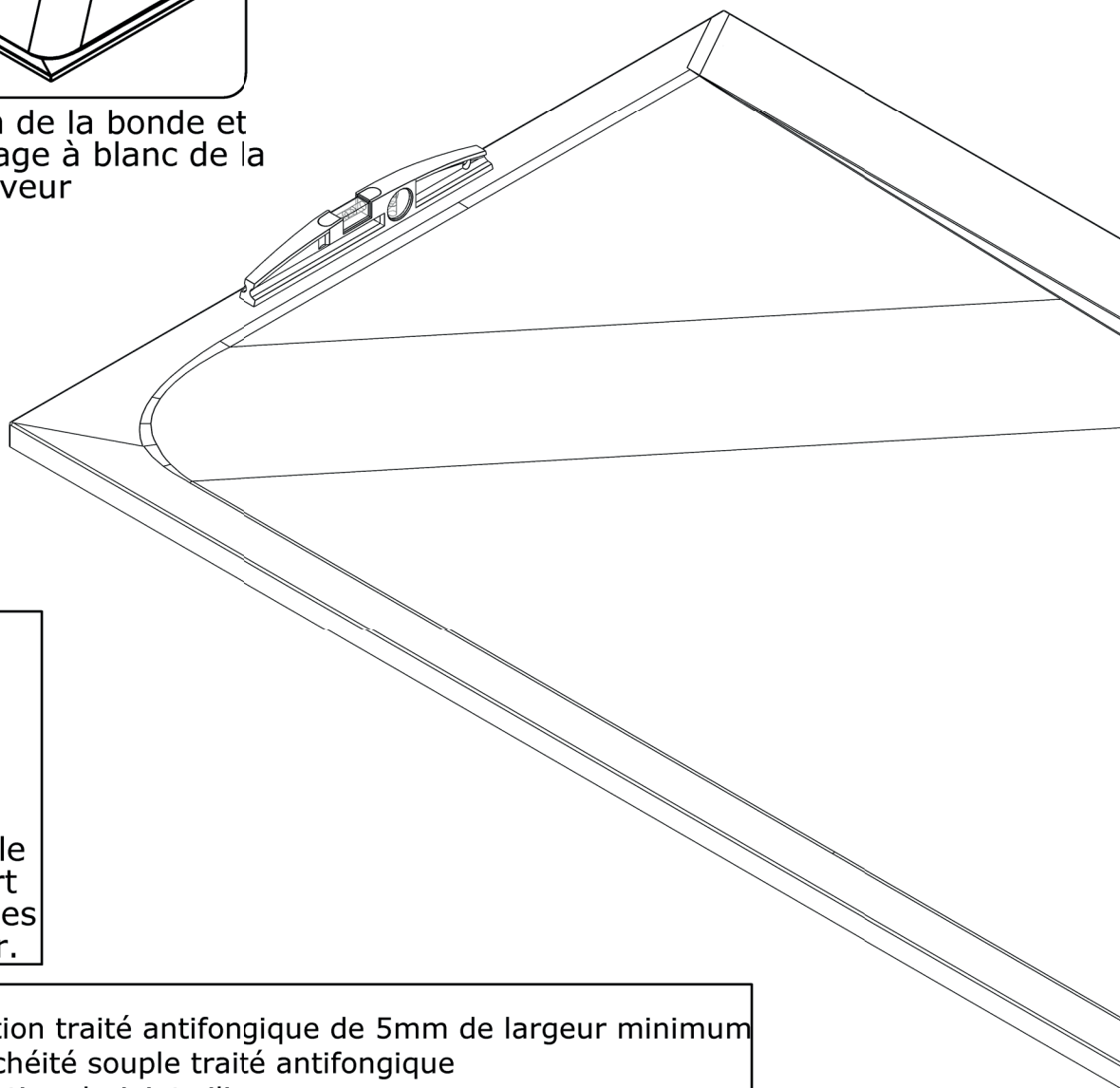

Il est indispensable d'avoir un support imputrescible sur les côtés du receveur.

- ① - silicone de finition traité antifongique de 5mm de largeur minimum
- ② - silicone d'étanchéité souple traité antifongique
- ③ - élément de soutien du joint silicone
- ④ - silicone d'appui
- ⑤ - colle polyuréthane ou MS polymère

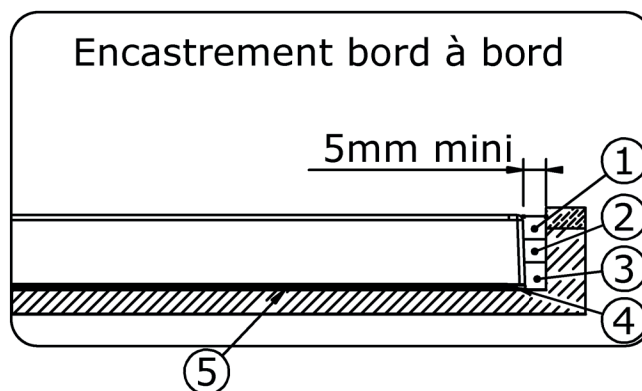
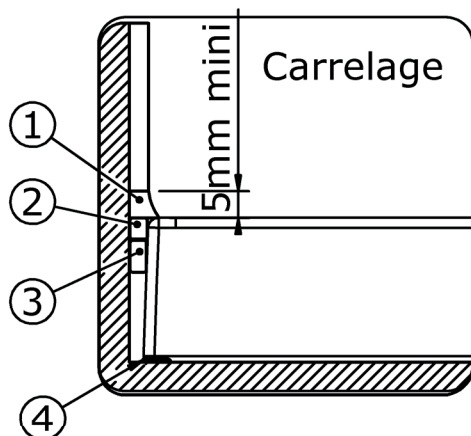



Pendant toute la durée des travaux, protéger le receveur contre toute agression : brûlures, chocs, rayures, décapants...



Le montage d'une soupape anti-vidé est nécessaire pour une utilisation optimale si un autre appareil sanitaire est raccordé sur la même évacuation.

Ne pas utiliser d'acide chlorhydrique ni de dégraissant puissant

Pose directe au sol

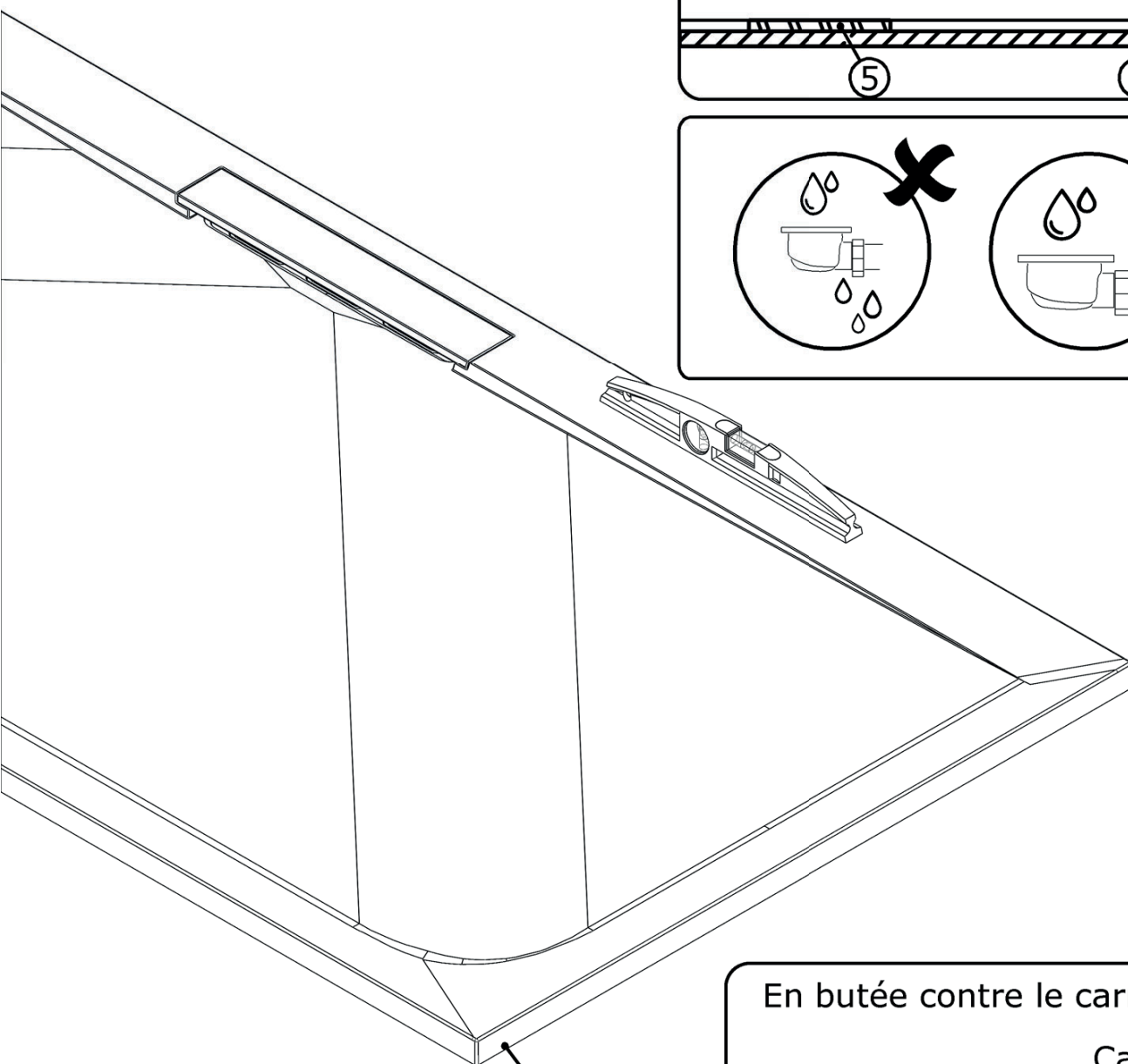
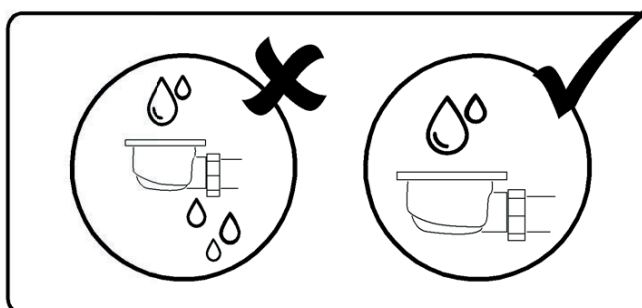
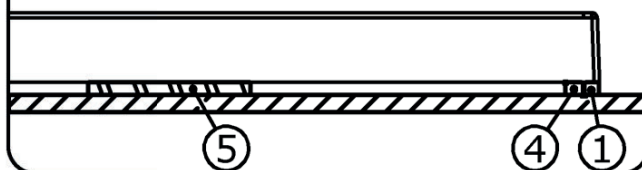

Sol rigide, plan et non humide indispensable

En butée contre le carrelage

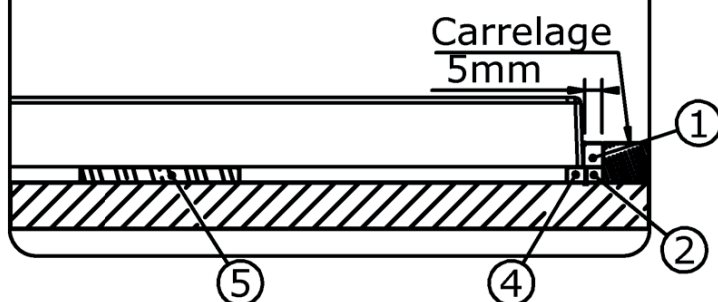

TYPES D'INSTALLATION

KINELINE CARRÉ, RECTANGULAIRE BONDE CENTRÉE SUR LA LONGUEUR

1. Posé sur pieds réglables avec habillage carrelé

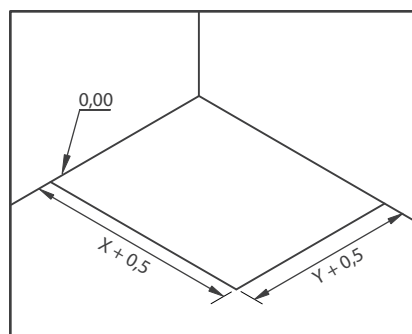
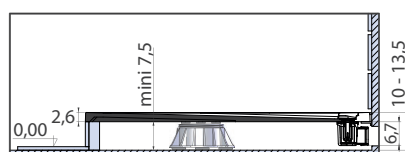

Préparation de l'implantation

X	Y	C	D
80	80	68	21,5
90	90	78	26,5
140	80	68	51,5
140	90	78	51,5
160	80	68	61,5
160	90	78	61,5
180	80	68	71,5
180	90	78	71,5

2. Posé en butée contre le carrelage

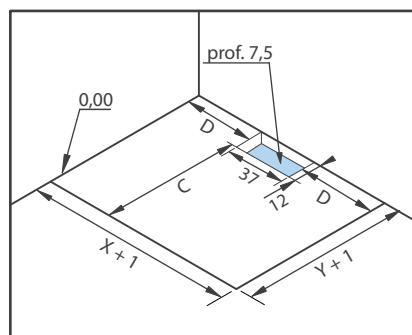
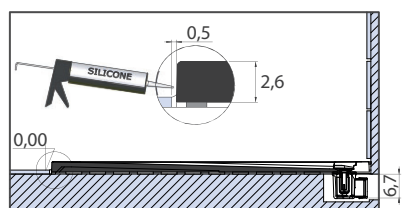
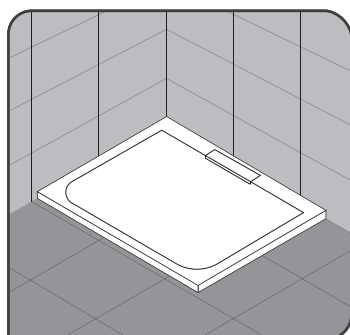

Préparation de l'implantation

3. Encasté et posé sur pieds réglables

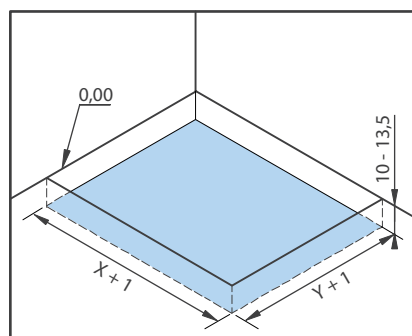
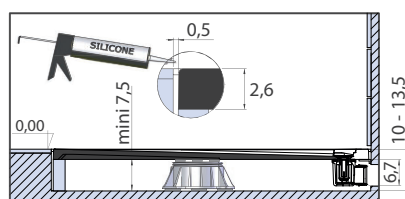

Préparation de l'implantation

4. Encasté et posé sans pieds réglables

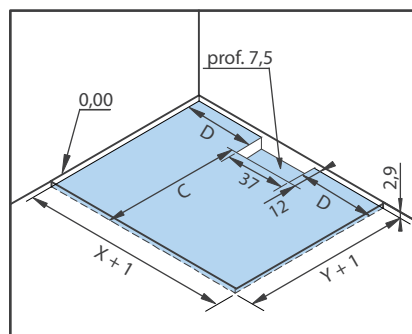
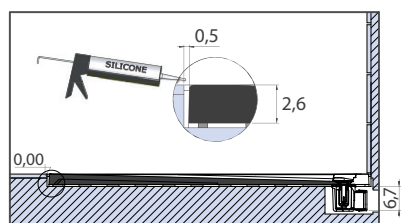
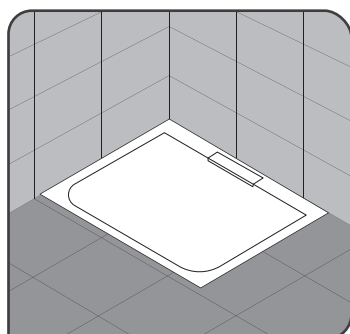

Préparation de l'implantation

TYPES D'INSTALLATION

KINELINE RECTANGULAIRE BONDE CENTRÉE SUR LA LARGEUR

1. Posé sur pieds réglables avec habillage carrelé

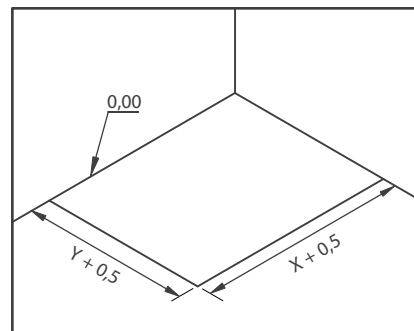
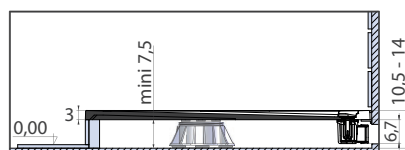

X	Y	C	D
100	80	88	21,5
100	90	88	26,5
120	80	108	21,5
120	90	108	26,5
140	80	128	21,5
140	90	128	26,5
160	80	148	21,5
160	90	148	26,5
180	80	168	21,5
180	90	168	26,5

Préparation de l'implantation

2. Posé en butée contre le carrelage

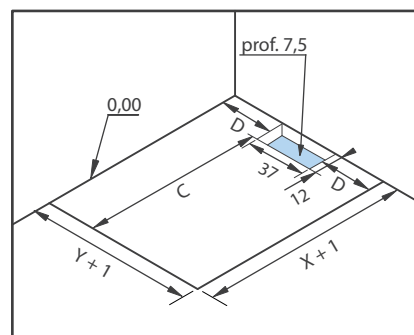
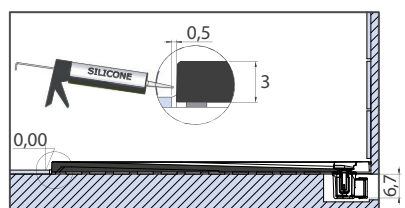
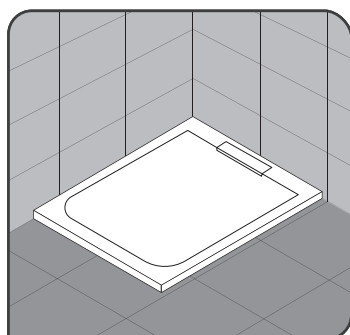

Préparation de l'implantation

3. Encastré et posé sur pieds réglables

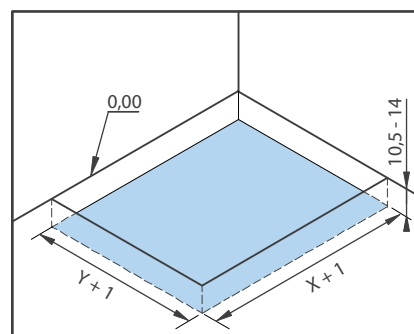
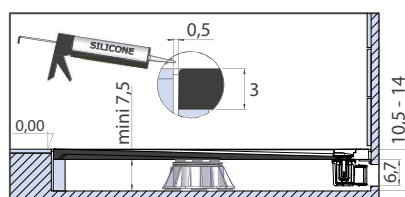

Préparation de l'implantation

4. Encastré et posé sans pieds réglables

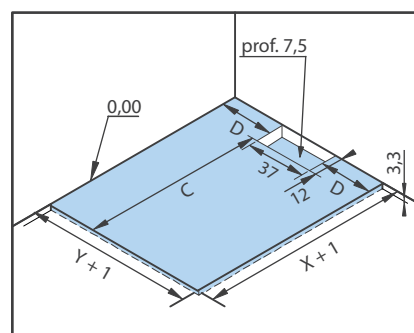
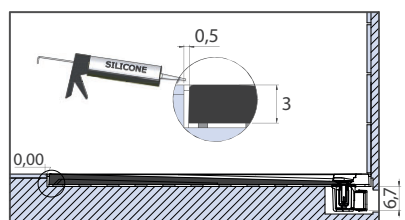
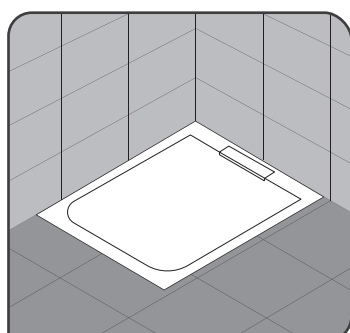

Préparation de l'implantation

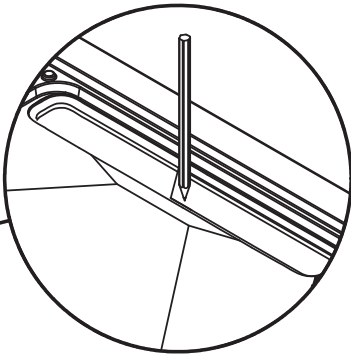
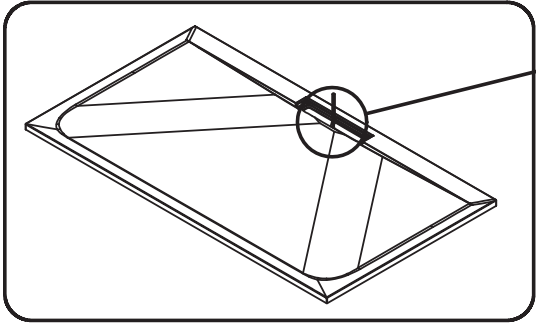

Mark the position of the waste and test-assemble the tray and waste

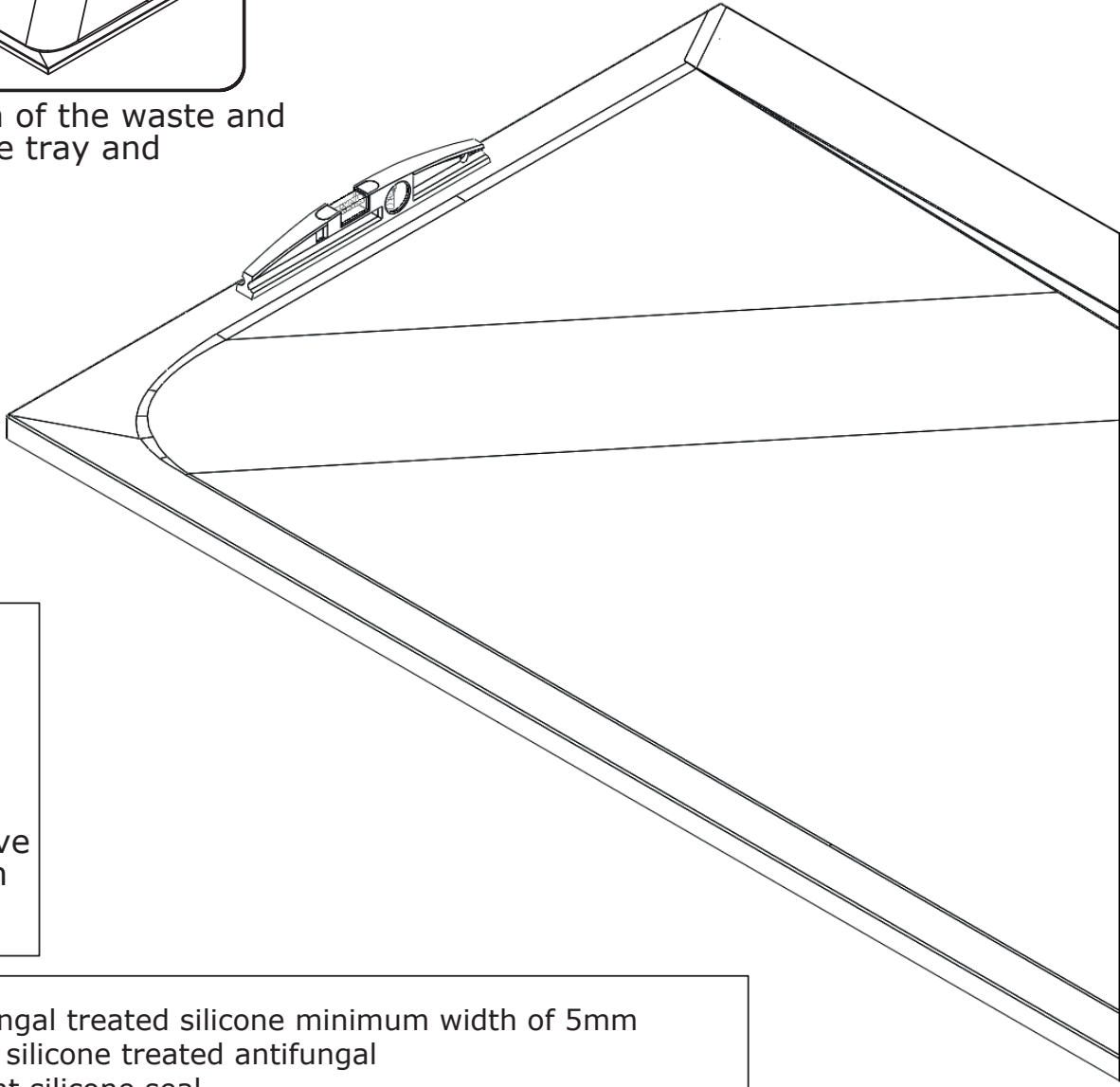

- ① - finishing antifungal treated silicone minimum width of 5mm
- ② - flexible sealing silicone treated antifungal
- ③ - support Element silicone seal
- ④ - silicone support
- ⑤ - polyurethane adhesive or MS polymer

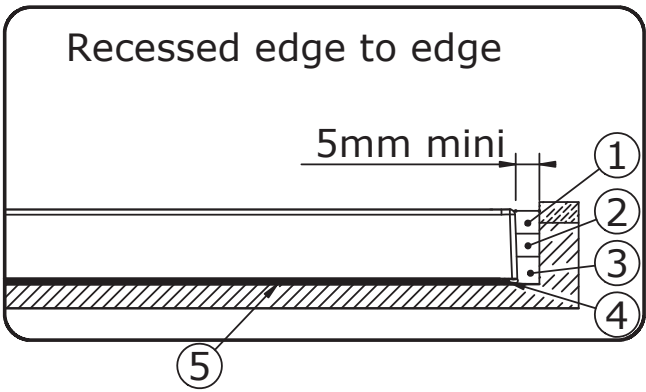
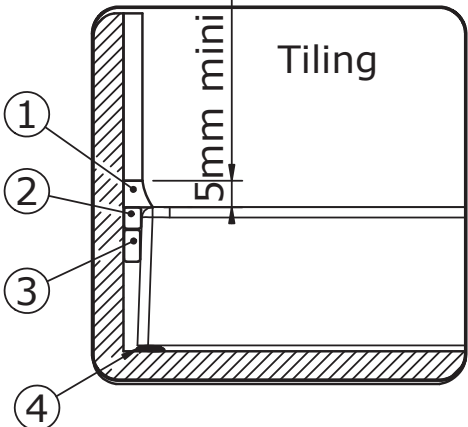

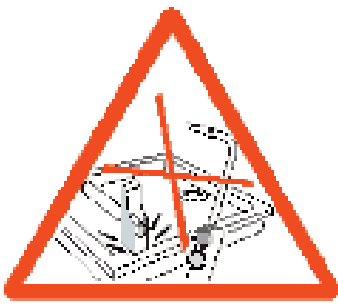

Throughout the duration of the installation, protect the recipient against any scratches, burns, shocks etc



The installation of an anti-vacuum valve is necessary for optimal use if another appliance is connected to the same discharge pipe

Do not use hydrochloric acid or powerful degreaser

Direct floor installation

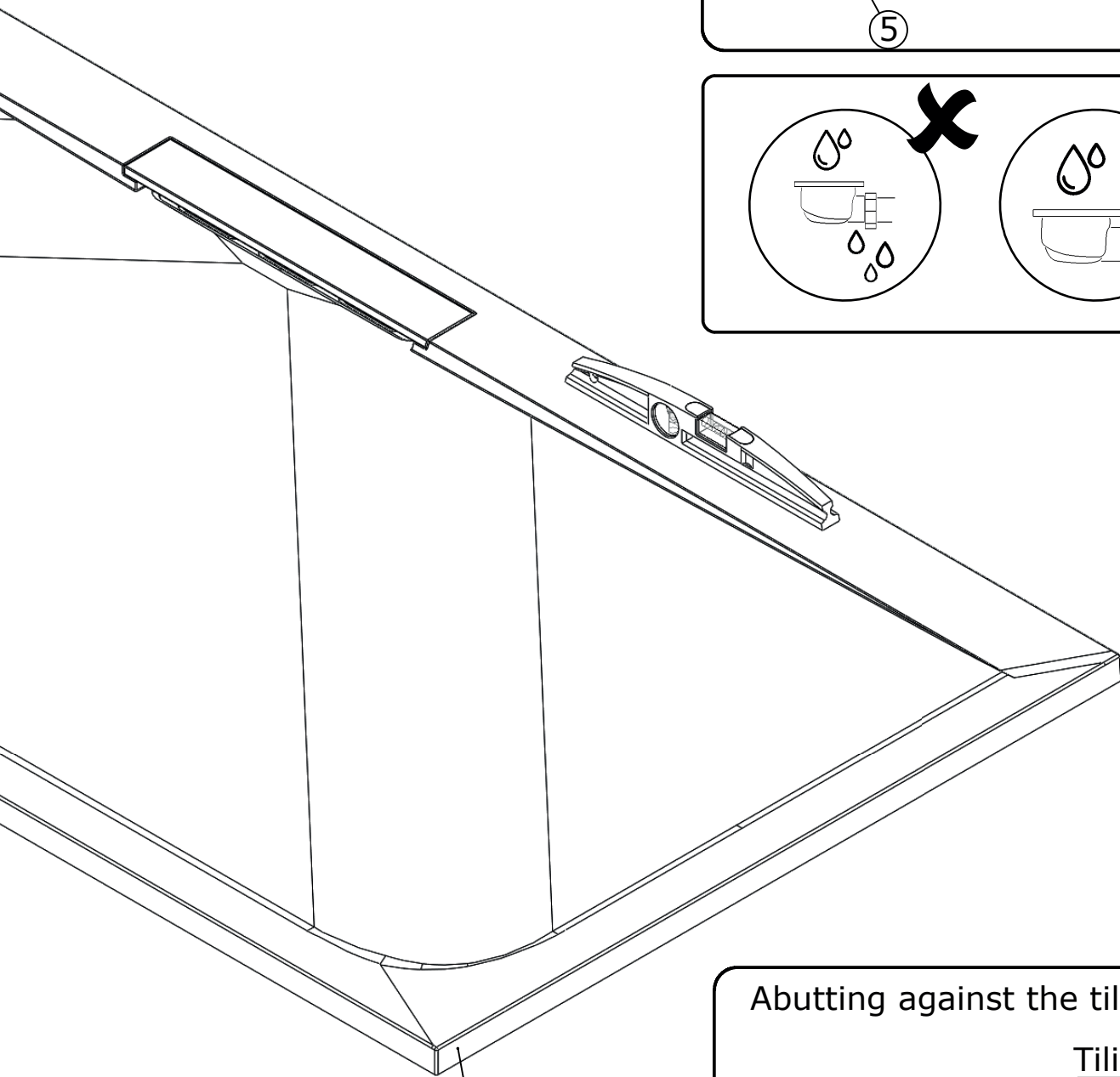
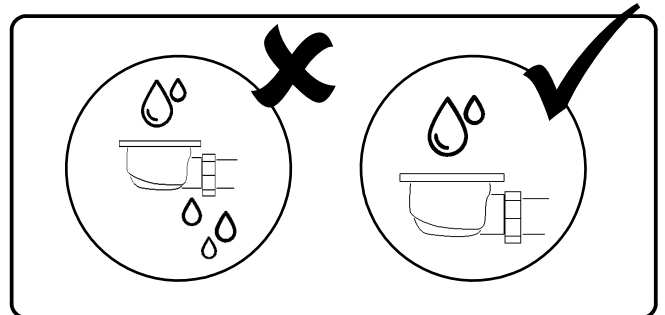
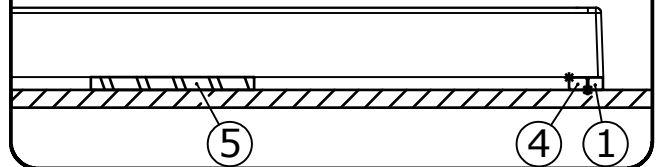

The base must be rigid, flat and dry

Abutting against the tile

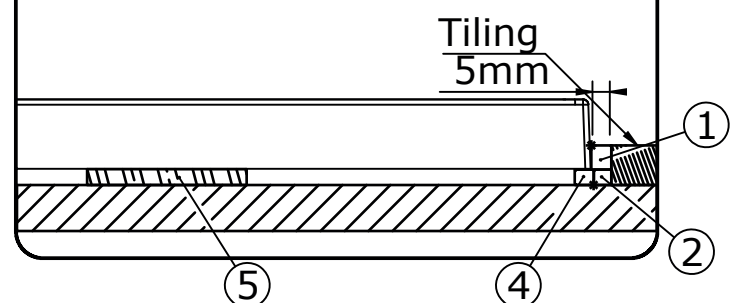

INSTALLATION TYPES

KINELINE SQUARE, RECTANGULAR DRAIN CENTERED ON THE LENGTH

1. Mounted on adjustable legs with cladding

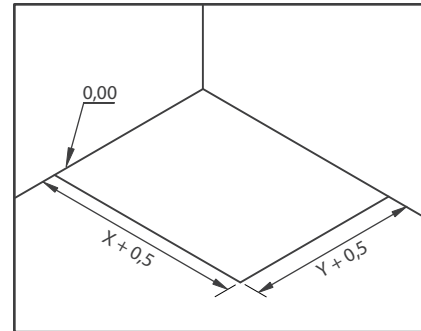
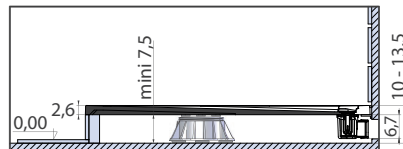

X	Y	C	D
80	80	68	21,5
90	90	78	26,5
140	80	68	51,5
140	90	78	51,5
160	80	68	61,5
160	90	78	61,5
180	80	68	71,5
180	90	78	71,5

Pre-installation

2. Installed in abutment against the tile

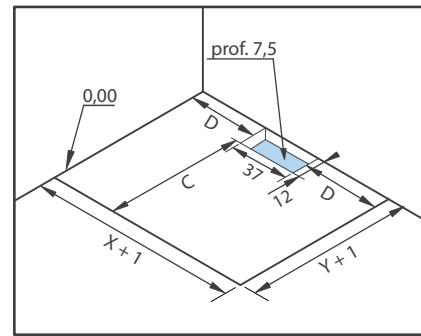
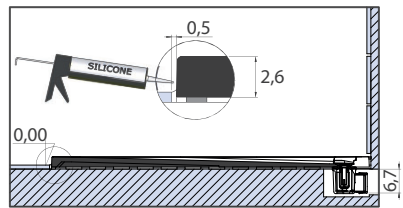
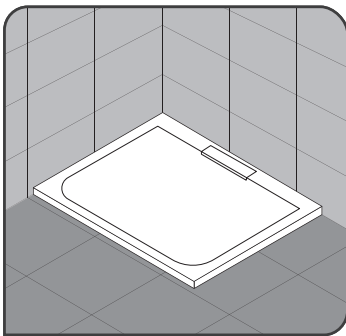

Pre-installation

3. Built-in and placed on adjustable legs

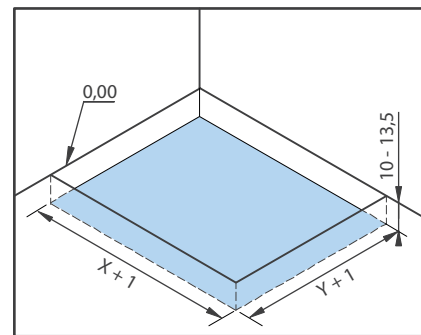
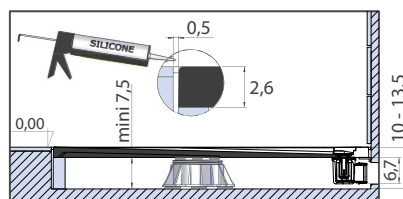

Pre-installation

4. Built-in and installed without adjustable feet

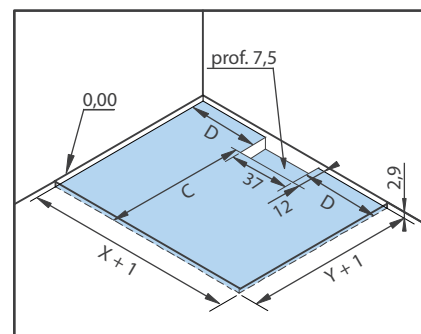
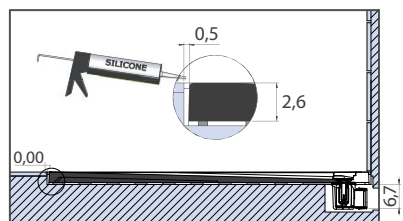
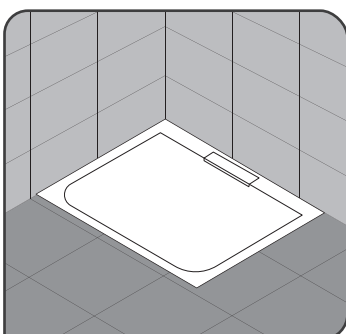

Pre-installation

INSTALLATION TYPES

KINELINE RECTANGULAR DRAIN CENTERED ON THE WIDTH

1. Mounted on adjustable legs with cladding

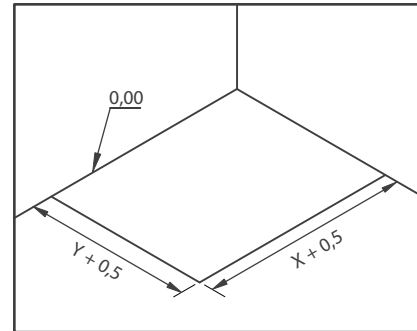
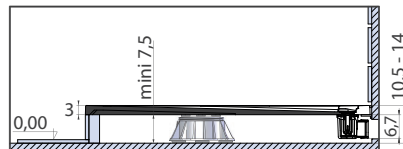

X	Y	C	D
100	80	88	21,5
100	90	88	26,5
120	80	108	21,5
120	90	108	26,5
140	80	128	21,5
140	90	128	26,5
160	80	148	21,5
160	90	148	26,5
180	80	168	21,5
180	90	168	26,5

Pre-installation

2. Installed in abutment against the tile

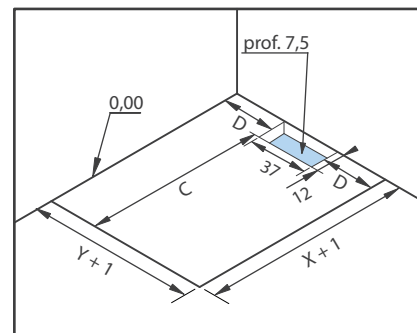
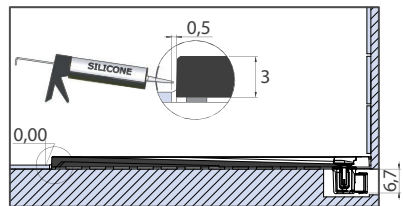
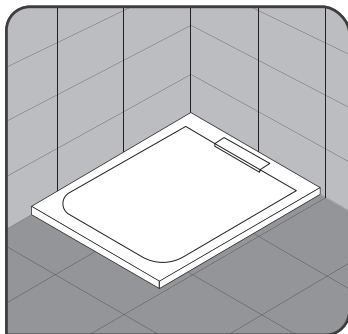

Pre-installation

3. Built-in and placed on adjustable legs

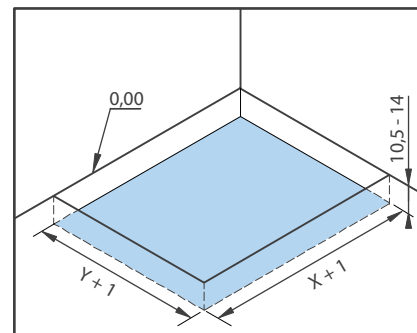
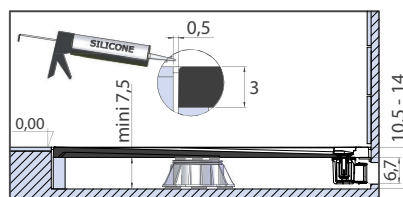
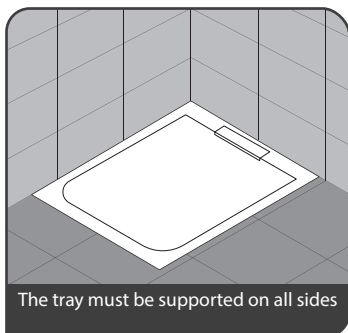

Pre-installation

4. Built-in and installed without adjustable feet

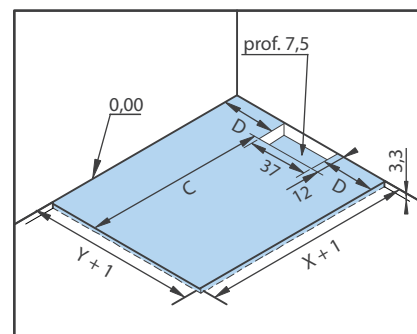
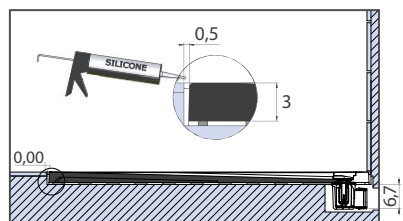
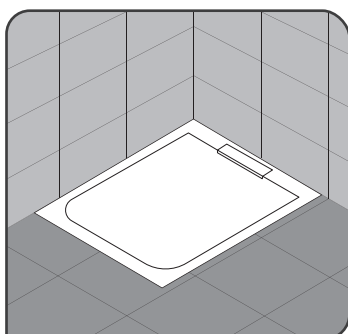

Pre-installation

E

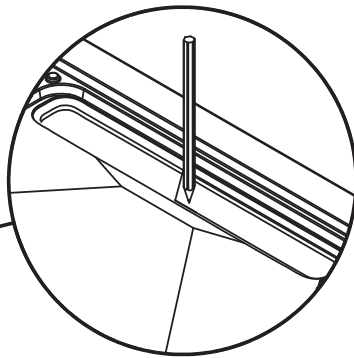
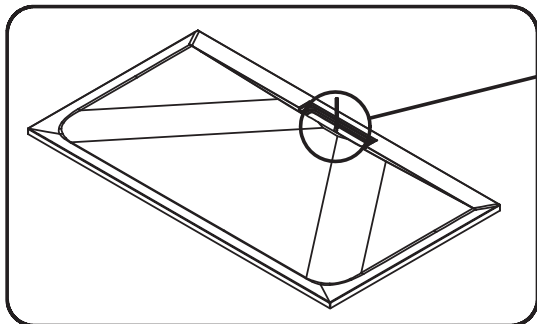

Marcar la ubicación del desagüe y montar el plato para comprobar su correcta ubicación.

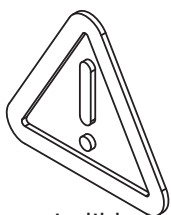
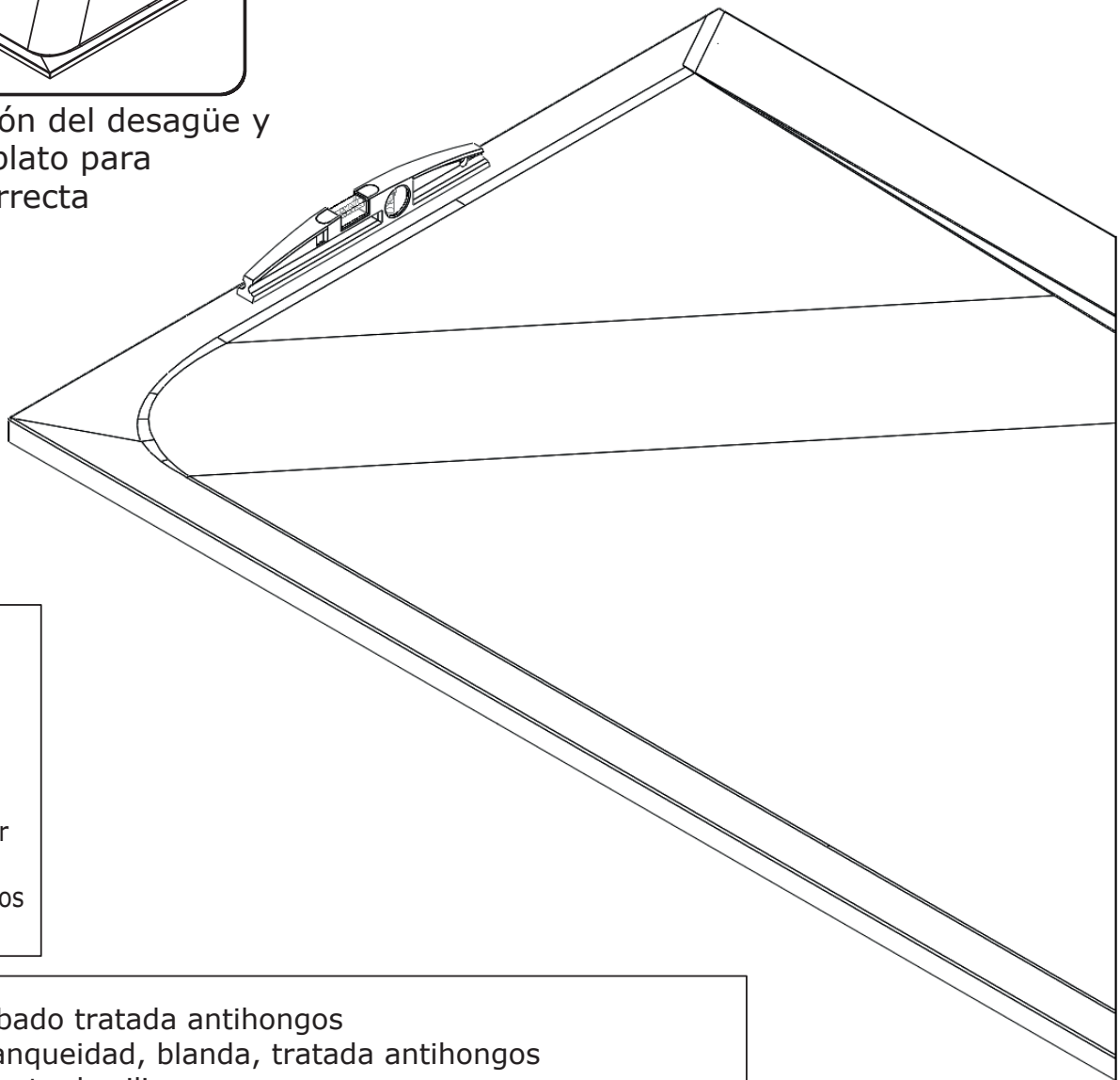

Es imprescindible instalar el plato en una zona que sea imputrescible en todos sus lados

- ① - silicona de acabado tratada antihongos
- ② - silicona de estanqueidad, blanda, tratada antihongos
- ③ - soporte de la junta de silicona
- ④ - silicona de apoyo
- ⑤ - pegamento poliuretano o polímero MS

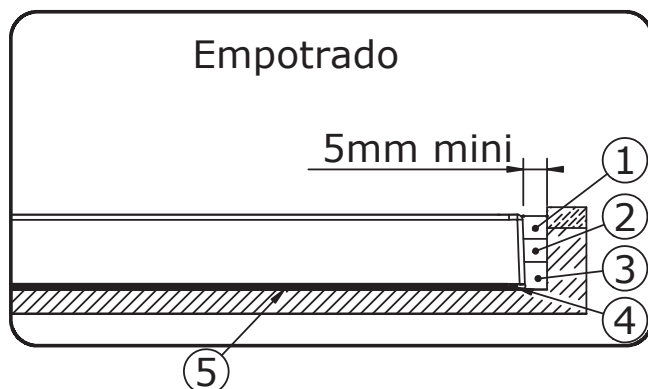
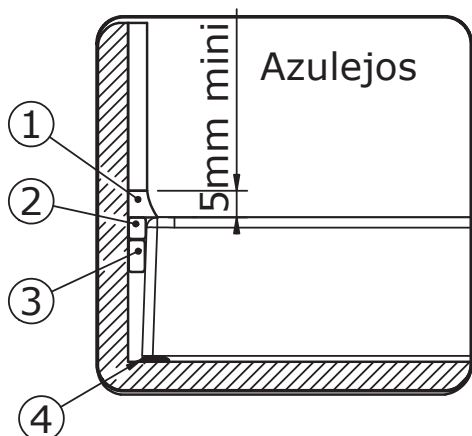



Durante las obras proteger el plato de golpes, quemaduras, rayaduras, etc...



Durante las obras proteger el plato de golpes, quemaduras, rayaduras, etc...

No utilizar ácido clorhídrico o desengrasante potente

Instalación directa al suelo

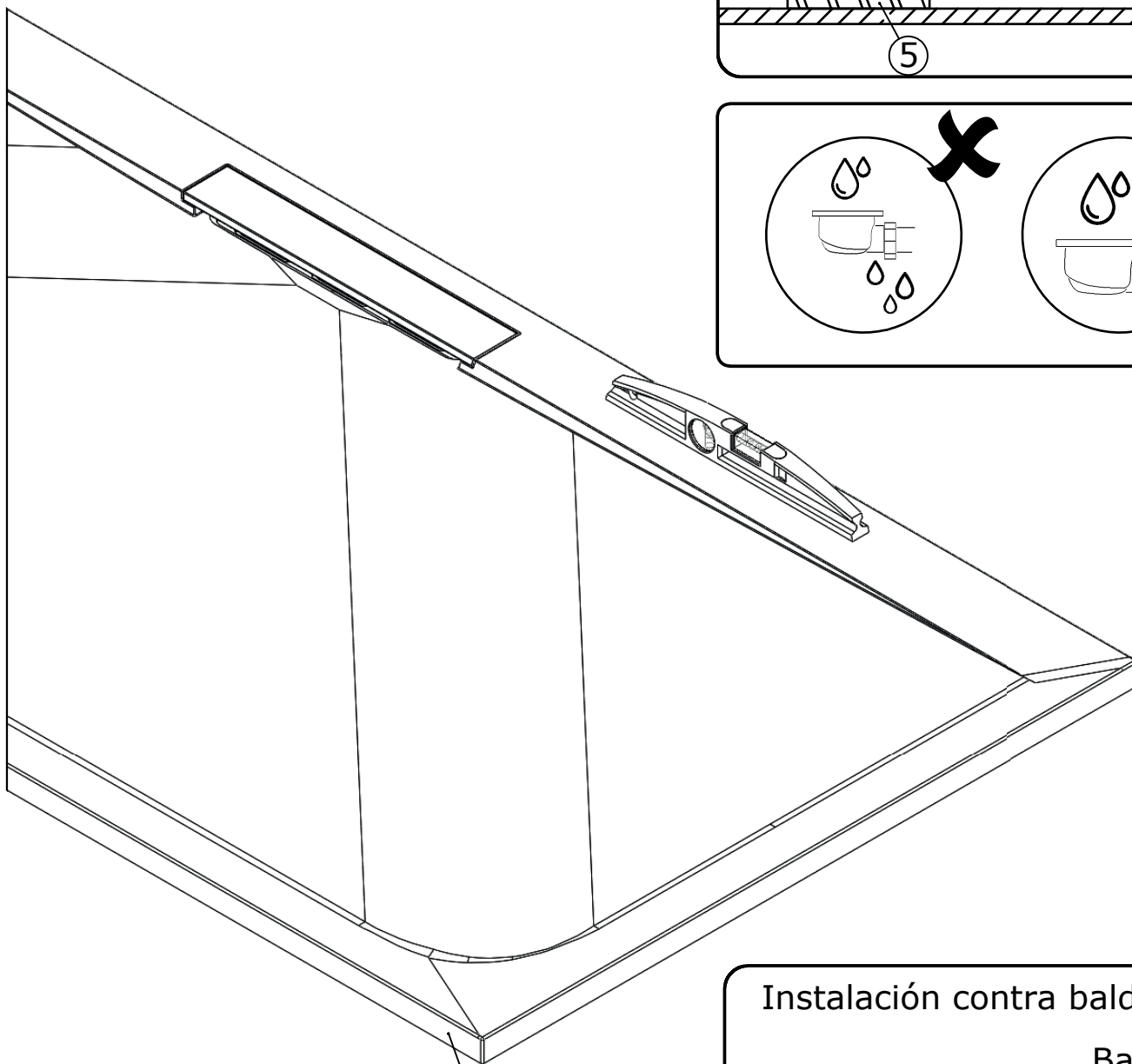
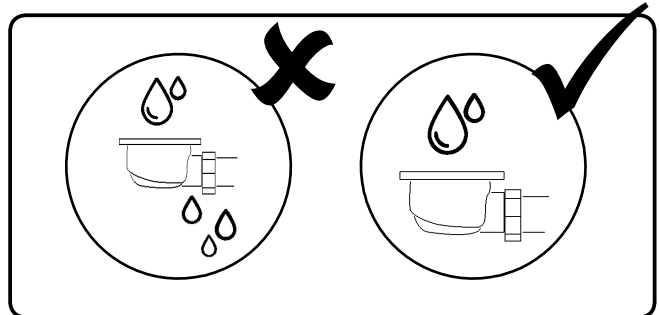
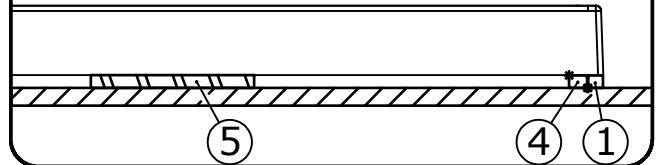

Instalación contra baldosas

Baldosas
5mm

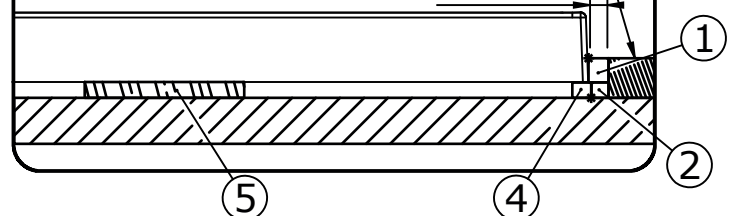

Suelo rígido, plano y seco indispensable

TIPOS DE INSTALACIÓN

KINELINE CUADRADO, RECTANGULAR DRENAJE CENTRADO EN LONGITUD

1. Instalado sobre pies ajustables con revestimiento de baldosas

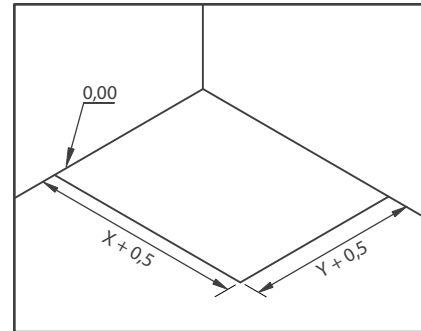
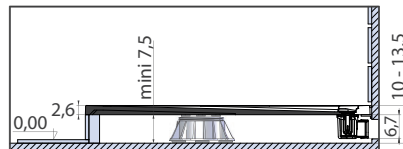

X	Y	C	D
80	80	68	21,5
90	90	78	26,5
140	80	68	51,5
140	90	78	51,5
160	80	68	61,5
160	90	78	61,5
180	80	68	71,5
180	90	78	71,5

Preparación de la instalación

2. Colocación sobre suelo

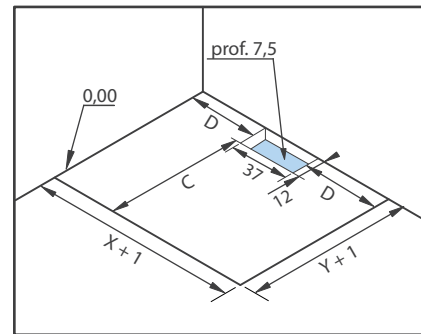
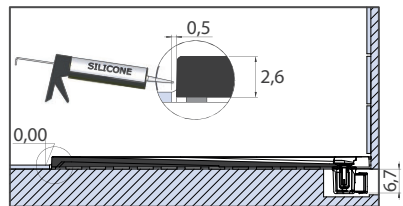
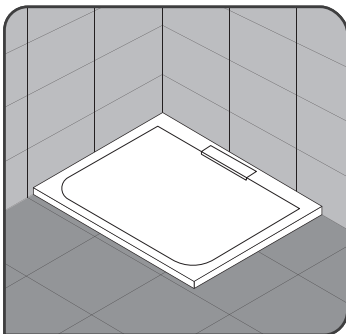

Preparación de la instalación

3. Instalación a ras de suelo, colocado sobre pies ajustables

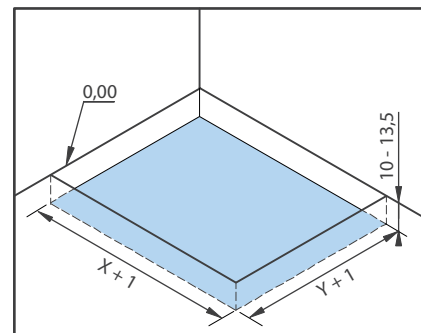
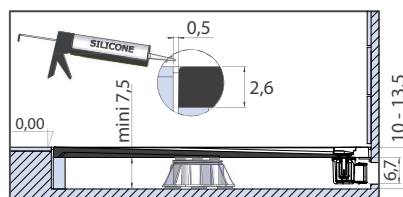

Preparación de la instalación

4. Instalación a ras de suelo, sin pies ajustables

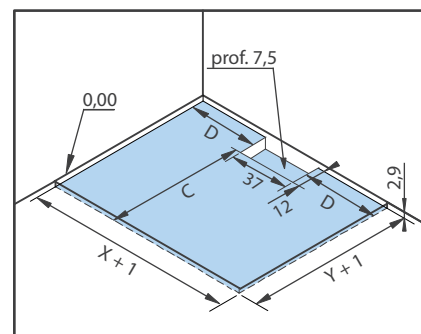
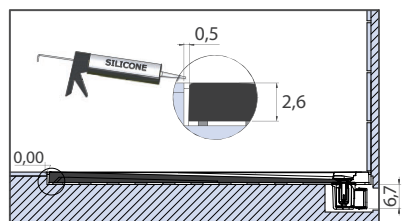
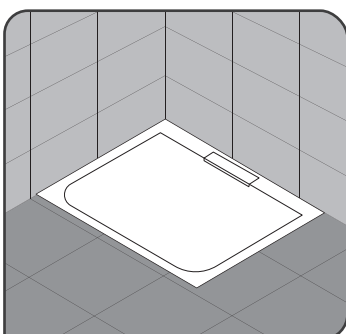

Preparación de la instalación

TIPOS DE INSTALACIÓN

KINELINE RECTANGULAR DRENAJE CENTRADO EN ANCHO

1. Instalado sobre pies ajustables con revestimiento de baldosas

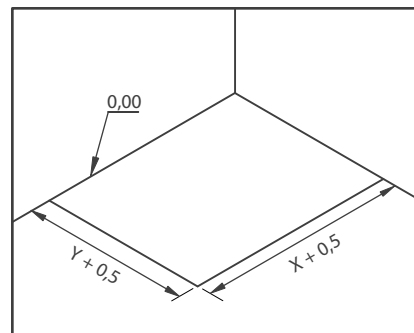
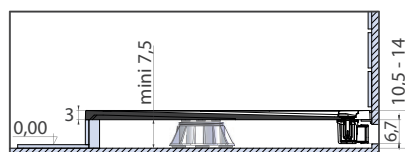

X	Y	C	D
100	80	88	21,5
100	90	88	26,5
120	80	108	21,5
120	90	108	26,5
140	80	128	21,5
140	90	128	26,5
160	80	148	21,5
160	90	148	26,5
180	80	168	21,5
180	90	168	26,5

Preparación de la instalación

2. Colocación sobre suelo

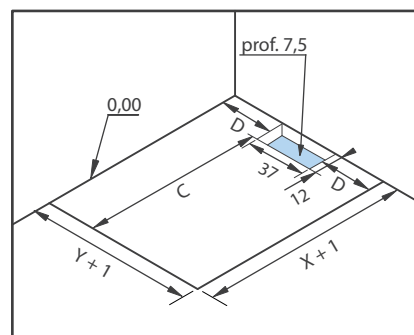
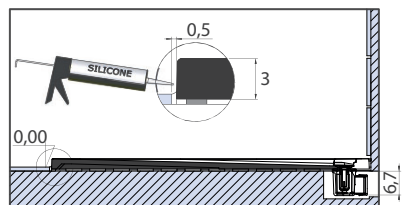
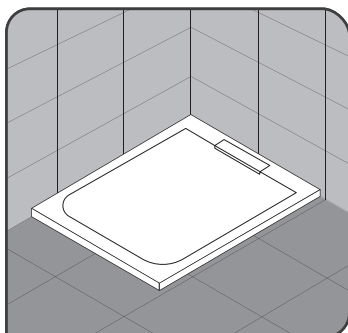

Preparación de la instalación

3. Instalación a ras de suelo, colocado sobre pies ajustables

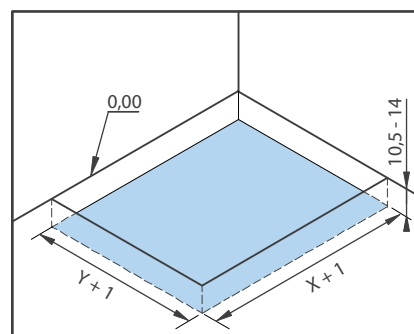
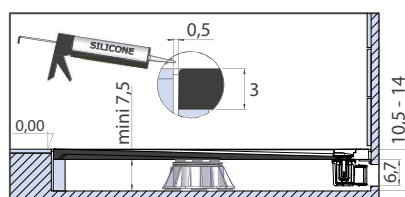

Preparación de la instalación

4. Instalación a ras de suelo, sin pies ajustables

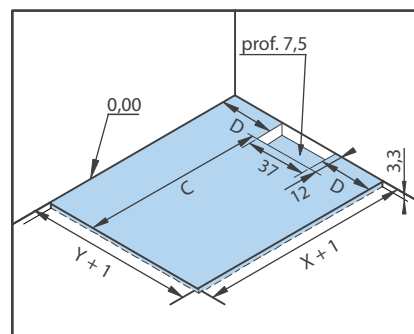
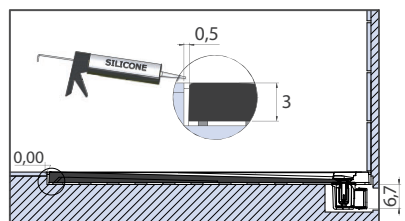
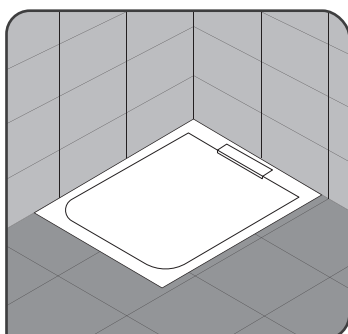

Preparación de la instalación

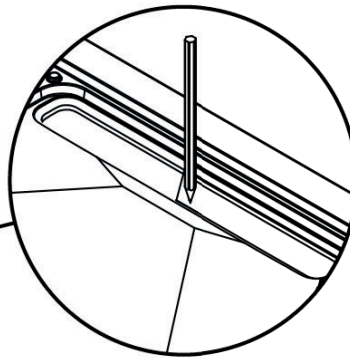
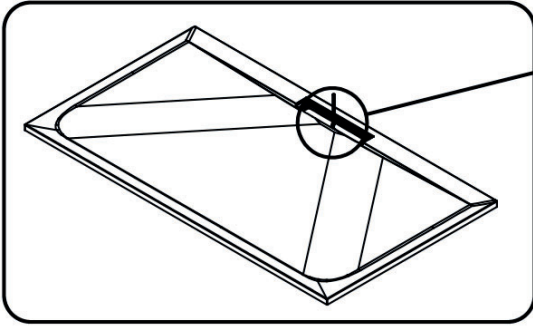

Marcar a localização da válvula e colocar a válvula na base para verificar se a localização é a correta.

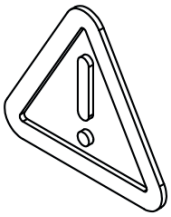
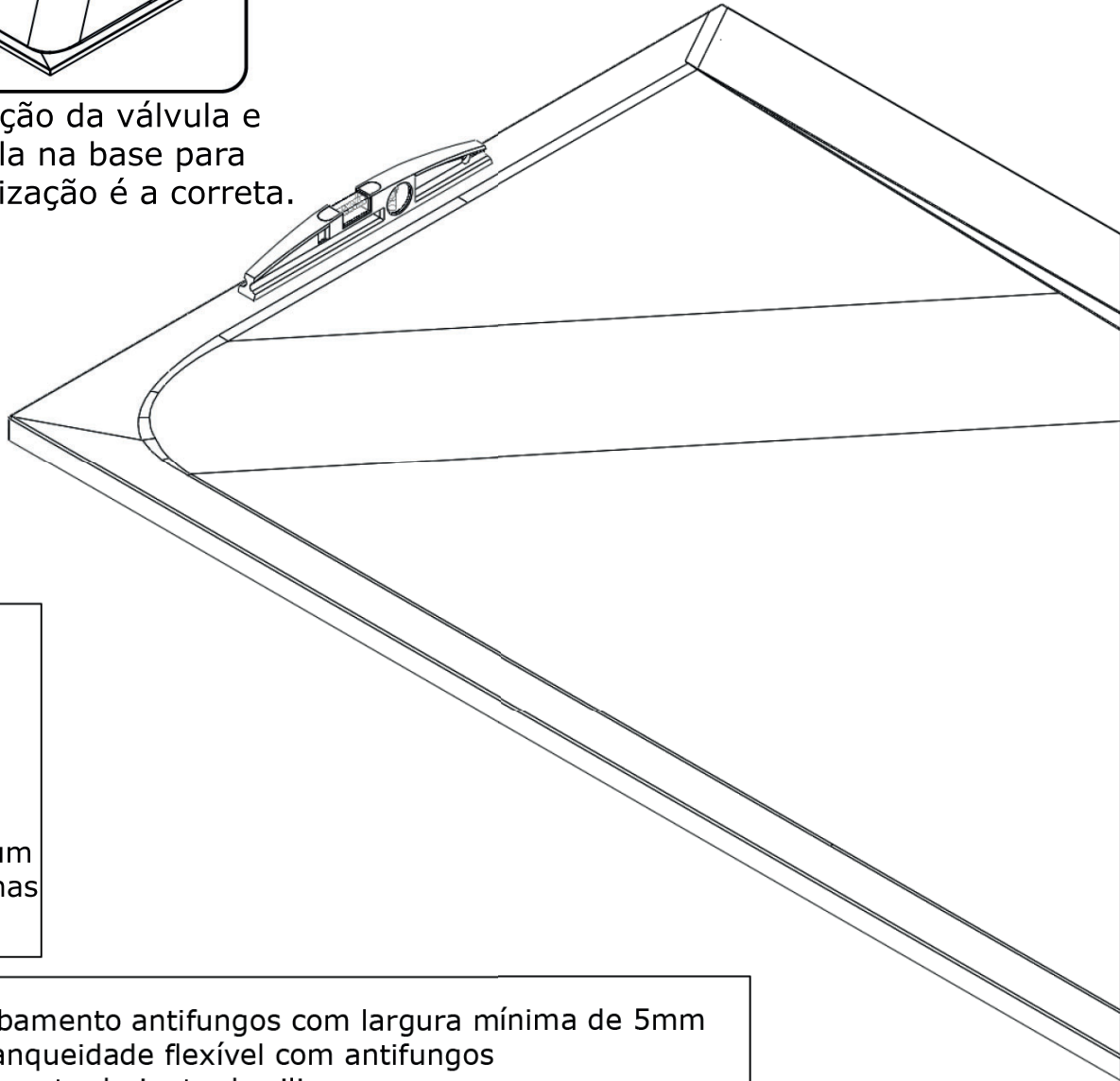

É indispensável ter um apoio imputrescível nas laterais da base.

- ① - silicone de acabamento antifungos com largura mínima de 5mm
- ② - silicone de estanqueidade flexível com antifungos
- ③ - elemento de suporte da junta de silicone
- ④ - silicone de apoio
- ⑤ - cola poliuretano ou MS polímero

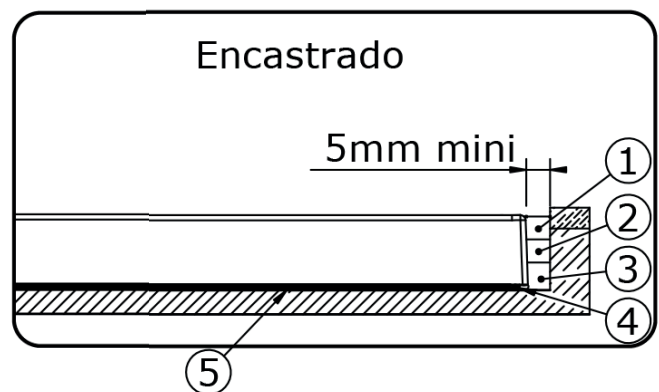
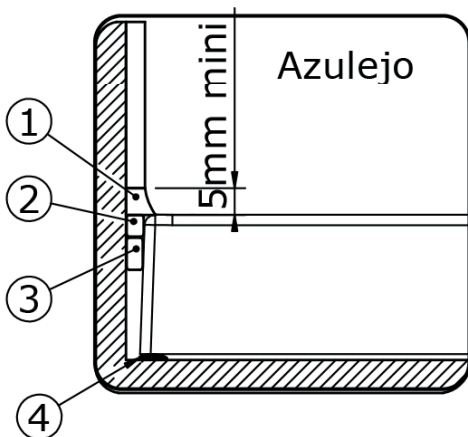



Durante toda a duração da obra, proteger a base de qualquer dano: queimadura, impacto, risco, etc...



Instalar uma válvula anti-vácuo para um bom funcionamento, caso outro elemento sanitário esteja ligado à mesma evacuação.

Não utilizar ácido clorídrico ou desengordurantes agressivos

Instalação direta no solo

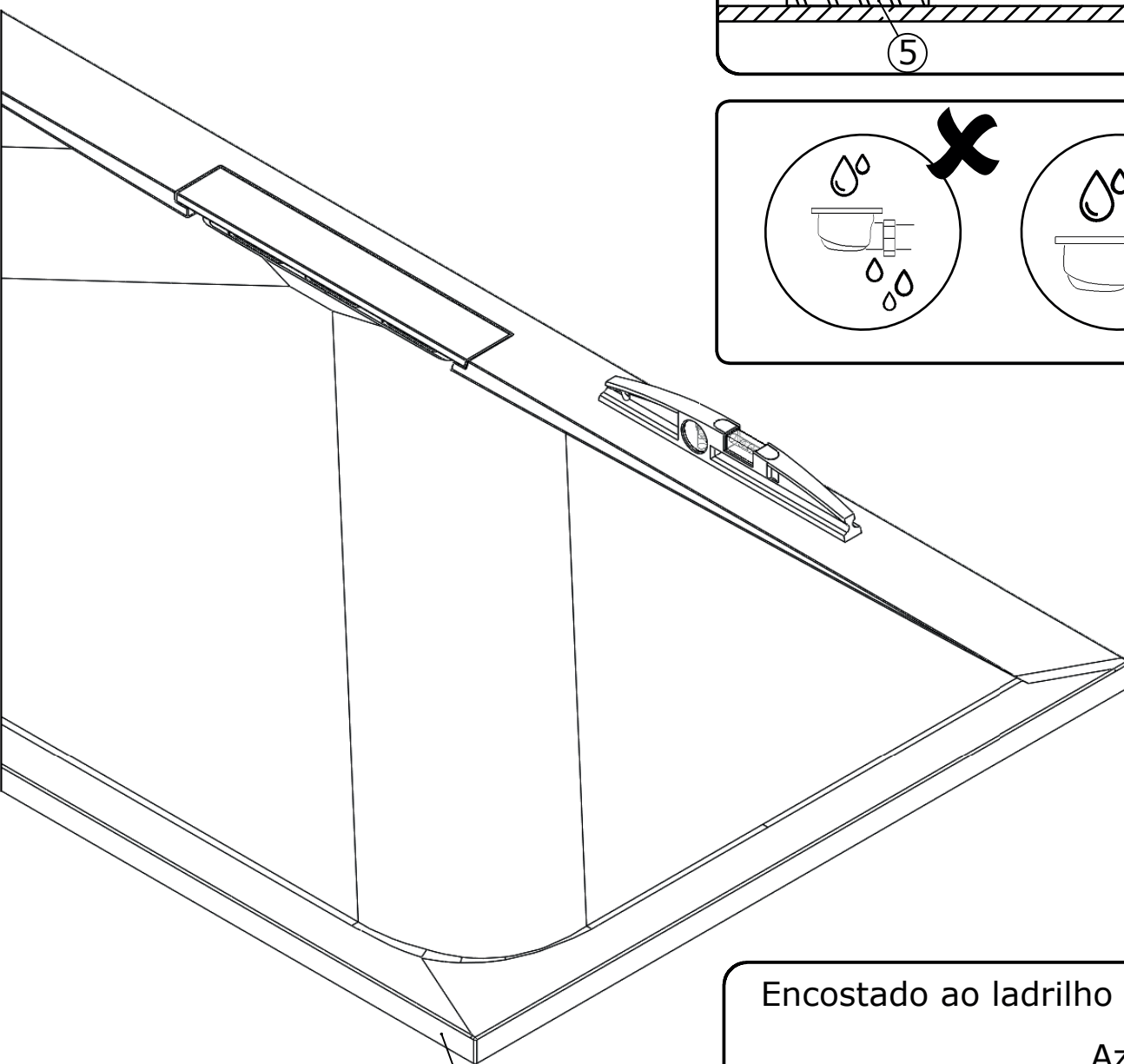
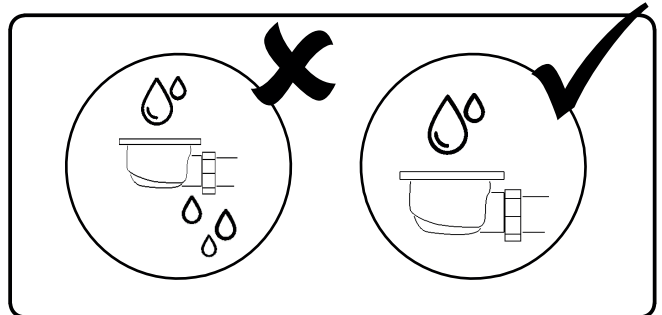
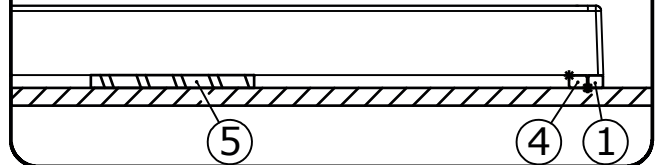

Encostado ao ladrilho

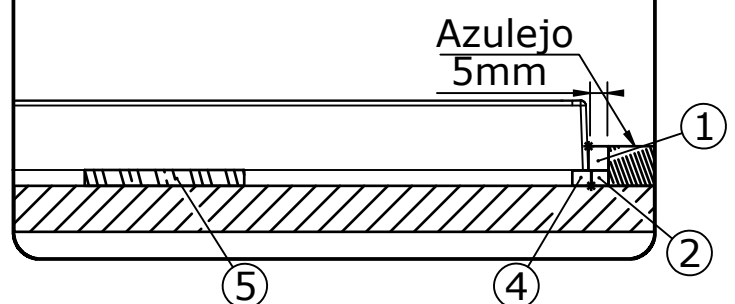

Piso rígido, indispensável

TIPO DE INSTALAÇÕES

KINELINE QUADRADO, RECTANGULAR DRENO CENTRADO NA COMPRIMENTO

1. Instalado em pés ajustáveis com cobertura de azulejo

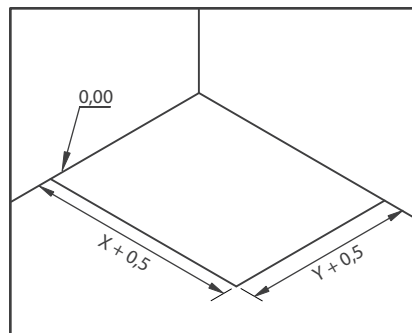
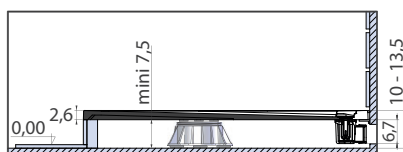

X	Y	C	D
80	80	68	21,5
90	90	78	26,5
140	80	68	51,5
140	90	78	51,5
160	80	68	61,5
160	90	78	61,5
180	80	68	71,5
180	90	78	71,5

Preparação da instalação

2. Instalação direta no solo

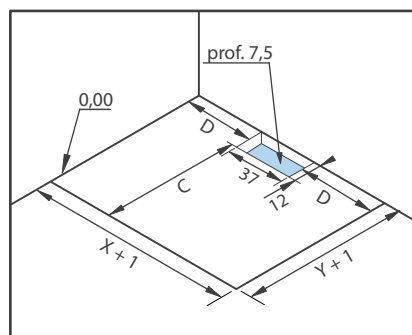
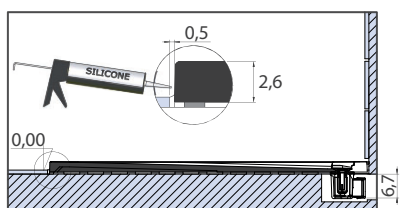
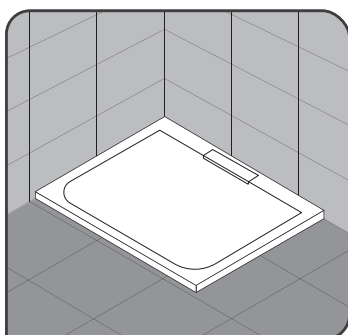

Preparação da instalação

3. Instalação embutida, sobre pés ajustáveis

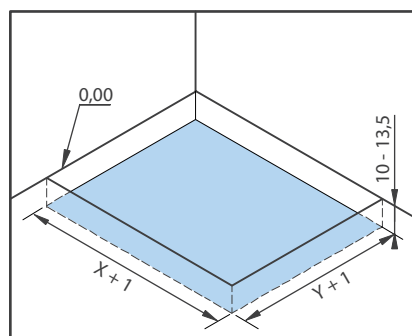
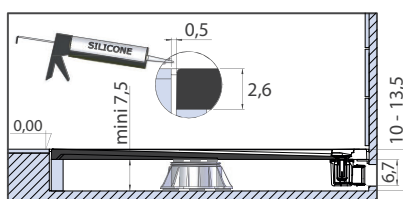

Preparação da instalação

4. Instalação embutida sem pés ajustáveis

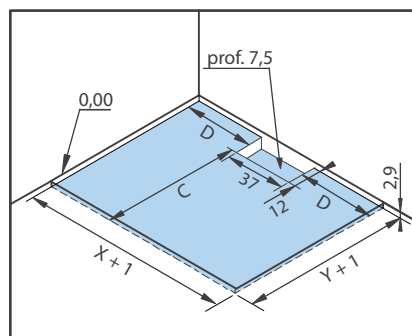
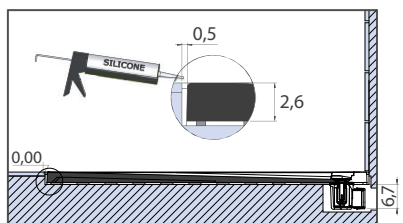
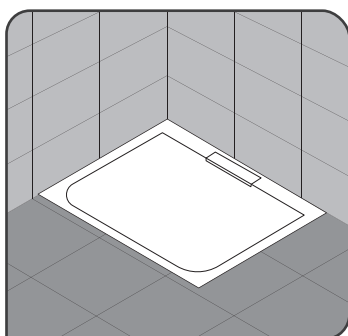

Preparação da instalação

TIPO DE INSTALAÇÕES

KINELINE RECTANGULAR DRENO CENTRADO NA LARGURA

1. Plnstado em pés ajustáveis com cobertura de azulejo

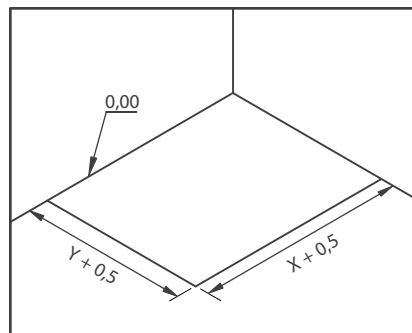
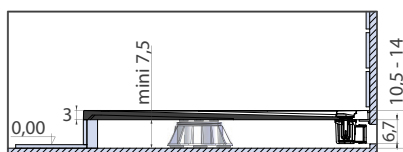

X	Y	C	D
100	80	88	21,5
100	90	88	26,5
120	80	108	21,5
120	90	108	26,5
140	80	128	21,5
140	90	128	26,5
160	80	148	21,5
160	90	148	26,5
180	80	168	21,5
180	90	168	26,5

Preparação da instalação

2. Instalação direta no solo

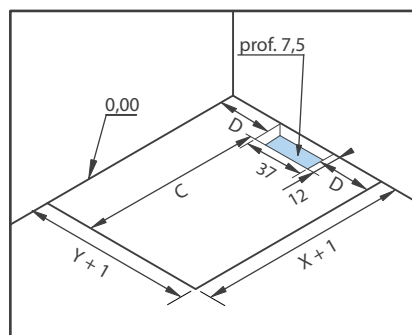
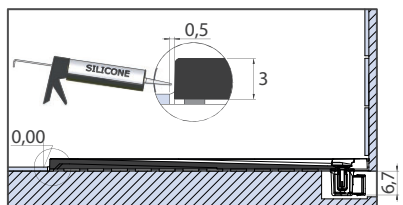
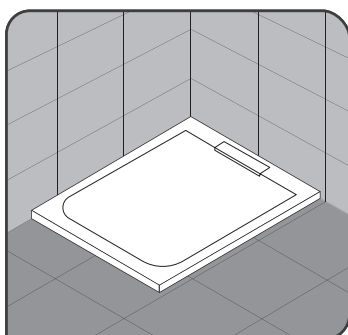

Preparação da instalação

3. Instalação embutida, sobre pés ajustáveis

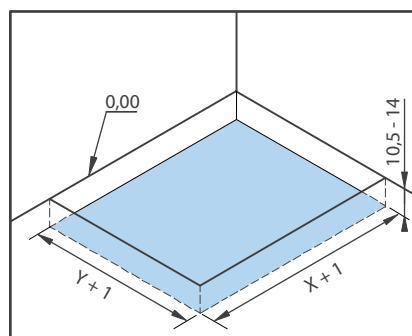
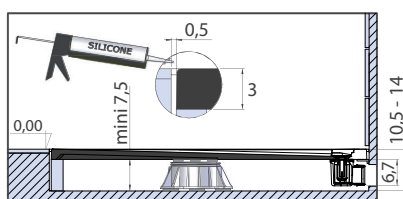

Preparação da instalação

4. Instalação embutida sem pés ajustáveis

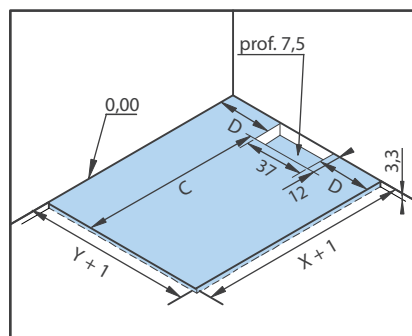
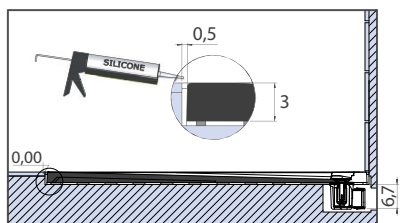
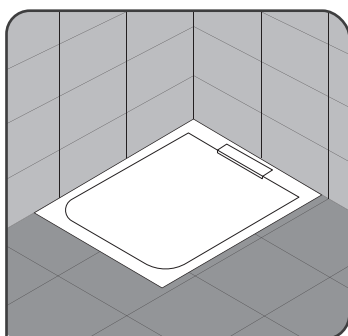

Preparação da instalação

I

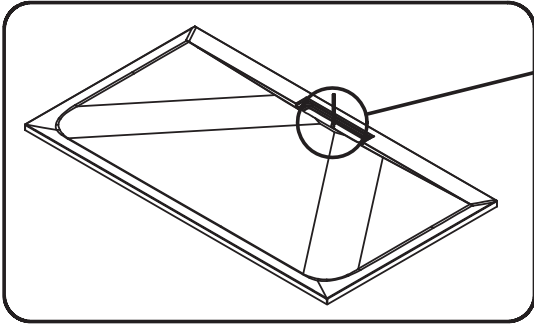

Tracciare la posizione dello scarico e realizzare un montaggio a vuoto dello scarico e del piatto

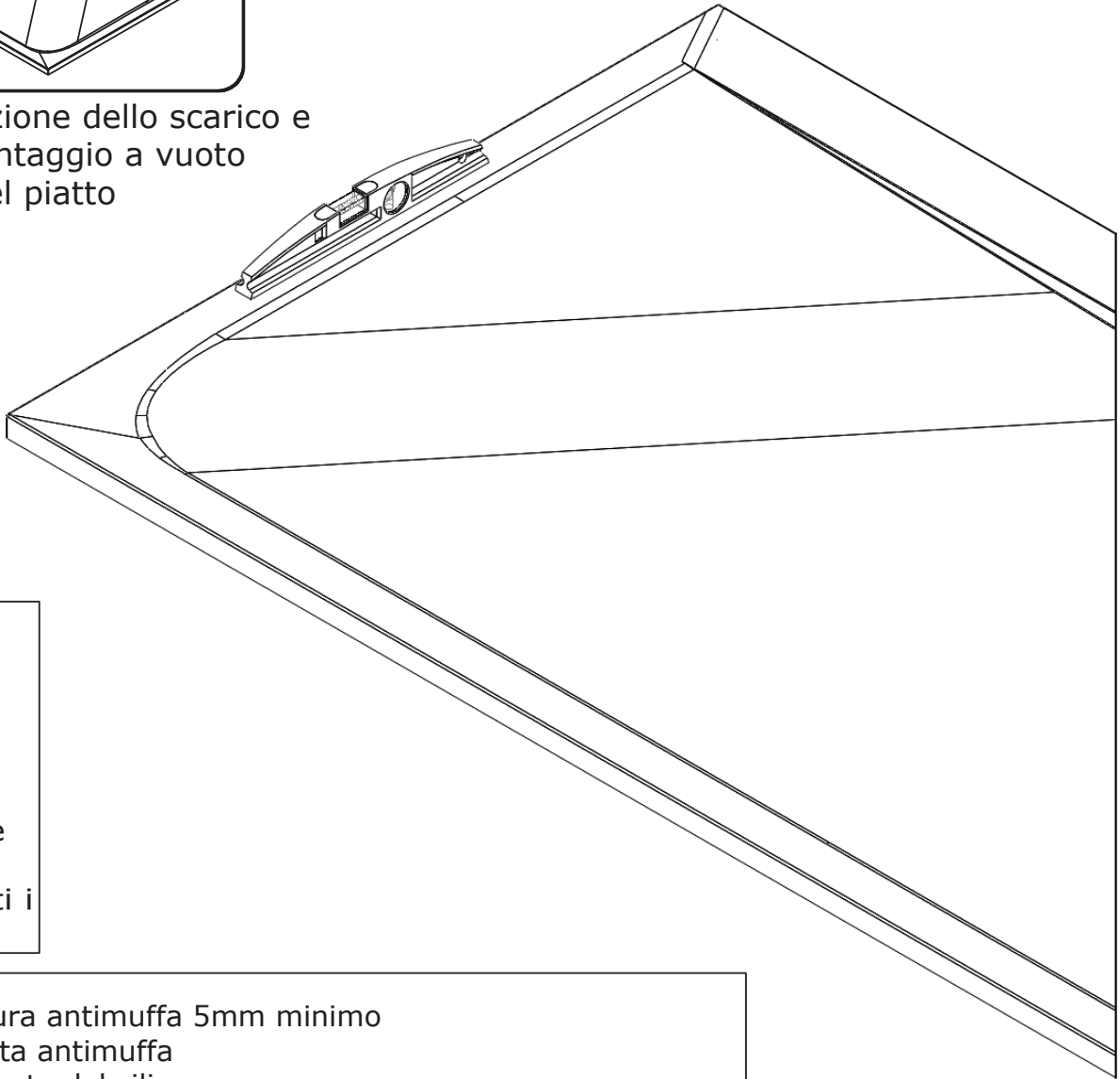

È essenziale avere un supporto inalterabile su tutti i lati del piatto

- ① - silicone di finitura antimuffa 5mm minimo
- ② - silicone di tenuta antimuffa
- ③ - elemento di tenuta del silicone
- ④ - supporto in silicone
- ⑤ - colla poliuretanica o MS polimero

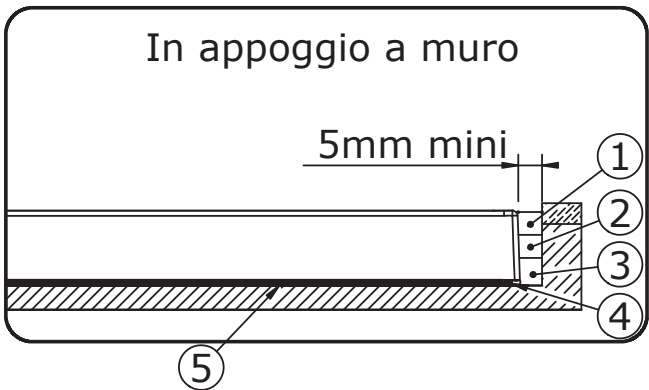
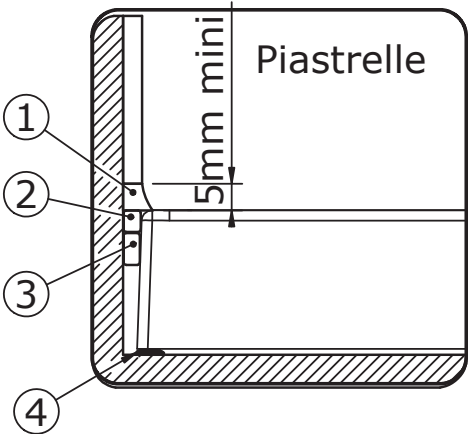



Durante la posa proteggere il piatto da graffi, colpi, attrezzi, bruciature ...



Il montaggio di una valvola di sicurezza è richiesto per un uso ottimale se un altre utenze sono collegate allo stesso scarico.

Non utilizzare acido cloridrico o forti sgrassatori

Posa diretta al suolo

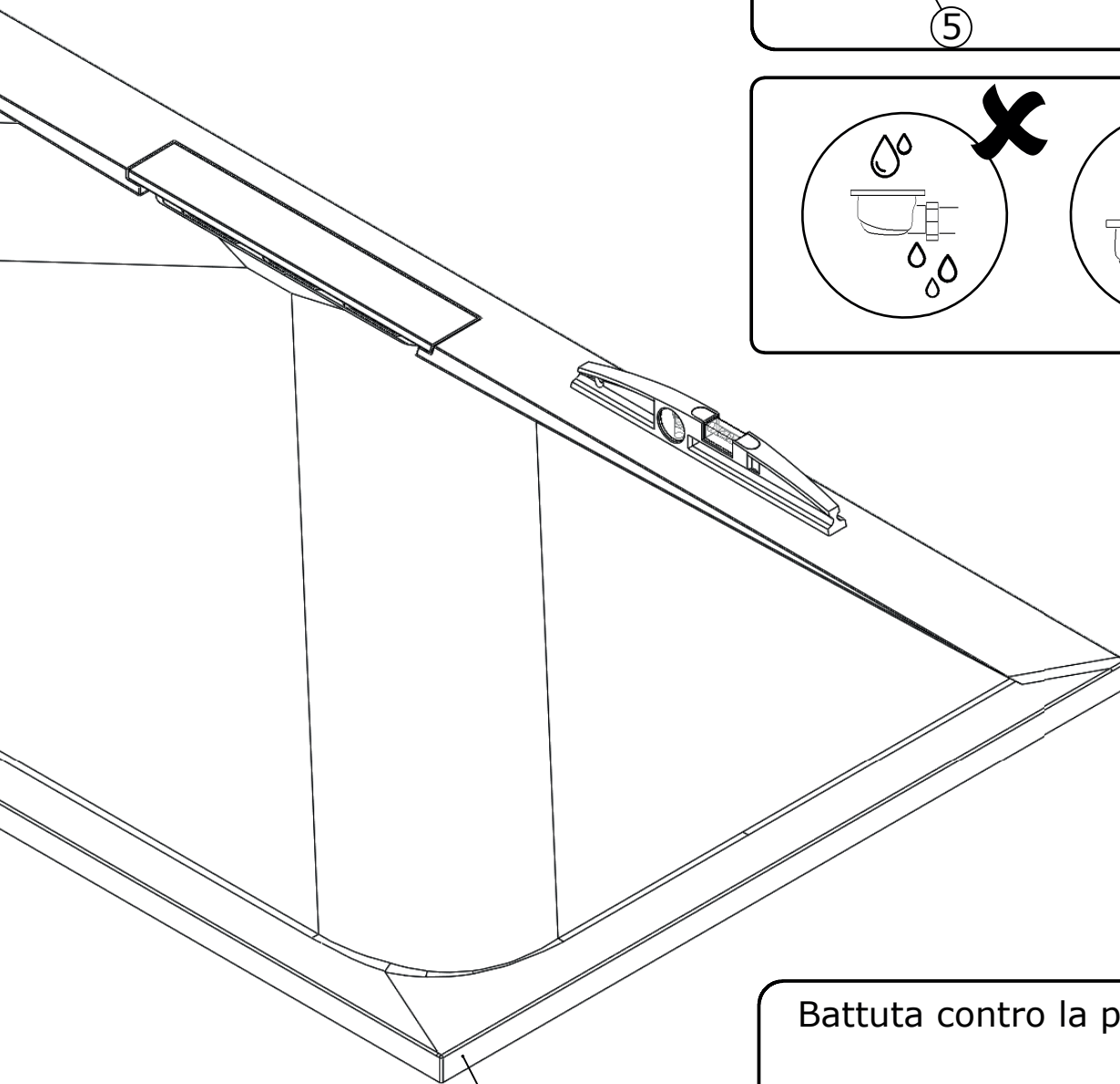
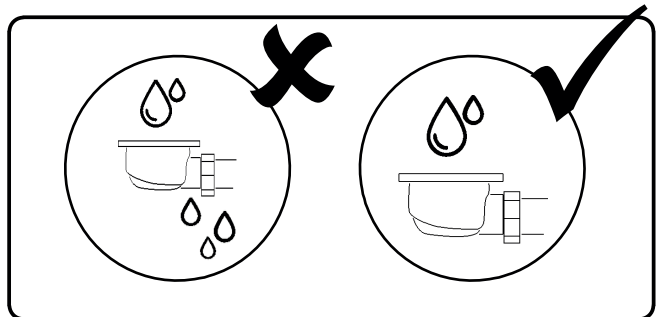
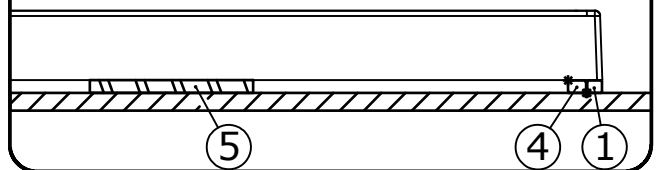

Suolo robusto e non umido

Battuta contro la piastrella

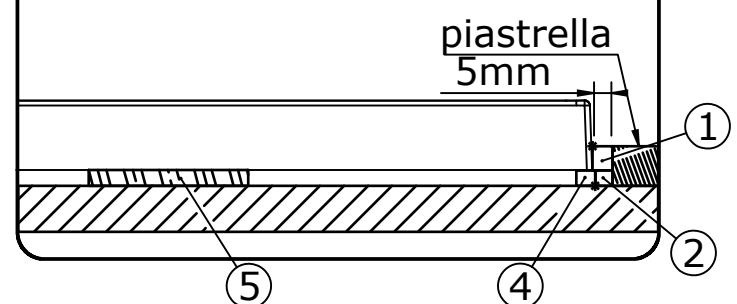

TIPI DI INSTALLAZIONE

KINELINE QUADRATO, RETTANGOLARE DRENAGGIO CENTRATO SULLA LUNGHEZZA

1. Montato su piedini regolabili con rivestimento in piastrelle

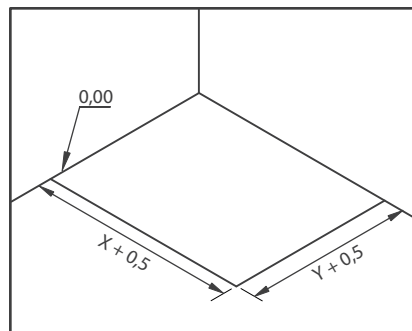
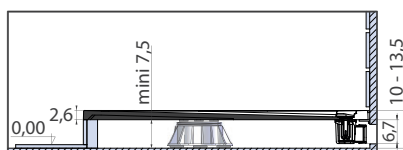

X	Y	C	D
80	80	68	21,5
90	90	78	26,5
140	80	68	51,5
140	90	78	51,5
160	80	68	61,5
160	90	78	61,5
180	80	68	71,5
180	90	78	71,5

Predisposizione impianto

2. Installato in appoggio a pavimento

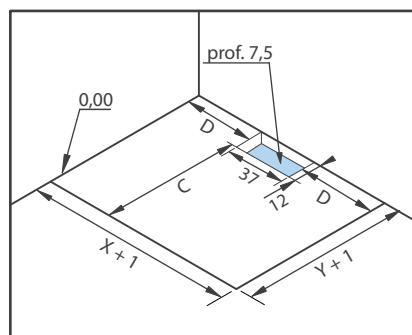
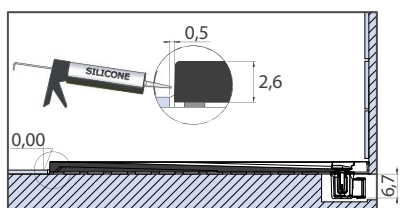
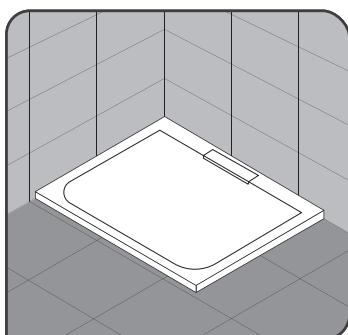

Predisposizione impianto

3. Incassato e posizionato su piedini regolabili

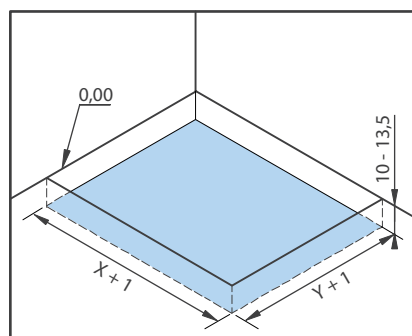
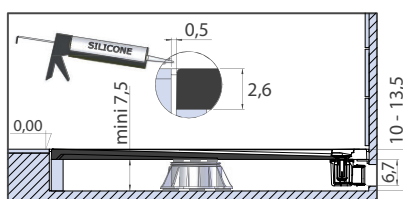

Predisposizione impianto

4. Installato a filo pavimento

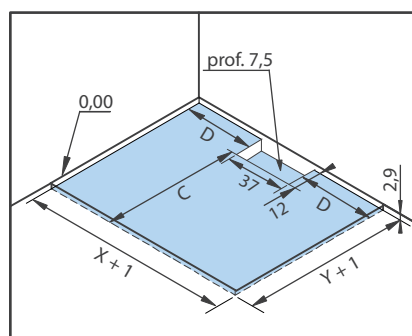
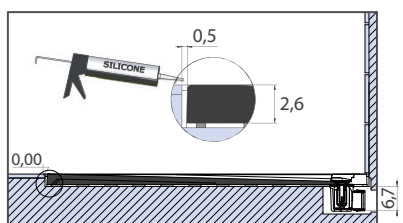
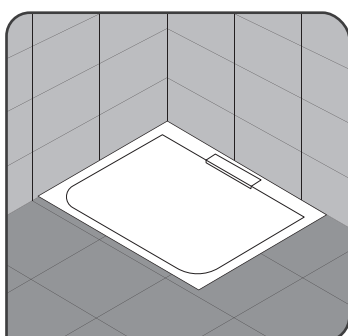

Predisposizione impianto

TIPI DI INSTALLAZIONE

KINELINE RETTANGOLARE DRENAGGIO CENTRATO SULLA LARGHEZZA

1. Montato su piedini regolabili con rivestimento in piastrelle

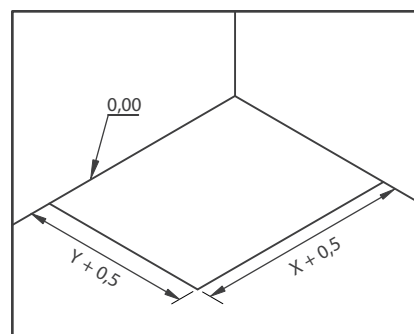
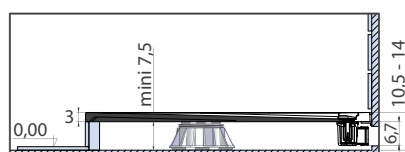

X	Y	C	D
100	80	88	21,5
100	90	88	26,5
120	80	108	21,5
120	90	108	26,5
140	80	128	21,5
140	90	128	26,5
160	80	148	21,5
160	90	148	26,5
180	80	168	21,5
180	90	168	26,5

Predisposizione impianto

2. Installato in appoggio a pavimento

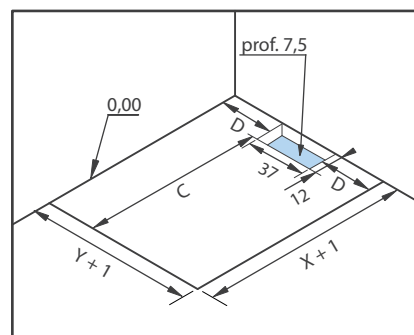
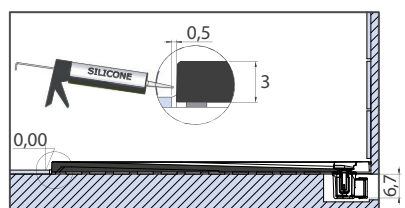
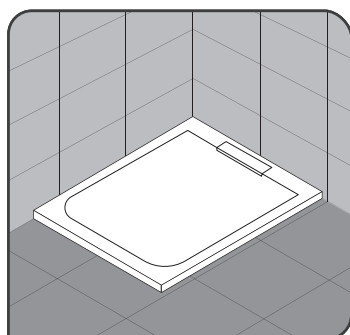

Predisposizione impianto

3. Incassato e posizionato su piedini regolabili

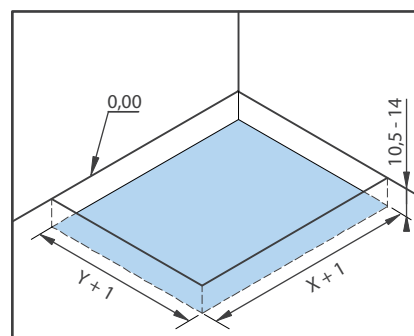
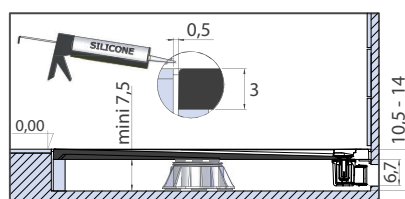

Predisposizione impianto

4. Installato a filo pavimento

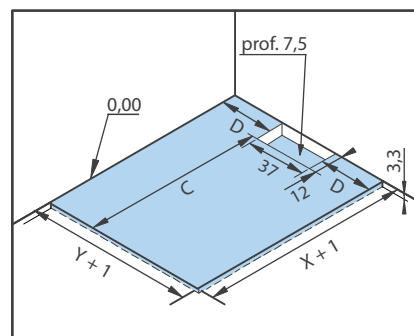
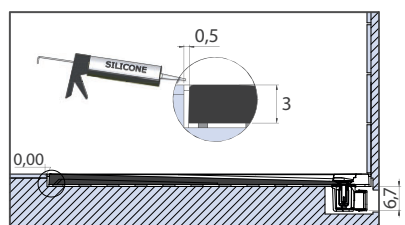
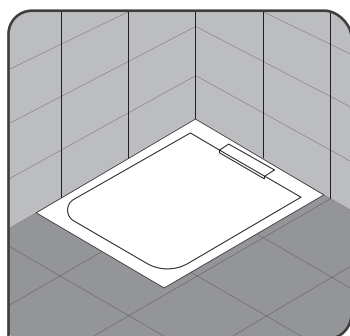

Predisposizione impianto

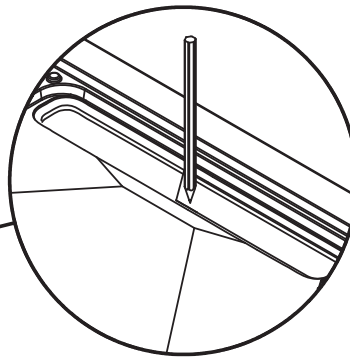
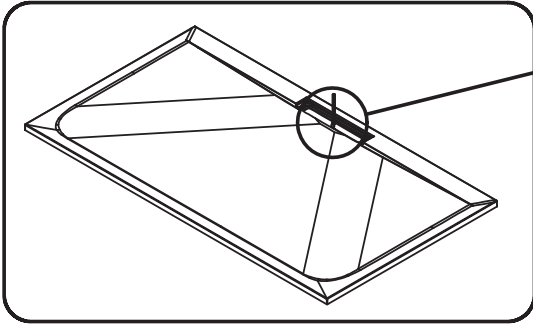

Markeer de positie van de afvoer en
situeer de afvoer en de douchebak
op de gewenste plaats

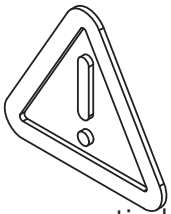
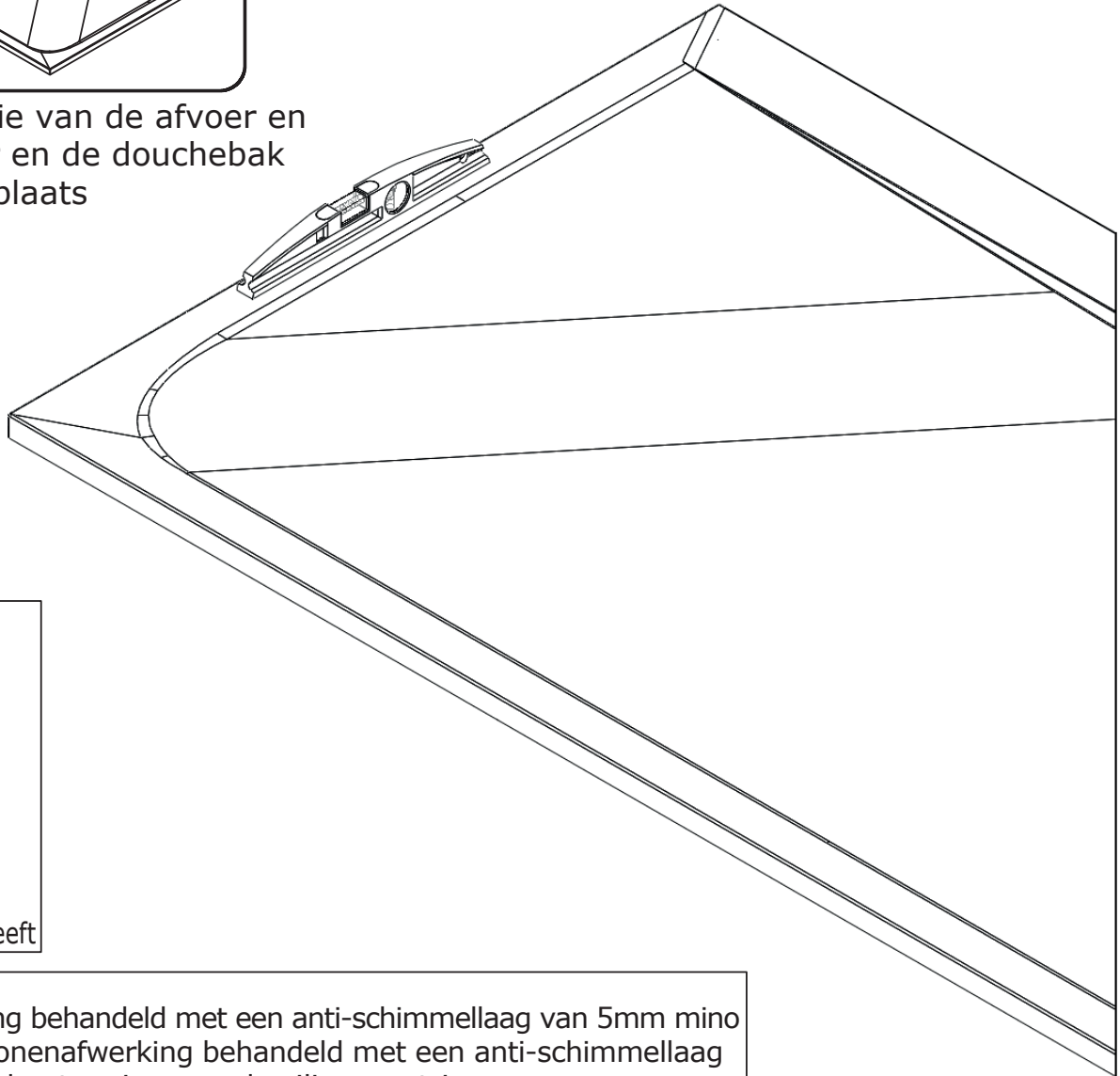

Het is van essentieel
belang dat de douchebak
aan de zijkanten een
ondoordringbare steun heeft

- ① - siliconenafwerking behandeld met een anti-schimmellaag van 5mm mino
- ② - waterdichte siliconenafwerking behandeld met een anti-schimmellaag
- ③ - element ter ondersteuning van de siliconenstrip
- ④ - aanbrengen van siliconenkit
- ⑤ - polyurethaan lijm of MS ployleer

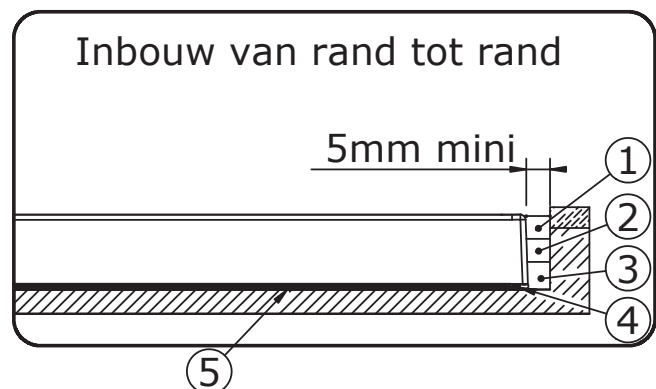
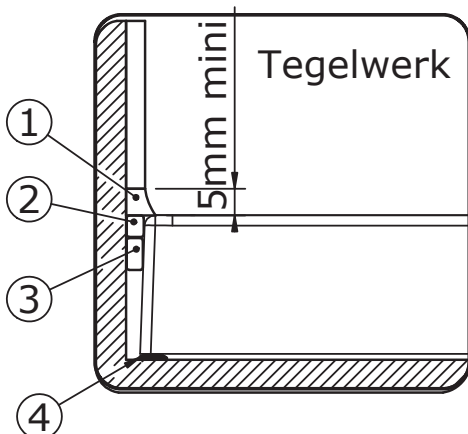



Bescherm de douchebak tijdens de werkzaamheden tegen brandplekken, schokken en beschadigingen door krassen etc...



De Montage van een afdichtingsklep/ventiel is noodzakelijk voor optimaal gebruik indien men een ander sanitair product wil aansluiten op dezelfde afvoer.

Geen chloorhoudende producten en ontvetters gebruiken!

Plaatsing direct op de vloer

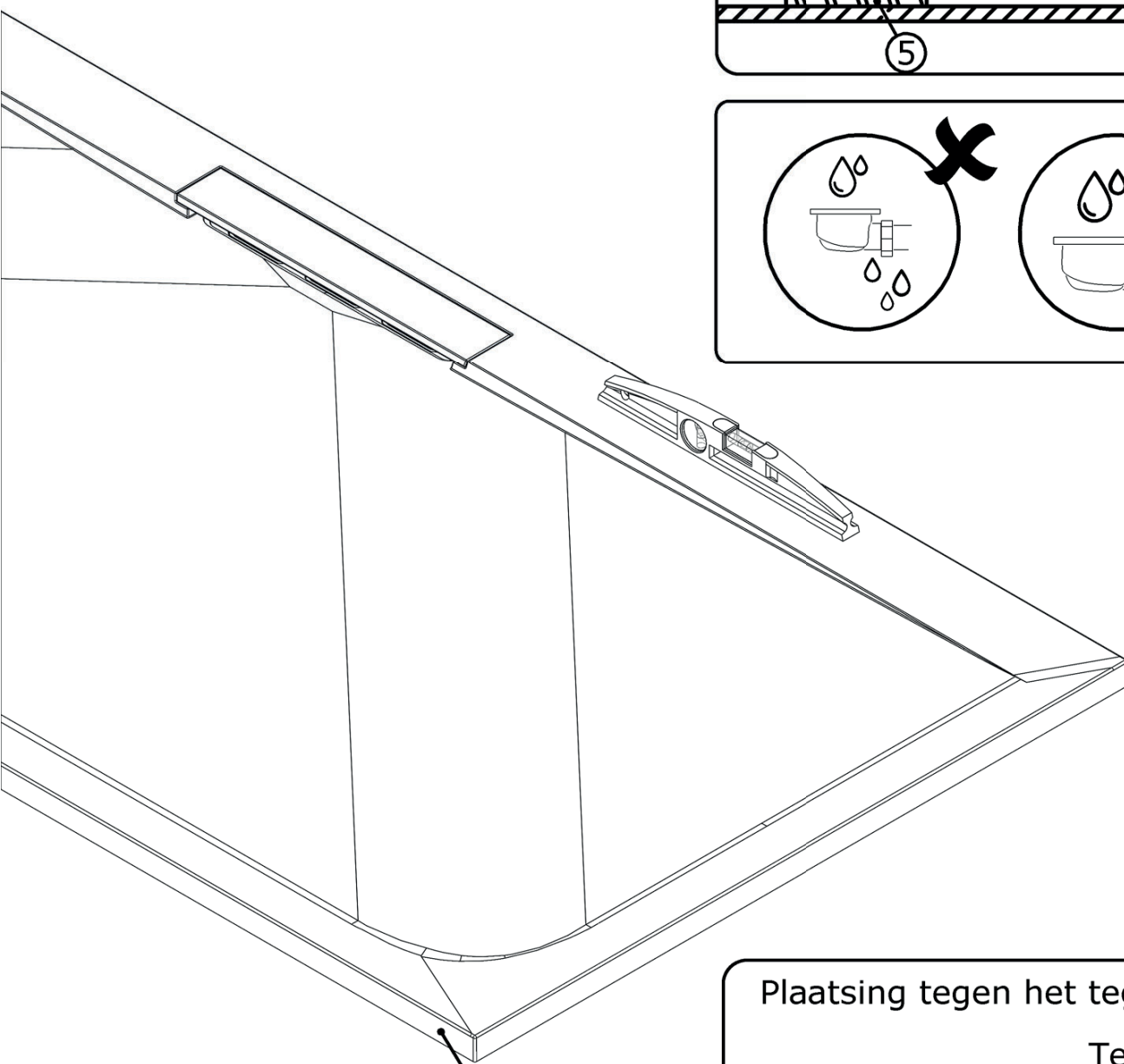
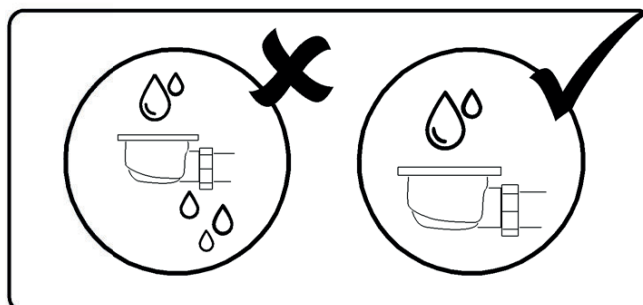
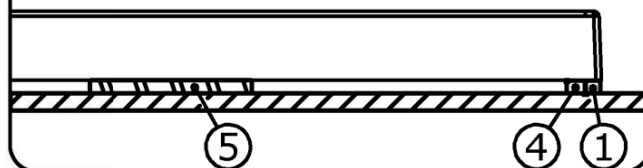

Vlakke niet-vochtige vloer is essentieel

Plaatsing tegen het tegelwerk

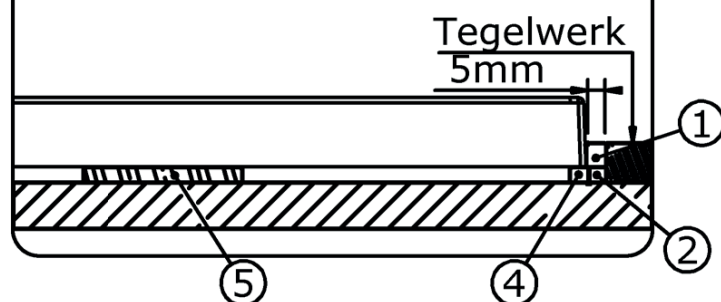

INSTALLATIEMOGELIJKHEDEN

KINELINE VIERKANT, RECHTHOEKIGE AFVOER GECENTREERD OP LENGTE

1. Geïnstalleerd op in hoogte verstelbare poten en afgewerkt met tegels

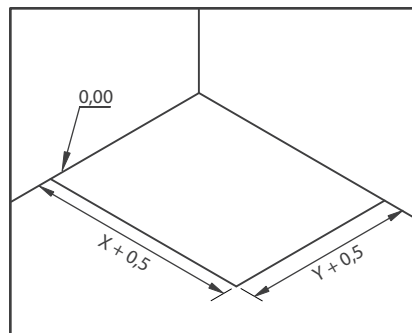
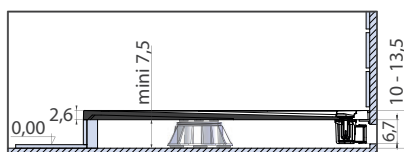

X	Y	C	D
80	80	68	21,5
90	90	78	26,5
140	80	68	51,5
140	90	78	51,5
160	80	68	61,5
160	90	78	61,5
180	80	68	71,5
180	90	78	71,5

Voorbereiding montage

2. Geïnstalleerd half verzonken tegen de tegels

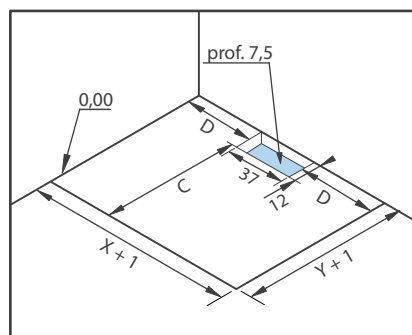
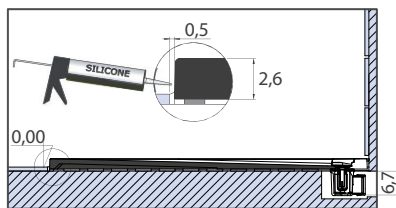
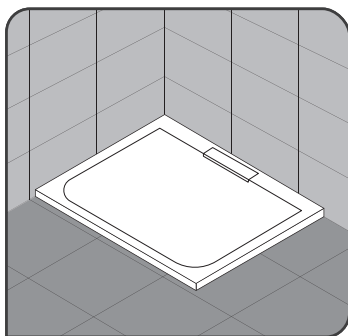

Voorbereiding montage

3. Ingebouwd met in hoogte verstelbare poten

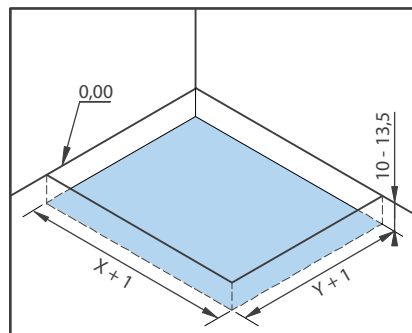
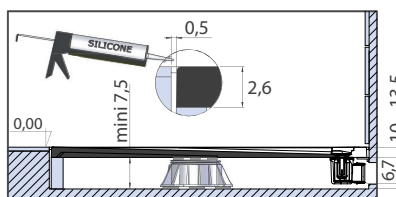

Voorbereiding montage

4. Ingebouwd zonder in hoogte verstelbare poten

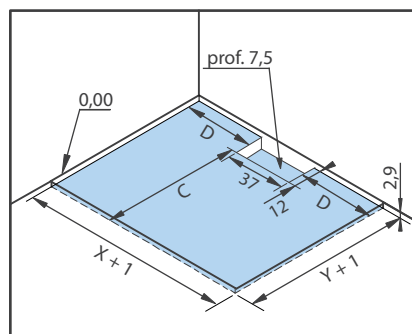
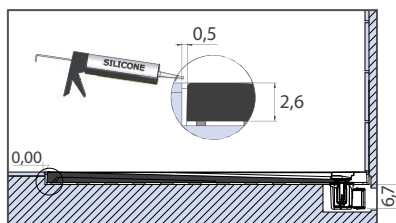
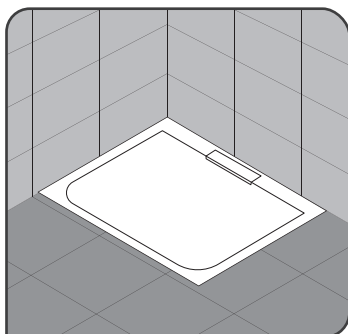

Voorbereiding montage

INSTALLATIEMOGELIJKHEDEN

KINELINE RECHTHOEKIGE AFVOER GECENTREERD OP BREEDTE

1. Geïnstalleerd op in hoogte verstelbare poten en afgewerkt met tegels

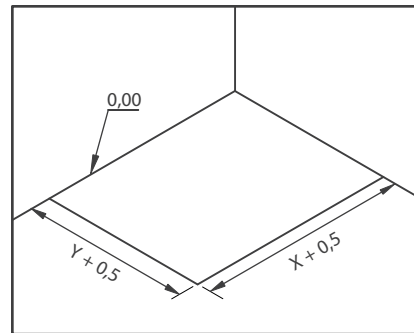
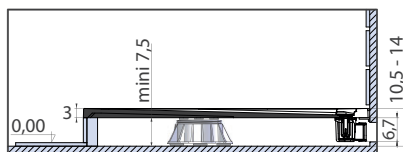

X	Y	C	D
100	80	88	21,5
100	90	88	26,5
120	80	108	21,5
120	90	108	26,5
140	80	128	21,5
140	90	128	26,5
160	80	148	21,5
160	90	148	26,5
180	80	168	21,5
180	90	168	26,5

Vorbereitung montage

2. Geïnstalleerd half verzonken tegen de tegels

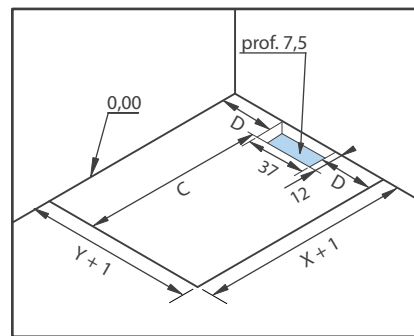
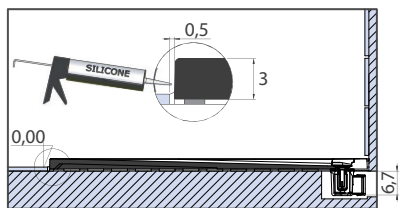
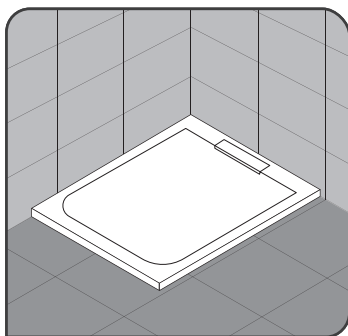

Vorbereitung montage

3. Ingebouwd met in hoogte verstelbare poten

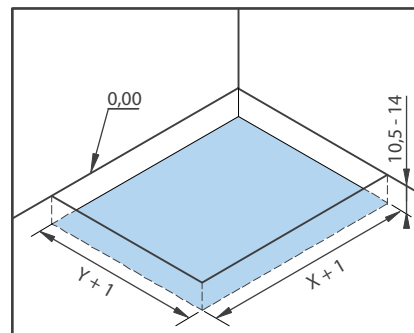
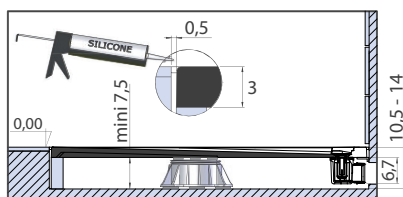

Vorbereitung montage

4. Ingebouwd zonder in hoogte verstelbare poten

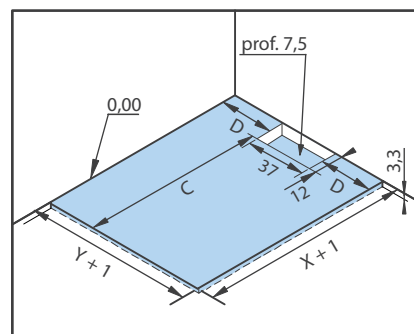
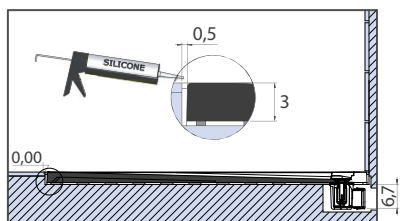
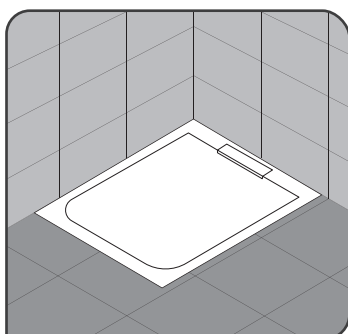

Vorbereitung montage

D

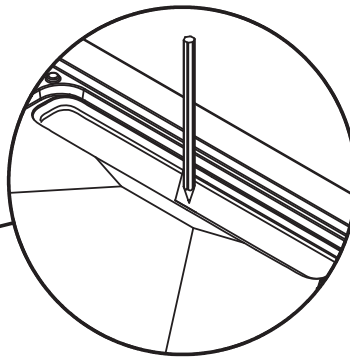
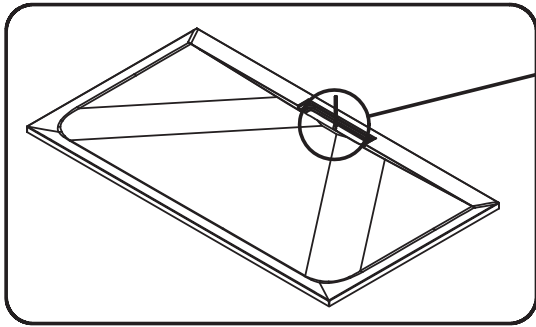

Position für den Ablauf anzeichnen und vormontieren.

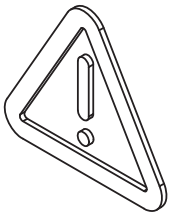
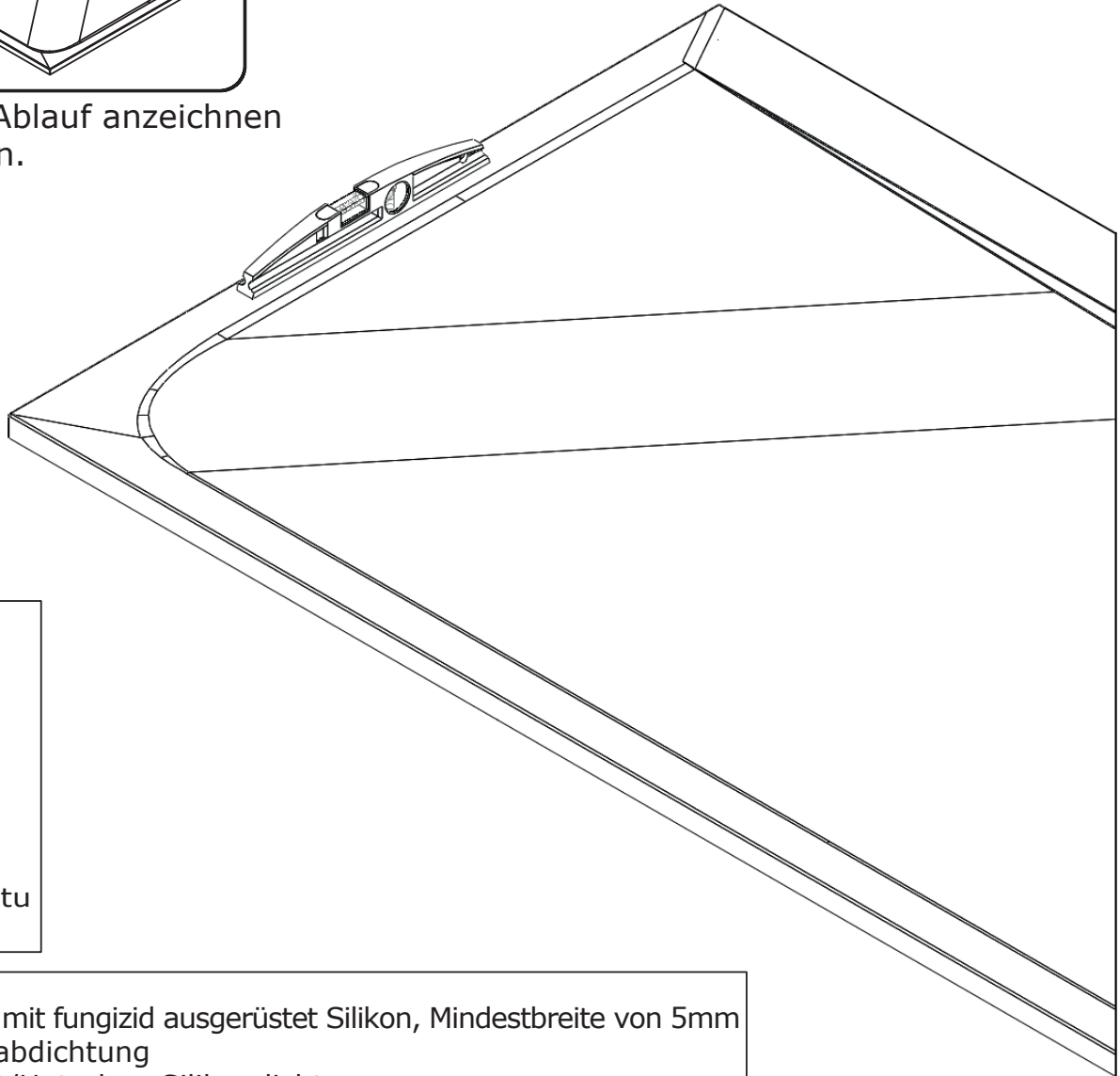

Wandanschlüsse umlaufend mit Wannensrandabdichtung zu versehen.

- ① - Fugenabschluss mit fungizid ausgerüstet Silikon, Mindestbreite von 5mm
- ② - flexible Silikonabdichtung
- ③ - Träger Element/Unterbau Silikondichtung
- ④ - Silikonträger
- ⑤ - Polyurethan-Klebstoff oder MS-Polymer

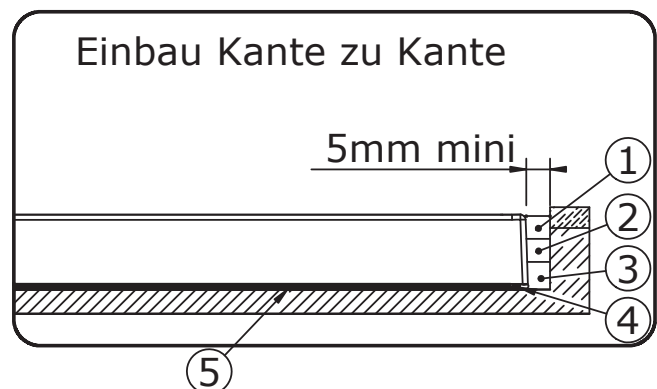
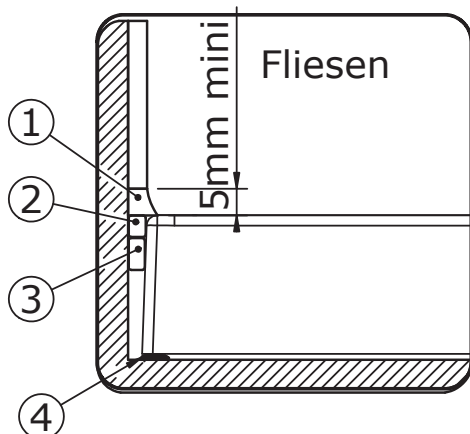

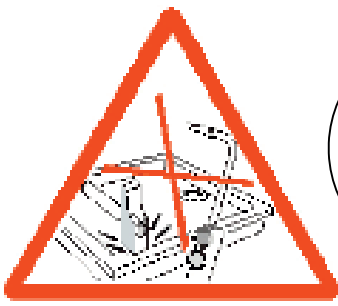

Während den Installationsarbeiten auf ausreichenden Schutz gegen aggressive Mittel achten:
Verbrennungen, Stöße, Kratzer oder Abbeizmittel...



Montage eines Rohrbelüfters einplanen, wenn die Anschlussleitung als Sammelanschlussleitung mehrerer Entwässerungsgegenstände geplant wurde.

Verwenden Sie keine säurehaltigen oder andere aggressive Entfetter.

freie Aufstellung auf Fertigfußboden

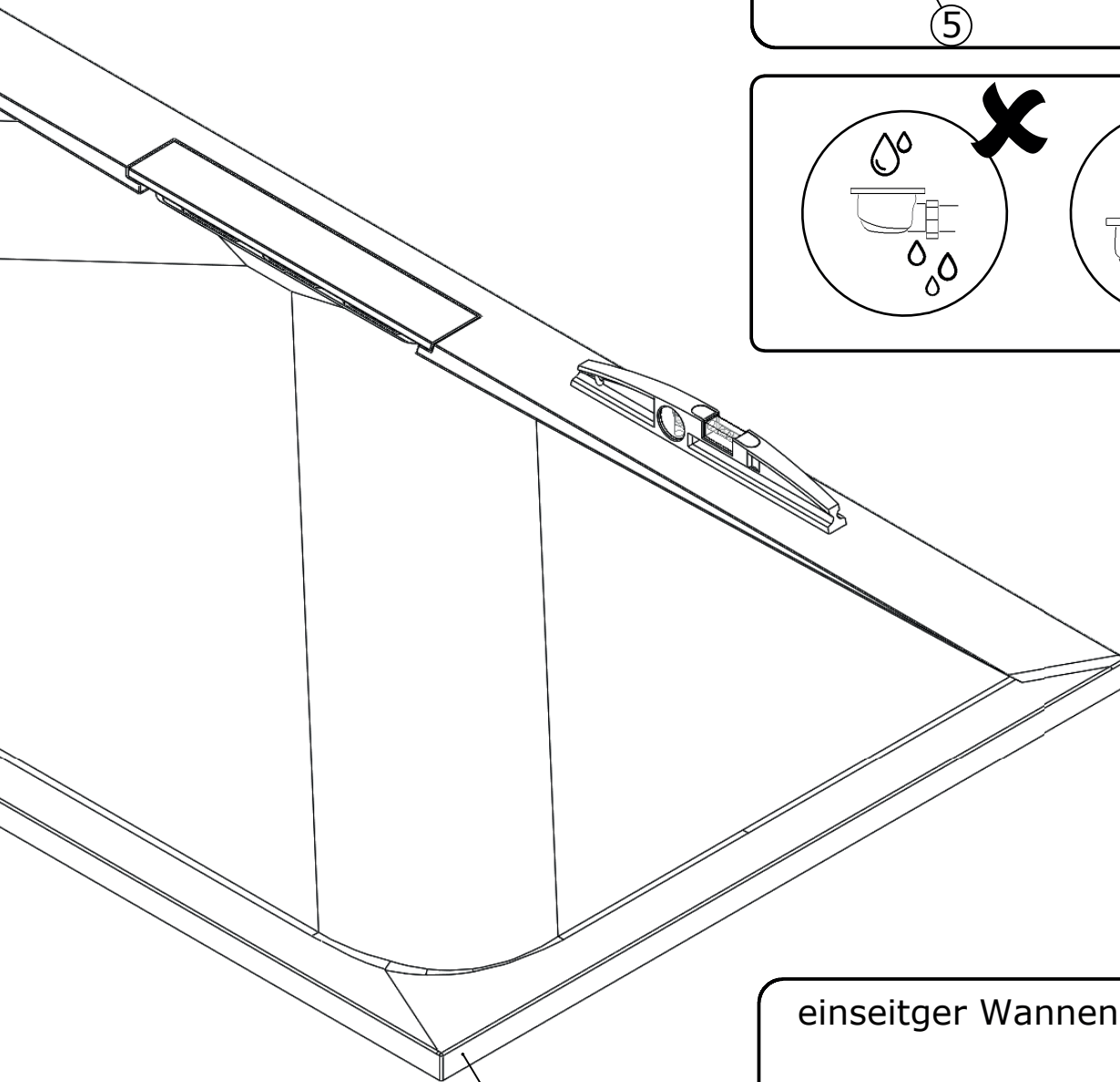
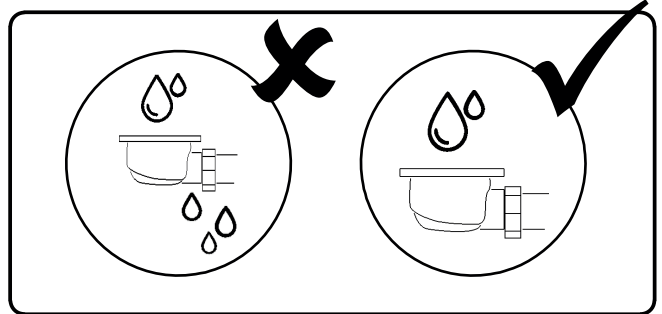
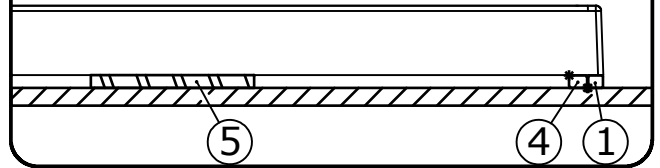

Auf festen, planen und nicht feuchten Boden achten.

einseitiger Wannenanschluß

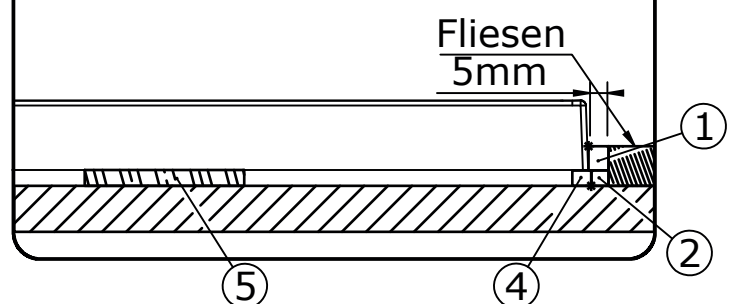

INSTALLATIONSARTEN

KINELINE QUADRATISCH, RECHTECKIG ABLAUF ZENTRIERT AUF LÄNGE

1. Montage auf Fertigfußboden mit Wannenfüßen und Fliesensockel

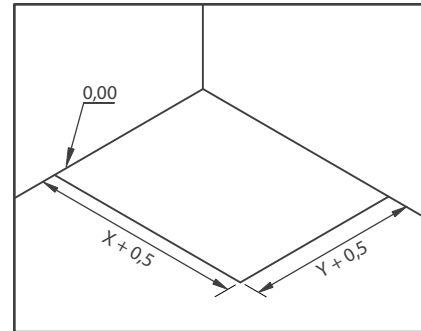
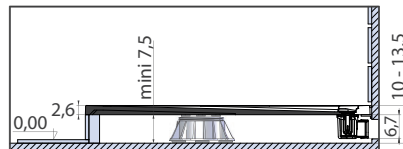

X	Y	C	D
80	80	68	21,5
90	90	78	26,5
140	80	68	51,5
140	90	78	51,5
160	80	68	61,5
160	90	78	61,5
180	80	68	71,5
180	90	78	71,5

Montagevorbereitung Fertigfußboden mit Wannenfüße

2. Wird im Widerlager gegen die Fliese montiert

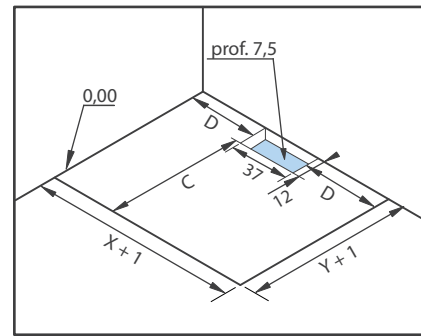
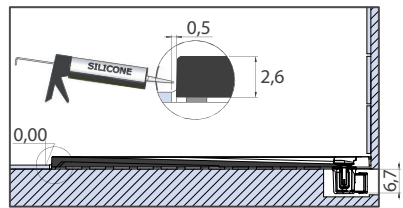
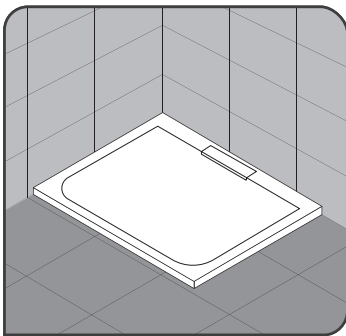

Montagevorbereitung Fertigfußboden mit Wannenfüße

3. Bodengleiche Montage mit Wannenfüße

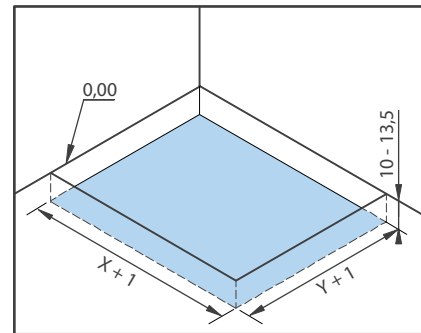
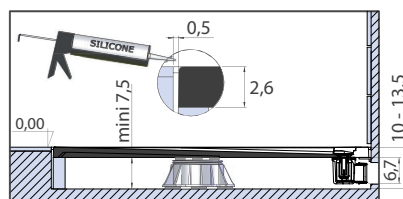

Montagevorbereitung Fertigfußboden mit Wannenfüße

4. Bodengleiche Montage ohne Wannenfüße

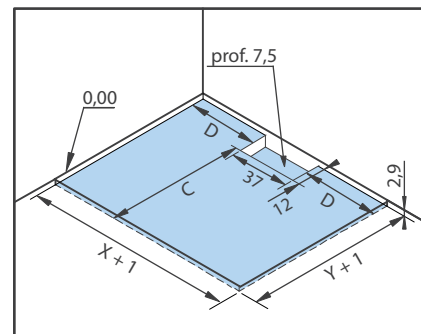
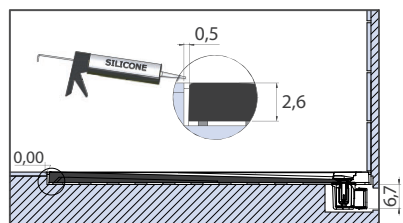
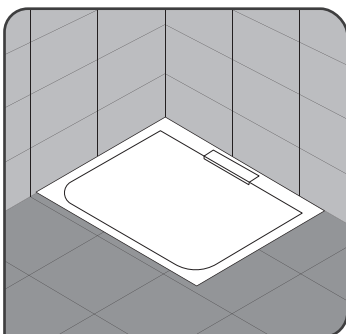

Montagevorbereitung Fertigfußboden mit Wannenfüße

INSTALLATIONSARTEN

KINELINE RECHTECKIG ABLAUF ZENTRIERT AUF BREITE

1. Montage auf Fertigfußboden mit Wannenfüßen und Fliesensockel

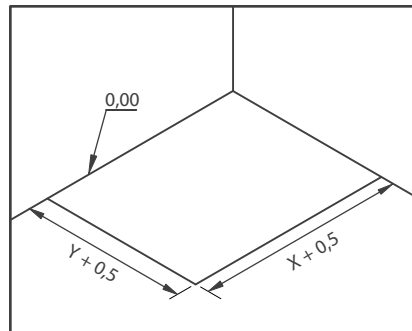
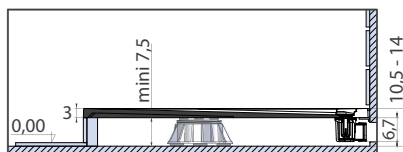

X	Y	C	D
100	80	88	21,5
100	90	88	26,5
120	80	108	21,5
120	90	108	26,5
140	80	128	21,5
140	90	128	26,5
160	80	148	21,5
160	90	148	26,5
180	80	168	21,5
180	90	168	26,5

Montagevorbereitung Fertigfußboden mit Wannenfüße

2. Wird im Widerlager gegen die Fliese montiert

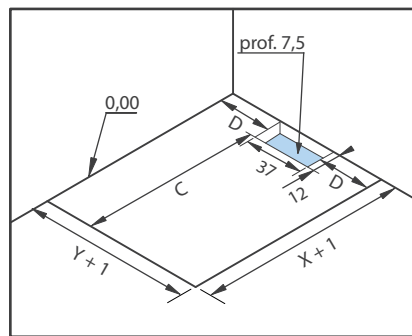
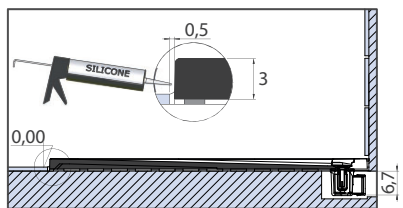
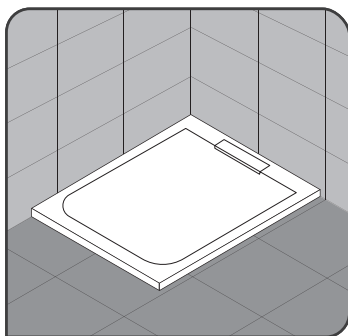

Montagevorbereitung Fertigfußboden mit Wannenfüße

3. Bodengleiche Montage mit Wannenfüße

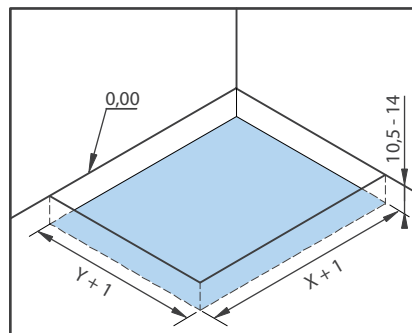
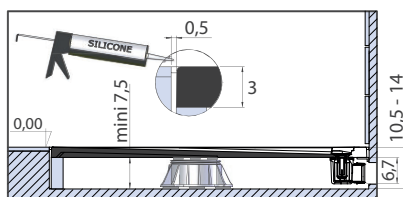

Montagevorbereitung Fertigfußboden mit Wannenfüße

4. Bodengleiche Montage ohne Wannenfüße

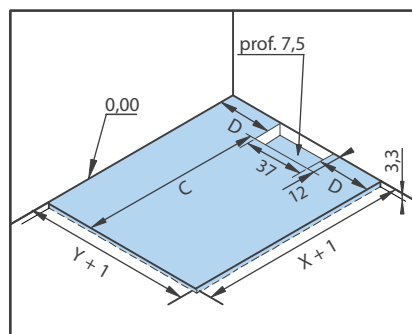
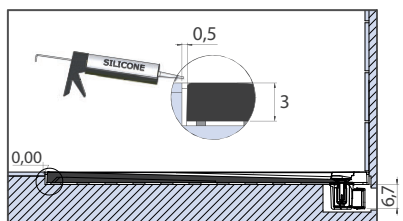
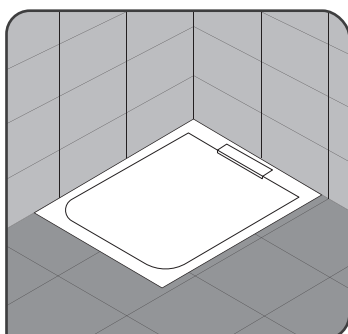

Montagevorbereitung Fertigfußboden mit Wannenfüße

- FR**-Mise en place des plots de colle polyuréthane ou MS polymère
GB-Loading the plots glue polyurethane or MS polymer
ES-Ubicación de los puntos de pegamento poliuretano o polímero MS
PT-Posição dos pontos de cola de poliuretano ou polímero MS
IT-Posizione dei punti di colla poliuretano o MS polímero
NL-Breng de polyurethaan lijm of MS polymeer aan op de juiste plaats
DE-Bringen Sie den Polyurethan-/MS-Polymere-Kleber auf

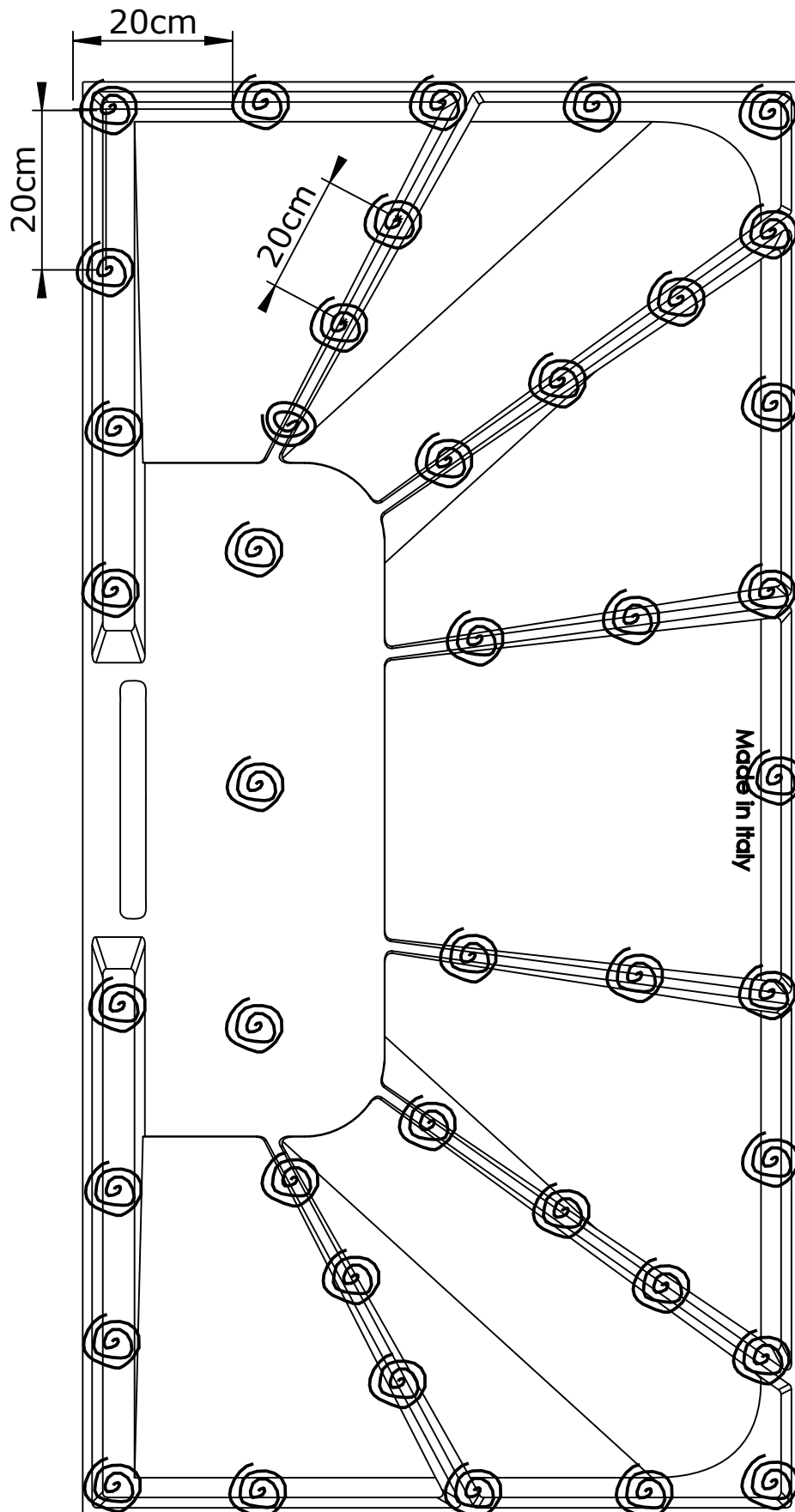

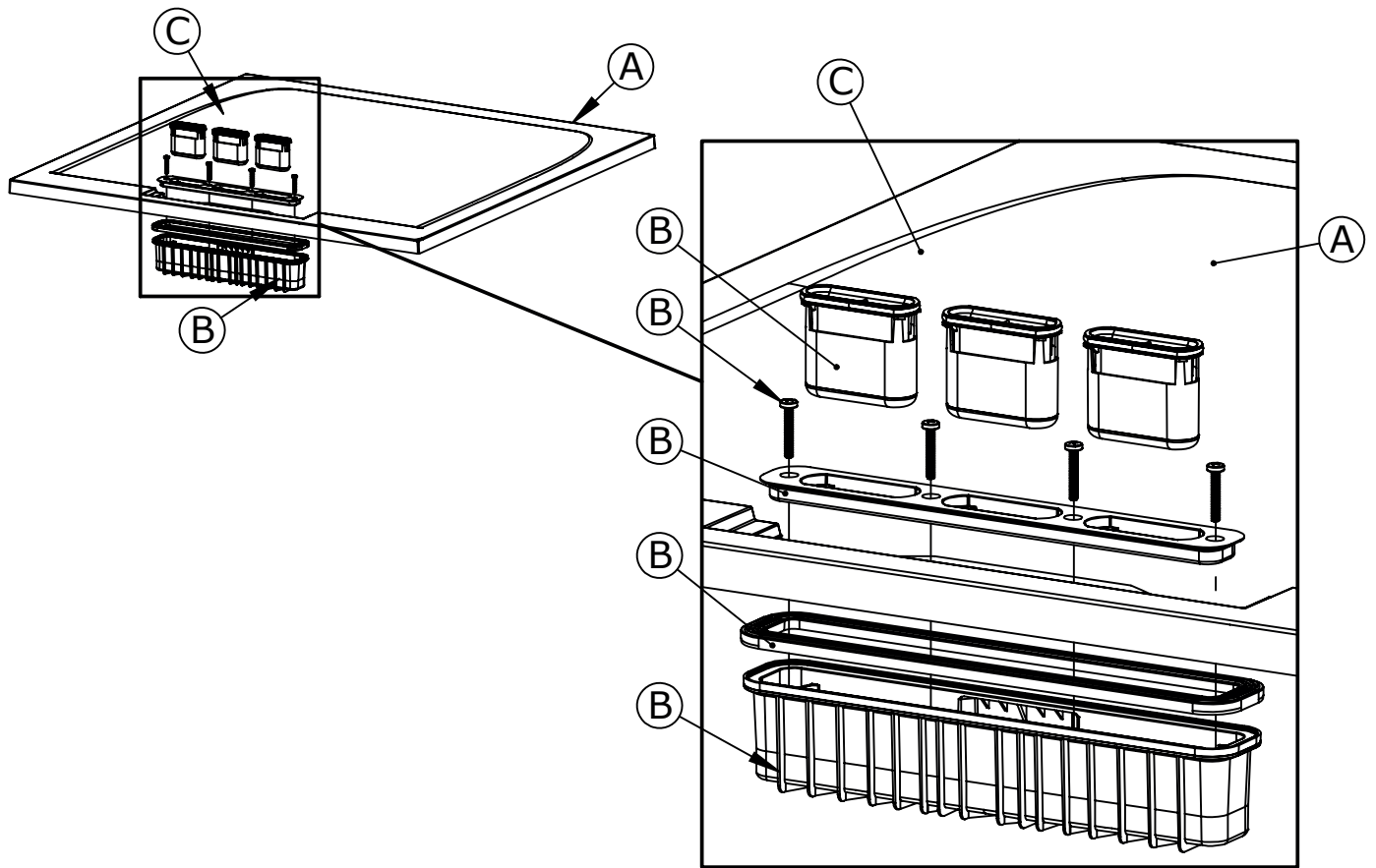

FR-Ou GB-Or ES-O
 PT-Ou IT-O NL-Of.
 DE-Oder.

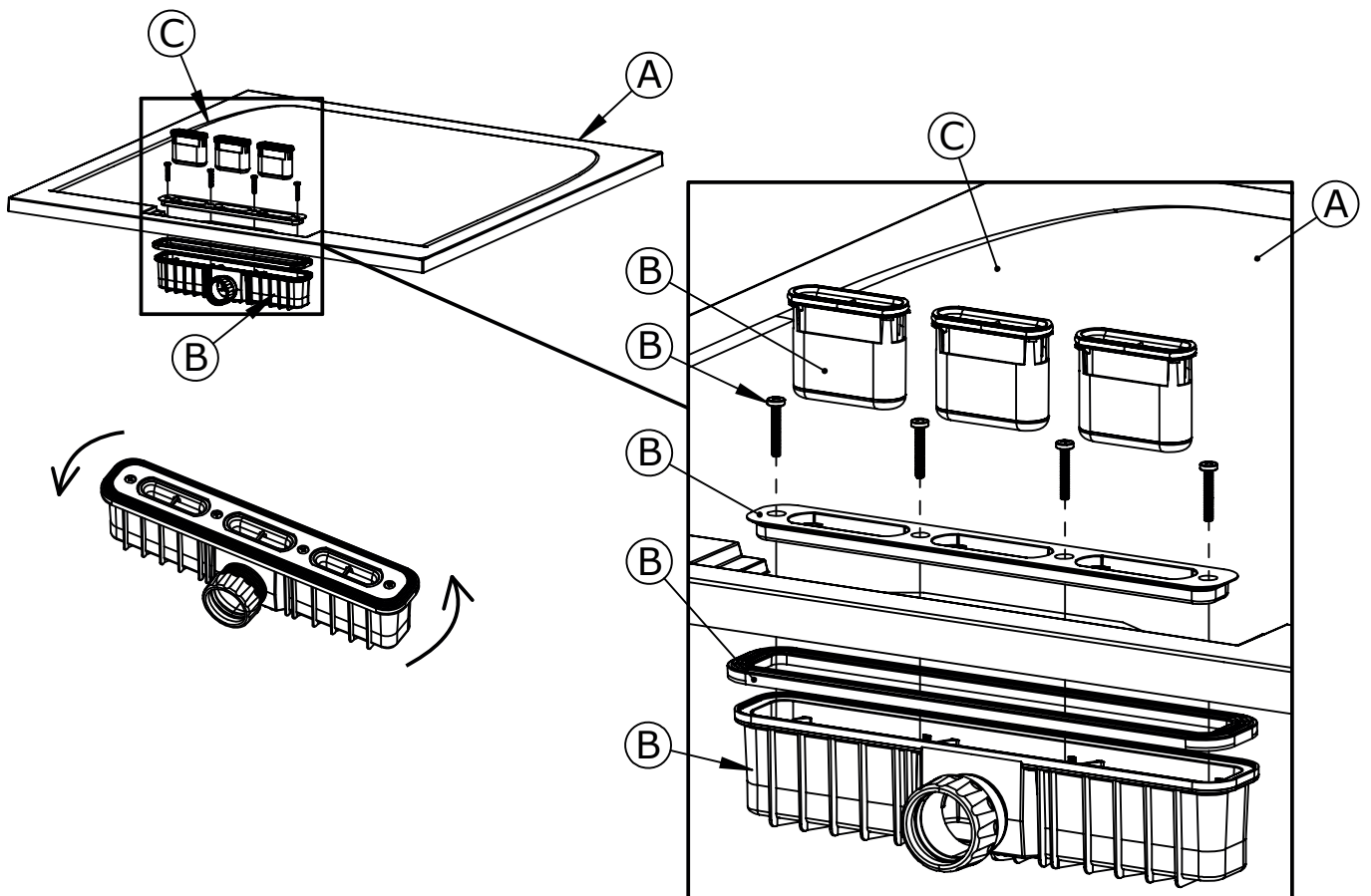



24h

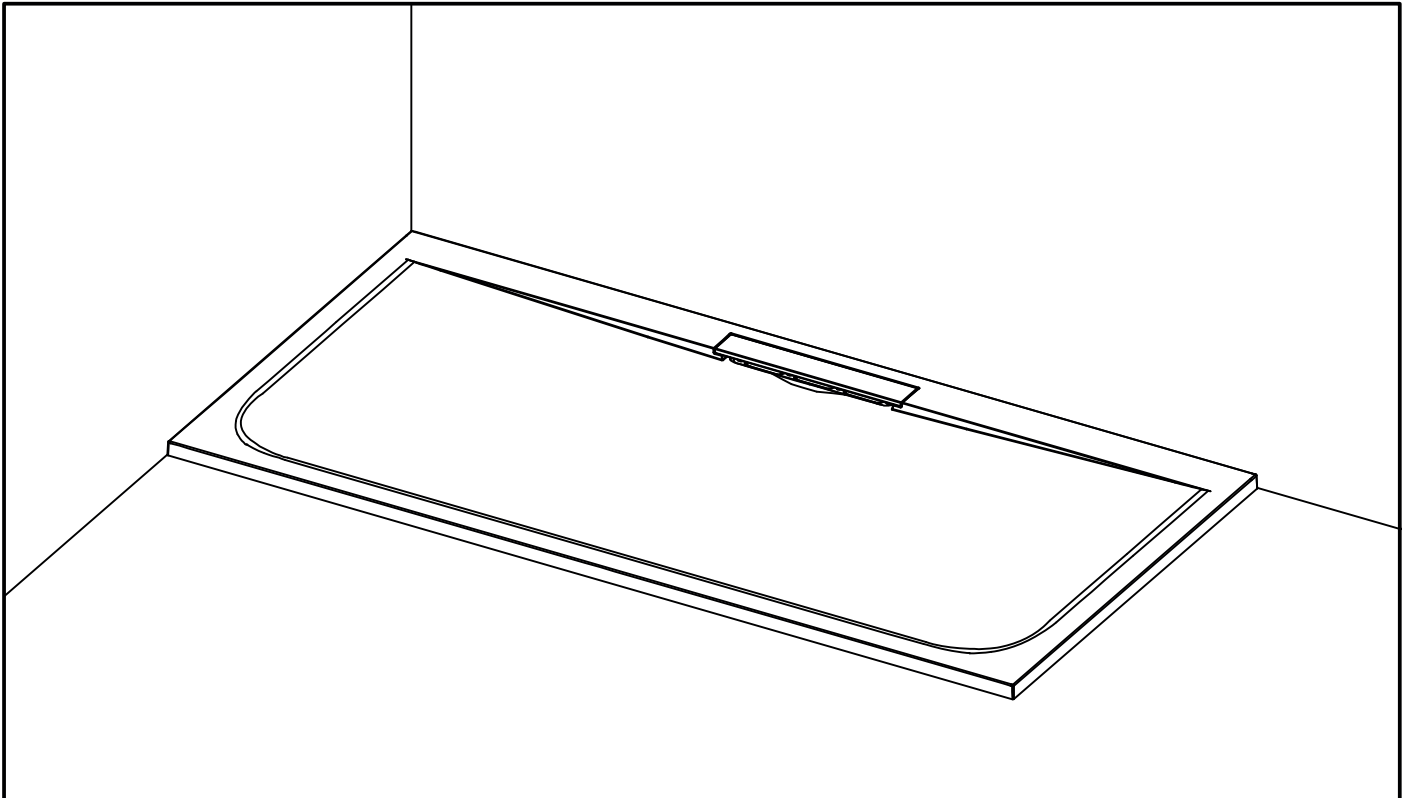



<p>FR</p> <p>Bon de garantie</p> <p>SCANNEZ MOI</p>  <p>http://tiny.cc/bon-de-garantie-fr</p>	<p>GB</p> <p>Guarantee</p> <p>SCAN ME</p>  <p>http://tiny.cc/bon-de-garantie-gb</p>
<p>DE</p> <p>Garantiekarte</p> <p>SCAN MICH</p>  <p>http://tiny.cc/bon-de-garantie-de</p>	<p>NL</p> <p>Garantievoorwaarden</p> <p>SCAN MIJ</p>  <p>http://tiny.cc/bon-de-garantie-nl</p>
<p>ES</p> <p>Garantía</p> <p>ESCANÉAME</p>  <p>http://tiny.cc/bon-de-garantie-es</p>	<p>IT</p> <p>Garanzia</p> <p>SCANSIONAMI</p>  <p>http://tiny.cc/bon-de-garantie-it</p>
<p>PT</p> <p>Garantia</p> <p>ESCANIEI-ME</p>  <p>http://tiny.cc/bon-de-garantie-pt</p>	<p>CH</p> <p>Garantiekarte</p> <p>SCAN MICH</p>  <p>http://tiny.cc/bon-de-garantie-ch</p>
<p>BE</p> <p>Garantievoorwaarden</p> <p>SCAN MIJ</p>  <p>http://tiny.cc/bon-de-garantie-be</p>	<p>AT</p> <p>Garantiekarte</p> <p>SCAN MICH</p>  <p>http://tiny.cc/bon-de-garantie-at</p>



Kinedo

<p>FR Conseils d'entretien</p> <p>SCANNEZ MOI</p>  <p>http://tiny.cc/conseils-entretien-fr</p>	<p>GB Maintenance instructions</p> <p>SCAN ME</p>  <p>http://tiny.cc/conseils-entretien-gb</p>
<p>DE Wartungstipps</p> <p>SCAN MICH</p>  <p>http://tiny.cc/conseils-entretien-de</p>	<p>NL Onderhoudstips</p> <p>SCAN MIJ</p>  <p>http://tiny.cc/conseils-entretien-nl</p>
<p>ES Consejos de mantenimiento</p> <p>ESCANÉAME</p>  <p>http://tiny.cc/conseils-entretien-es</p>	<p>IT Consigli per la manutenzione</p> <p>SCANSIONAMI</p>  <p>http://tiny.cc/conseils-entretien-it</p>
<p>PT Dicas de manutenção</p> <p>ESCANEIE-ME</p>  <p>http://tiny.cc/conseils-entretien-pt</p>	<p>CH Wartungstipps</p> <p>SCAN MICH</p>  <p>http://tiny.cc/conseils-entretien-ch</p>
<p>BE Onderhoudstips</p> <p>SCAN MIJ</p>  <p>http://tiny.cc/conseils-entretien-be</p>	<p>AT Wartungstipps</p> <p>SCAN MICH</p>  <p>http://tiny.cc/conseils-entretien-at</p>



AQUAPRODUCTION, Site industriel,
F - 44680 Chaumes-en-Retz

20

EN 14527 - CL2

Aptitude au nettoyage : satisfaisant

Durabilité : satisfaisant



SERVICE APRÈS-VENTE AFTER-SALES SERVICE

FRANCE

+33 (0)2 40 21 29 45

UK

+44 (0)20 8842 0033

IRELAND

+353 04697 33102

DEUTSCHLAND

+49 (0) 6074 / 30928 0

ITALIA

+39 02 30559420

ÖSTEREICH

+43 1 710 60 70

SUISSE/SCHWEIZ

+41 (0)32 631 04 74

ESPAÑA

+34 93 544 60 76

NEDERLAND

+31 475 487 100

BELGIQUE/BELGIË

+31 475 487 100

РОССИЯ

+7 495 258-29-51

PORTUGAL

+351 219 112 785