

- F Notice de montage ● GB Installation instructions
- E Manual de instalación ● I Istruzioni di montaggio
- NL Montage-instructies ● D Montageanleitung

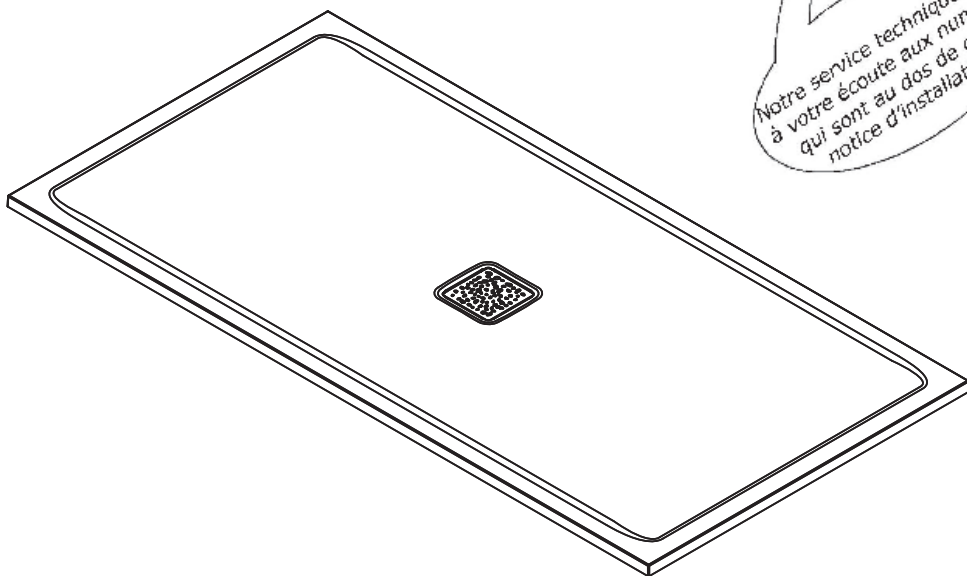

Notre service technique est  
à votre écoute aux numéros  
qui sont au dos de cette  
notice d'installation



- F Attention aux étapes :
- GB Check installation steps :
- E Atención a los pasos :
- I Attenzione ai passi :
- NL Aandacht voor de stappen :
- D Achtung vor den Schritten :

P. 7 - 32 - 33

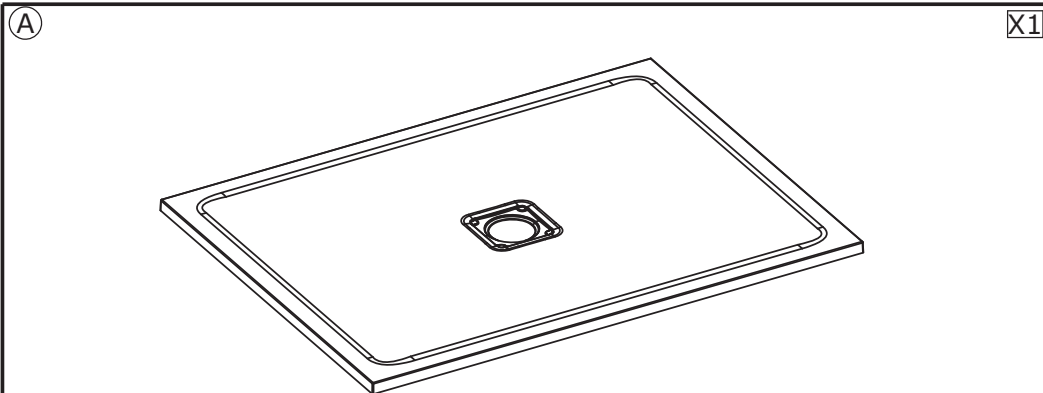

	100x70	REC640	120x70	REC643	140x70	REC647	160x80	REC650			
90x75	REC638	100x80	REC641	120x80	REC644	140x80	REC648	160x90	REC651	180x80	REC653
90x90	REC639	100x90	REC642	120x90	REC645	140x90	REC649	170x70	REC652	180x90	REC654

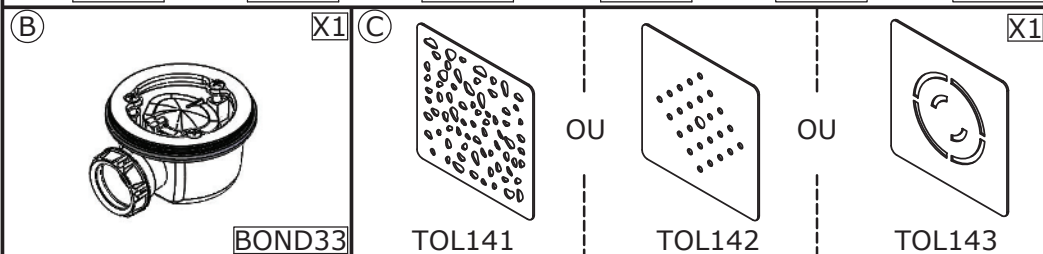

- Les quantités données sont les quantités utiles au montage. les sachets fournis contiennent des pièces supplémentaires.
- The quantities given are what are required for the installation. There may be some surplus in the package provide.
- Las cantidades indicadas son las cantidades necesarias para el montaje. Las bolsitas incluidas contienen piezas suplementarias.
- Le quantità fornite sono le quantità necessarie al montaggio. I sacchetti forniti contengono pezzi supplementari.
- De aangegeven aantallen zijn bestemd voor de montage. De bijgeleverde zakjes bevatten extra onderdelen
- Die Mengenangaben beziehen sich auf die für die Montage benötigten Teile. Es kann eine gewisse Überzahl an Teilen in der Packung vorhanden sein.



- "Le montage de ce receveur avec une autre bonde que celle fournie annule la garantie, sauf KINEFLOOR, BOND19 et BOND25 de notre catalogue"
- "Mounting this receiver with a bung other than the one provided voids the warranty, except for KINEFLOOR, BOND19 and BOND25 in our catalogue"
- "El montaje de este plato de ducha con un tapón distinto al suministrado anula la garantía, excepto para KINEFLOOR, BOND19 y BOND25 en nuestro catálogo".
- "Il montaggio di questo ricevitore con un tappo diverso da quello fornito invalida la garanzia, ad eccezione di KINEFLOOR, BOND19 e BOND25 nel nostro catalogo".
- "Deze douchebak monteren met een andere dan meegeleverde sifon doet de garantie vervallen, met uitzondering van de KINEFLOOR, BOND19 en BOND25 uit onze catalogus".
- "Die Montage der Duschtasse mit einer anderen Ablaufgarnitur als der werksseitig vorgesehenen führt zum Erlöschen der Garantie. Ausgenommen hiervon sind die Abläufe: KINEFLOOR, BON19 und BOND25 aus unserem Katalog".

**F** Matériel nécessaire **GB** Tools required **E** Material necesario  
**I** Materiale necessario **NL** Benodigdheden **D** Erforderliche Werkzeuge

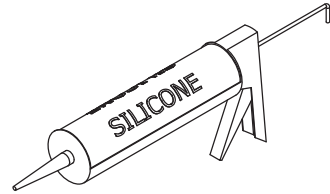
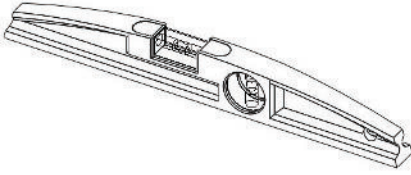

- F** Colle polyuréthane ou MS polymère
- GB** Polyurethane adhesive or MS polymer
- E** Pegamento poliuretano o polímero MS
- I** Colla poliuretanică o MS polimer
- NL** Plyurethaan of MS-polymeer lijm
- D** Polyurethan oder MS-Polymere Montagekleber verwenden

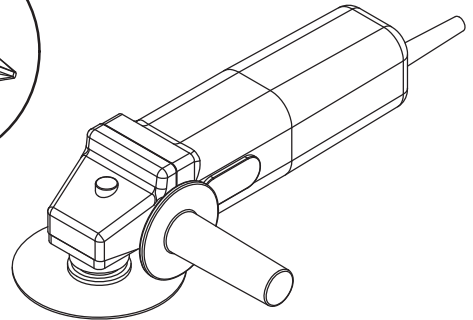
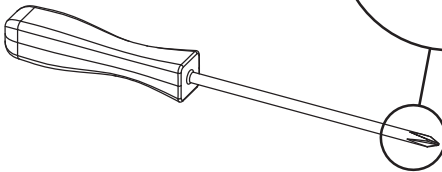
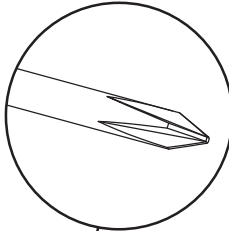
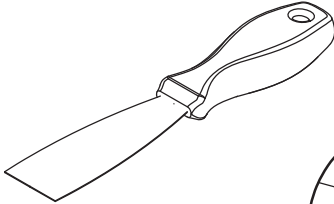

- F** Meuleuse avec lame diamant Ø230mm min.
- GB** Grinder with diamond blade Ø230mm min.
- E** Pulidora con disco diamantado Ø230mm min.
- I** Mola con lama diamantata Ø230mm min.
- NL** Flexmachine met diamanten slijpsteen Ø230mm min.
- D** Winkelschleifer mit Diamanttrennscheibe Ø230mm min.



- F DECOUPE OPTIONNELLE DU RECEVEUR
- GB ZONE AVAILABLE FOR OPTIONAL RECUTTING
- E RECORTE OPCIONAL
- I TAGLIO OPZIONALE DEL PIATTO
- NL BIJSNIJDEN VAN DE DOUCHEBAK, OPTINEEL
- D OPTIONALE SCHNEIDBEREICHE DER DUSCHWANNE

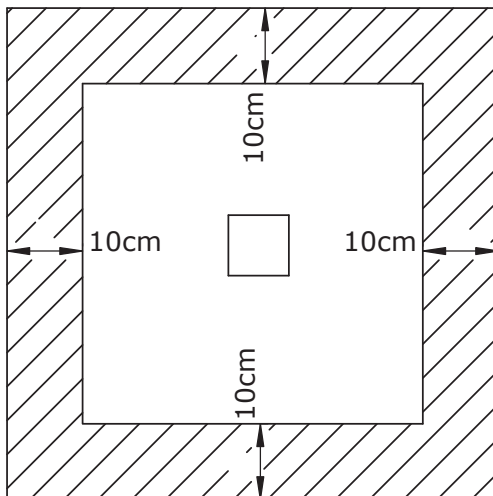
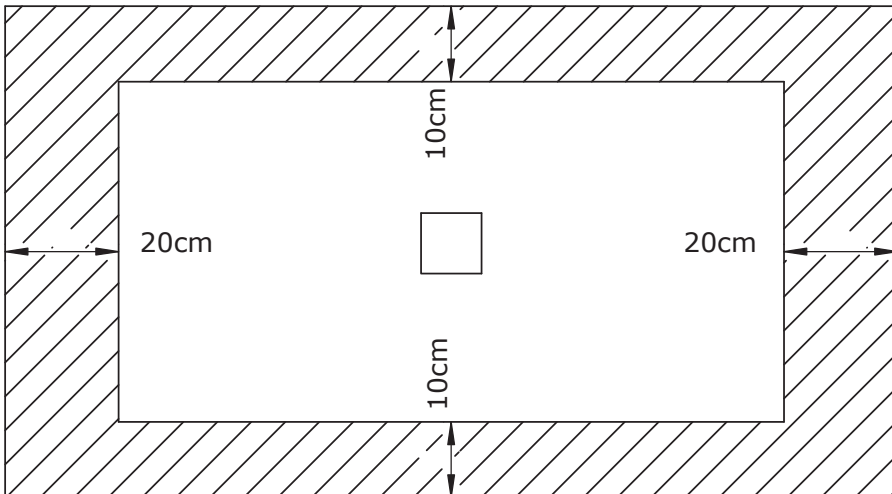

- F Zone MAXI découpable
- D MAX cuttable area
- E Zone MAXIMA de recorte
- I Limite MASSIMO di taglio
- NL MAXIMAAL aanpasbaar deel
- D MAXIMALER Schneidbereich

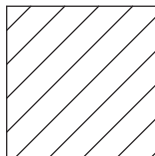

1

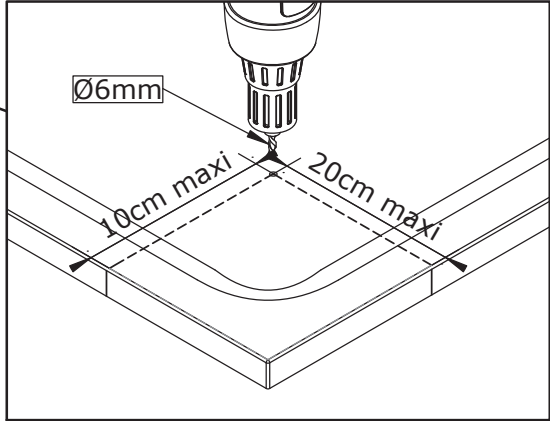
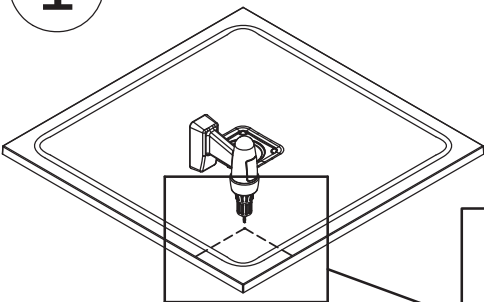

2

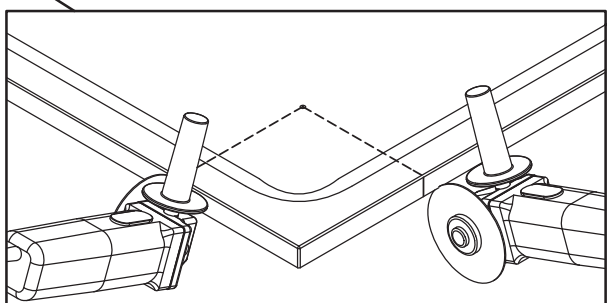
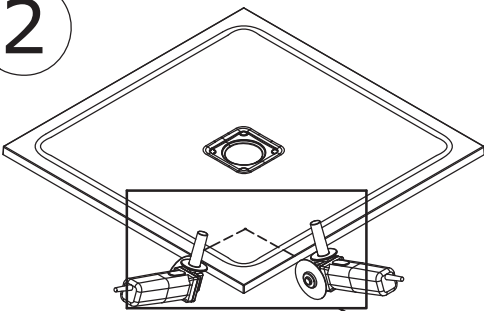

3



Ⓕ - Appliquer une couche de colle polyuréthane ou MS polymère à l'aide d'une spatule sur la surface coupée et combler l'espace entre les nervures du receveur avec une couche de mortier adhésif.

ⒼⒷ - Apply a polyurethan adhesive or MS polymer layer using a spatula over the raw surface and fill the space between the ribs of the tray with a layer of adhesive mortar.

Ⓔ - Aplicar una capa de pegamento poliuretano o polímero MS en la superficie recortada. Puede ayudarse de una espátula y rellenar los espacios huecos del plato con una capa de mortero adhesivo.

Ⓘ - Applicare della colla poliuretanoica o MS polimero con l'aiuto di una spatola sulla parte tagliato e compensare lo spazio tra le venature del piatto con uno strato di materiale adesivo.

Ⓝ - Breng met een spatel een laag polyurethaan lijm of MS polymeer lijm aan op de zaagranden, en vul de tussenliggende ruimte met het steunoppervlak van de douchebak op met een laag cement.

Ⓓ - Wenn Sie ihre Duschtasse zuschneiden, müssen die Schnittkanten mittels Polyurethan- oder MS-Polymer-Klebstoff versiegelt werden. Tragen Sie die Versiegelung mit einem Spachtel auf der Schnittfläche bis unterhalb der Duschtasse auf.

- Ⓕ Colle polyuréthane/MS polymère
- ⒼⒷ Polyurethane adhesive/MS polymer
- Ⓔ Pegamento poliuretano/polimero MS
- Ⓘ Colla poliuretanoica/MS polimero
- Ⓝ Polyurethaan/MS polymeer lijm
- Ⓓ Schicht aus Polyurethan-/MS-Polymer-Klebstoff

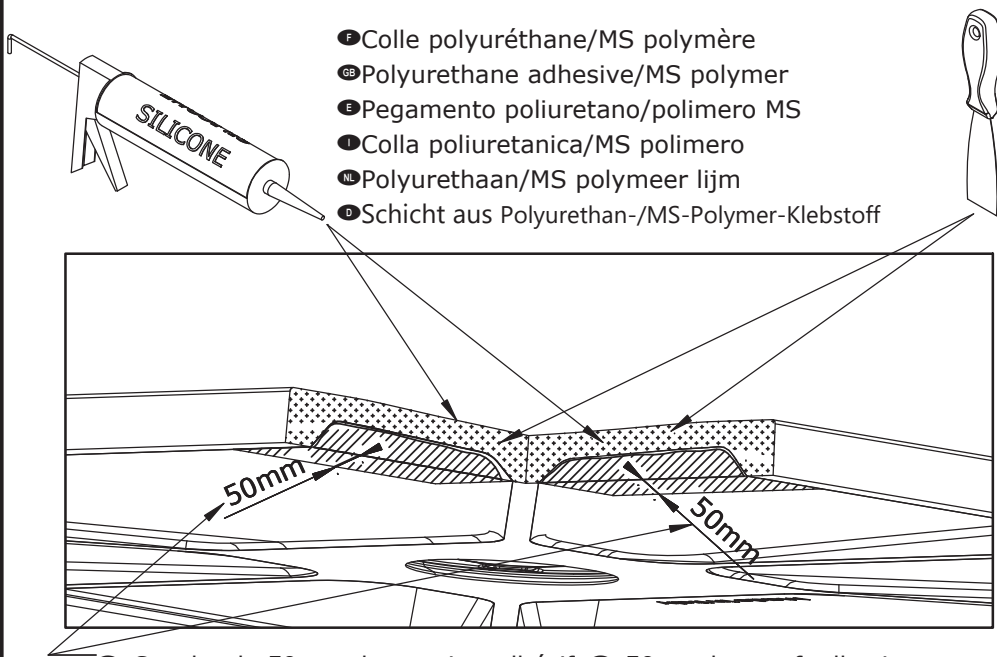

- Ⓕ Couche de 50mm de mortier adhésif ⒼⒷ 50mm layer of adhesive mortar
- Ⓔ Capa de 50mm de grosor de mortero adhesivo
- Ⓘ Strato di 50mm di materiale adesivo
- Ⓝ Laag van 50mm cement Ⓓ 50 mm Versiegelung auftragen

- F Nombre de pieds GB Feet quantity E Cantidad de pies  
 I Quantità di piedini NL Hoeveelheid voeten D Anzahl an FüÙe

90x75	4	90x90	4		
100x70	4	100x80	4	100x90	4
120x70	8	120x80	8	120x90	8
140x70	10	140x80	10	140x90	10
160x80	10	160x90	10		
170x70	10				
180x80	12	180x80	12		

F La distance bord à bord entre deux pieds ne doit pas être de plus de 30 cm.  
 LES PIEDS DOIVENT ETRE INSTALLES SUR LES NERVURES DU RECEVEUR.

GB The distance from the edge of the shower tray to the edge of a peripheral support  
 should be no more than 30 cm.  
 THE FEET MUST BE INSTALLED ON THE SHOWER TRAY RIBS.

E La distancia entre cada pie no debe superar los 30 cm.  
 LOS PIES DEBEN ESTAR INSTALADOS SIGUIENDO LAS NERVIOS DEL PLATO.

I La distanza tra due piedi non dovrebbe essere superiore a 30 cm.  
 I PIEDI DEVONO ESSERE INSTALLATI SULLE NERVATURE DEL PIATTO DOCCIA.

NL De afstand tussen twee stelpoten mag niet meer dan 30 cm bedragen.  
 DE STELPOTEN DIENEN OP HET STEUNOPPERVLAK VAN DE DOUCHEBAK GEÏNSTALLEERD  
 TE WORDEN.

D Der Abstand zwischen zwei verstellbaren FüÙen darf 30 cm nicht überschreiten.  
 DIE FÜÙE MÜSSEN AUF DEN TRÄGERN DER DUSCHTASSE MONTIERT WERDEN.

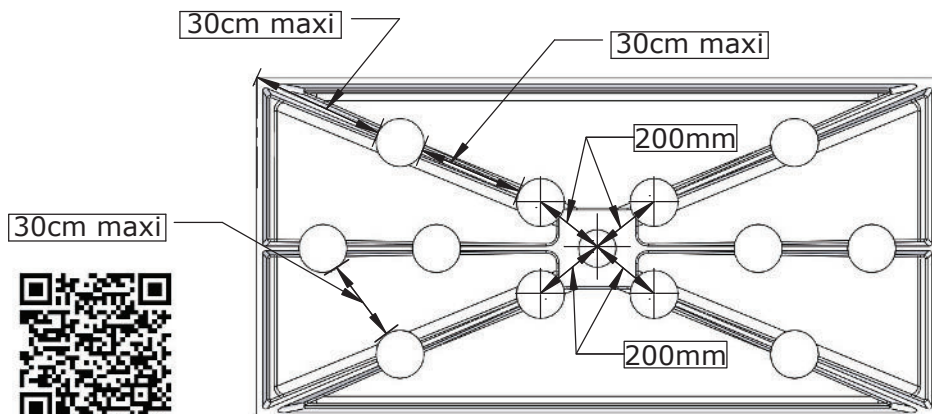

Scan me

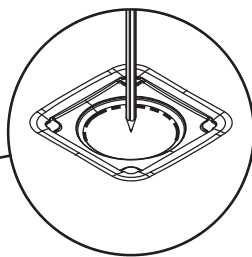
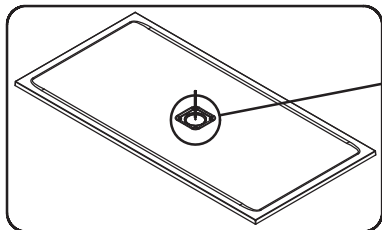
**F**

Tracer la position de la bonde et réaliser un montage à blanc de la bonde et du receveur

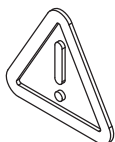
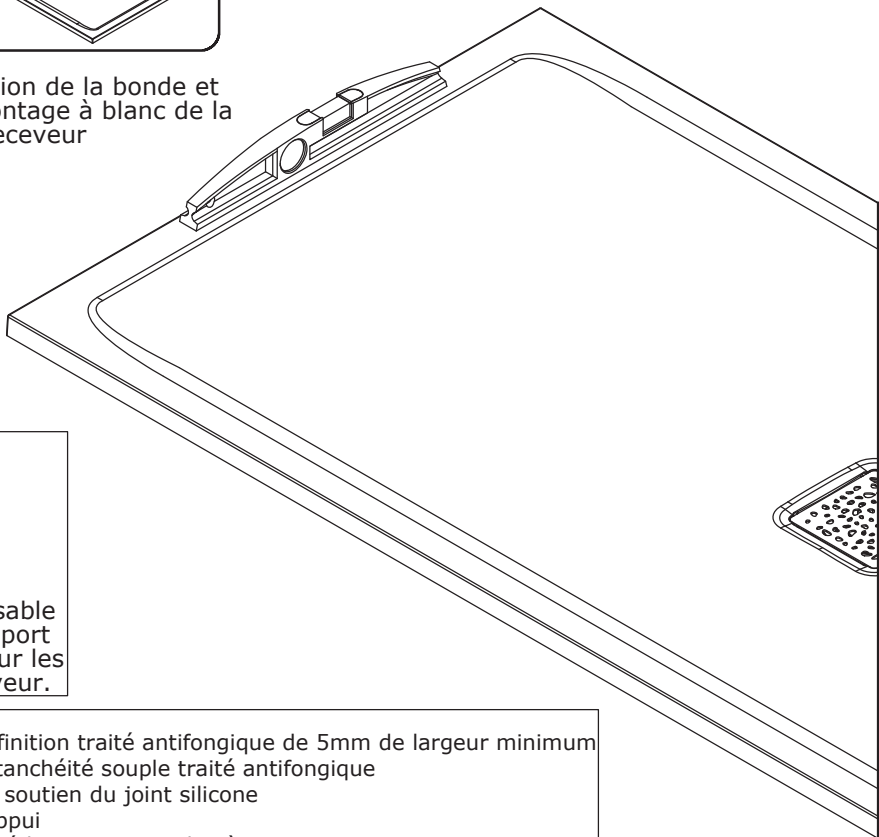

Il est indispensable d'avoir un support imputrescible sur les côtés du receveur.

- ① - silicone de finition traité antifongique de 5mm de largeur minimum
- ② - silicone d'étanchéité souple traité antifongique
- ③ - élément de soutien du joint silicone
- ④ - silicone d'appui
- ⑤ - colle polyuréthane ou MS polymère

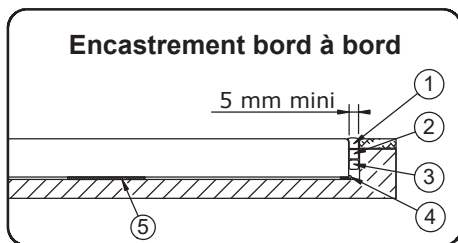
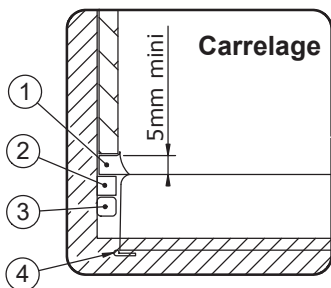





Pendant toute la durée des travaux, protéger le receveur contre toute agression : brûlures, chocs, rayures, décapants...



Le montage d'une soupape anti-vide est nécessaire pour une utilisation optimale si un autre appareil sanitaire est raccordé sur la même évacuation.

Ne pas utiliser d'acide chlorhydrique ni de dégraissant puissant

### Pose directe au sol

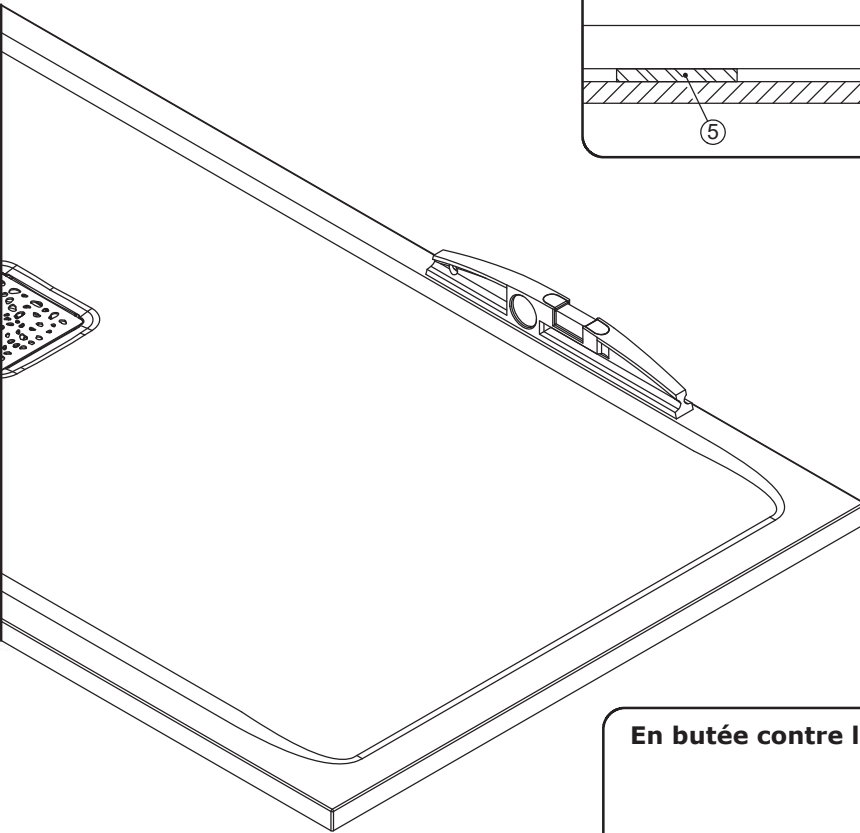
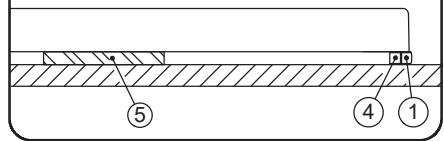

### En butée contre le carrelage

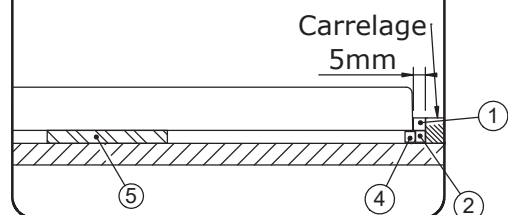

Sol rigide, plan et non humide indispensable

X	Y	C	D
90	90	32,5	32,5
90	75	25	32,5
100	70	22,5	37,5
100	80	27,5	37,5
100	90	32,5	37,5
120	70	22,5	47,5
120	80	27,5	47,5
120	90	32,5	47,5
140	70	22,5	57,5
140	80	27,5	57,5
140	90	32,5	57,5
160	80	27,5	67,5
160	90	32,5	67,5
170	70	22,5	72,5
180	80	27,5	77,5
180	90	32,5	77,5

# KINEMOON

## TYPES D'INSTALLATION POUR TOUS MODÈLES

### 1. Posé sur pieds réglables avec habillage carrelé

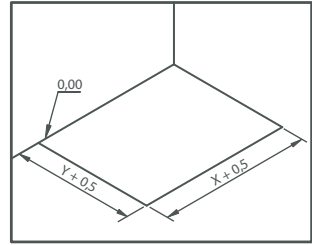
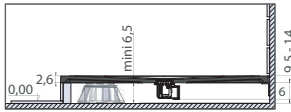
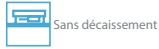
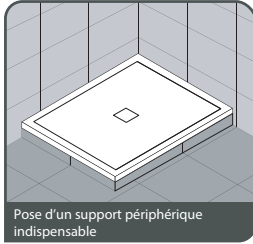

Préparation de l'implantation

### 2. Posé en butée contre le carrelage

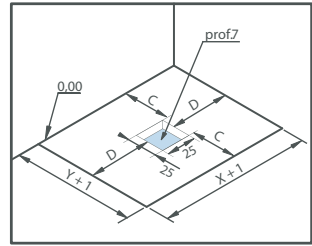
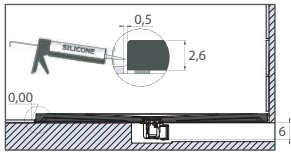
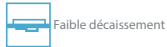
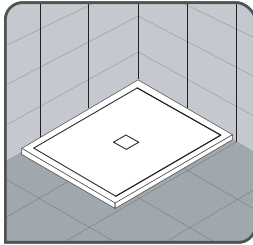

Préparation de l'implantation

### 3. Encastré et posé sur pieds réglables

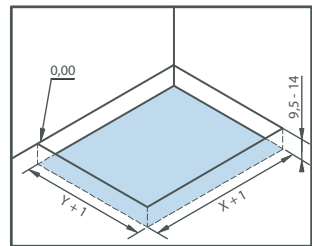
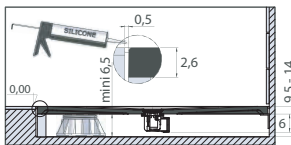
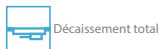
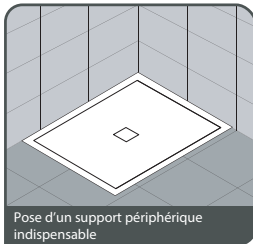

Préparation de l'implantation

### 4. Encastré et posé sans pieds réglables

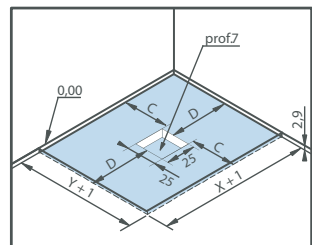
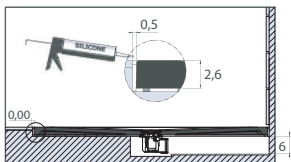
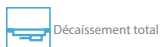
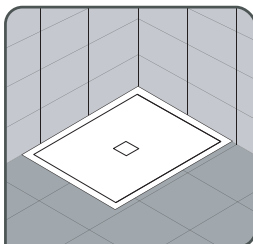

Préparation de l'implantation

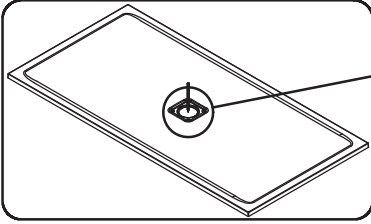

Mark the position of the waste and test-  
assemble the tray and waste

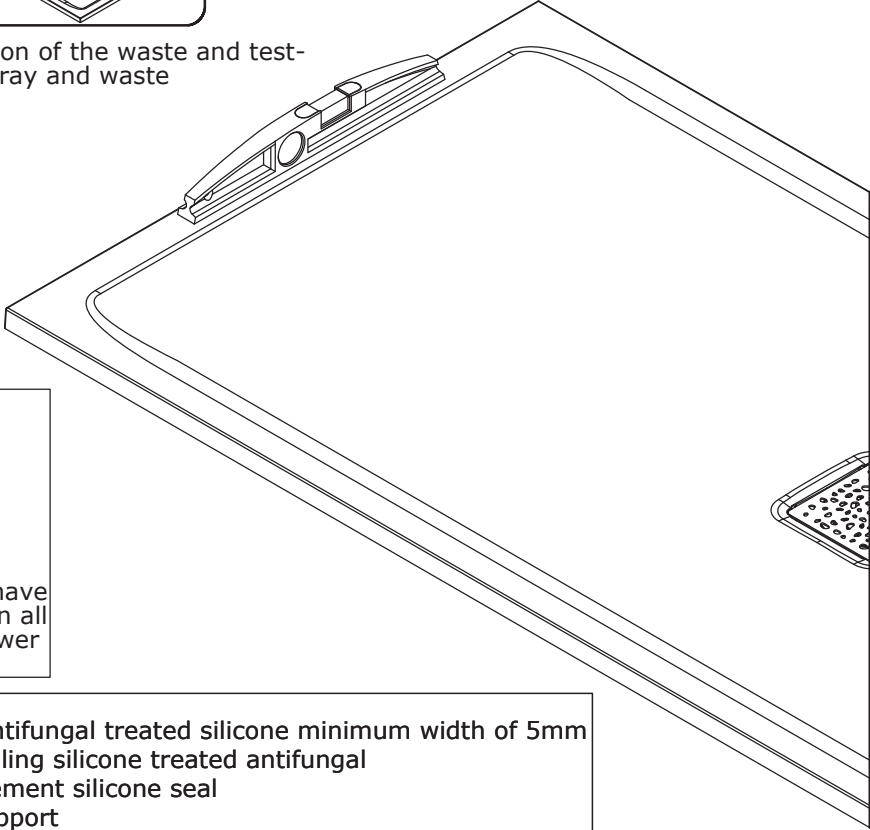

- ① - finishing antifungal treated silicone minimum width of 5mm
- ② - flexible sealing silicone treated antifungal
- ③ - support Element silicone seal
- ④ - silicone Support
- ⑤ - polyurethane adhesive or MS polymer

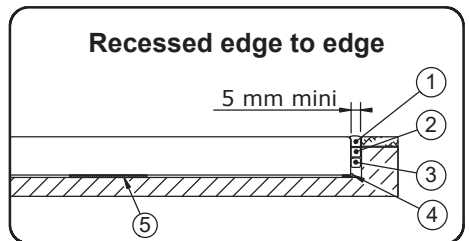
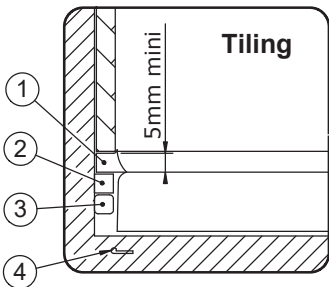



Throughout the protect the tray of the work, protect the recipient against any aggression: burns, shock, scratches, strippers ...



Mounting a vacuum relief valve is required for use optimal if another fixture is connected to the same drain.

Do not use hydrochloric acid or powerful degreaser

### Direct floor installation

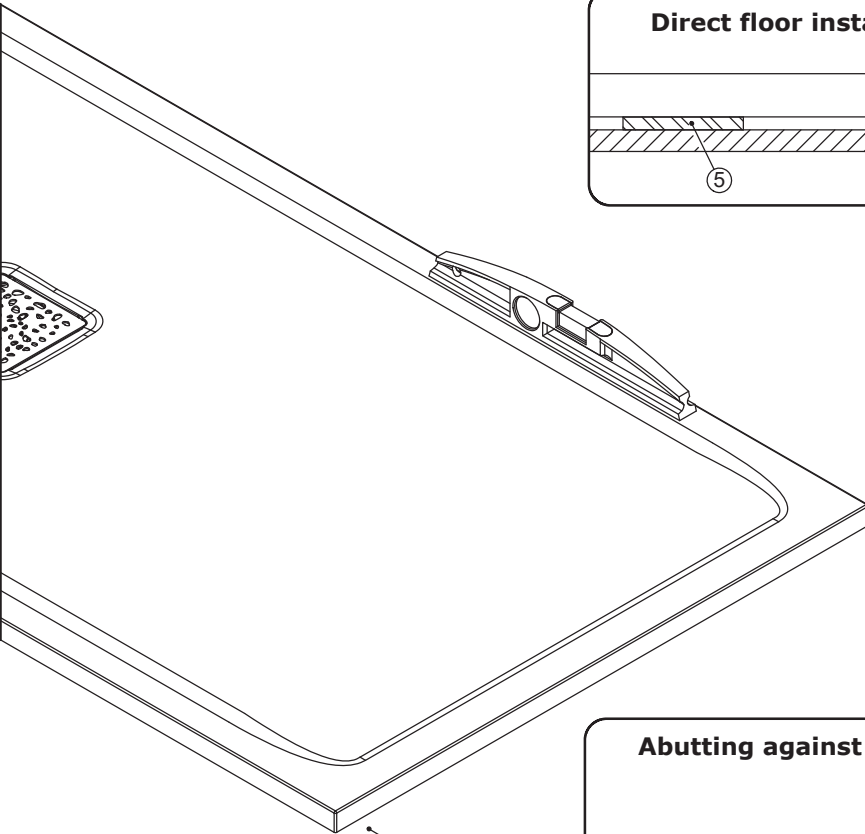
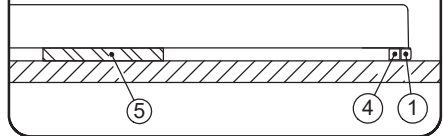

### Abutting against the tile

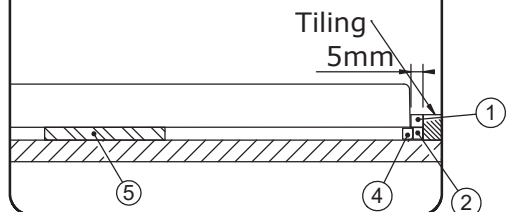

The base must be rigid, flat and dry

X	Y	C	D
90	90	32,5	32,5
90	75	25	32,5
100	70	22,5	37,5
100	80	27,5	37,5
100	90	32,5	37,5
120	70	22,5	47,5
120	80	27,5	47,5
120	90	32,5	47,5
140	70	22,5	57,5
140	80	27,5	57,5
140	90	32,5	57,5
160	80	27,5	67,5
160	90	32,5	67,5
170	70	22,5	72,5
180	80	27,5	77,5
180	90	32,5	77,5

# KINEMOON

## KINEMOON INSTALLATION TYPES

### 1. Mounted on adjustable legs with tiled cladding

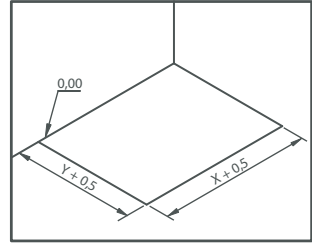
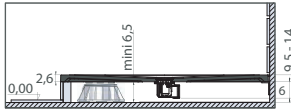
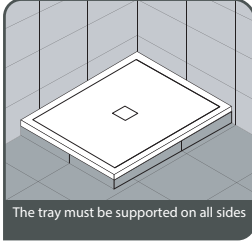

### 2. Installed in abutment against the tile

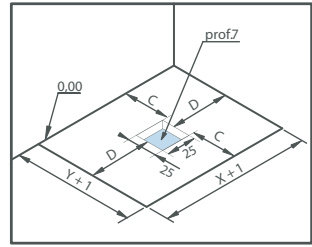
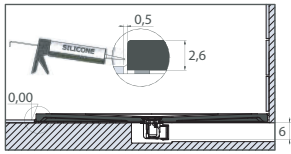
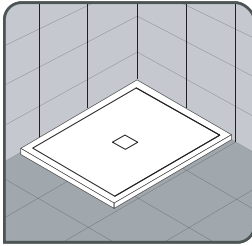

### 3. Built-in and placed on adjustable legs

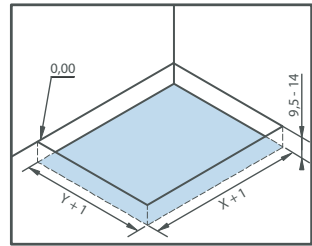
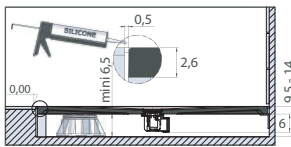
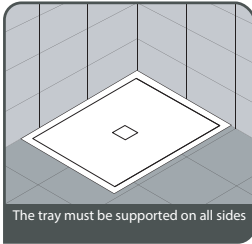

### 4. Built-in and installed without adjustable feet

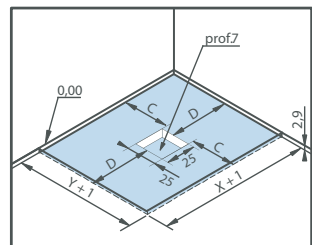
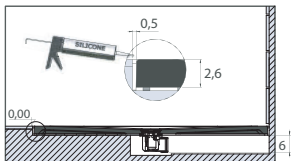
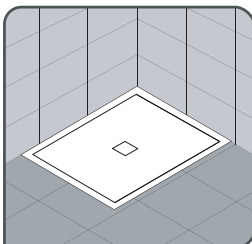

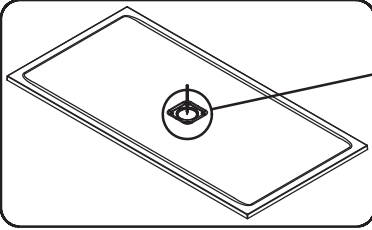
**E**

Marcar la ubicación del desagüe y montarlo con el plato para comprobar su correcta ubicación.

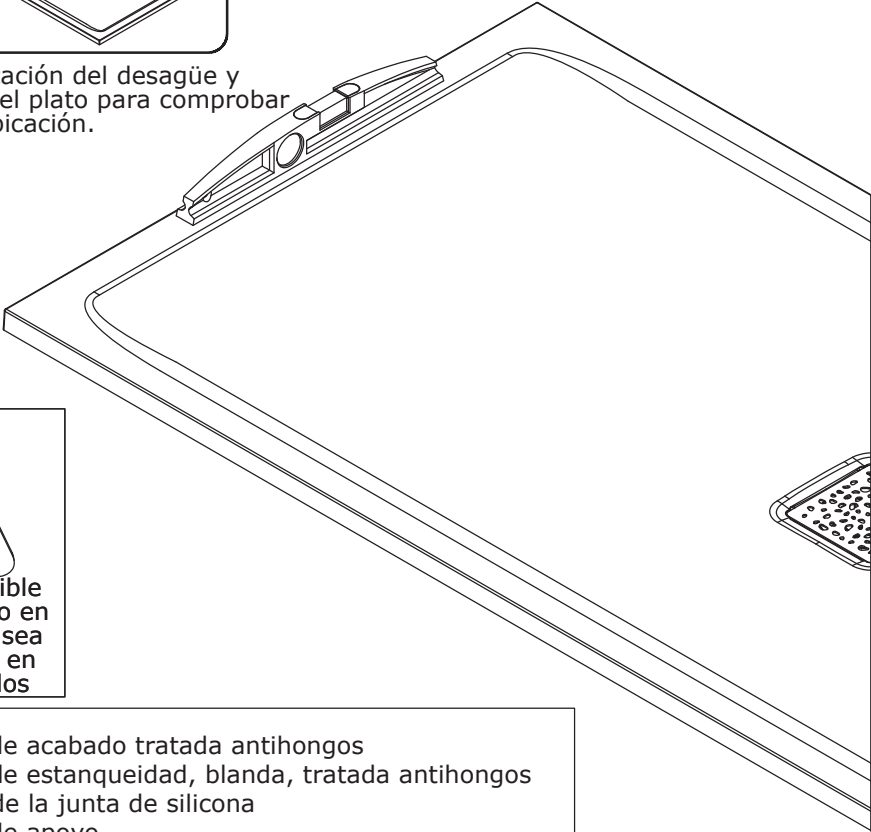

Es imprescindible instalar el plato en una zona que sea imputrescible en todos sus lados

- ① - silicona de acabado tratada antihongos
- ② - silicona de estanqueidad, blanda, tratada antihongos
- ③ - soporte de la junta de silicona
- ④ - silicona de apoyo
- ⑤ - pegamento poliuretano o polímero MS

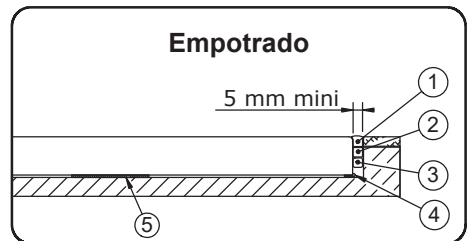
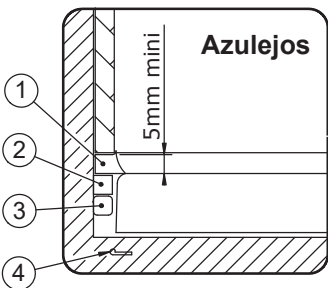





Durante las obras proteger el plato de golpes, quemaduras, rayaduras, etc.



La instalación de un venteo es necesaria si otro aparato está conectado al mismo recorrido de evacuación.

No utilizar ácido clorhídrico o desengrasante potente

### Instalación directa al suelo

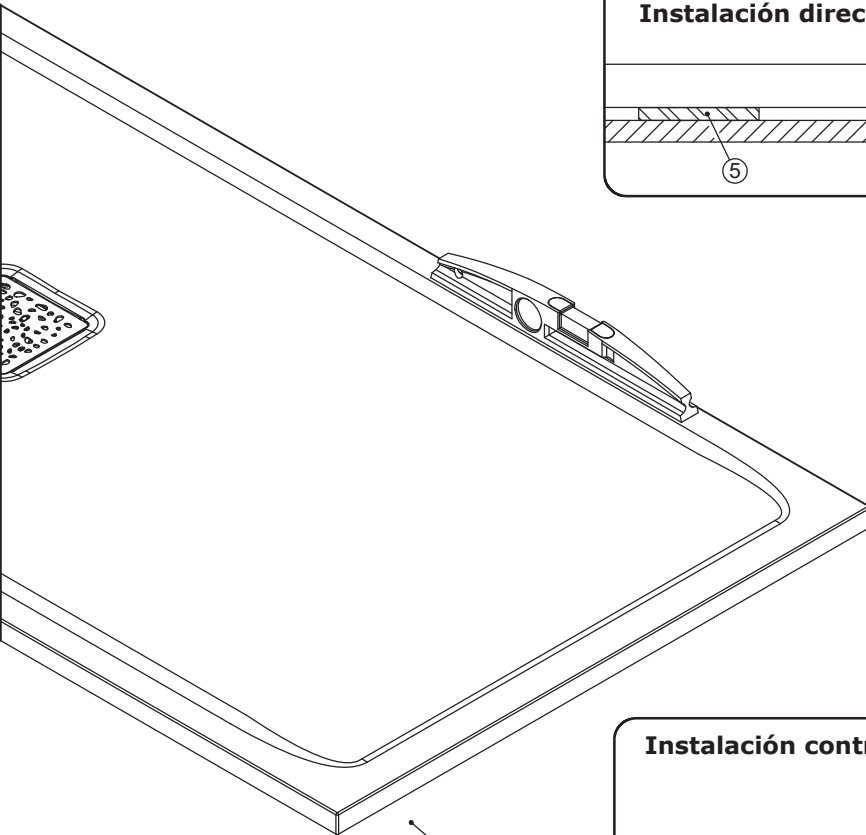
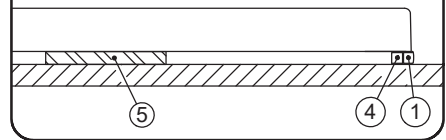

Suelo rígido, plano y seco indispensable

### Instalación contra baldosas

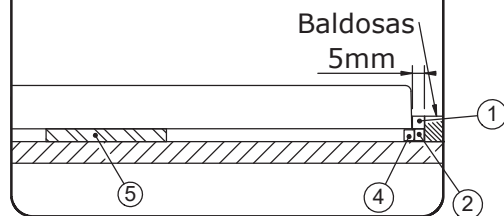

X	Y	C	D
90	90	32,5	32,5
90	75	25	32,5
100	70	22,5	37,5
100	80	27,5	37,5
100	90	32,5	37,5
120	70	22,5	47,5
120	80	27,5	47,5
120	90	32,5	47,5
140	70	22,5	57,5
140	80	27,5	57,5
140	90	32,5	57,5
160	80	27,5	67,5
160	90	32,5	67,5
170	70	22,5	72,5
180	80	27,5	77,5
180	90	32,5	77,5

# KINEMOON

## TIPOS DE INSTALACIÓN KINEMOON

### 1. Instalado sobre pies ajustables con revestimiento de baldosas

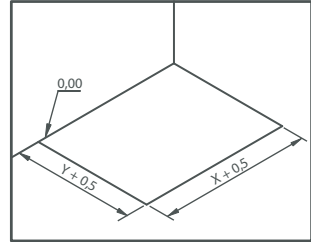
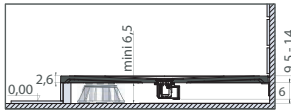

Preparación de la instalación

### 2. Colocación sobre suelo

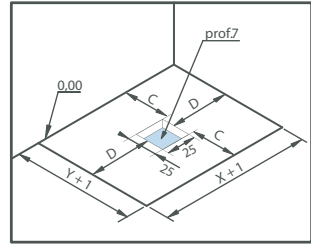
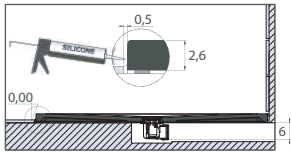
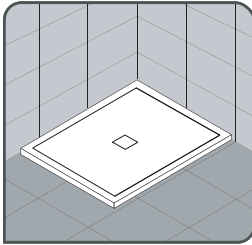

Preparación de la instalación

### 3. Instalación a ras de suelo, colocado sobre pies ajustables

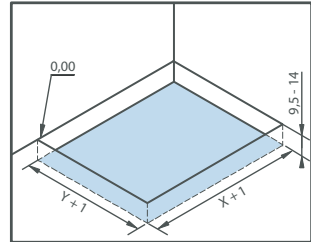
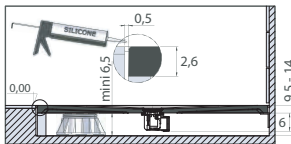

Preparación de la instalación

### 4. Instalación a ras de suelo, sin pies ajustables

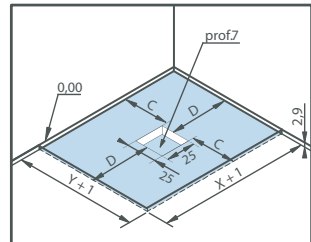
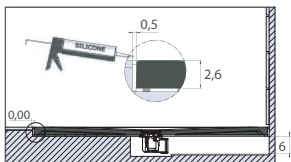
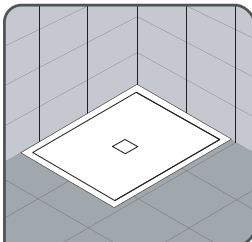

Preparación de la instalación

I

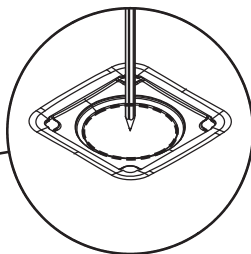
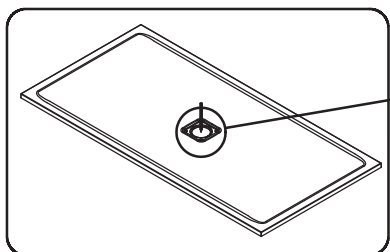

Tracciare la posizione dello scarico e realizzare un montaggio a vuoto dello scarico e del piatto

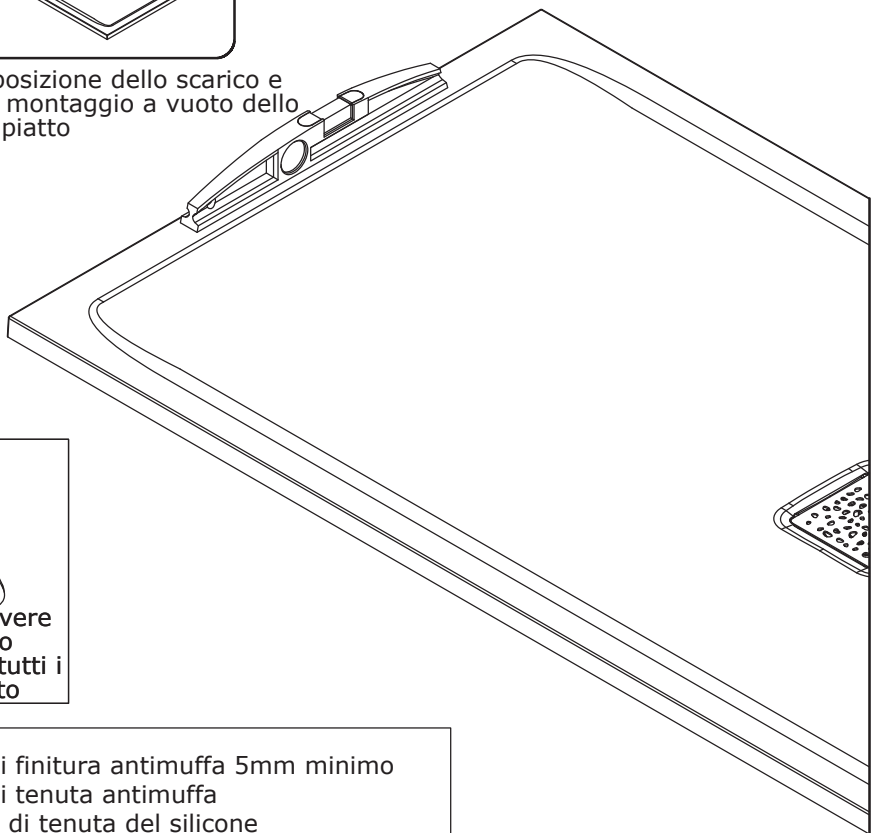

- ① - silicone di finitura antimuffa 5mm minimo
- ② - silicone di tenuta antimuffa
- ③ - elemento di tenuta del silicone
- ④ - supporte in silicone
- ⑤ - colla poliuretanica o MS polimero

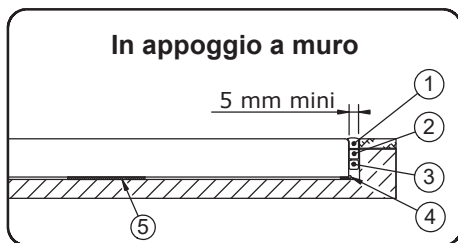
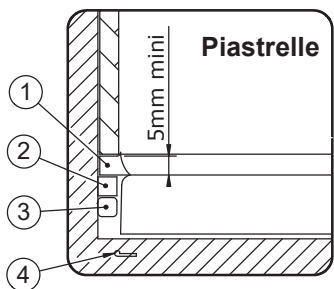



Durante la posa proteggere il piatto da graffi, colpi, attrezzi, bruciature



Il montaggio di una valvola di sicurezza è richiesto per un uso ottimale se un altre utenezono collegate allo stesso scarico.

Non utilizzare acido cloridrico o forti sgrassatori

### Posa diretta al suolo

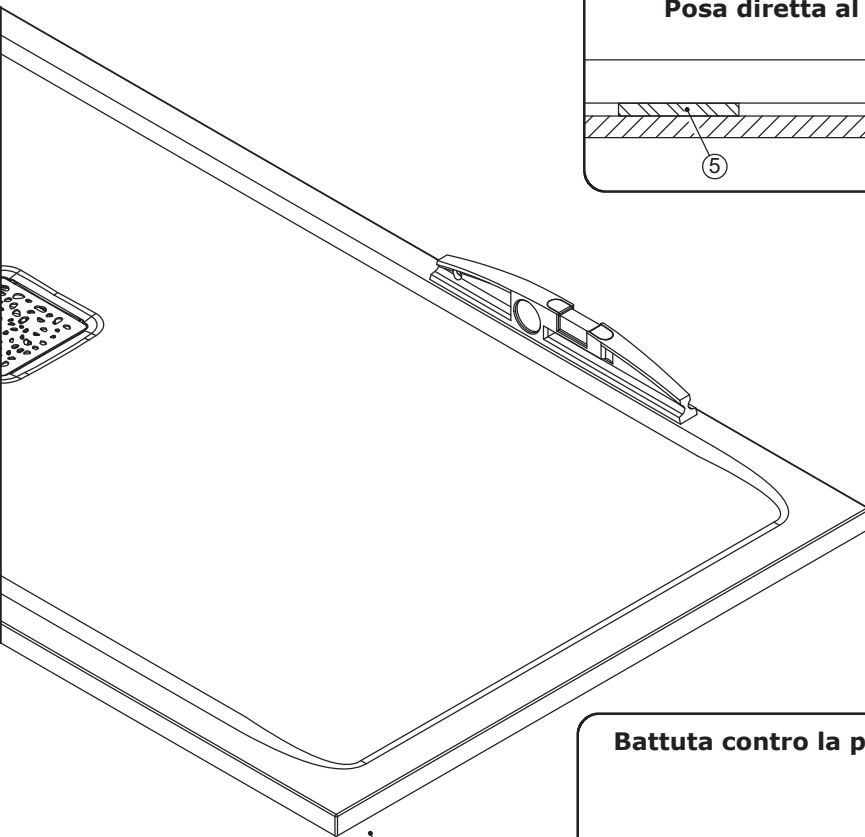
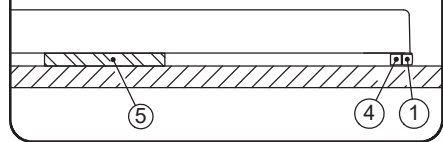

Suolo robusto e non umido

### Battuta contro la piastrella

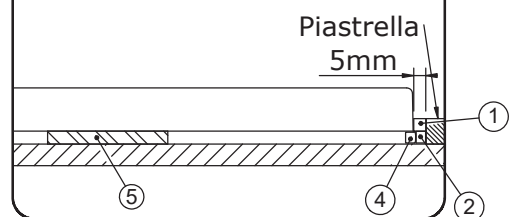

X	Y	C	D
90	90	32,5	32,5
90	75	25	32,5
100	70	22,5	37,5
100	80	27,5	37,5
100	90	32,5	37,5
120	70	22,5	47,5
120	80	27,5	47,5
120	90	32,5	47,5
140	70	22,5	57,5
140	80	27,5	57,5
140	90	32,5	57,5
160	80	27,5	67,5
160	90	32,5	67,5
170	70	22,5	72,5
180	80	27,5	77,5
180	90	32,5	77,5

# KINEMOON

## TIPI DI INSTALLAZIONE DI KINEMOON

### 1. Montato su piedini regolabili con rivestimento in piastrelle

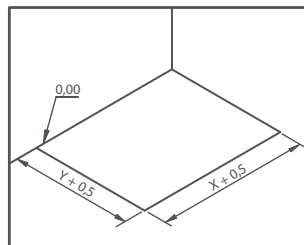

Predisposizione impianto

### 2. Installato in appoggio a pavimento

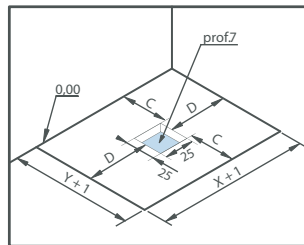
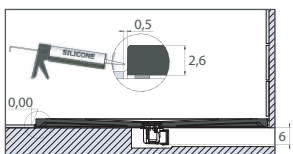
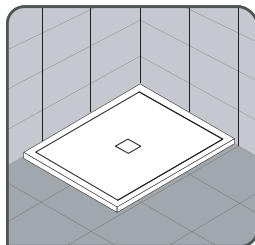

Predisposizione impianto

### 3. Incassato e posizionato su piedini regolabili

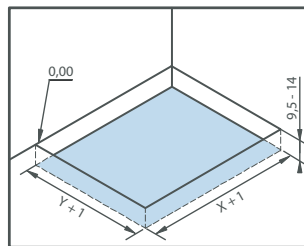
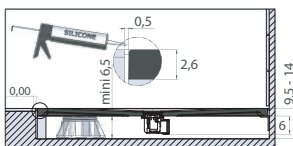

Predisposizione impianto

### 4. Installato a filo pavimento

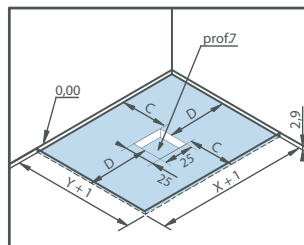
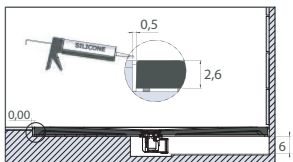
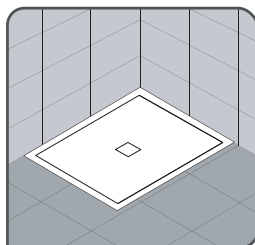

Predisposizione impianto

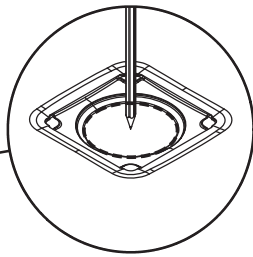
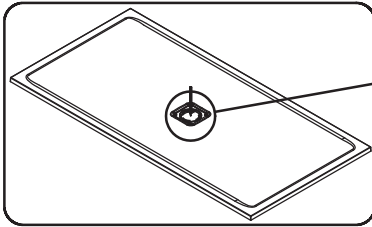

Markeer de positie van de afvoer en  
situeer de afvoer en de douchebak op  
de gewenste plaats

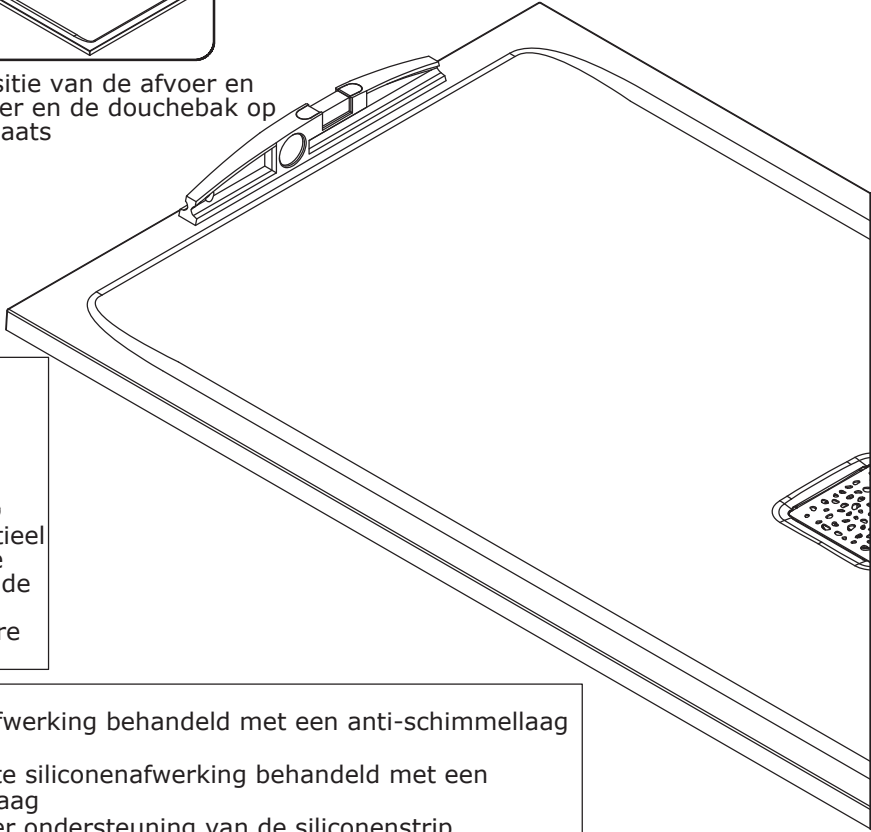

Het is van essentieel  
belang dat de  
douchebak aan de  
zijanten een  
ondoordringbare  
steun heeft.

- ① - siliconenafwerking behandeld met een anti-schimmellaag van 5 mm min
- ② - waterdichte siliconenafwerking behandeld met een anti-schimmellaag
- ③ - element ter ondersteuning van de siliconenstrip
- ④ - aanbrengen van siliconenkit
- ⑤ - polyuretaan lijm of MS polymeer

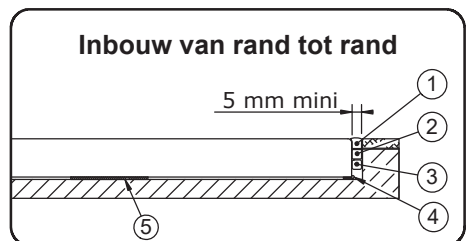
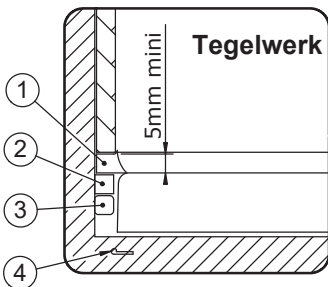





Bescherm de douchebak tijdens de werkzaamheden tegen brandplekken, schokken en beschadigingen door krassen etc



De Montage van een afdichtingsklep/ventiel is noodzakelijk voor optimaal gebruik indien men een ander sanitair product wil aansluiten op dezelfde afvoer.

Geen chloorhoudende producten en ontvetters gebruiken!

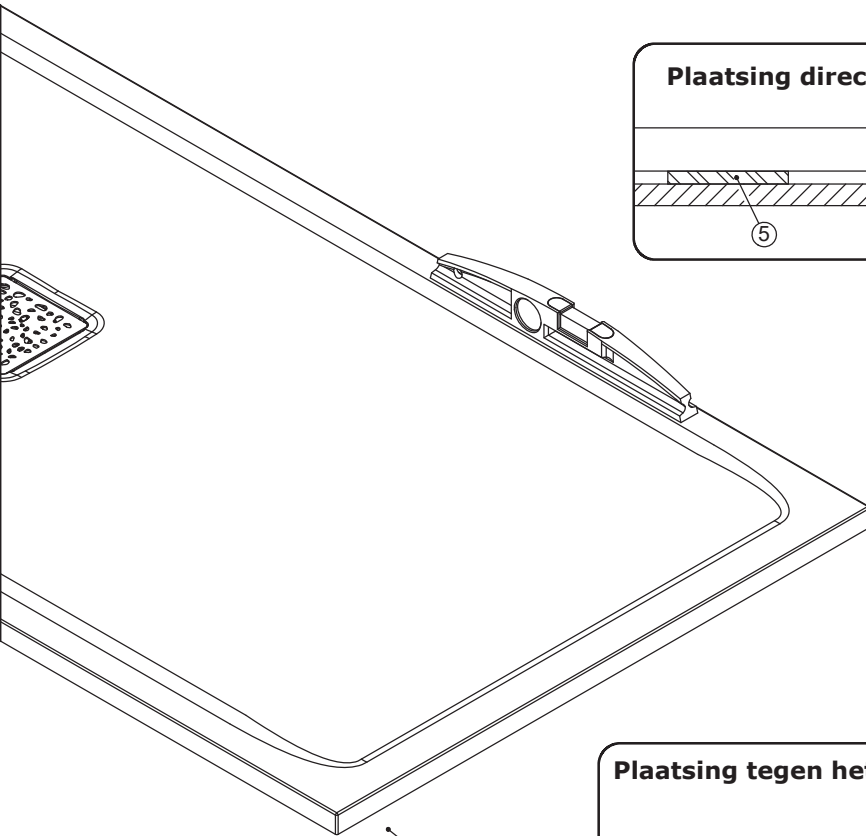

#### Plaatsing direct op de vloer

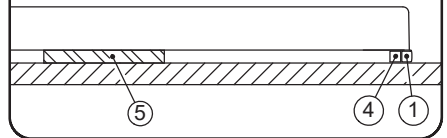

#### Plaatsing tegen het tegelwerk

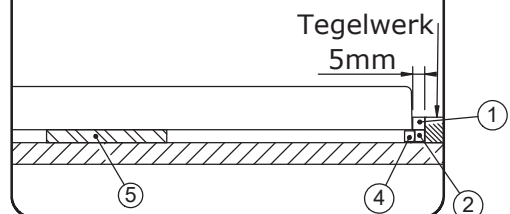

Vlakte niet-vochtige vloer is essentieel

X	Y	C	D
90	90	32,5	32,5
90	75	25	32,5
100	70	22,5	37,5
100	80	27,5	37,5
100	90	32,5	37,5
120	70	22,5	47,5
120	80	27,5	47,5
120	90	32,5	47,5
140	70	22,5	57,5
140	80	27,5	57,5
140	90	32,5	57,5
160	80	27,5	67,5
160	90	32,5	67,5
170	70	22,5	72,5
180	80	27,5	77,5
180	90	32,5	77,5

# KINEMOON

## KINEMOON-INSTALLATIEMOGELIJKHEDEN

### 1. Geïnstalleerd op in hoogte verstelbare poten en afgewerkt met tegels

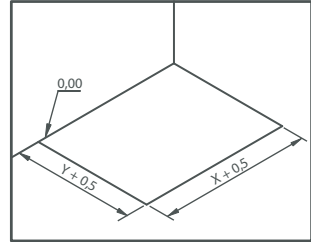
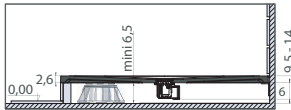

Vorbereitung montage

### 2. Geïnstalleerd half verzonken tegen de tegels

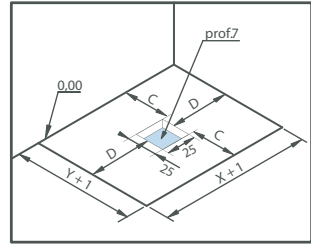
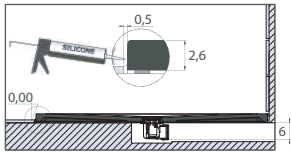
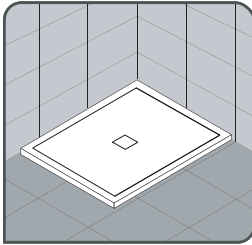

Vorbereitung montage

### 3. Ingebouwd met in hoogte verstelbare poten

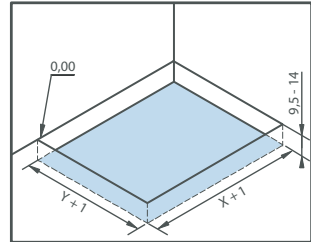
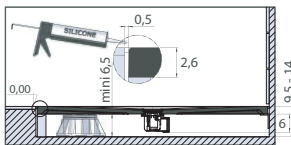

Vorbereitung montage

### 4. Ingebouwd zonder in hoogte verstelbare poten

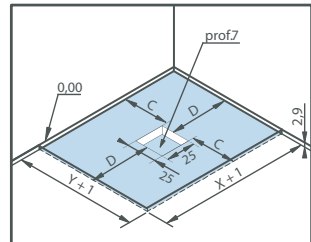
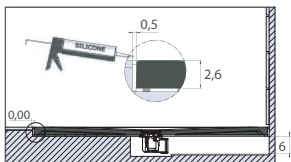
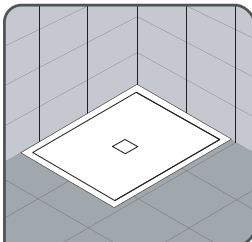

Vorbereitung montage

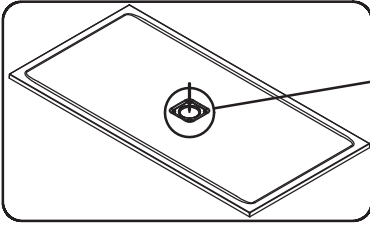
**D**

Position für den Ablauf anzeichnen  
und vormontieren.

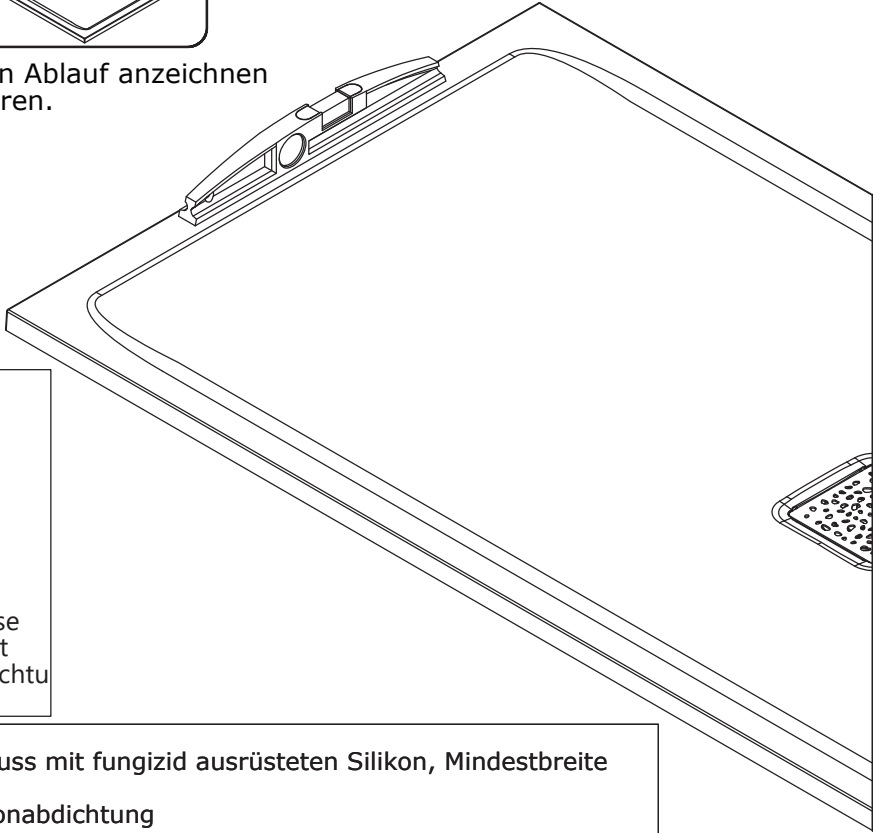

- ① - Fugenabschluss mit fungizid ausgerüsteten Silikon, Mindestbreite von 5 mm
- ② - flexible Silikonabdichtung
- ③ - Träger Element/Unterbau Silikonichtung
- ④ - Silikonträger
- ⑤ - Polyurethan-Klebstoff oder MS-Polymer

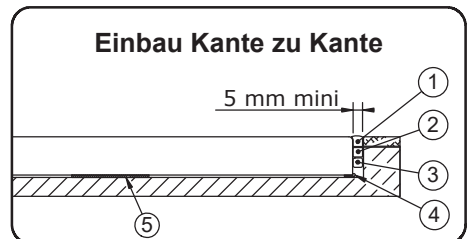
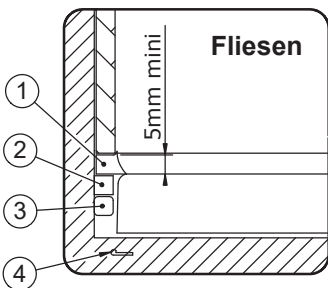



Montage eines Unterdruckventils wird benötigt, wenn eine andere Vorrichtung an den gleichen Ablauf angeschlossen ist.

Während den Installationsarbeiten auf ausreichenden Schutz gegen aggressive Mittel achten: Verbrennungen, Stöße, Kratzer oder Abbeizmittel ...

Verwenden Sie keine säurehaltigen oder andere aggressive Entfetter.

freie Aufstellung auf  
Fertigfußboden

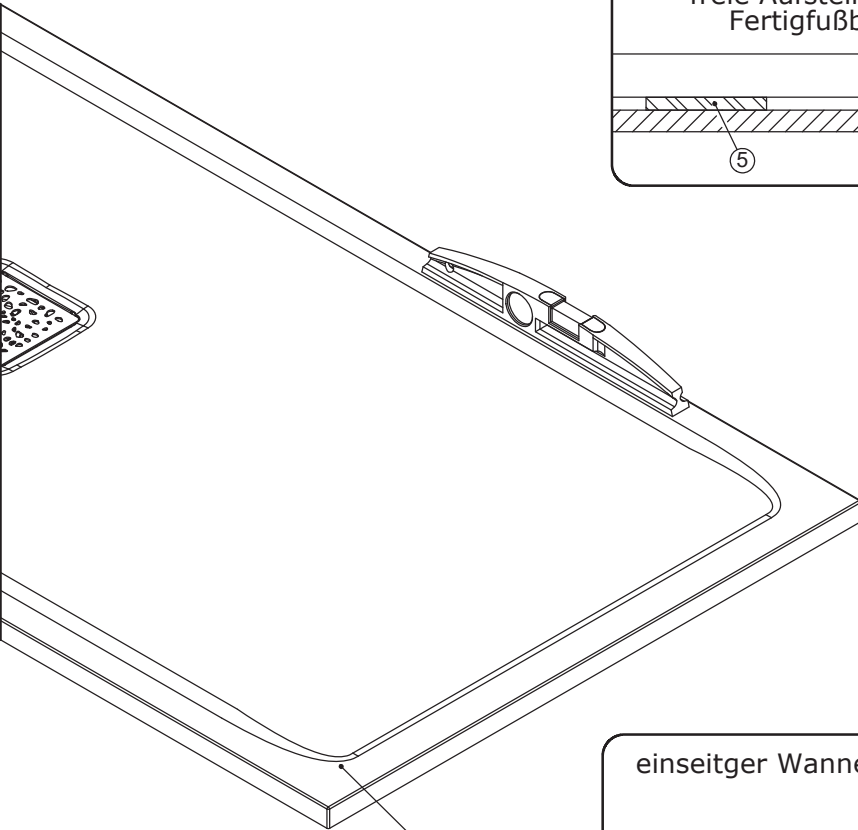
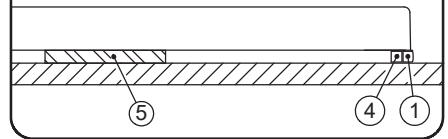

einseitiger Wannenanschluß

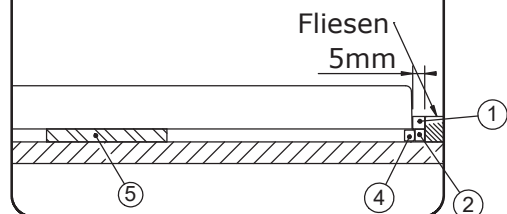

Auf festen, planen und nicht feuchten Boden achten.

X	Y	C	D
90	90	32,5	32,5
90	75	25	32,5
100	70	22,5	37,5
100	80	27,5	37,5
100	90	32,5	37,5
120	70	22,5	47,5
120	80	27,5	47,5
120	90	32,5	47,5
140	70	22,5	57,5
140	80	27,5	57,5
140	90	32,5	57,5
160	80	27,5	67,5
160	90	32,5	67,5
170	70	22,5	72,5
180	80	27,5	77,5
180	90	32,5	77,5

# KINEMOON

## KINEMOON-INSTALLATIONSARTEN

### 1. Montage auf Fertigfußboden mit Wannenfüßen und Fliesensockel

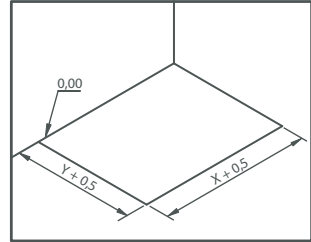
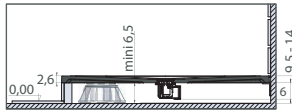

Montagevorbereitung Fertigfußboden mit Wannenfüße

### 2. Wird im Widerlager gegen die Fliese montiert

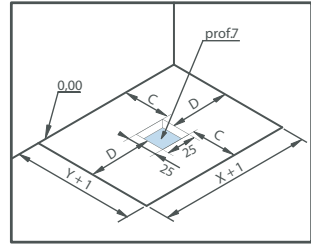
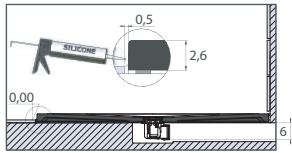
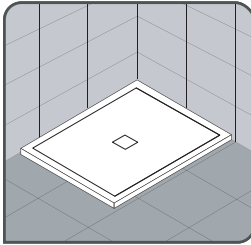

Montagevorbereitung Fertigfußboden mit Wannenfüße

### 3. Bodengleiche Montage mit Wannenfüße

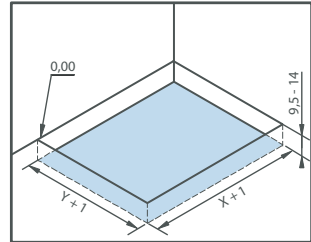
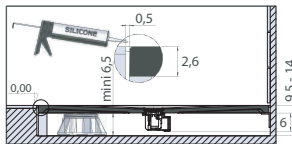

Montagevorbereitung Fertigfußboden mit Wannenfüße

### 4. Bodengleiche Montage ohne Wannenfüße

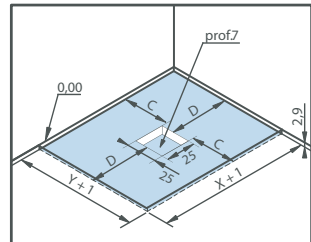
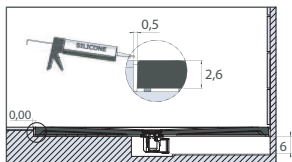
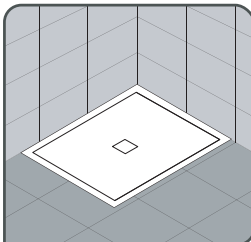

Montagevorbereitung Fertigfußboden mit Wannenfüße

- F Mise en place des plots de colle polyuréthane ou MS polymère
- GB Loading the plots glue polyurethane or MS polymer
- E Ubicacion de los puntos de pegamento poliuretano o polimero MS
- I Posizione dei punti di colla poliuretanica o MS polimero
- NL Breng de polyuretaan lijm of MS polymeer aan op de juiste plaats
- D Bringen Sie den Polyurethan-/MS-Polymer-Kleber auf

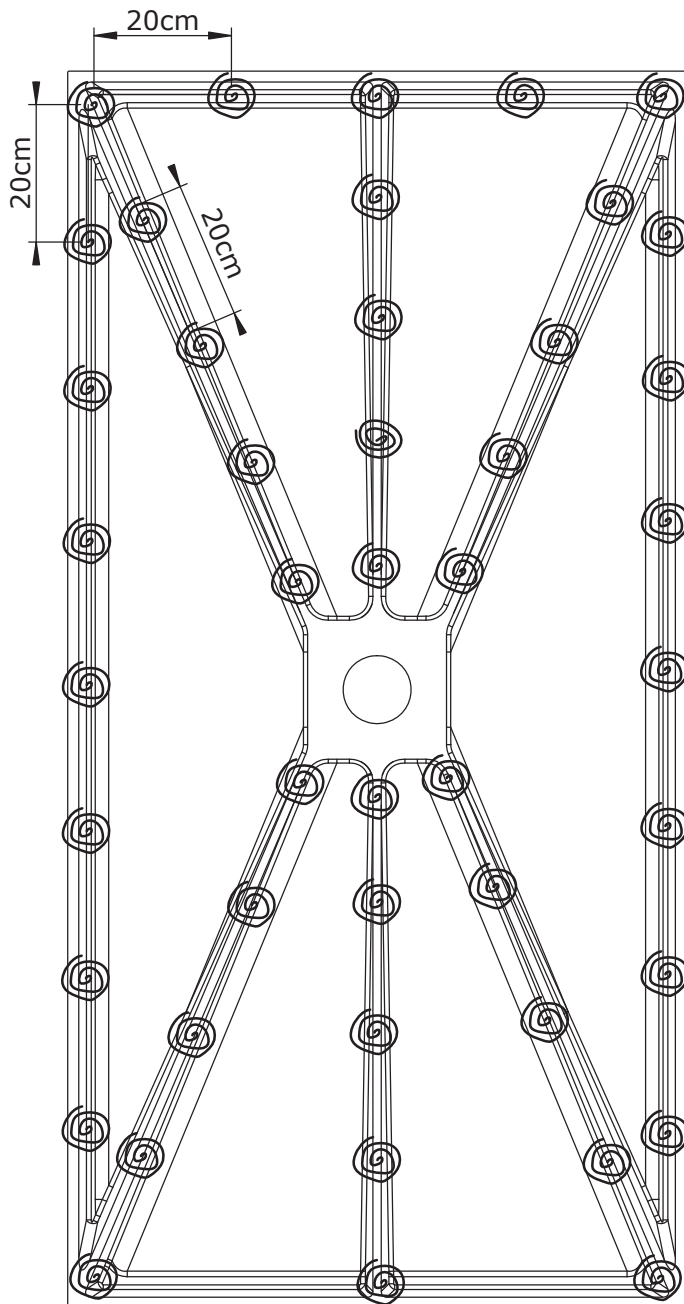





24h

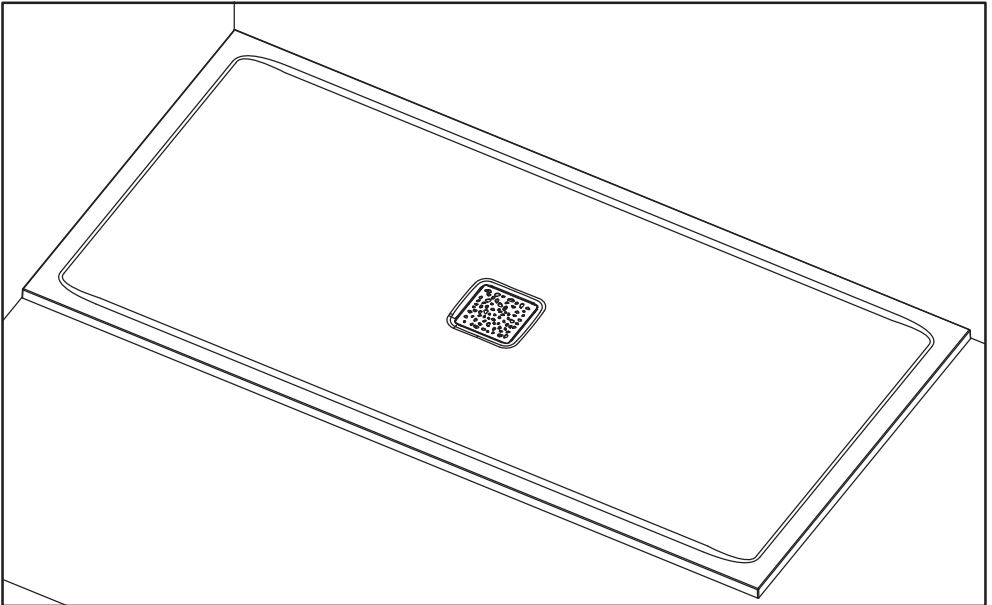





AQUAPRODUCTION, Site industriel,  
F - 44680 Chaumes-en-Retz

19

**EN 14527 - CL2**

Aptitude au nettoyage : satisfaisant

Durabilité : satisfaisant



**SAV**  
**SERVICE HELPLINES**  
**ASSISTENZA POST- VENDITA**  
**SERVICIO POSTVENTA**

**FRANCE**

02 40 21 29 45

**UK**

020 8842 0033

**IRELAND**

04697 33102

**DEUTSCHLAND**

+49 (0) 6074 / 30928 0

**ITALIA**

(0382) 6181

**ÖSTEREICH**

+43 1 710 60 70

**SCHWEIZ**

(01) 748 17 44

**ESPANA**

93 544 60 76

**NEDERLAND**

+31 475 487 100

**BELGIË**

+31 475 487 100

**BELGIQUE**

+31 475 487 100

**РОССИЯ**

963 19 40, 773 67 22

**PORTUGAL**

219 112 785