

KineStyle

AQUALIGHT

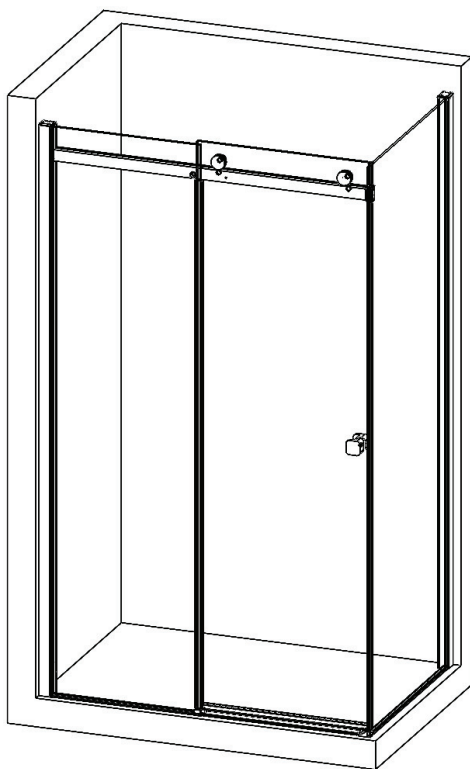

- Instructions de montage- FR
Nettoyage et entretien-
- Instructions Manual- GB
Cleaning and maintenance-
- Istruzioni di montaggio- IT
Pulizia e manutenzione-
- Montageinstructies- NL
Reiniging en onderhoud-
- Instrucciones de montaje- ES
Limpieza y mantenimiento-
- Montageanweisungen- D
Reinigung und wartung-

DES1053-F

**Avant l'installation
Before installation
Prima dell'installazione
Voor de installatie
Antes de la instalación
Vor der Installation**



Nous vous remercions d'avoir
choisi notre produit

Thank you for choosing our
product

Vi ringraziama per aver scelto un
nostro prodotto

Wij danken u dat u voor ons
product heeft gekozen

Le agradecemos que haya elegido
un producto nuestro

Vielen Dank, dass Sie sich für
unser Produkt entschieden haben

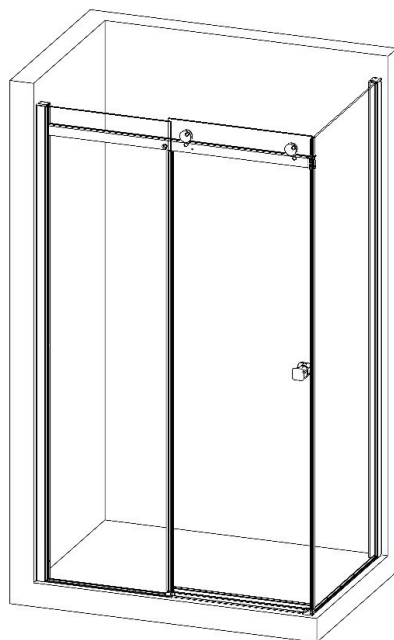

FR IMPORTANT
Avant de commencer l'installation,
lire ce livret d'instructions.

GB IMPORTANT
Before starting the installation, please
read this instructions booklet.

IT IMPORTANTE
Prima di iniziare l'installazione
leggere il presente libretto istruzioni.

NL BELANGRIJK
Lees dit instructieboekje voordat
u met de installatie begint.

ES IMPORTANTE
Antes de empezar con la instalación
lea el manual de instrucciones.

D WICHTIG
Lesen Sie diese Bedienungsanleitung,
bevor Sie mit der Installation beginnen

Avant l'installation
Prima dell'installazione
Before installation
Voor de installatie
Antes de la instalación
Vor der Installation

- FR**
- Une fois les composants retirés des emballage, vérifier visuellement qu'ils soient sans défaut.
 - Signaler tout défaut au fournisseur avant l'assemblage des différentes parties de l'installation.
 - Il ne sera possible d'accepter les réclamations relatives à des imperfections du produit qu'A CONDITION que celles-ci soient signalées avant l'assemblage des différentes parties et avant l'installation.
-
- GB**
- Once the components have been removed from the packaging, visually check that they are not damaged/defected.
 - Report any defects to the supplier before assembling the different parts of the installation.
 - Product parts will only be accepted as defected if they are reported before assembly of the different parts and before installation.
-
- IT**
- Dopo aver rimosso i componenti dagli imballi, verificare visivamente che gli stessi non presentino difetti.
 - Qualsiasi difetto deve essere segnalato al fornitore prima dell'assemblaggio delle varie parti e dell'installazione.
 - Qualsiasi reclamo relativo a imperfezioni del prodotto sarà accettato SOLO se segnalato prima dell'assemblaggio delle varie parti e dell'installazione.
-
- NL**
- Controleer visueel na de onderdelen uit de verpakking te hebben gehaald of de componenten defecten vertonen.
 - Elk defect moet worden gemeld aan de leverancier vóór montage van de verschillende onderdelen en installatie.
 - Eventuele klachten over onvolmaaktheden van het product worden UITSLUITEND geaccepteerd indien gemeld vóór de montage van de verschillende onderdelen en installatie.
-
- ES**
- Después de haber quitado los embalajes, comprobar visualmente que los componentes no presenten defectos.
 - Cualquier defecto debe ser indicado al proveedor antes del ensamblaje de las diferentes partes y de la instalación, en un plazo de 24 horas.
 - Cualquier reclamación relativa a imperfecciones del producto será aceptada SOLAMENTE si se indica antes del ensamblaje de las diferentes partes y de la instalación, dentro del plazo indicado.
-
- D**
- Führen Sie, nachdem alle Bestandteile ausgepackt sind, eine Sichtprüfung durch, um sicherzustellen, dass sie keine Mängel aufweisen.
 - Melden Sie eventuelle Mängel dem Lieferanten, bevor Sie die verschiedenen Teile montieren.
 - Beanstandungen von Produktmängeln können NUR DANN akzeptiert werden, wenn sie vor der Montage der verschiedenen Teile und vor dem Einbau gemeldet werden.

Table des matières
Table of contents
Indice
Inhoudstafel
Indice
Inhaltsverzeichnis

FR	- Composants fournis	Pag. 5
	- Séquence de montage	Pag. 13
	- Informations sur l'utilisation	Pag. 42
	- Nettoyage et entretien	Pag. 44
GB	- Usage information	Pag. 5
	- Assembly sequence	Pag. 13
	- Supplied components	Pag. 42
	- Cleaning and maintenance	Pag. 44
IT	- Componenti forniture	Pag. 5
	- Sequenza di montaggio	Pag. 13
	- Informazioni sull'utilizzo	Pag. 42
	- Pulizia e manutenzione	Pag. 44
NL	- Geleverde onderdelen	Pag. 5
	- Montagevolgorde	Pag. 13
	- Informatie over het gebruik	Pag. 42
	- Reiniging en onderhoud	Pag. 44
ES	- Componentes entregados	Pag. 5
	- Secuencia de montaje	Pag. 13
	- Informaciones sobre el uso	Pag. 42
	- Limpieza y mantenimiento	Pag. 44
D	- Gelieferte Komponenten	Pag. 5
	- Montagereihenfolge	Pag. 13
	- Informationen über die Verwendung	Pag. 42
	- Reinigung und Wartung	Pag. 44



Exécuter l'installation et l'assemblage
de la cabine en respectant la séquence illustrée

Perform the installation and assembly of the enclosure
following the step by step instructions.

Eseguire l'installazione e l'assemblaggio della cabina
chiusura rispettando la sequenza illustrata.





Voer de installatie en montage van de douchecabine
in de aangegeven volgorde uit



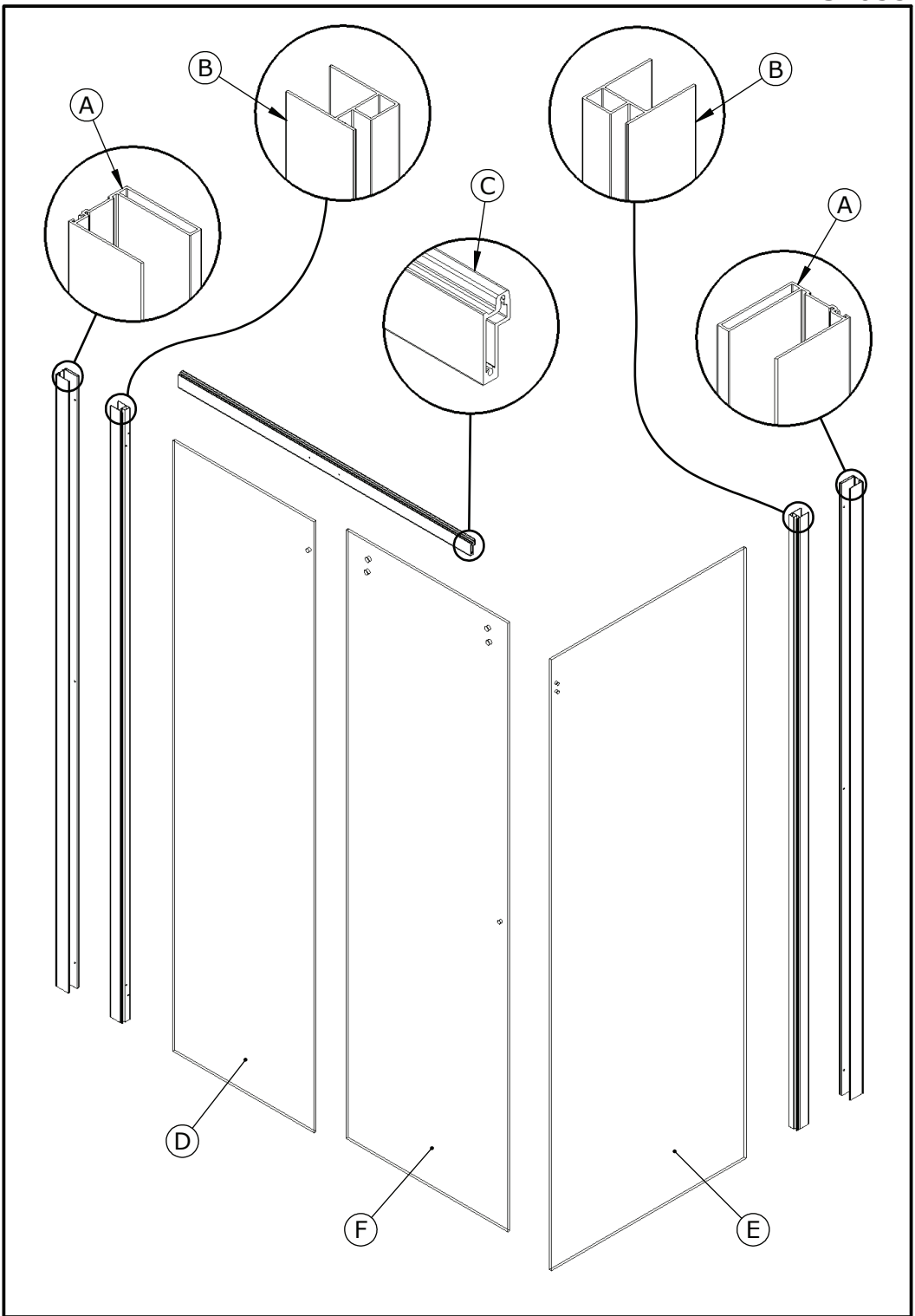

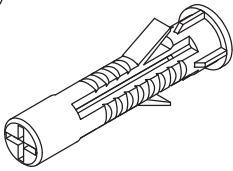
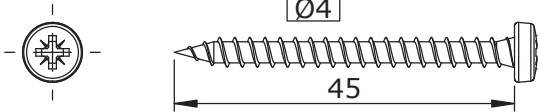

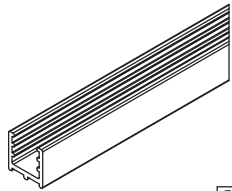
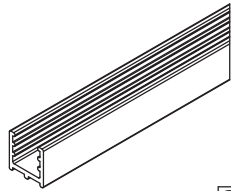
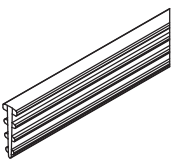
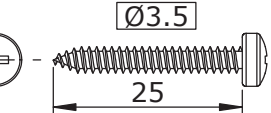
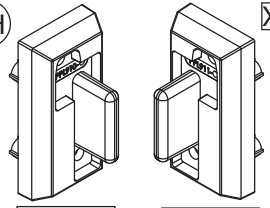
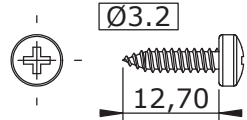
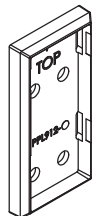
Realizar la instalación y el ensamblaje de la cabina
respetando la secuencia ilustrada.

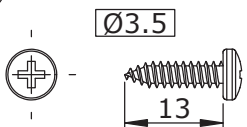
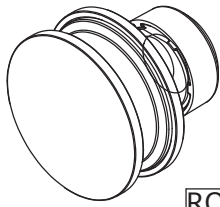
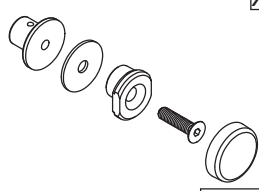
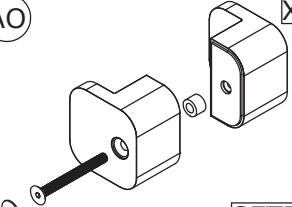
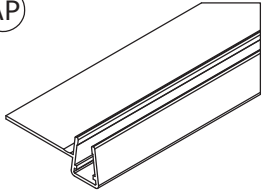
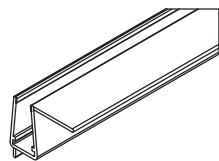
Führen Sie den Einbau und Montage der Kabine
in der angegebenen Reihenfolge durch

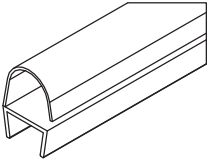
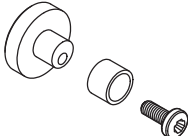
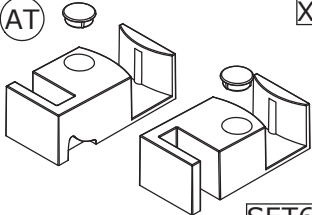
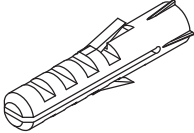
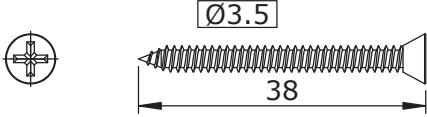
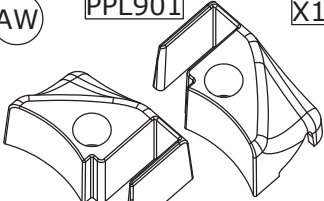

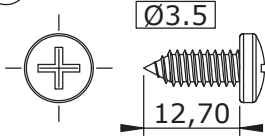
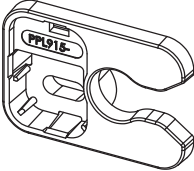
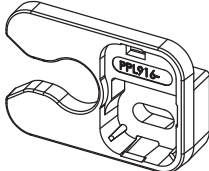

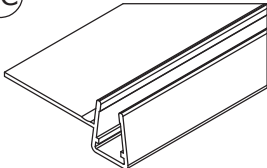
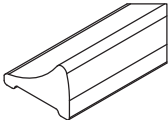
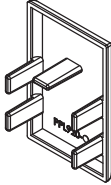
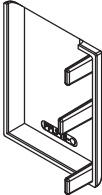
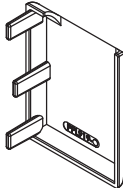
<p>AA X6</p>  <p>CHE02</p>	<p>AC X6</p>  <p>1=1</p> <p>VIS210</p>	
<p>AB X6</p>  <p>RON05</p>	<p>AD X1</p>  <p>6142</p>	<p>AE X1</p>  <p>6142</p>
<p>AF X2</p>  <p>Lg=1984mm</p> <p>J637</p>	<p>AG X4</p>  <p>1=1</p> <p>VIS3.5x25</p>	<p>AH X1</p>  <p>PPL910 PPL911</p>
<p>AI X2</p>  <p>1=1</p> <p>VIS3.2x12.7</p>	<p>AJ X1</p>  <p>PPL912</p>	<p>AK X1</p>  <p>PPL913</p>
<p>AL X6</p>  <p>1=1</p> <p>VIS117</p>	<p>AM X2</p>  <p>ROU40</p>	<p>AN X2</p>  <p>SET66</p>
<p>AO X1</p>  <p>SET70</p>	<p>AP X1</p>  <p>Lg=1863mm</p> <p>J636</p>	<p>AQ X1</p>  <p>JOI258</p>

<p>AR X1</p>  <p>J645</p>	<p>AS X1</p>  <p>SET68</p>	<p>AT X1</p>  <p>SET65</p>
<p>AU X2</p>  <p>CHE03</p>	<p>AV X2</p>  <p>1=1</p> <p>VIS42</p>	
<p>AW X1</p> <p>PPL901</p>  <p>PPL902</p>	<p>AX X8</p>  <p>CAP19</p>	<p>AY X2</p>  <p>1=1</p> <p>VIS132</p>
<p>AZ X1</p>  <p>PPL915</p>	<p>BA X1</p>  <p>PPL916</p>	<p>BB X2</p>  <p>PPL917</p>
<p>BC X1</p>  <p>Lg=1854mm</p> <p>J635</p>	<p>BD X1</p>  <p>5905</p>	<p>BE X2</p>  <p>PPL920</p>
<p>BF X1</p>  <p>PPL918</p>	<p>BG X1</p>  <p>PPL919</p>	<p>BH X5</p>  <p>CAP20</p>

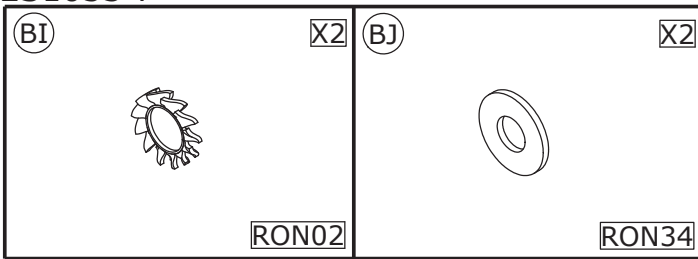

MATERIEL NÉCESSAIRE
 TOOLS REQUIRED
 MATERIALE NECESSARIO
 NODIGE GEREEDSCHAP
 MATERIAL NECESARIO
 BENODIGTE WERKZEUGE

Colle polyuréthane
 Polyurethane glue
 Colla poliuretano
 Lijm polyurethaan
 Pegamento poliuretano
 Polyurethan-Klebstoff

Non acétique
 Silicone sealant
 Non acetico
 Zonder azijnzuur
 No acética
 Nicht essigsauer

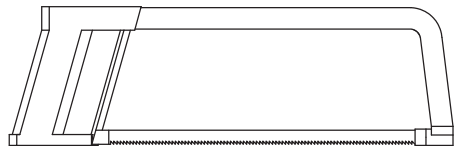
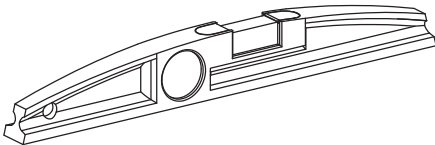
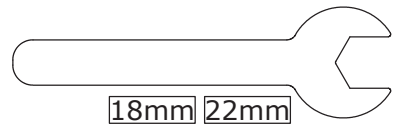
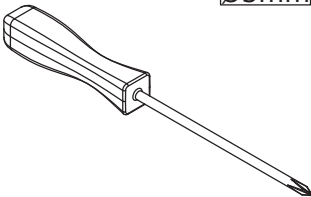
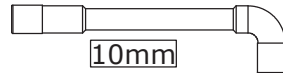
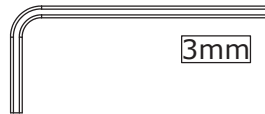
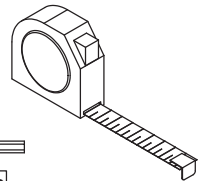
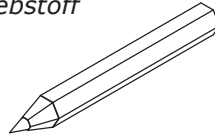
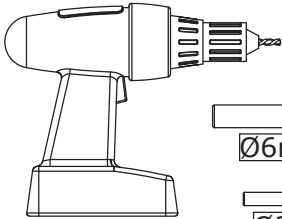
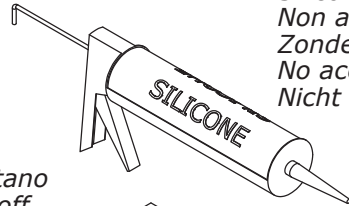
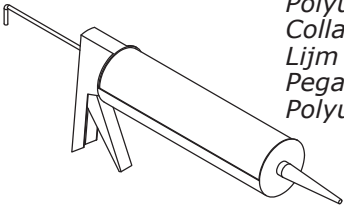

REVERSIBILITE / REVERSIBLE / REVERSIBILITA
OMKEERBAARHEID / REVERSIBILITA / WAHLWEISE MONTAGE

MONTAGE A GAUCHE / LEFT INSTALLATION
MONTAGGIO A SINISTRA / MONTAGE LINKS
MONTAJE A LA IZQUIERDA / MONTAGE LINKS

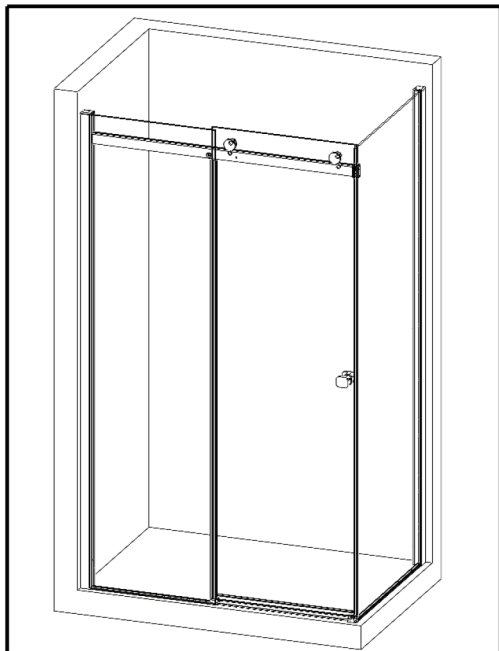

MONTAGE A DROITE / RIGHT INSTALLATION
MONTAGGIO A DESTRA / MONTAGE RECHTS
MONTAJE A LA DERECHA / MONTAGE RECHTS

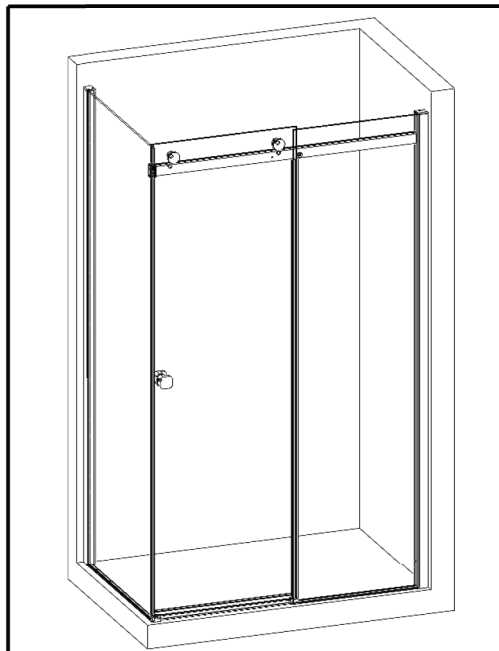

Vous avez la possibilité de réaliser un montage à droite ou un montage à gauche. Notre notice d'installation décrit un montage à gauche. si vous voulez réaliser un montage à droite, il vous suffit d'inverser le montage.

You have the option of mounting on the right or on the left. our installation instructions describe mounting on the left. if you want to mount on the right, simply reverse the mounting.

Avete la possibilità di effettuare il montaggio a destra o a sinistra. Il nostro manuale descrive il montaggio a sinistra. Se volete realizzare il montaggio a destra è sufficiente invertire varie fasi di montaggio.

U kunt de cabine rechts of links monteren. Onze handleiding beschrijft de linkse montage van de cabine. Keer de montage om als u de cabine rechts wilt monteren.

Puede realizar un montaje a la derecha o un montaje a la izquierda. Nuestra folleto de instalación describe un montaje a la izquierda. Si desea montar su cabina a la derecha solo tendrá que realizar el montaje al contrario.

Sie haben die Möglichkeit, eine Montage auf der linken Seite oder eine Montage auf der rechten Seite durchzuführen. Unsere Montageanleitung beschreibt eine Montage auf der linken Seite. Wenn Sie die Montage lieber auf der rechten Seite durchführen wollen, müssen Sie nur den Montageprozess umkehren.



Remarque importante - Important note
Nota importante - Belangrijke opmerking
Nota importante - Wichtiger Hinweis



Avant de commencer le montage, fermer l'eau.
Before starting the installation, turn off the water.
Prima di iniziare il montaggio chiudere l'acqua.
Sluit de watertoevoer af voordat u begint met de installatie.
Antes de empezar el montaje cierre el agua.
Stellen Sie das Wasser ab, bevor Sie mit der Installation beginnen

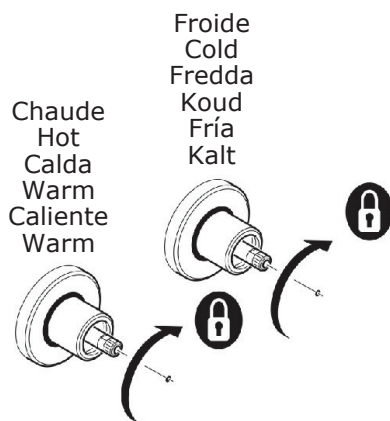
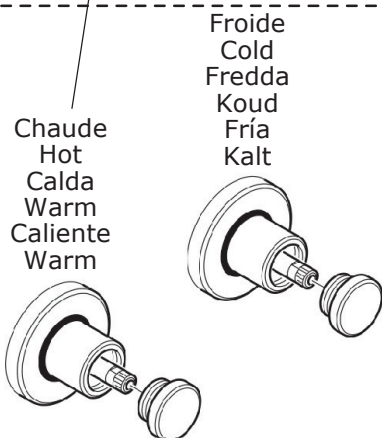
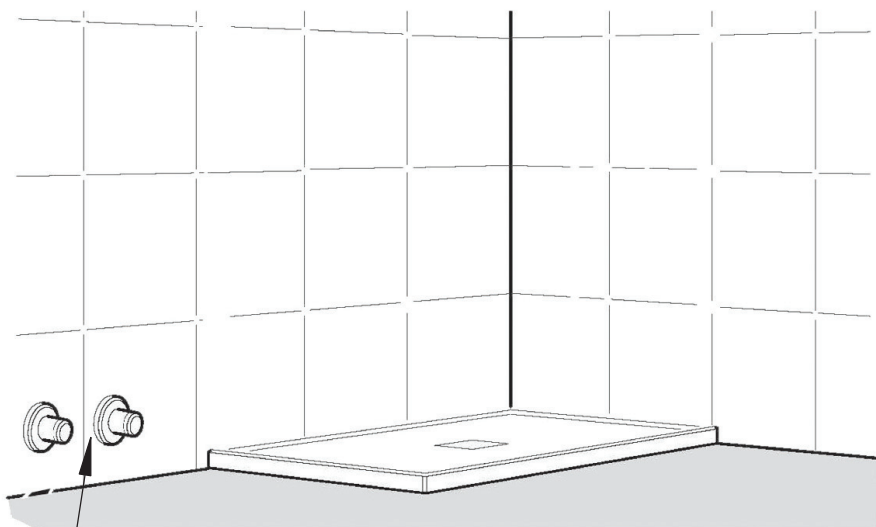



Remarque importante - Important note
Nota importante - Belangrijke opmerking
Nota importante - Wichtiger Hinweis



Vérifier que le receveur soit installé correctement
(Voir les instructions de montage receveur).
La paroi de douche ne permet pas de rattrapage de niveau.

Check that the shower tray is installed correctly
(See shower tray installation instructions).
The shower screen does not allow for a level adjustment

Vérificare che il piatto sia installato correttamente
(Vedere istruzioni montaggio piatto).
La pareti della cabina non consentono la regolazione di
eventuali dislivelli del piatto doccia.

Zorg ervoor dat de douchebak correct is geïnstalleerd
(Zie instructies voor montage douchebak).
De wanden van de cabine staan geen aanpassing van de
oneffenheden in de douche toe.

Comprobar que el plato está instalado correctamente
(Véanse las instrucciones del montaje del plato).
Las paredes de la cabina no permiten la regulación de las
irregularidades en la ducha.

Prüfen Sie, ob die Duschwanne korrekt montiert ist
(Siehe Installationsanleitungen Duschwanne).
Die Duschwand erlaubt es nicht, Höhenunterschiede auszugleichen.

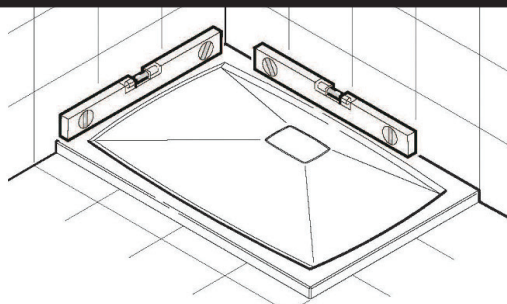

Protéger le receveur avec du carton ou du fil à bulles.

Protect the tray with cardboard or bubble wrap.

Proteggere il piatto con cartone o pluriball.

Scherm de douchebak af met karton of noppenfolie.

Proteger el plato con cartón o film alveolar.

Schützen Sie die Duschwanne mit Pappe oder Luftpolsterfolie.

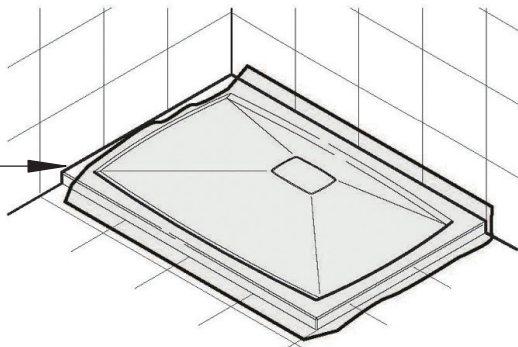

01

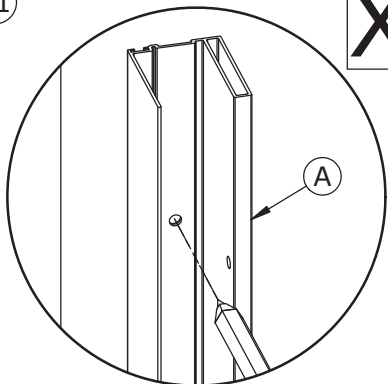
X6

Extérieur
 External
 Esterno
 Buitenzijde
 Externo
 Außen

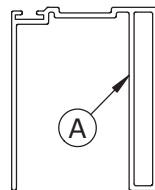

Intérieur
 Internal
 Interno
 Binnenzijde
 Interno
 Innen

Extérieur
 External
 Esterno
 Buitenzijde
 Externo
 Außen

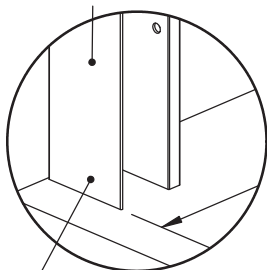

A

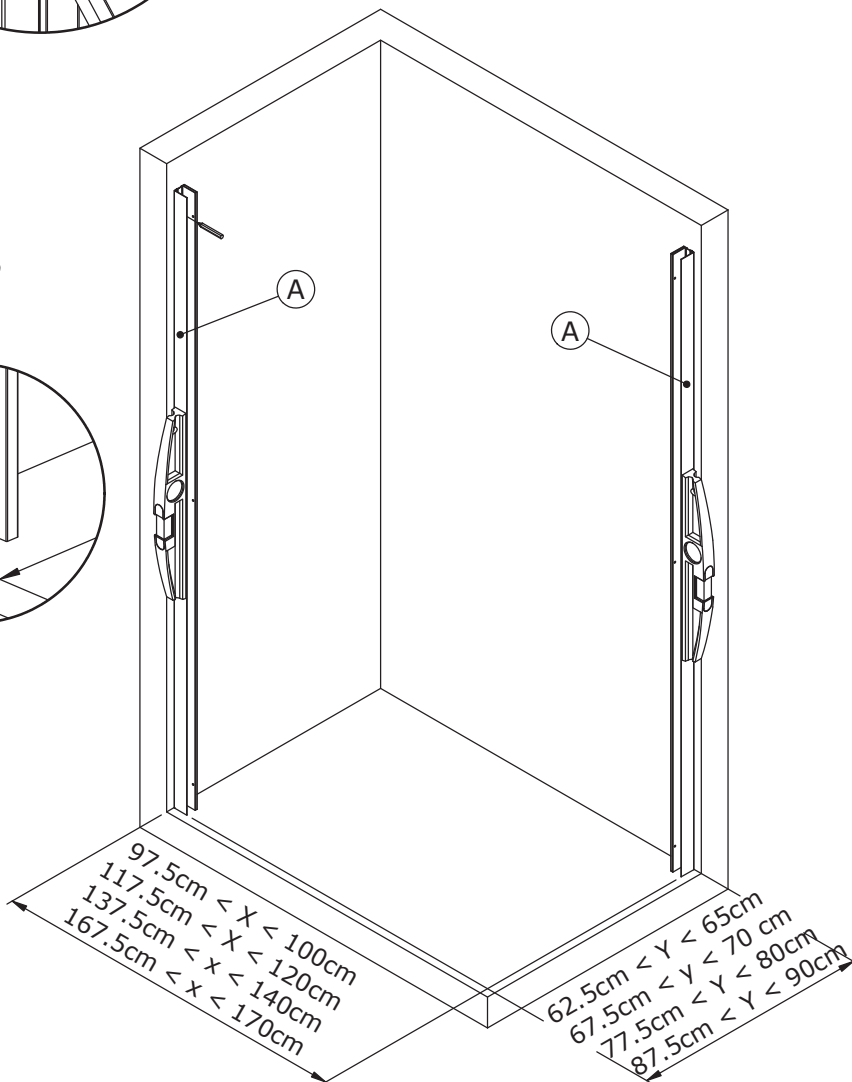

02

X2

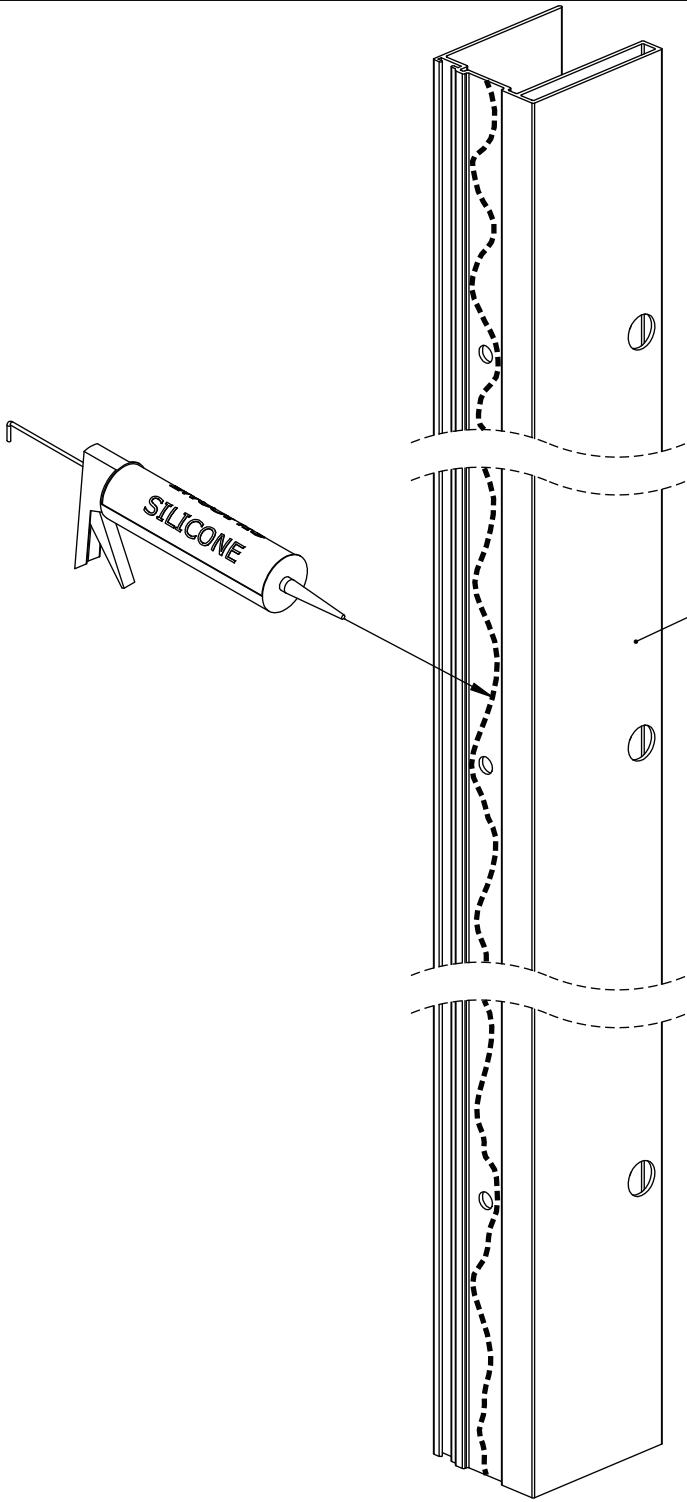

03

X6

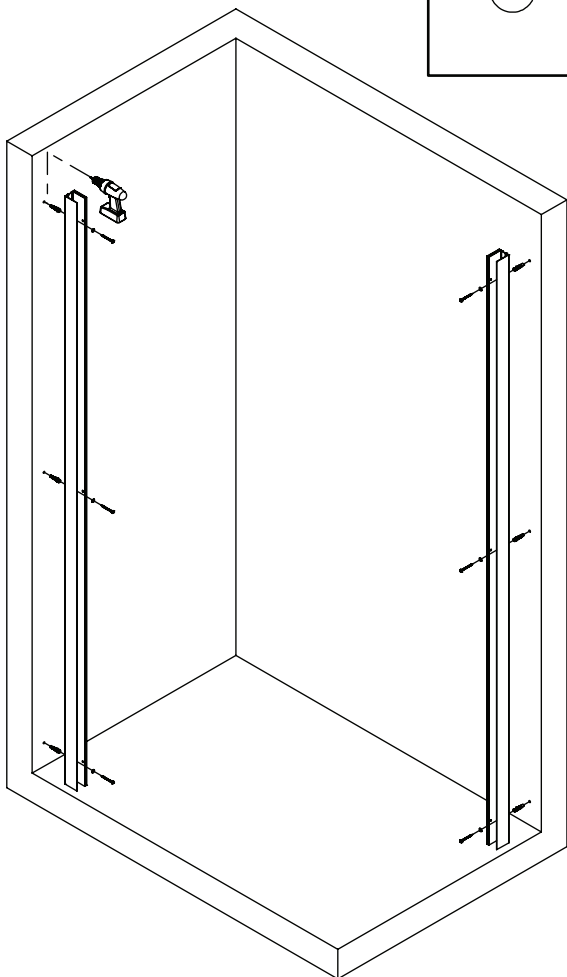
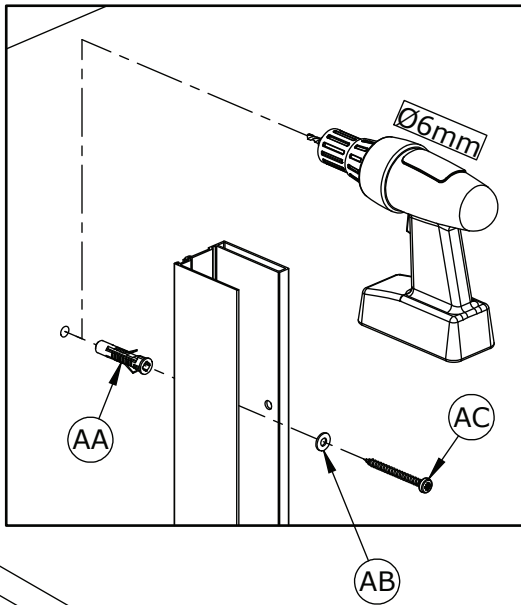

04

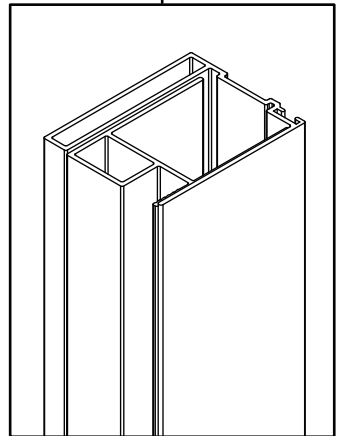
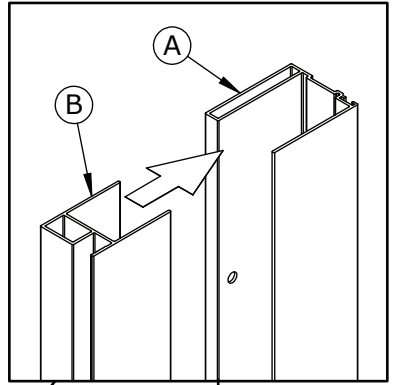
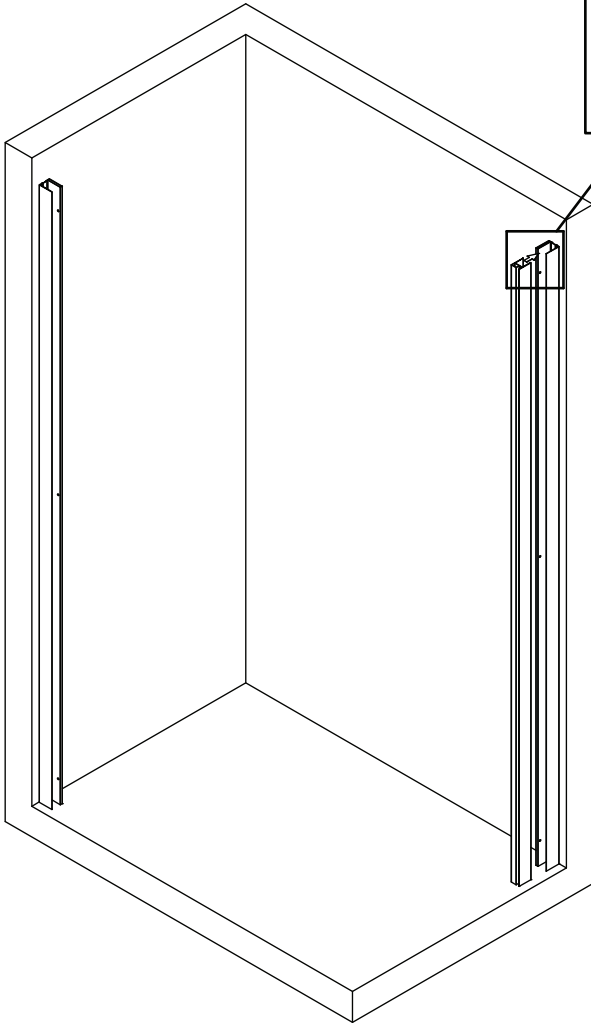

05

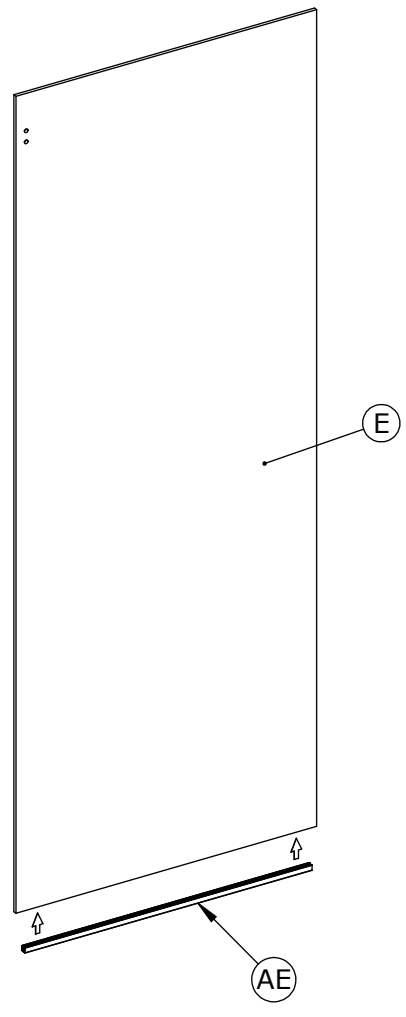
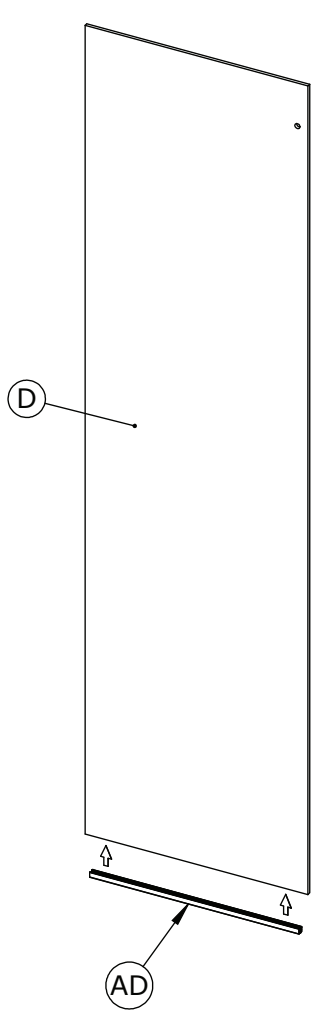
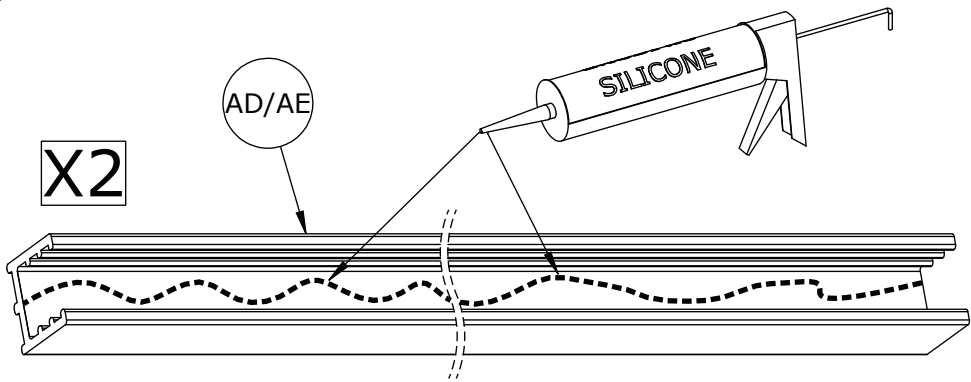

06

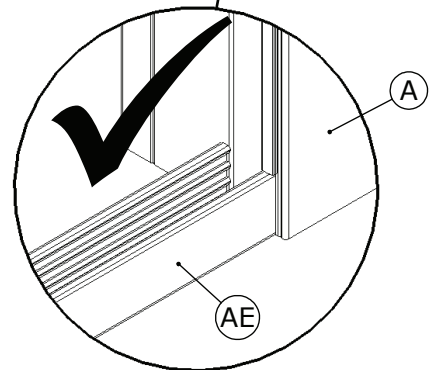
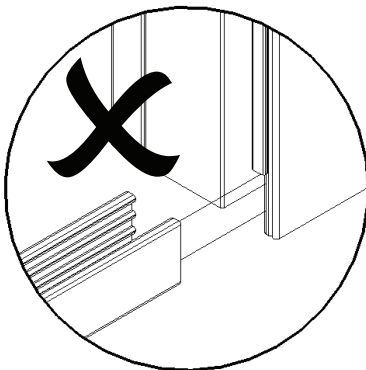
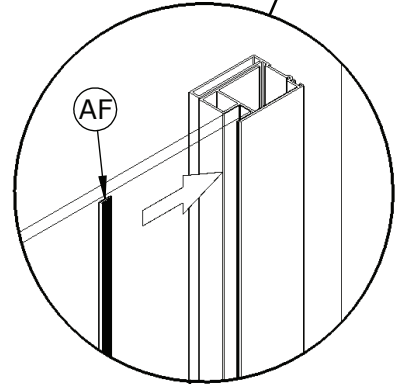
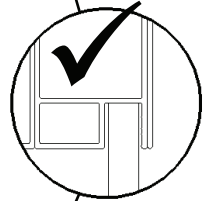
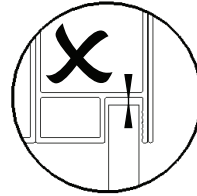
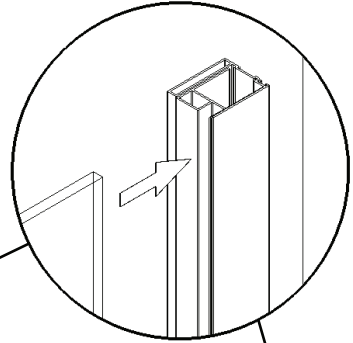
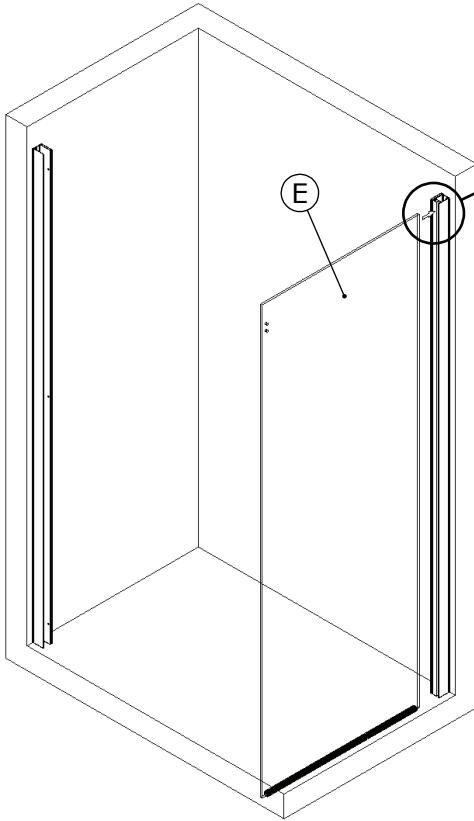

07

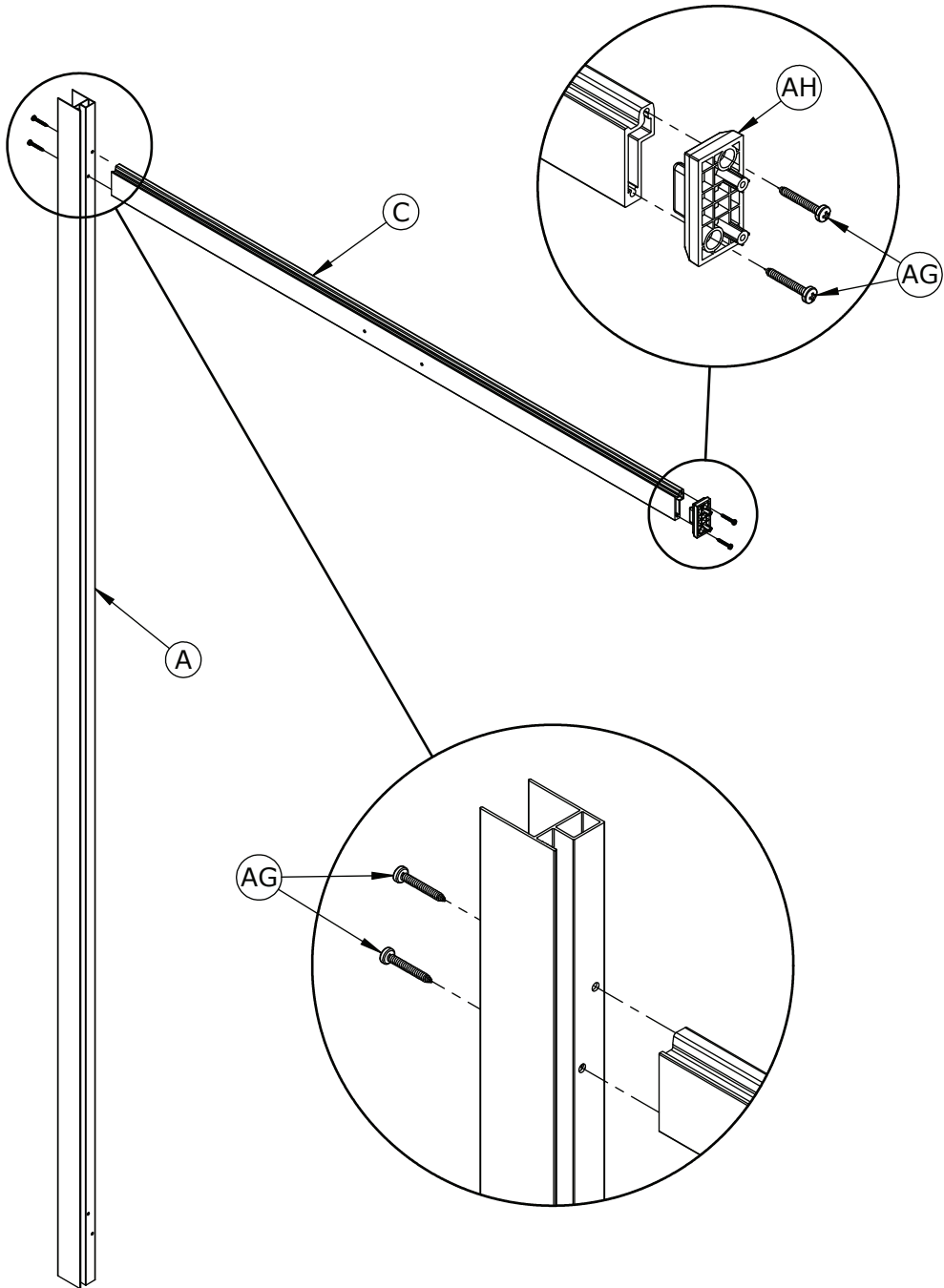

08

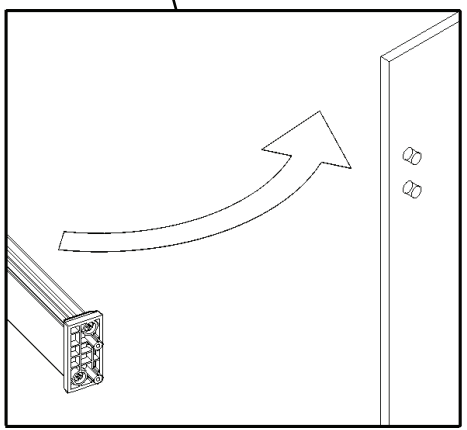
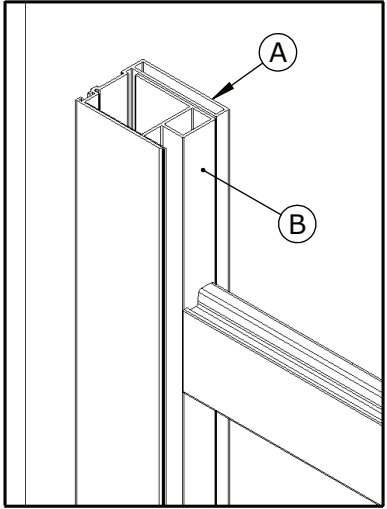
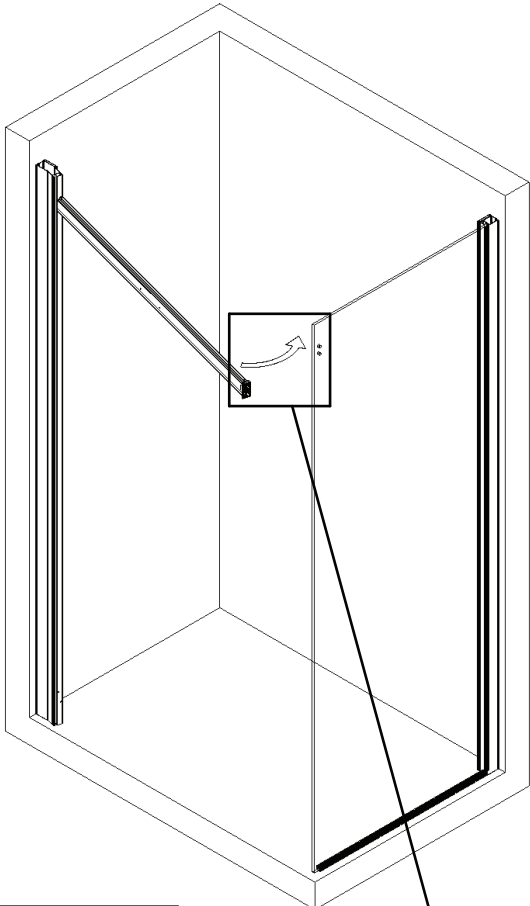

09

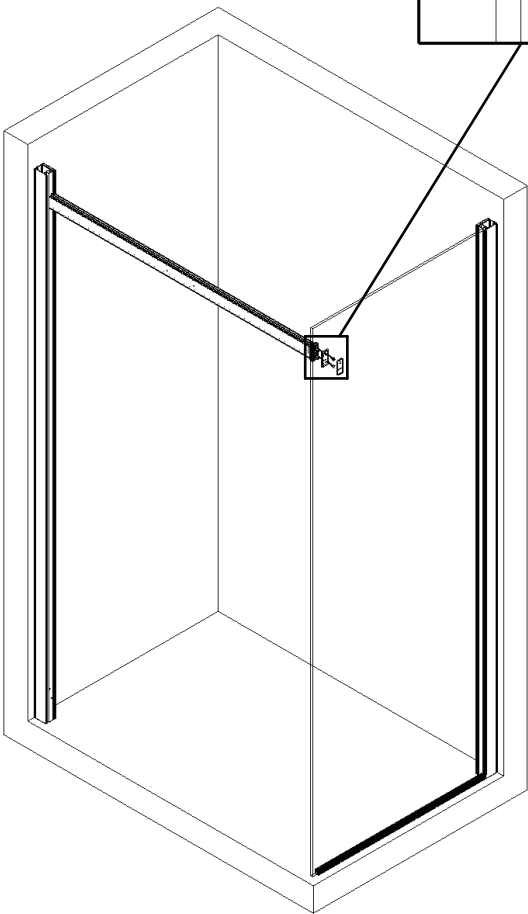
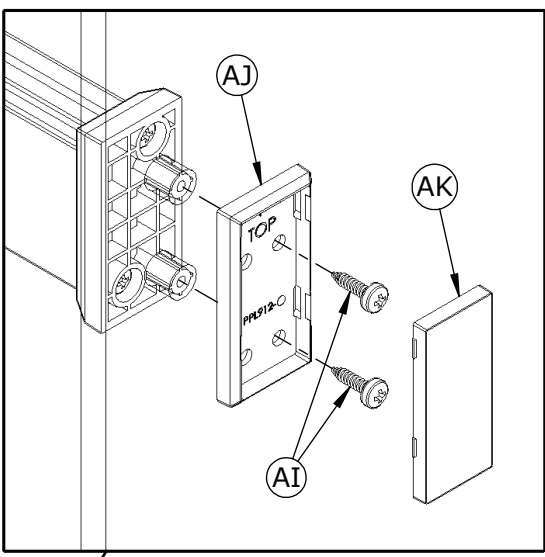

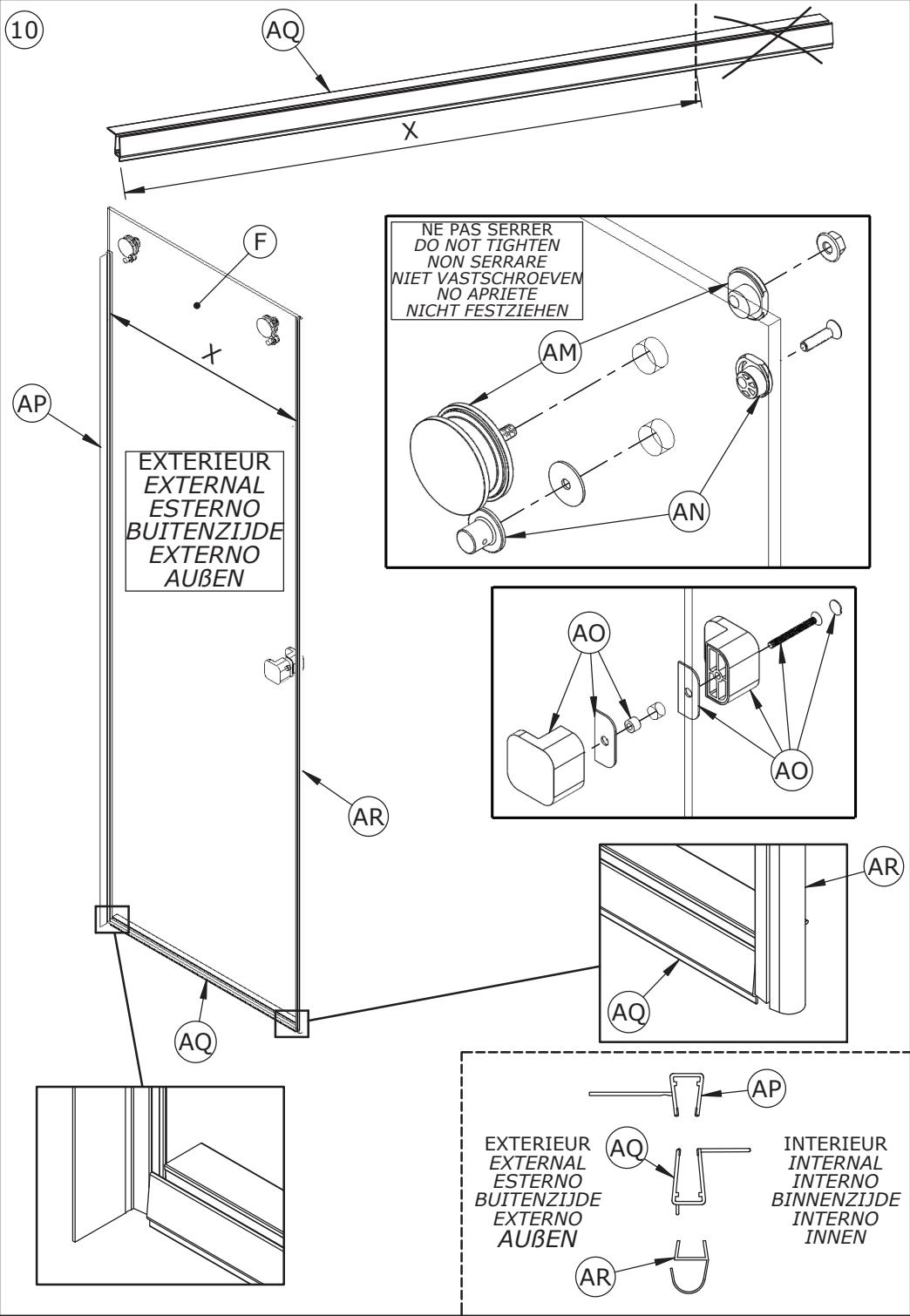

11

NE PAS SERRER
DO NOT TIGHTEN
NON STRINGERE FORTE
NIET VASTSCHROEVEN
NO APRIETE
NICHT FESTZIEHEN

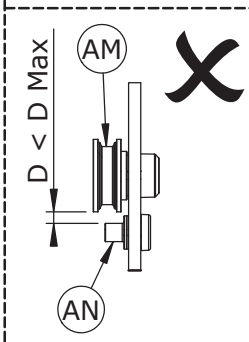
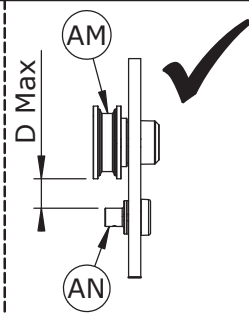
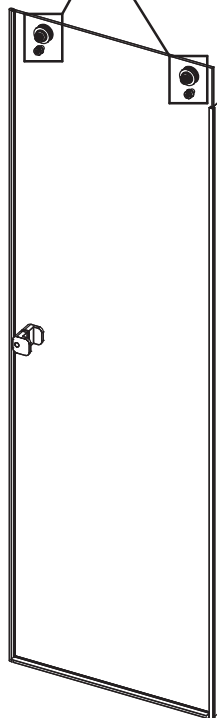
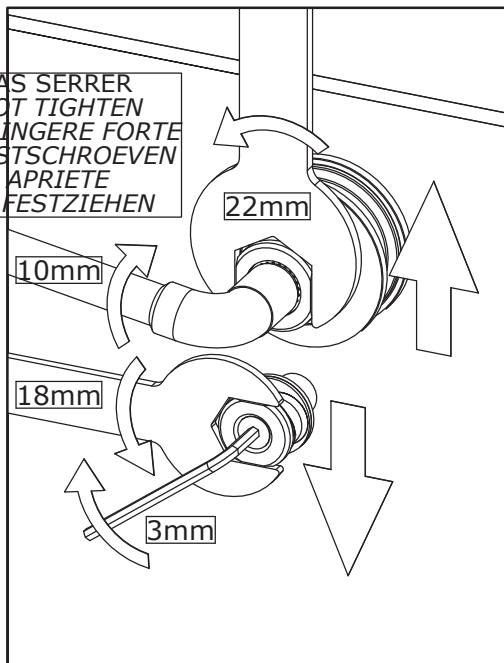

12

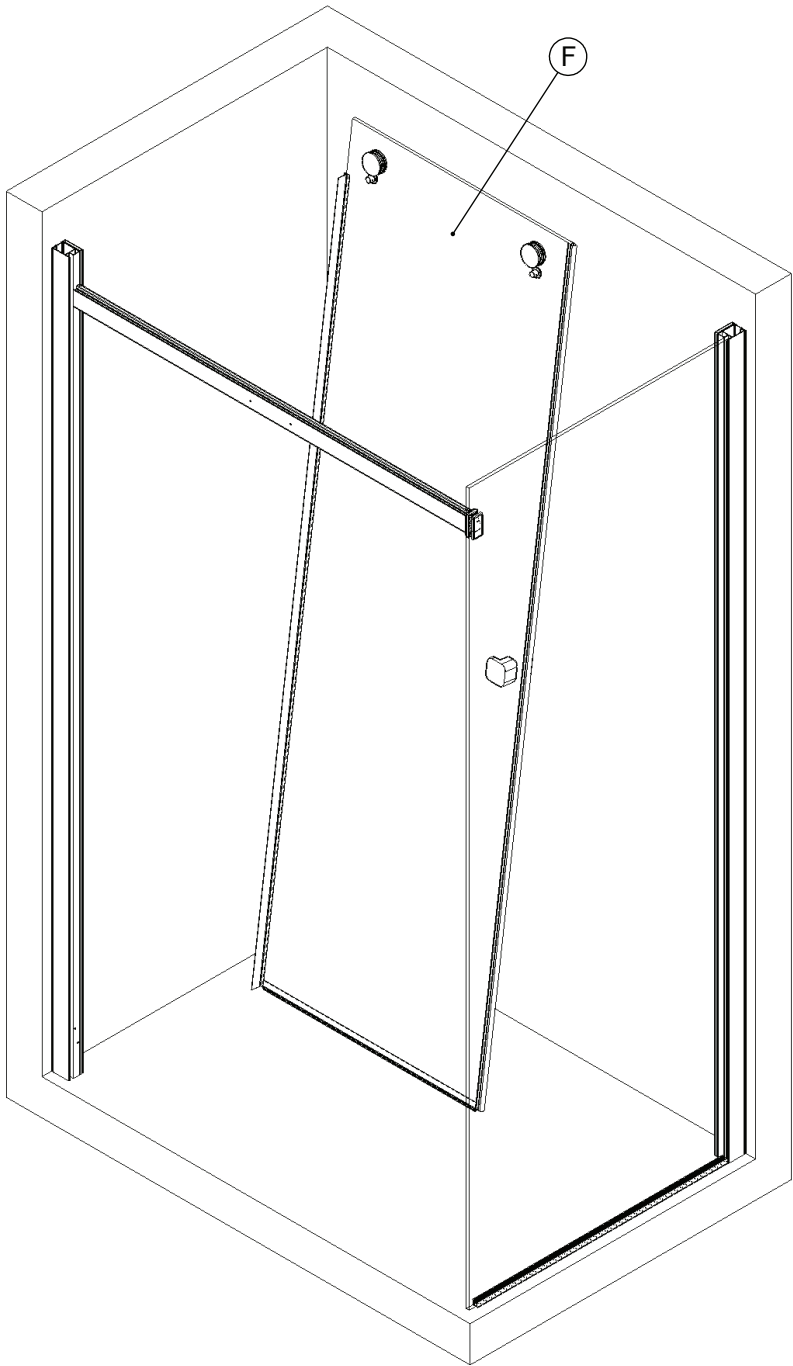

13

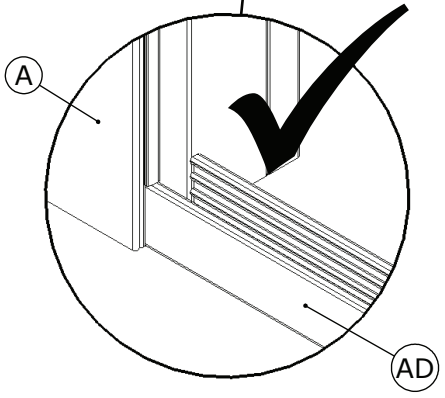
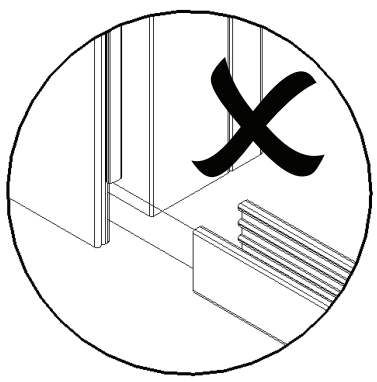
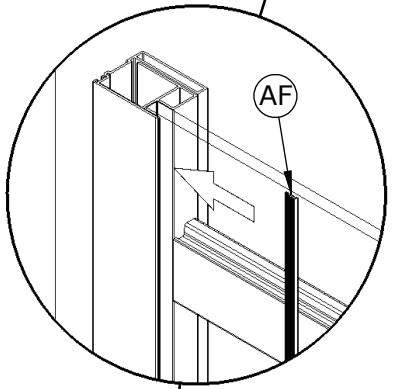
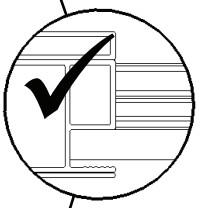
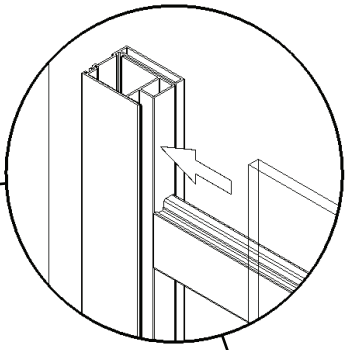
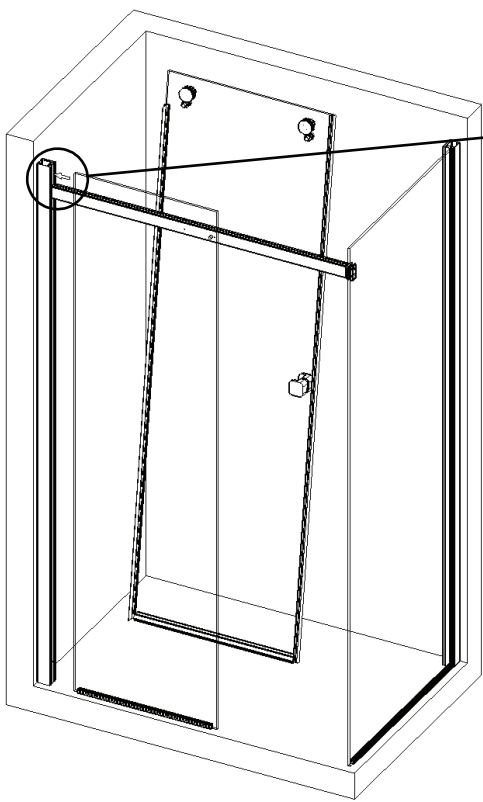

14

Pré-réglage avec excentrique
 Adjust before tightening
 Regolazione primaria con eccentrico
 Eerste afstelling met excentriek
 Ajustar el tornillo excéntrico sin apretar
 Exzentrerschraube ohne Anziehen einstellen

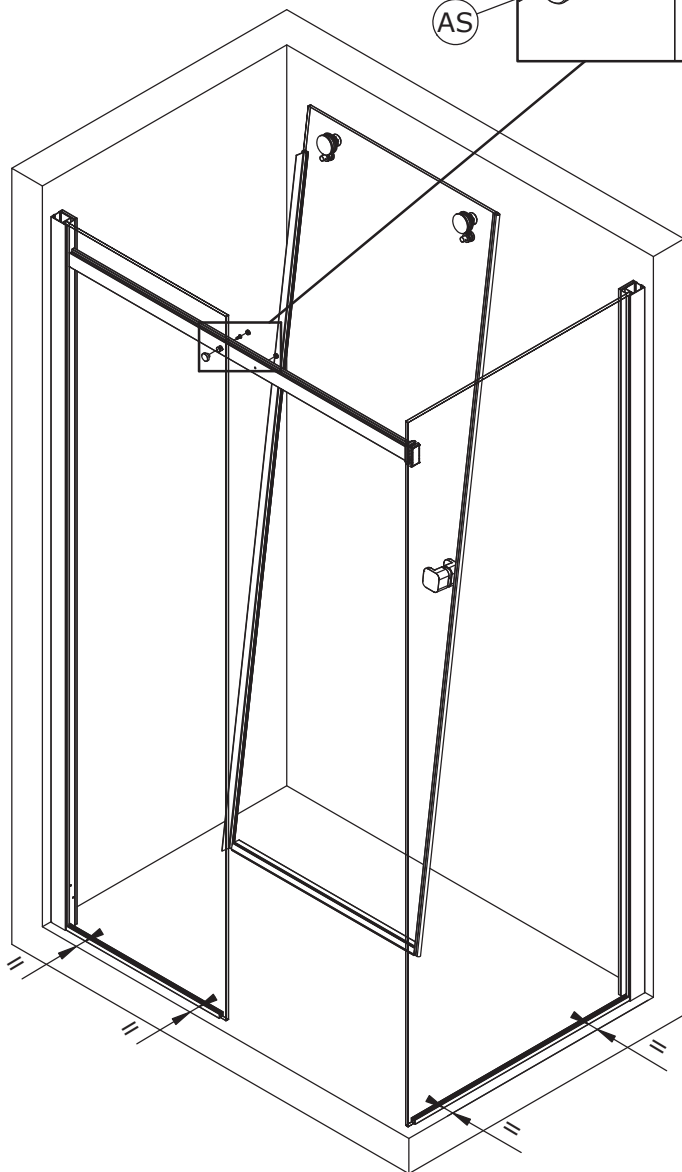
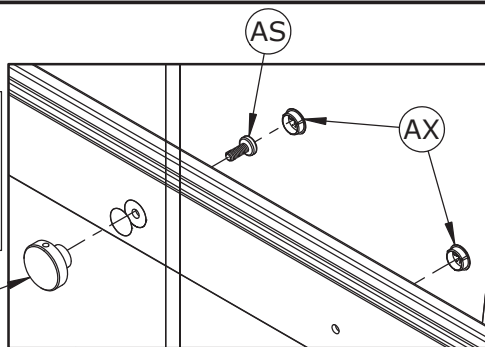

Montage avec receveur
Installation with tray
Montaggio con piatto
Assembleren met douchebak
Montaje con plato
Montage mit Empfänger

15

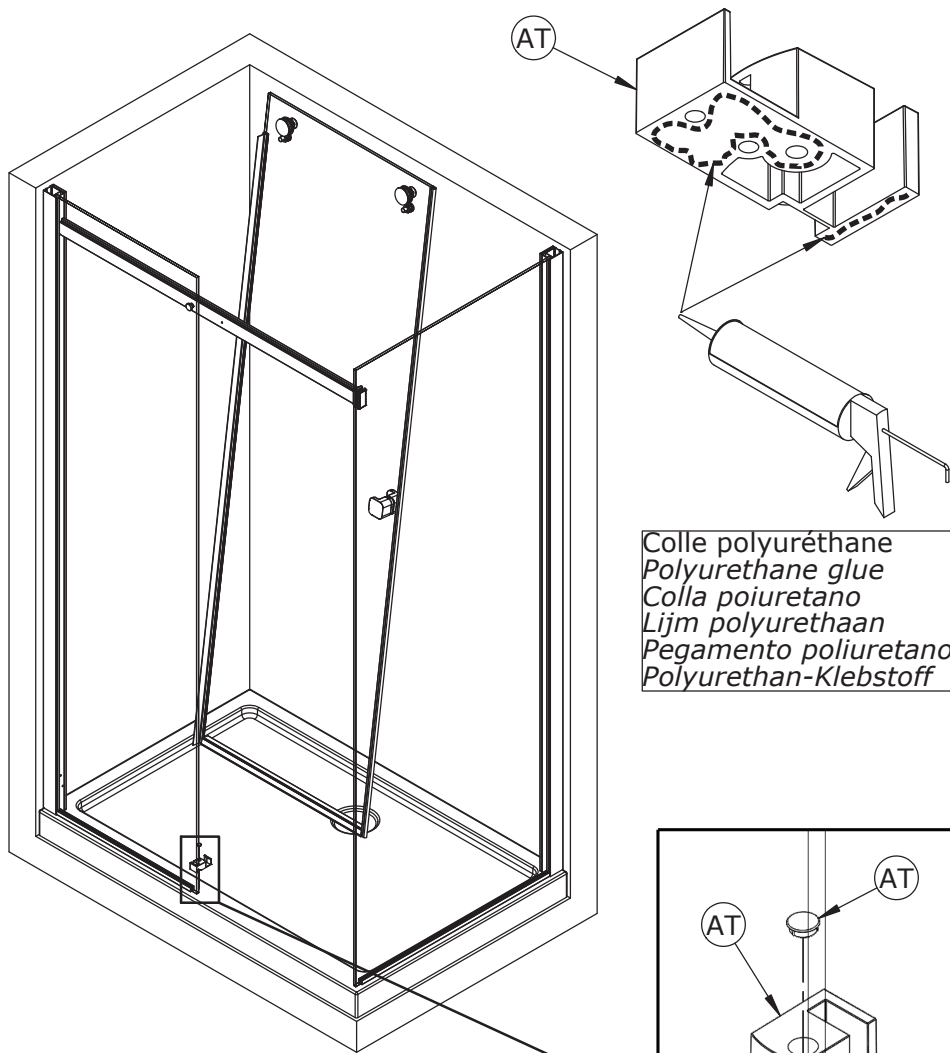

Colle polyuréthane
 Polyurethane glue
 Colla poliuretano
 Lijm polyurethaan
 Pegamento poliuretano
 Polyurethan-Klebstoff

Intérieur
 Internal
 Interno
 Binnenzijde
 Interno
 Innen

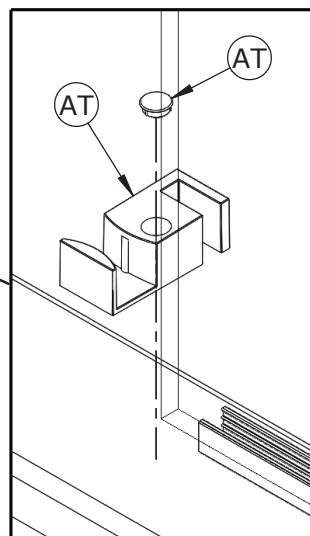

16

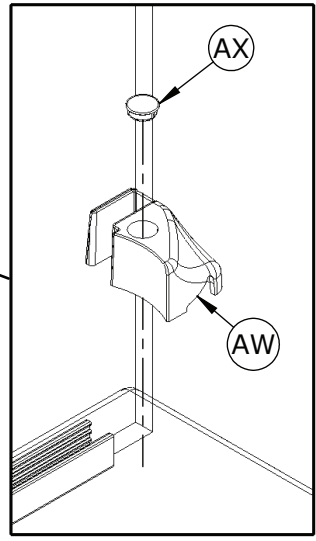
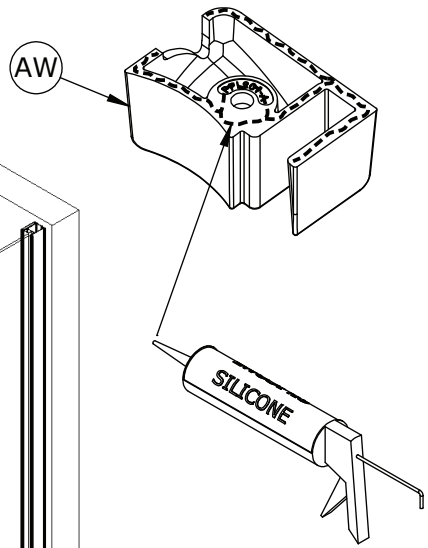
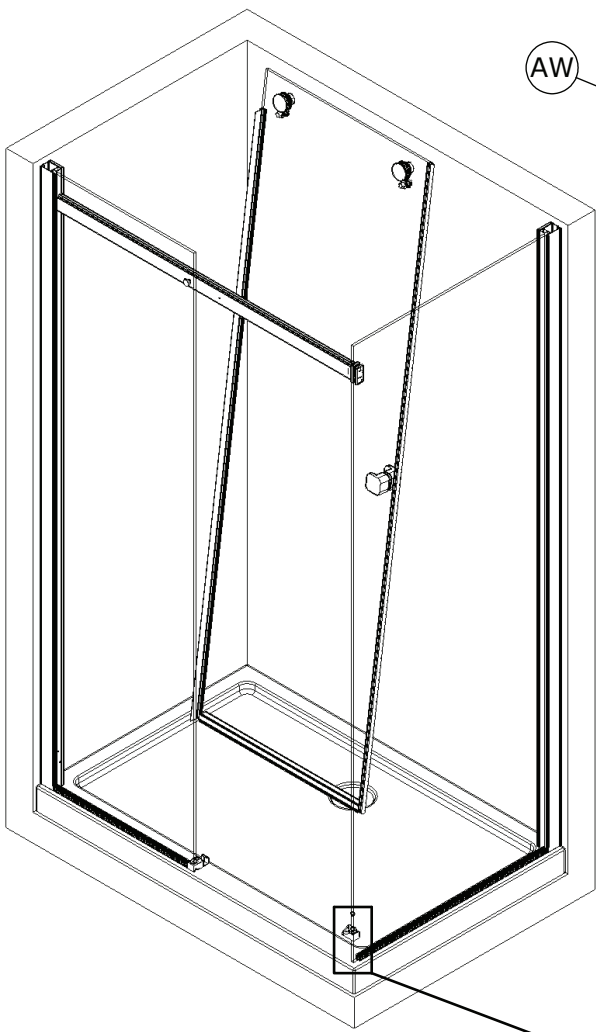

Montage sans receveur
Installation without tray
Montaggio senza piatto
Assembleren zonder douchebak
Montaje sin plato
Montage ohne Duschwanne

15b

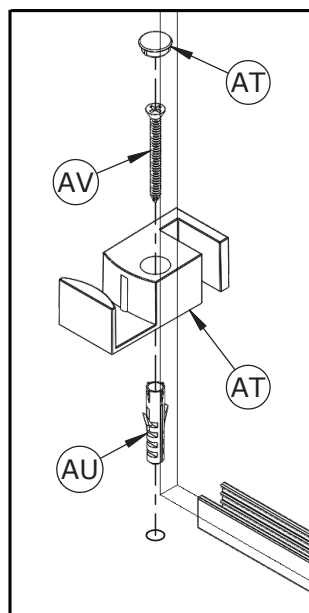
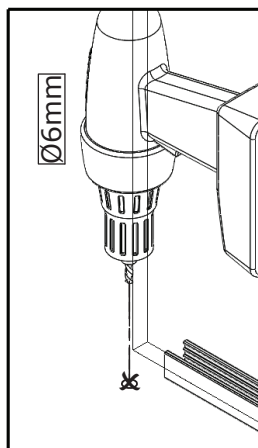
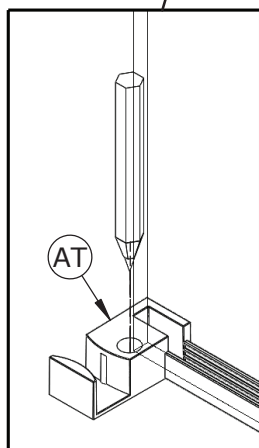
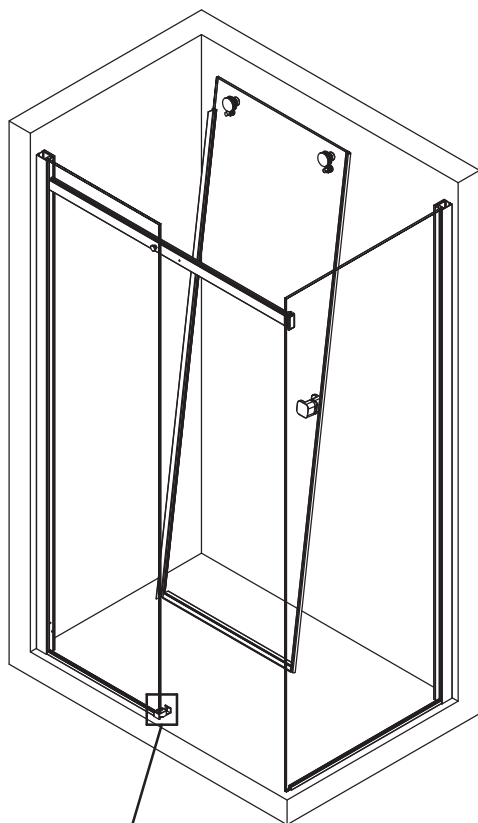

INTERIEUR - INTERNAL - INTERNO - BINNENZIJDE - INTERNO - INNEN

16b

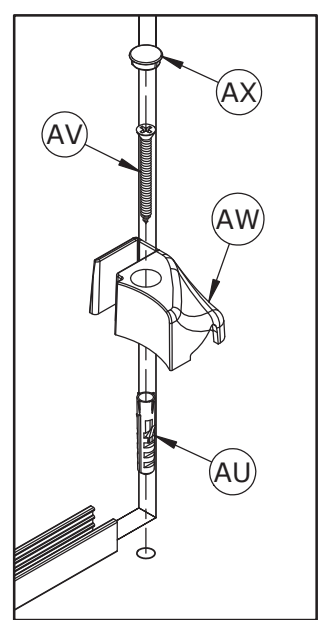
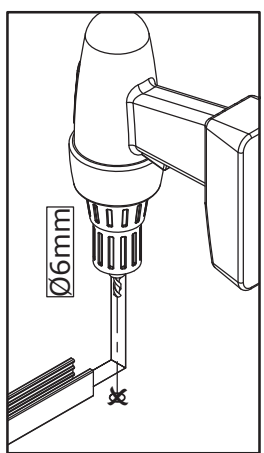
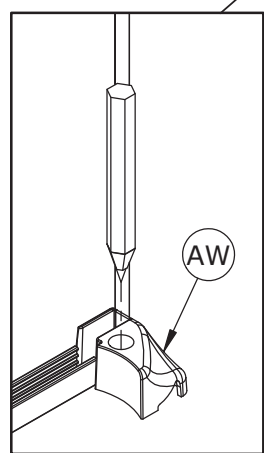
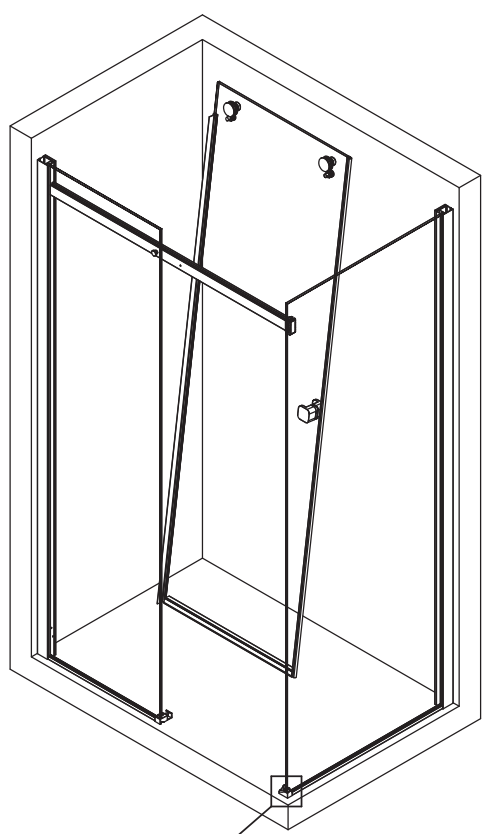

INTERIEUR - INTERNAL - INTERNO - BINNENZIJDE - INTERNO - INNEN

17

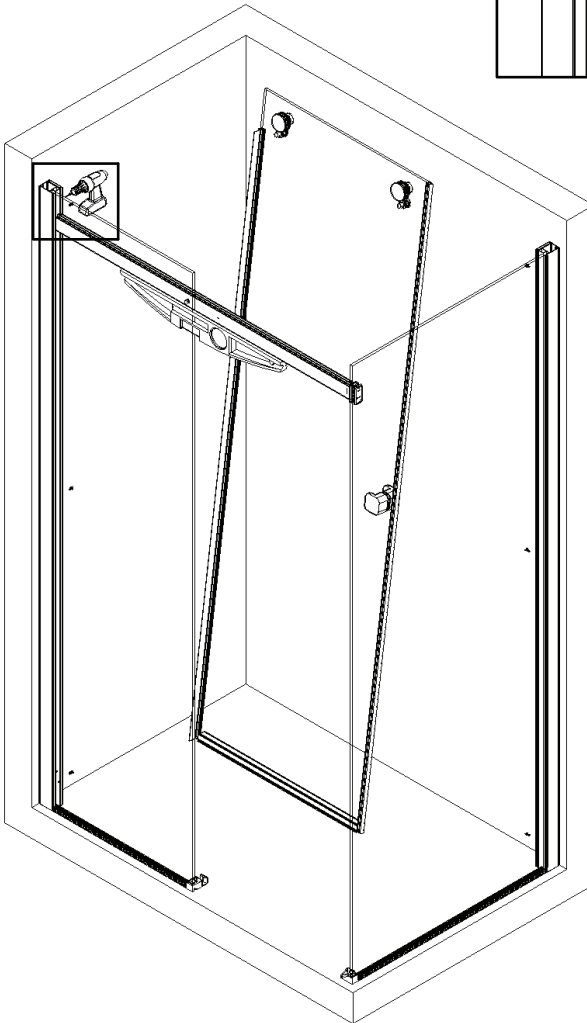
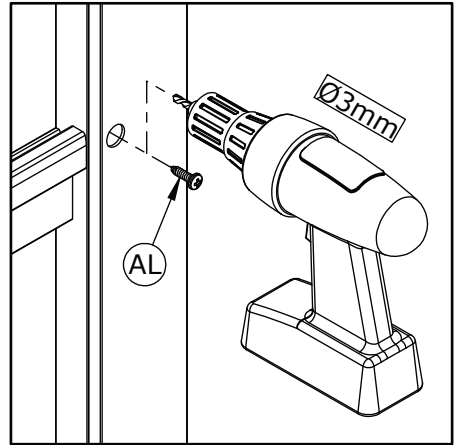
X6

18

2

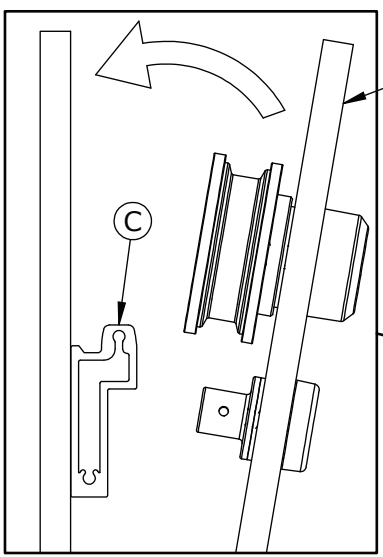

F

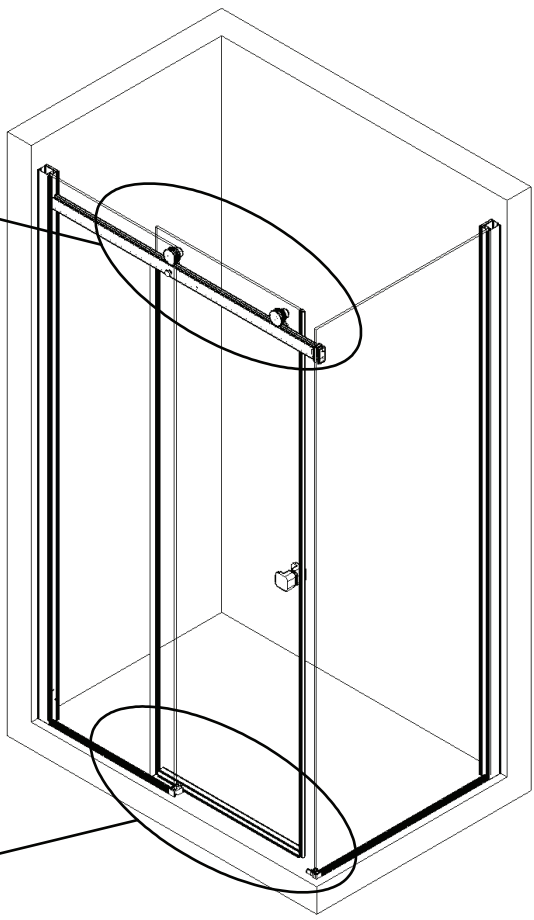

1

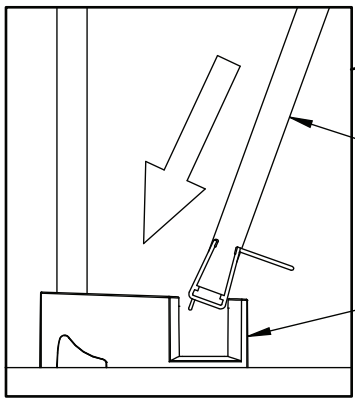

F

AT

19

Régler la porte
Adjust the door
Regolare le porte
Stel de deuren
Ajustar la puerta
Tür einstellen

1

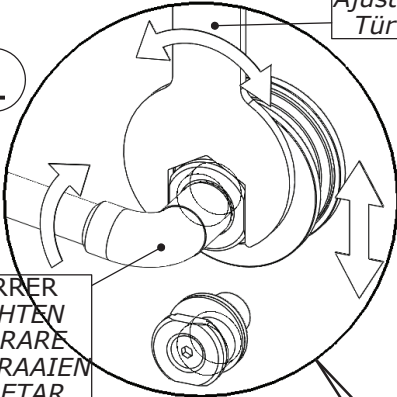

2

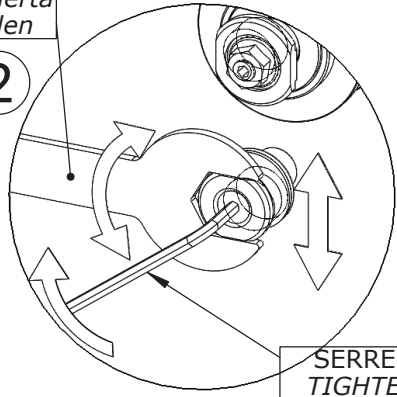

SERRER
TIGHTEN
SERRARE
AANDRAAIEN
APRETAR
FESTZIEHEN

SERRER
TIGHTEN
SERRARE
AANDRAAIEN
APRETAR
FESTZIEHEN

3

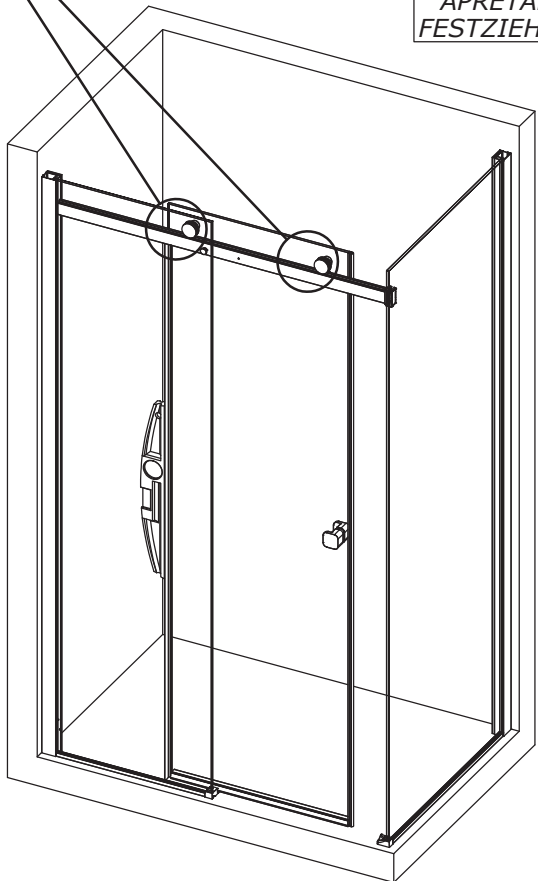
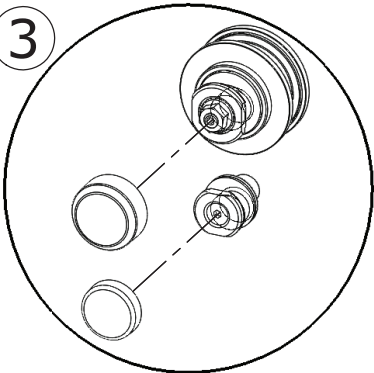

AK

AL

MIN 0,5mm
MAX 2mm

E

20

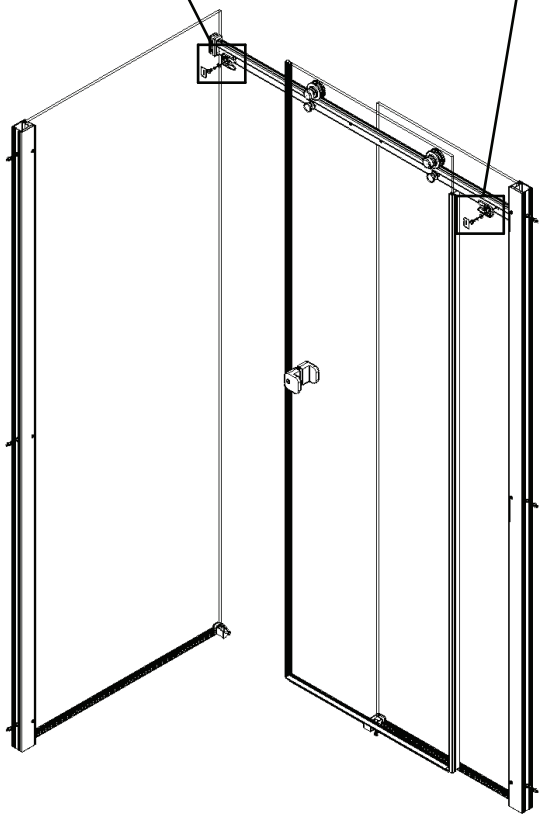
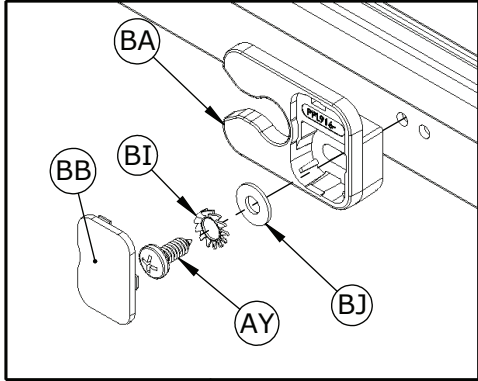
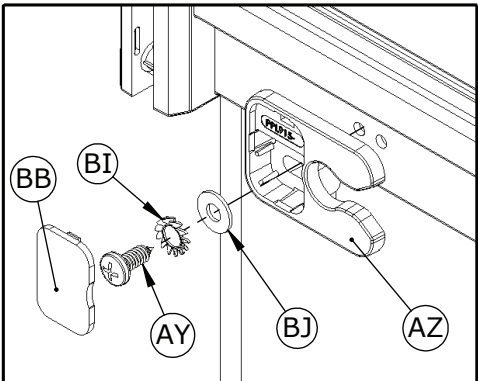

(21)

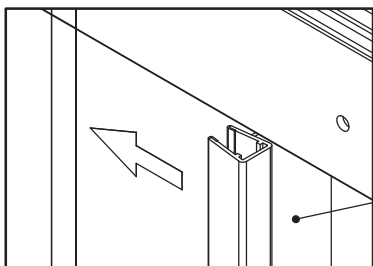

BC

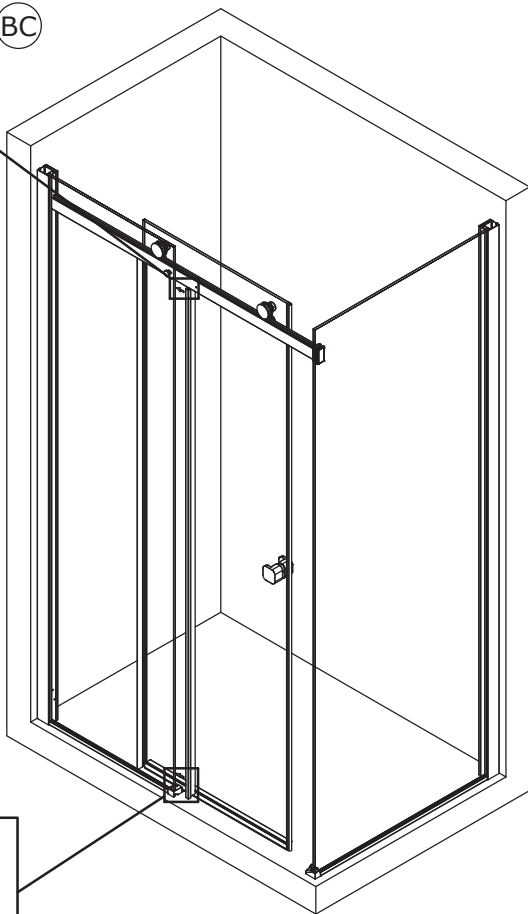
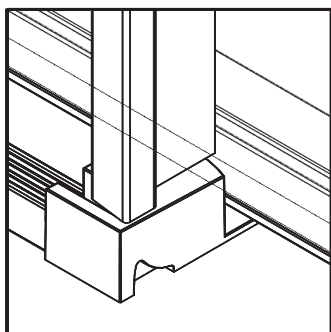
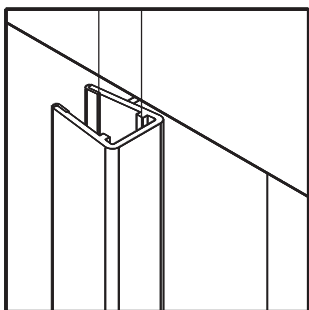

BC

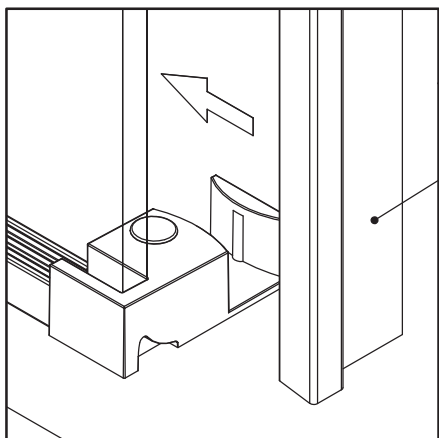

EXTERIEUR
EXTERNAL
ESTERNO
BUITENZIJD
EXTERNO
AUBEN

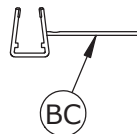

BC

INTERIEUR
INTERNAL
INTERNO
BINNENZIJD
INTERNO
INNEN

22

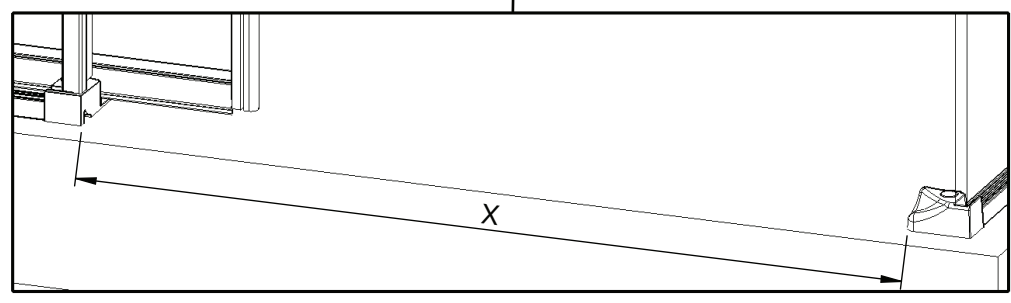
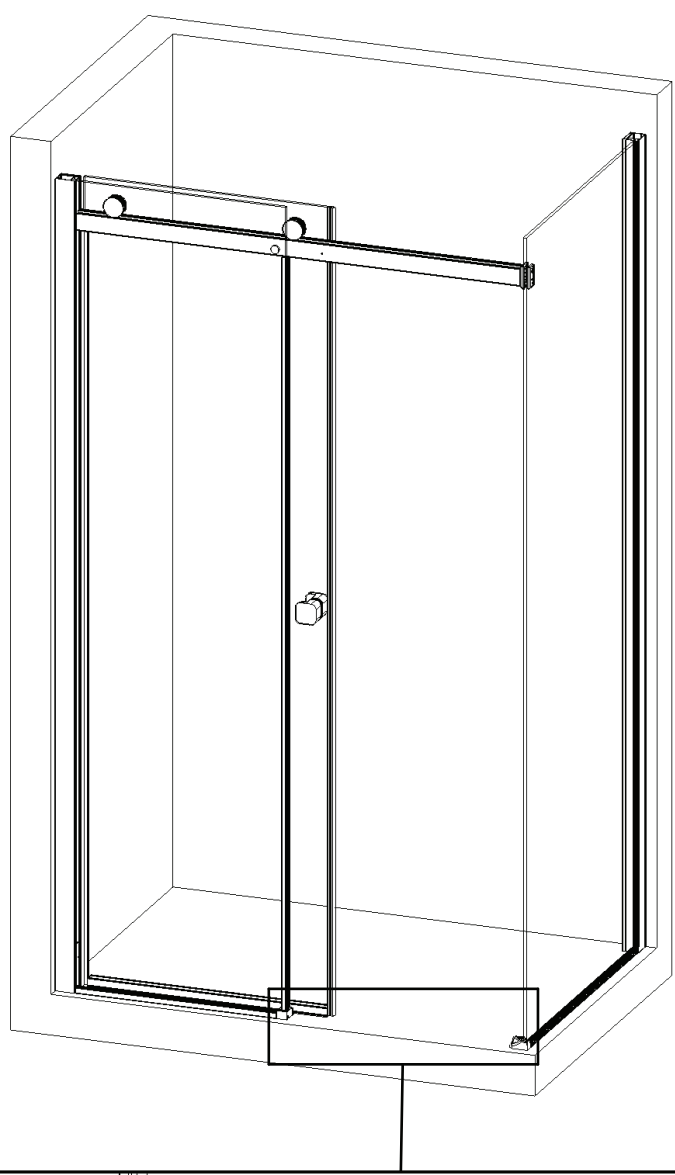

23

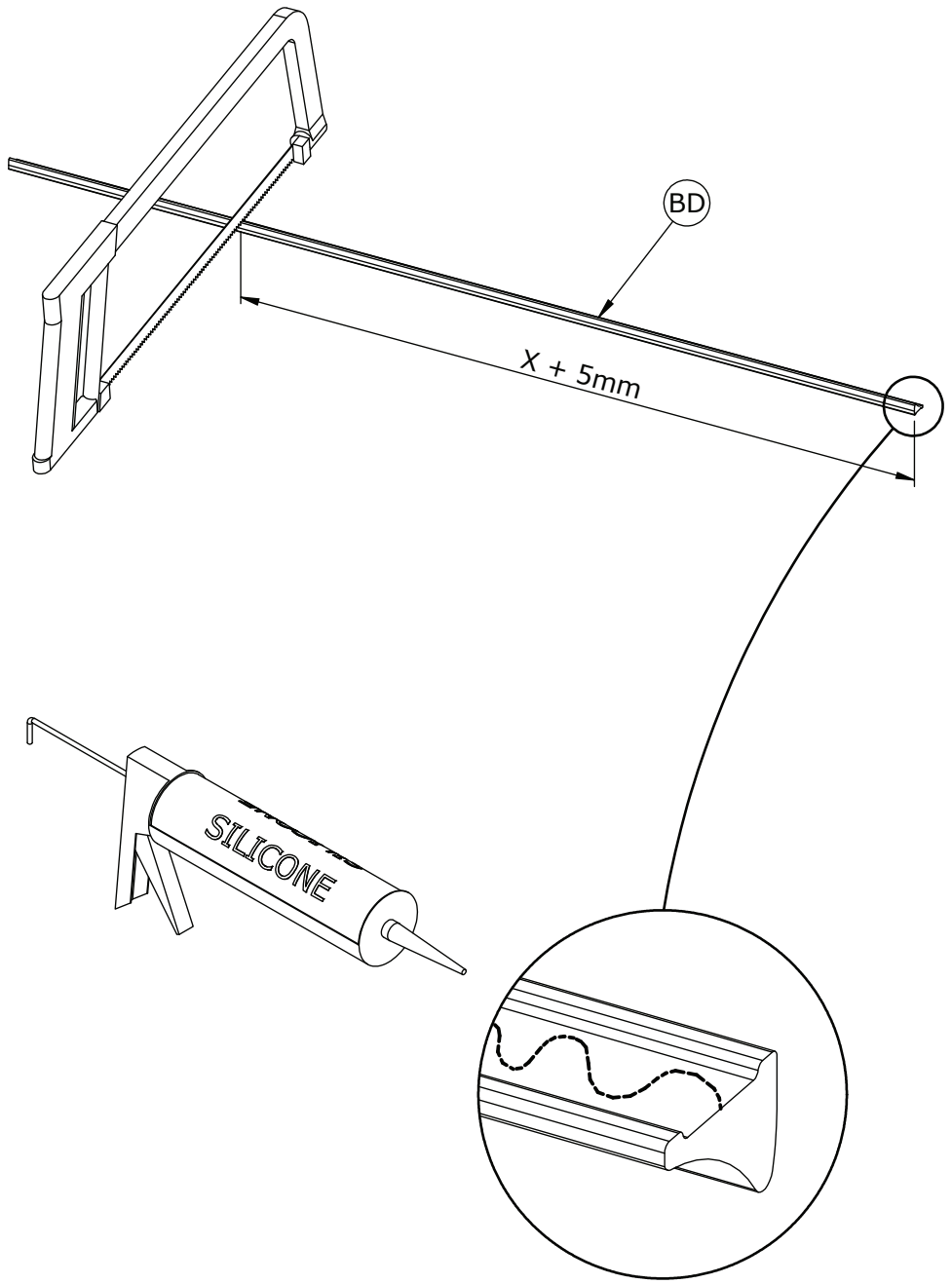

24

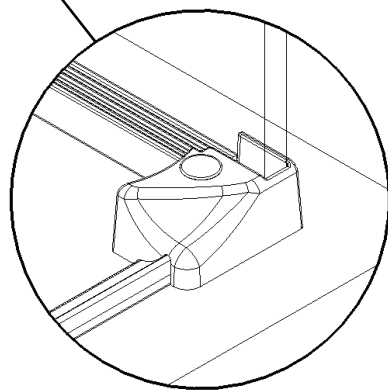
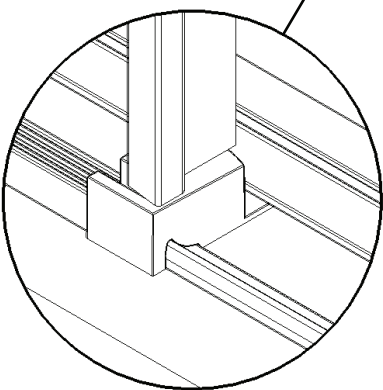
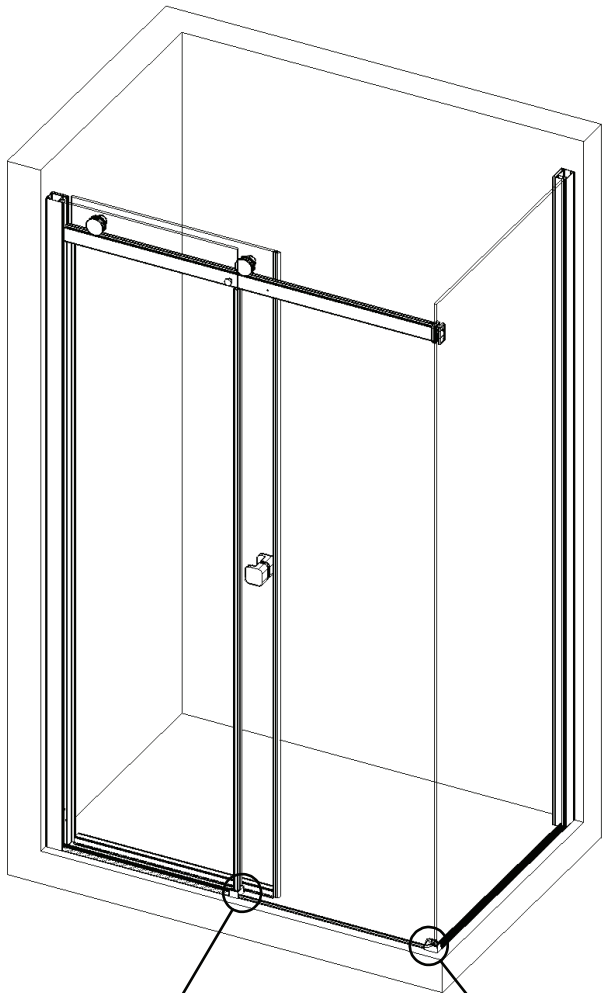

25

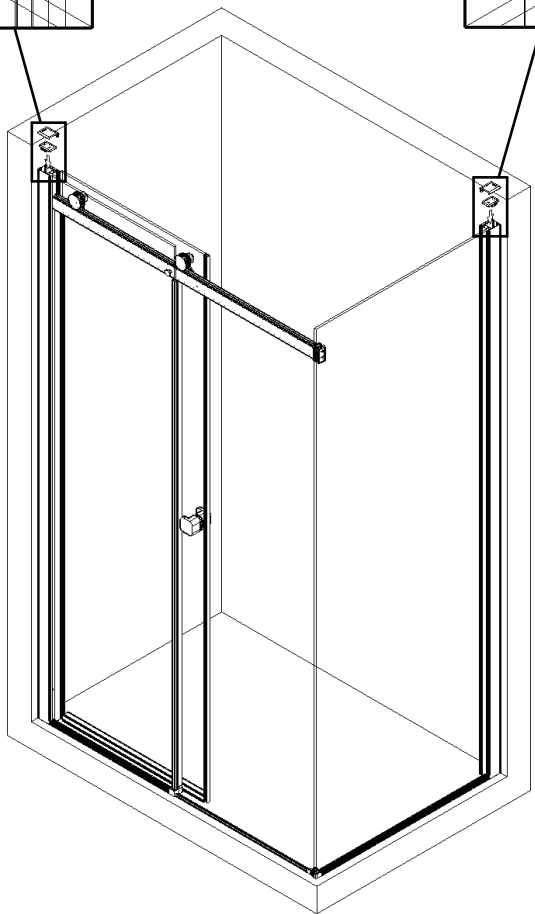
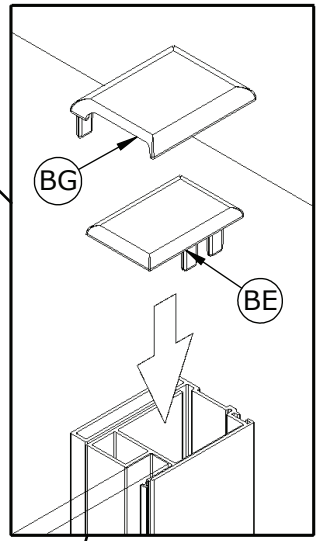
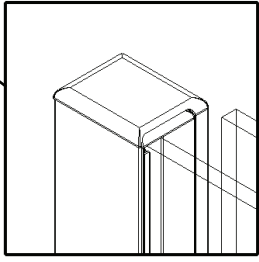
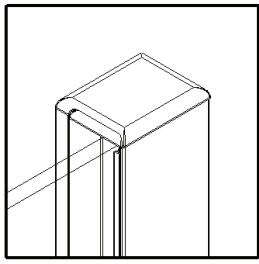
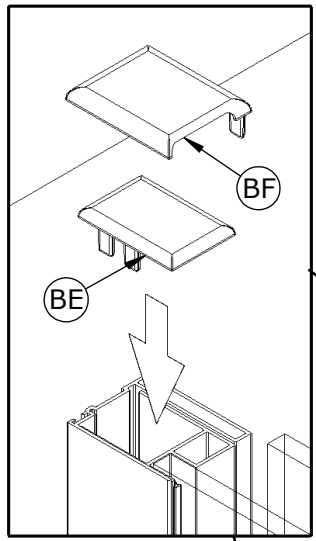

26

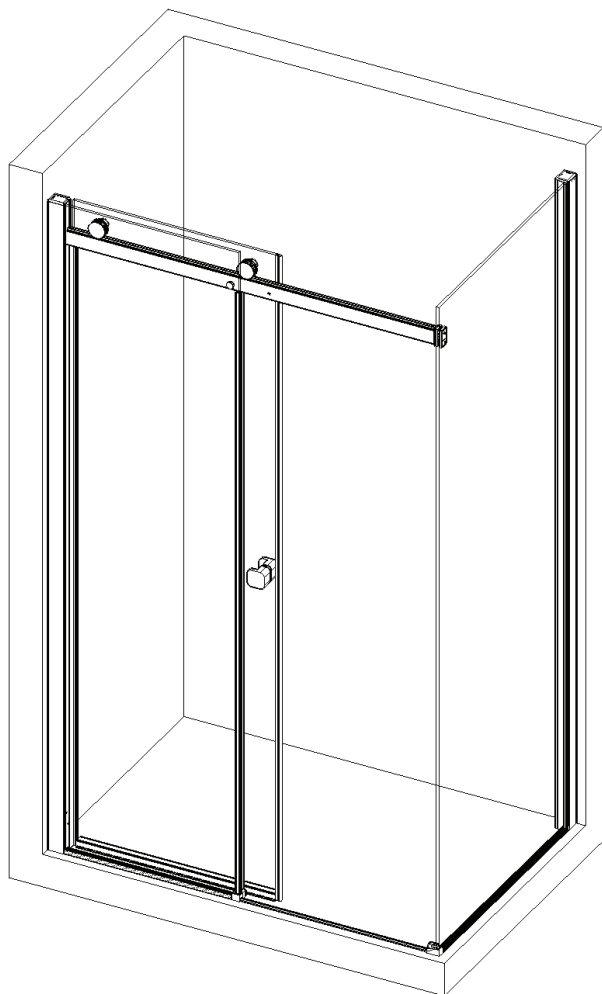

X5

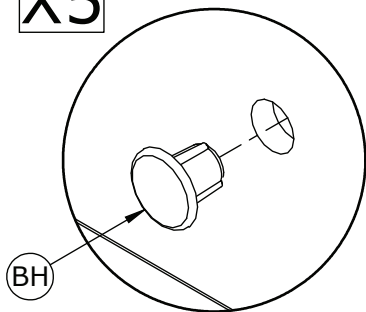

X6

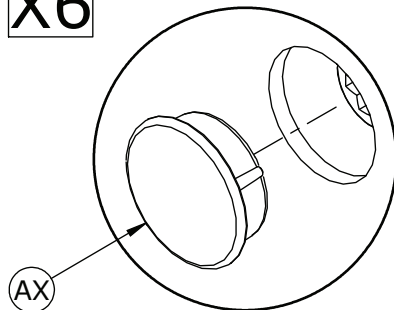

27

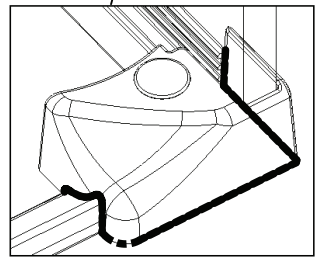
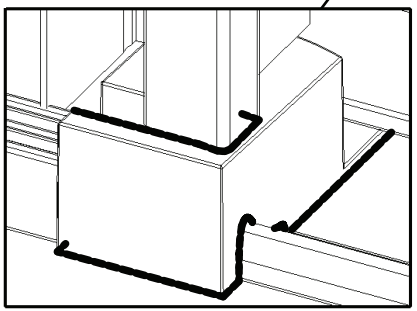
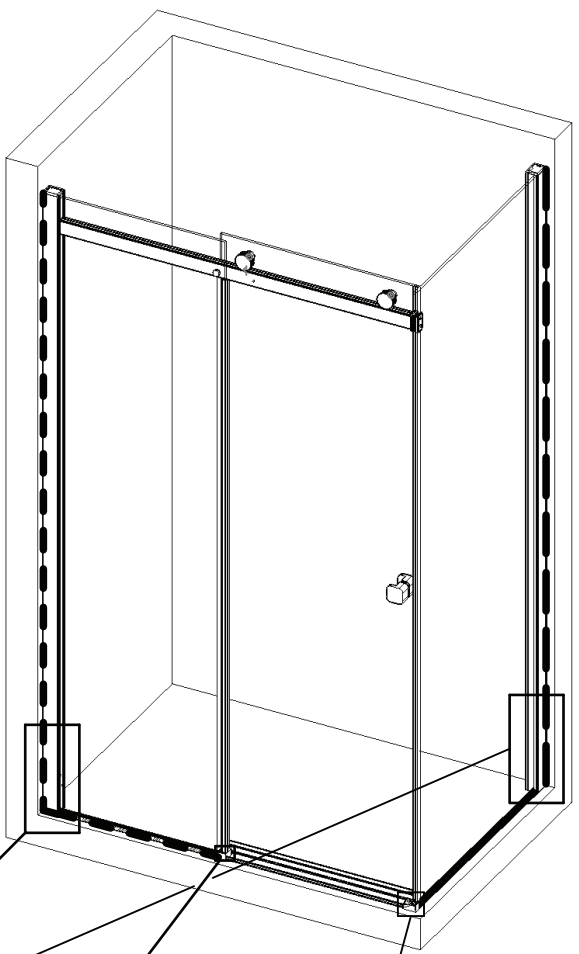
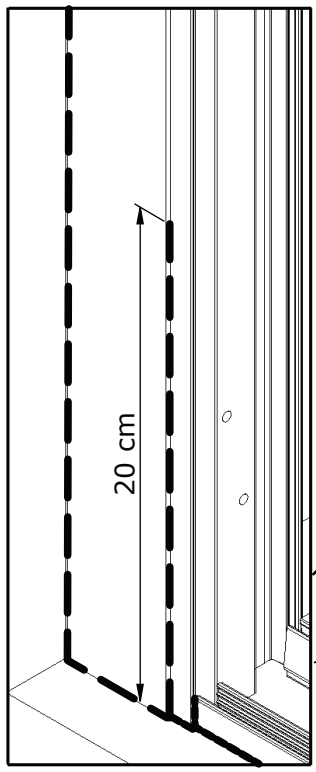
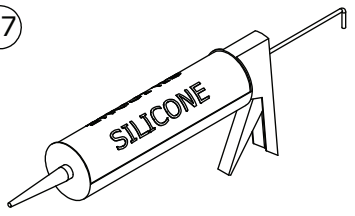

SEQUENCE DE MONTAGE - ASSEMBLY SEQUENCE - SEQUENZA DI MONTAGGIO
 MONTAGEVOLGORDE - SECUENCIA DE MONTAJE - MONTAGEREIHENFOLGE

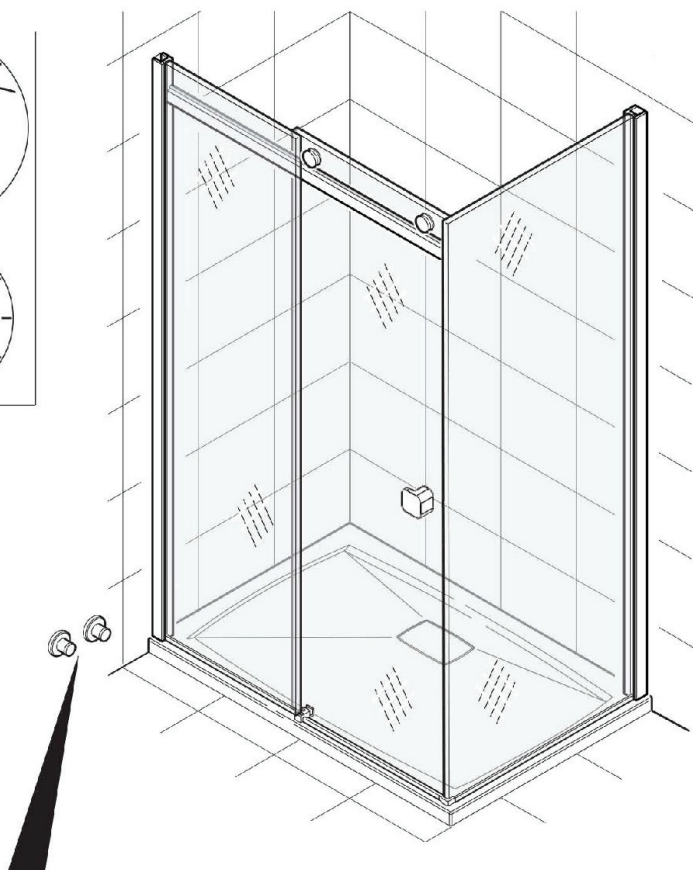
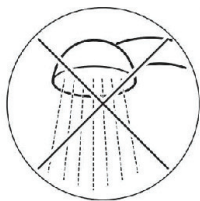

Chaude
Hot
Calda
Warm
Caliente
Warm

Froide
Cold
Fredda
Koud
Fría
Kalt

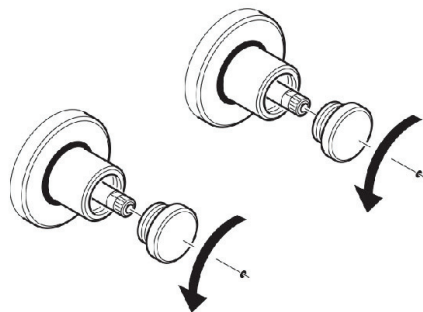
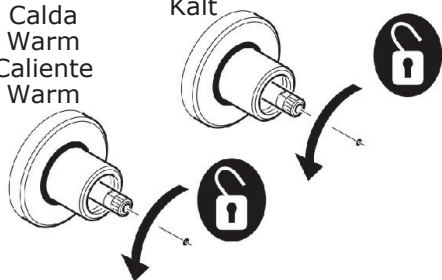

Informations sur l'utilisation
Useful information
Informazioni sull'utilizzo
Informatie over het gebruik
Informaciones sobre el uso
Informationen über die Verwendung

Ne pas mettre les mains entre les parois de verre lorsque celles-ci sont coulissées.

Do not put your hands between the glass walls when they are sliding

Non mettere le mani tra le pareti in vetro mentre scorrono.

Steek uw handen niet tussen de glazen wanden wanneer deze worden verschoven.

No ponga las manos entre los cristales mientras se desplazan.

Legen Sie Ihre Hände nicht zwischen die Glaswände während diese geschoben werden.

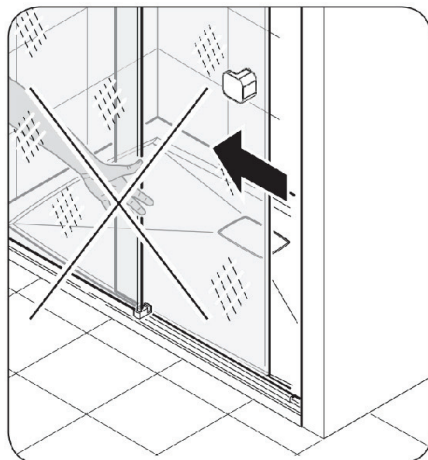

Ne pas s'accrocher à la fermeture de la douche.

Do not hold onto the shower door.

Non aggrapparsi alla chiusura doccia.

Ga niet aan de douchesluiting hangen.

No agarrarse al cierre de la ducha.

Nicht an der Duschkabinentür festhalten.

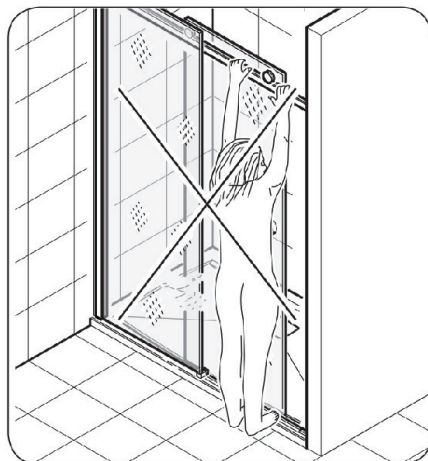

Informations sur l'utilisation
Useful information
Informazioni sull'utilizzo
Informatie over het gebruik
Informaciones sobre el uso
Informationen über die Verwendung

Ne pas suspendre d'objet lourds à la fermeture de la douche.

Do not hang heavy objects on the shower door.

Non appendere oggetti pesanti alla chiusura doccia.

Hang geen voorwerpen aan de douchesluiting.

No colgar objetos pesados en la ducha.

Keine schweren Gegenstände an die Duschkabinentür hängen.

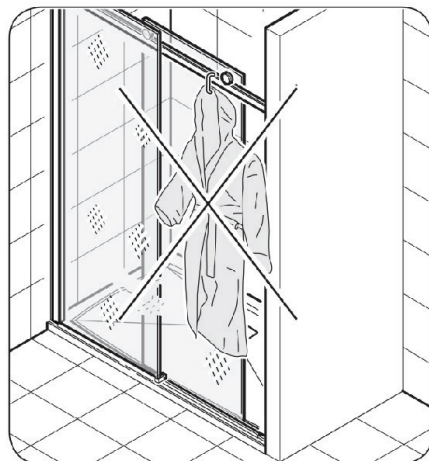

Nettoyer périodiquement le profilé de coulissement et régler périodiquement les roulettes.

Periodically clean the sliding profile and periodically adjust the rollers.

Pulire il profilo di scorrimento e regolare le rotelle periodicamente.

Reining het geleiderprofiel en stel de wieltjes regelmatig af.

Limpiar el perfil de deslizamiento y regular las ruedas periódicamente.

Reinigen Sie das Führungsprofil regelmäßig und stellen Sie die Gleitrollen regelmäßig ein

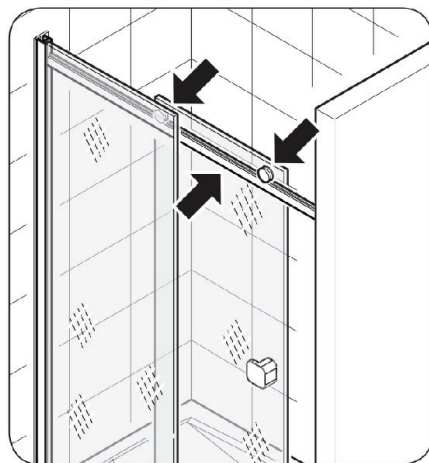

Nettoyage et entretien
Cleaning and maintenance
Pulizia e manutenzione
Reinigen en onderhoud
Limpieza y mantenimiento
Reinigung und wartung

Nettoyage des parties chromées
Cleaning chrome parts
Pulizia delle parti cromate
Reinigen van de verchromde onderdelen
Limpieza de las partes cromadas
Reinigung der verchromten Teile

- Pour nettoyer les surfaces chromées, utiliser **UNIQUEMENT** des détergents liquides neutres.
 Pour obtenir des surfaces brillantes, appliquer périodiquement une pâte à polir sur un chiffon.

 Ne pas utiliser de détergents, de produits abrasifs, d'alcool, de diluants, de substances corrosives ou autres solvants.

- To clean chrome surfaces, use **ONLY** neutral liquid detergents.
 To obtain shiny surfaces, periodically apply normal polish on a cloth.

 Do not use detergents, abrasive products, alcohol, thinners, corrosive substances or other solvents.

- Per la pulizia delle superfici cromate utilizzare **SOLO** detersivi liquidi neutri.
 Per mantenere lucide le superfici, utilizzare periodicamente un panno e del normale polish.

 Non utilizzare detersivi o materiali abrasivi, alcool, diluenti, sostanze corrosive o altri solventi.

- Gebruik voor het reinigen van verchromde oppervlakken **ALLEEN** neutrale reinigingsmiddelen.
 Om de verchromde oppervlakken glanzend te houden, gebruik regelmatig een doek en conventioneel schoonmaakmiddel.

 Gebruik geen schoonmaakmiddelen of schurende materialen, alcohol, verdunners, oplosmiddelen of andere bijtende stoffen.

- Para la limpieza de las superficies cromadas utilizar **ÚNICAMENTE** detergentes líquidos neutros.
 Para mantener lúcidas las superficies, utilizar periódicamente un paño y un pulimento normal.

 No utilizar detergentes ni materiales abrasivos, alcohol, diluyentes, sustancias corrosivas ni otros disolventes.

- Für die Reinigung verchromter Oberflächen sind **AUSSCHLIESSLICH** neutrale Flüssigreiniger zu verwenden.
 Oberflächen bleiben glänzend, wenn sie regelmäßig mit einem weichen Tuch und Politur gepflegt werden.

 Keine Waschmittel, Scheuermittel, Alkohol, Verdünnungsmittel, ätzende Substanzen oder andere Lösungsmittel verwenden.

Nettoyage et entretien
Cleaning and maintenance
Pulizia e manutenzione
Reinigen en onderhoud
Limpieza y mantenimiento
Reinigung und wartung

Nettoyage des vitres
Glass cleaning
Pulizia del cristalli
Reinigen van het gals
Limpieza de los cristales
Reinigung der Scheiben

- Il est conseillé de nettoyer périodiquement de manière approfondie les vitres fixes et la porte.
 - Nettoyage journalier
Rincer abondamment à l'eau froide puis essuyer avec une raclette.
 - Nettoyage périodique
Nettoyer régulièrement à l'aide d'une éponge non-abrasive et de vinaigre blanc, puis essuyer avec un chiffon doux.

 Pour déposer la porte ou la vitre fixe, procéder à l'inverse de la procédure illustrée dans ce manuel.

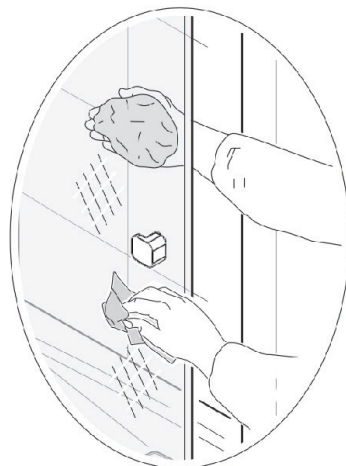

- It is advisable to thoroughly clean the fixed glass and door periodically.
 - Daily cleaning
Rinse thoroughly with cold water the wipe with a squeegee.
 - Periodic cleaning
Clean regularly using a non-abrasive sponge and white vinegar, then wipe with a soft cloth.

 To remove the door or fixed glass, reverse the procedure illustrated in this manual.

- Periodicamente si consiglia di effettuare un'accurata pulizia dei cristalli fissi e della porta.
 - Pulizia giornaliera
Risciacquare abbondantemente con acqua fredda e asciugare con una racla in gomma.
 - Pulizia periodica
Pulire regolarmente con una spugna non abrasiva e dell'aceto bianco, quindi asciugare con un panno morbido.

 Se dovesse essere necessario rimuovere la porta o il cristallo fisso, operare in senso inverso a quanto illustrato nel presente manuale.

Nettoyage et entretien
Cleaning and maintenance
Pulizia e manutenzione
Reinigung en onderhoud
Limpeza y mantenimiento
Reinigung und wartung

- Het is raadzaam de glazen wanden en deruren regelmatig en zorgvuldig te reinigen.
 - Dagelijkse schoonmaak
Rijkelijk afspoelen met koud water en vervolgens schoonvegen met een raamwisser.
 - Periodieke reiniging
Schoonmaken met behulp van een niet-schurende spons en met schoonmaak-schoonmaak azijn, daarna schoonvegen en afdrogen met een zachte doek.

 Als u de deur of het vaste glas dient te verwijderen, ga dan omgekeerd te werk t.o.v. wat is aangegeven in deze handleiding.

- Periódicamente, se aconseja realizar una limpieza precisa de los cristales fijos y de la puerta.

Para la limpieza, utilizar detergentes comunes para vidrios y cristales.

- Limpeza diaria
Aclarar abundantemente con agua fría y secar con una rasqueta.
- Limpeza periodica
Limpiar con una esponja suave o una bayeta y con vinagre blanco y secar con una gamuza.

 Si fuese necesario quitar la puerta o el cristal fijo, opere en sentido inverso a lo ilustrado en este manual.

- Es wird empfohlen, die festen Scheiben und die Tür regelmäßig gründlich zu reinigen.
 - Tägliche Reinigung
Mit kaltem Wasser gut abspülen und anschließend mit einem Gummiwischer abziehen.
 - Regelmäßige Reinigung
Regelmäßig mit einem nicht scheuernden Schwamm und weißem Essig reinigen und anschließend mit einem weichen Tuch trocken wischen.

 Das abnehmen der Tür oder der festen Scheiben erfolgt nachdem in diesem Handbuch gezeigten Verfahren in umgekehrter Reihenfolge.





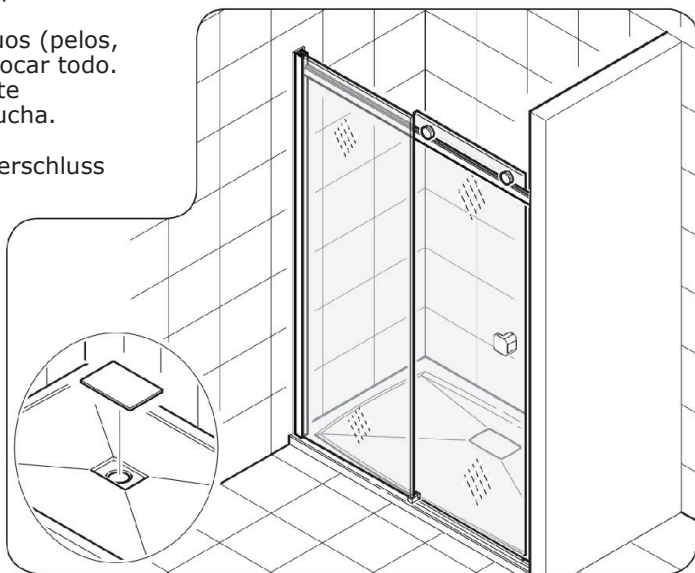

Nettoyage et entretien
Cleaning and maintenance
Pulizia e manutenzione
Reinigen en onderhoud
Limpieza y mantenimiento
Reinigung und wartung

Nettoyage de la bonde
Cleaning the waste
Pulizia piletta di scarico
Reinigen van douche-afvoer
Limpieza del desagüe
Reinigung des Bodenablaufs

- Retirer périodiquement le bouchon de la bonde de vidage et vérifier que le bol placé en dessous soit propre.
 Eliminer d'éventuels résidus (cheveux, fils, etc...) et remettre en place.
 Selon le modèle, reportez-vous au manuel du receveur.
- Periodically remove the cover from the waste and check that the waste is clean underneath. Remove any residue (hair, threads etc.) and replace.
 Depending on the model, refer to the shower tray manual.
- Periodicamente rimuovere il tappo della piletta di scarico e controllare che il bicchiere sottostante sia pulito.
 Rimuovere eventuali residui (peli, fili, etc) e riposizionare il tutto.
 A seconda del modello, consultare il manuale del piatto doccia.
- Verwijder regelmatig het dekseltje van de douche-afvoer en controleer of het onderliggende vaatje schoon is.
 Verwijder eventuele resten (haren, draden, enz.) en plaats alle onderdelen terug.
 Afhankelijk van het model, zie de handleiding van de douchebak.
- Periódicamente, quitar el embellecedor del desagüe y controlar que el vaso del desagüe esté limpio.
 Quitar los posibles residuos (pelos, hilos, etc.) y volver a colocar todo.
 Según el modelo, consulte el manual del plato de ducha.
- Regelmäßig den Ablaufverschluss entfernen und den Einsatz auf Verschmutzungen überprüfen.
 Eventuelle Rückstände entfernen (Haare, Fasern usw.) und Verschluss wieder einsetzen.
 Weitere Informationen zum jeweiligen Modell finden Sie im Handbuch zur Duschwanne.





<p>FR</p> <p>Bon de garantie</p> <p>SCANNEZ MOI</p>  <p>http://tiny.cc/bon-de-garantie-fr</p>	<p>GB</p> <p>Guarantee</p> <p>SCAN ME</p>  <p>http://tiny.cc/bon-de-garantie-gb</p>
<p>DE</p> <p>Garantiekarte</p> <p>SCAN MICH</p>  <p>http://tiny.cc/bon-de-garantie-de</p>	<p>NL</p> <p>Garantievoorwaarden</p> <p>SCAN MIJ</p>  <p>http://tiny.cc/bon-de-garantie-nl</p>
<p>ES</p> <p>Garantía</p> <p>ESCANÉAME</p>  <p>http://tiny.cc/bon-de-garantie-es</p>	<p>IT</p> <p>Garanzia</p> <p>SCANSIONAMI</p>  <p>http://tiny.cc/bon-de-garantie-it</p>
<p>PT</p> <p>Garantia</p> <p>ESCANIEI-ME</p>  <p>http://tiny.cc/bon-de-garantie-pt</p>	<p>CH</p> <p>Garantiekarte</p> <p>SCAN MICH</p>  <p>http://tiny.cc/bon-de-garantie-ch</p>
<p>BE</p> <p>Garantievoorwaarden</p> <p>SCAN MIJ</p>  <p>http://tiny.cc/bon-de-garantie-be</p>	<p>AT</p> <p>Garantiekarte</p> <p>SCAN MICH</p>  <p>http://tiny.cc/bon-de-garantie-at</p>



Kinedo

FR

Conseils
d'entretien

SCANNEZ MOI



<http://tiny.cc/conseils-entretien-fr>

GB

Maintenance
instructions

SCAN ME



<http://tiny.cc/conseils-entretien-gb>

DE

Wartungstipps

SCAN MICH



<http://tiny.cc/conseils-entretien-de>

NL

Onderhoudstips

SCAN MIJ



<http://tiny.cc/conseils-entretien-nl>

ES

Consejos de
mantenimiento

ESCANÉAME



<http://tiny.cc/conseils-entretien-es>

IT

Consigli per la
manutenzione

SCANSONAMI



<http://tiny.cc/conseils-entretien-it>

PT

Dicas de
manutenção

ESCANIEI-ME



<http://tiny.cc/conseils-entretien-pt>

CH

Wartungstipps

SCAN MICH



<http://tiny.cc/conseils-entretien-ch>

BE

Onderhoudstips

SCAN MIJ



<http://tiny.cc/conseils-entretien-be>

AT

Wartungstipps

SCAN MICH



<http://tiny.cc/conseils-entretien-at>



AQUAPRODUCTION, Site industriel,
F - 44680 Chaumes-en-Retz

14

EN 14428

Paroi de douche, fabriquée en verre de silicate
sodo-calcique de sécurité trempé thermiquement

Aptitude au nettoyage : réussite

Résistance à l'impact/propriétés de fragmentation : réussite

Durabilité : réussite



SERVICE APRÈS-VENTE / AFTER-SALES SERVICE
 ASSISTENZA POST-VENDITA / DIENST NA VERKOOP
 ASISTENCIA POSTVENTA / KUNDENDIENST



CE

FRANCE

+33 (0)2 40 21 29 45

UK

+44 (0)20 8842 0033

IRELAND

+353 04697 33102

DEUTSCHLAND

+49 (0) 6074 / 30928 0

ITALIA

+39 02 30559420

ÖSTEREICH

+43 1 710 60 70

SUISSE/SCHWEIZ

+41 (0)32 631 04 74

ESPAÑA

+34 93 544 60 76

NEDERLAND

+31 475 487 100

BELGIQUE/BELGIË

+31 475 487 100

РОССИЯ

+7 495 258-29-51

PORTUGAL

+351 219 112 785