

Notice de montage
Installation instructions
Manual de instalación
Istruzioni di montaggio
Montage-instructies
Montageanleitung



Notre service technique est
à votre écoute aux numéros
qui sont au dos de cette
notice d'installation



Attention aux étapes :
Check installation steps :
Atención a los pasos :
Attenzione ai passi :
Aandacht voor de stappen :
Achtung vor den Schritten :



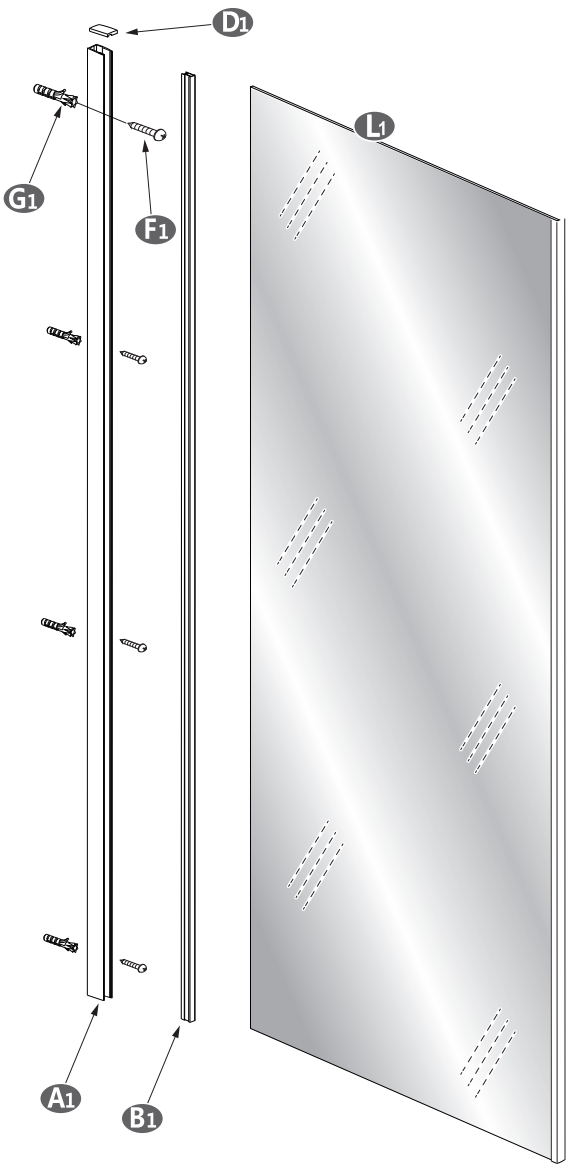

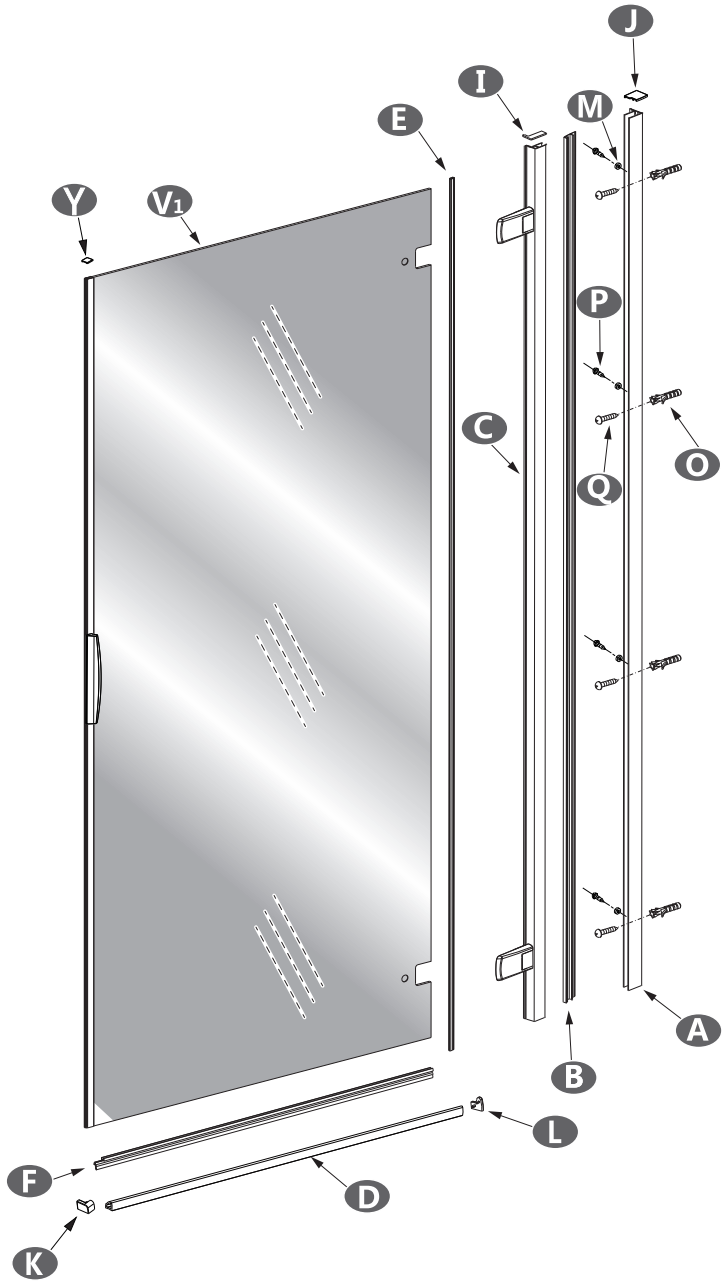



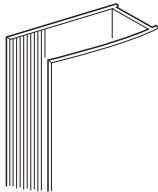
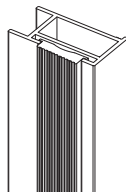
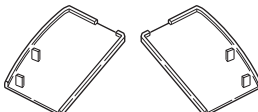
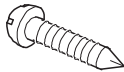
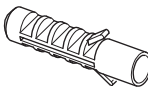
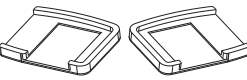

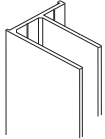
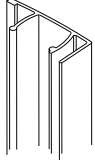
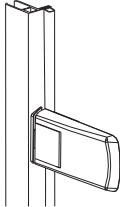
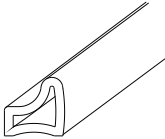
P. 9 - 11 - 31

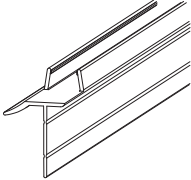
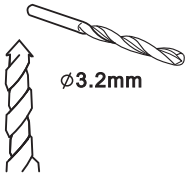
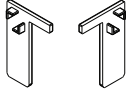
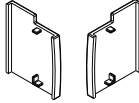

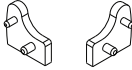

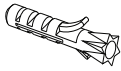

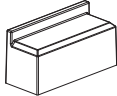
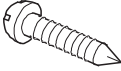
DES1371D

<p>(A1) x1</p>  <p>6346</p>	<p>(B1) x4</p>  <p>6347</p>	<p>(D1) x2</p>  <p>LX e RX SET160</p>
<p>(F1) x4</p>  <p>ST4x40</p>	<p>(G1) x4</p>  <p></p>	<p>(M1) x6</p>  <p></p>

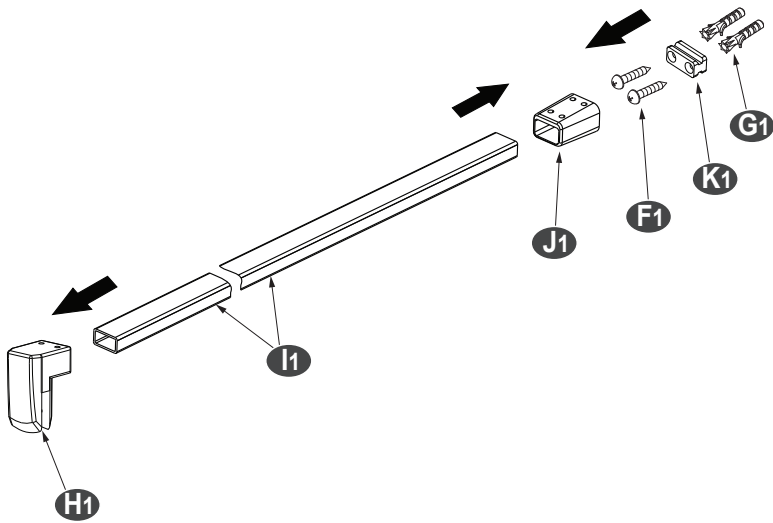
<p>(A) x1</p>  <p>6342</p>	<p>(B) x1</p>  <p>6343</p>	<p>(C) x1</p>  <p>6344E1 6344E2</p>
<p>(D) x1</p>  <p>6345</p>	<p>(E) x1</p>  <p>JOI324</p>	<p>(F) x1</p>  <p>JOI325</p>
<p>(G) x1</p>  <p>Ø3.2mm</p>	<p>(I) x2</p>  <p>SET156</p>	<p>(J) x2</p>  <p>SET157</p>
<p>(K) x2</p>  <p>SET158</p>	<p>(L) x2</p>  <p>SET159</p>	<p>(M) x4</p>  <p>ENT42</p>
<p>(O) x4</p> 	<p>(P) x4</p>  <p>ST4x12</p>	<p>(P1) x2</p>  <p>CAL133</p>
<p>(Q) x4</p>  <p>ST4x40</p>	<p>(Y) x1</p>  <p>PPL1354</p>	<p>(Z) x1</p>  <p>2.5mm</p>

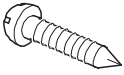
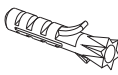
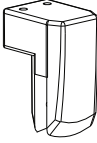
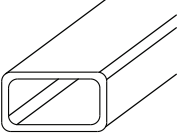

<p>(F1) x2</p>  <p>ST4x40</p>	<p>(G1) x2</p> 	<p>(H1) x1</p>  <p>SUP194</p>
<p>(I1) x1</p>  <p>6350</p>	<p>(J1) x2</p>  <p>SUP196</p>	<p>(K1) x1</p>  <p>SUP197</p>

Outils nécessaires (non fournis)
 Necessary tools (not supplied)
 Herramientas necesarias (no suministradas)
 Attrezzi necessari (non forniti)
 Erforderliches Werkzeug (wird nicht mitgeliefert)
 Benodigdheden (niet meegeleverd)

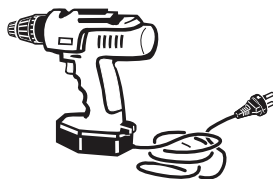
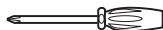
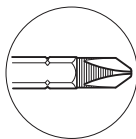
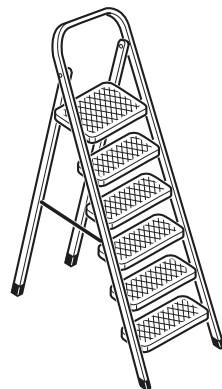
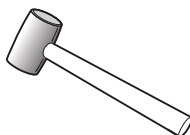
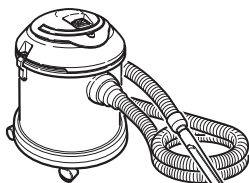
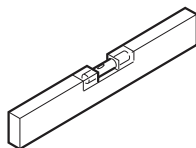
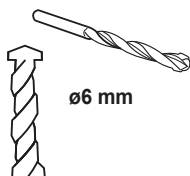
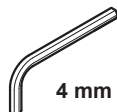

Réversibilité - Reversibility - Reversibilidad
Reversibilida - Omkeerbaarheid - Wahlweise Montage

Montage à gauche
Left hand
Montaje a la izquierda
Montaggio a sinistra
Montage links

Montage à droite
Right hand
Montaje a la derecha
Montaggio a destra
Montage rechts

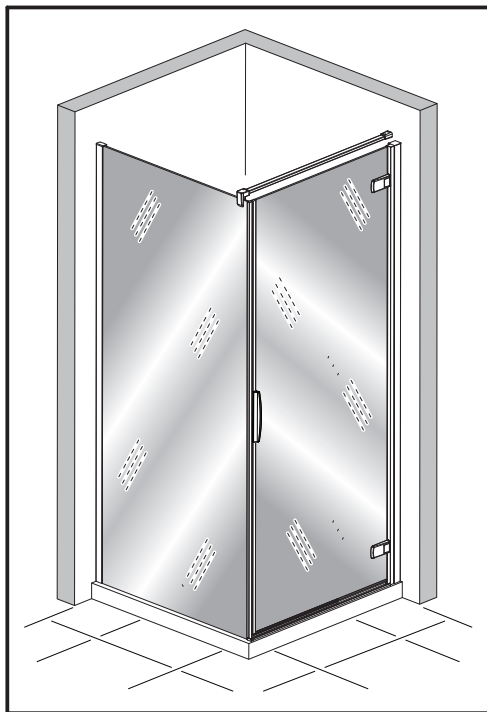
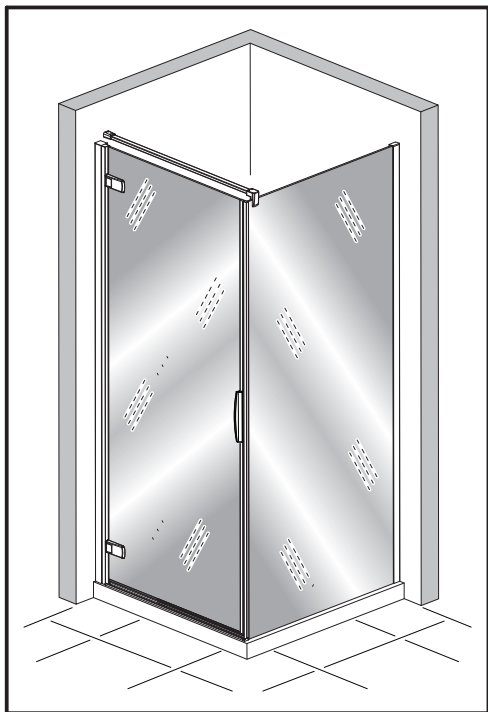

Vous avez la possibilité de réaliser un montage à droite ou un montage à gauche. Notre notice d'installation décrit un montage à droite. Si vous voulez réaliser un montage à gauche, il vous suffit d'inverser le montage.

This cubicle can be installed either left or right hand. These installation instructions show a right hand installation.

Puede realizar un montaje a la derecha o un montaje a la izquierda. Nuestro folleto de instalación describe un montaje a la derecha. Si desea montar su cabina a la izquierda sólo tendrá que realizar el montaje al contrario.

Avete la possibilità di effettuare il montaggio a destra o a sinistra. Il nostro manuale descrive il montaggio a destra. Se volete realizzare il montaggio a sinistra è sufficiente invertire varie fasi di montaggio.

U kunt de douchecabine rechts of links monteren. Onze handleiding beschrijft de rechts montage van de cabine. Keer de montage om als u de cabine links wilt monteren.

Sie haben die Möglichkeit, eine Montage auf der linken Seite oder eine Montage auf der rechten Seite durchzuführen. Unsere Montageanleitung beschreibt eine Montage auf der rechten Seite. Wenn Sie die Montage lieber auf der linken Seite durchführen wollen, müssen Sie nur den Montageprozess umkehren.

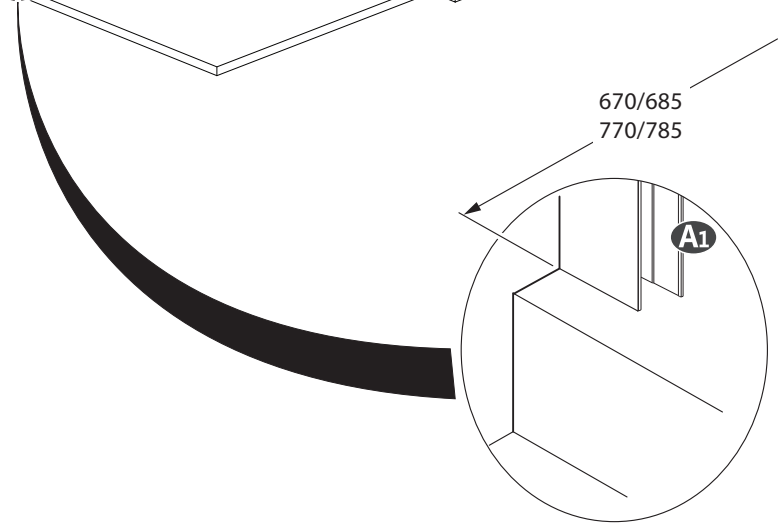
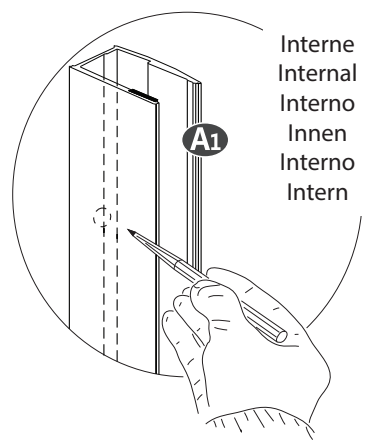
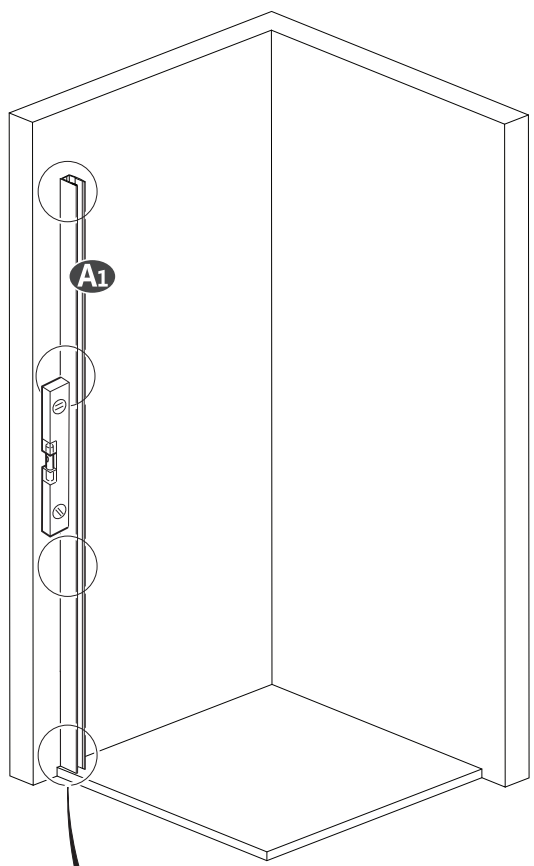

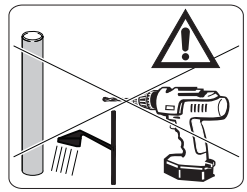
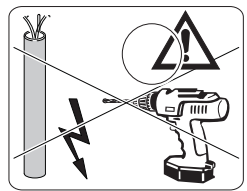
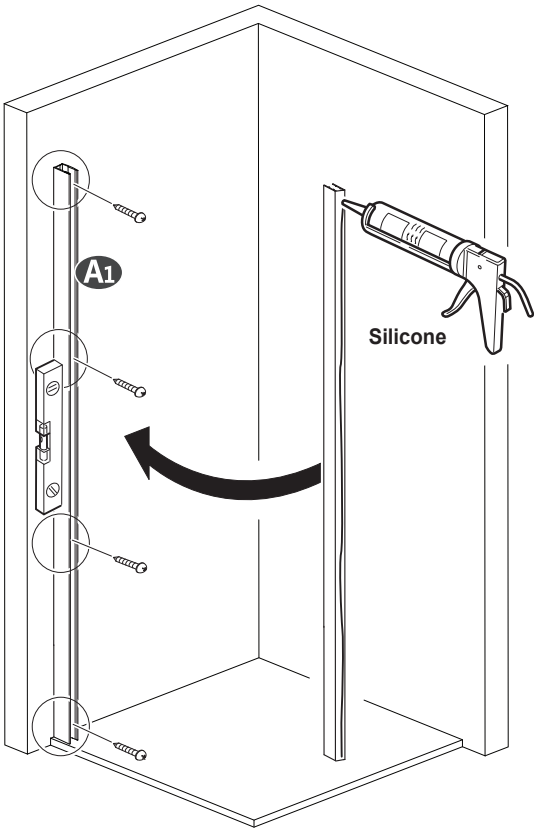
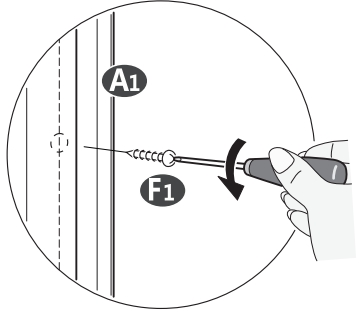
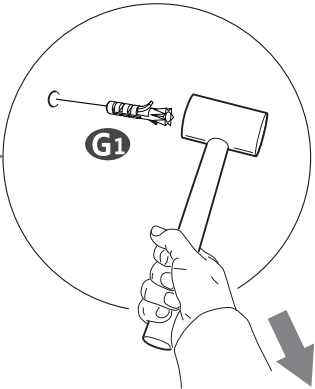
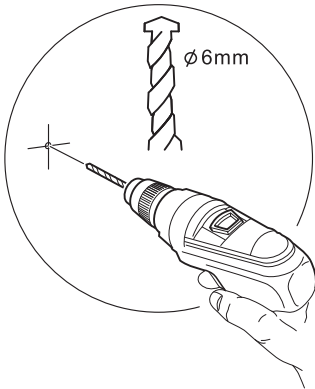

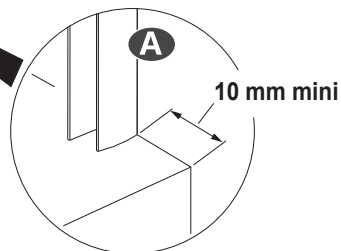
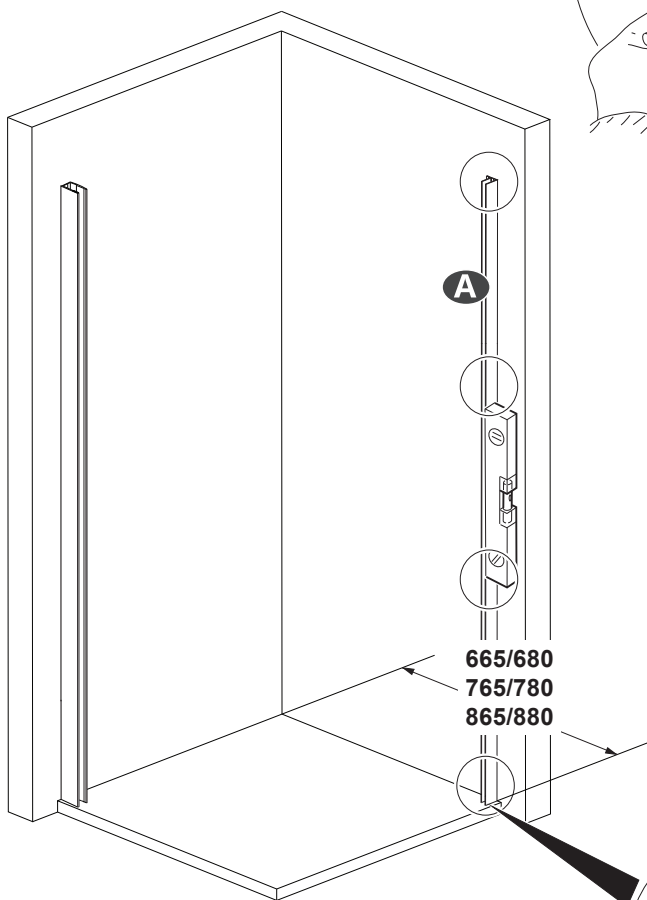
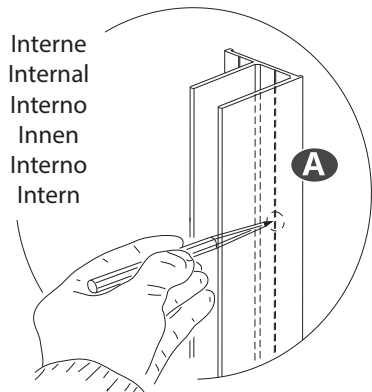

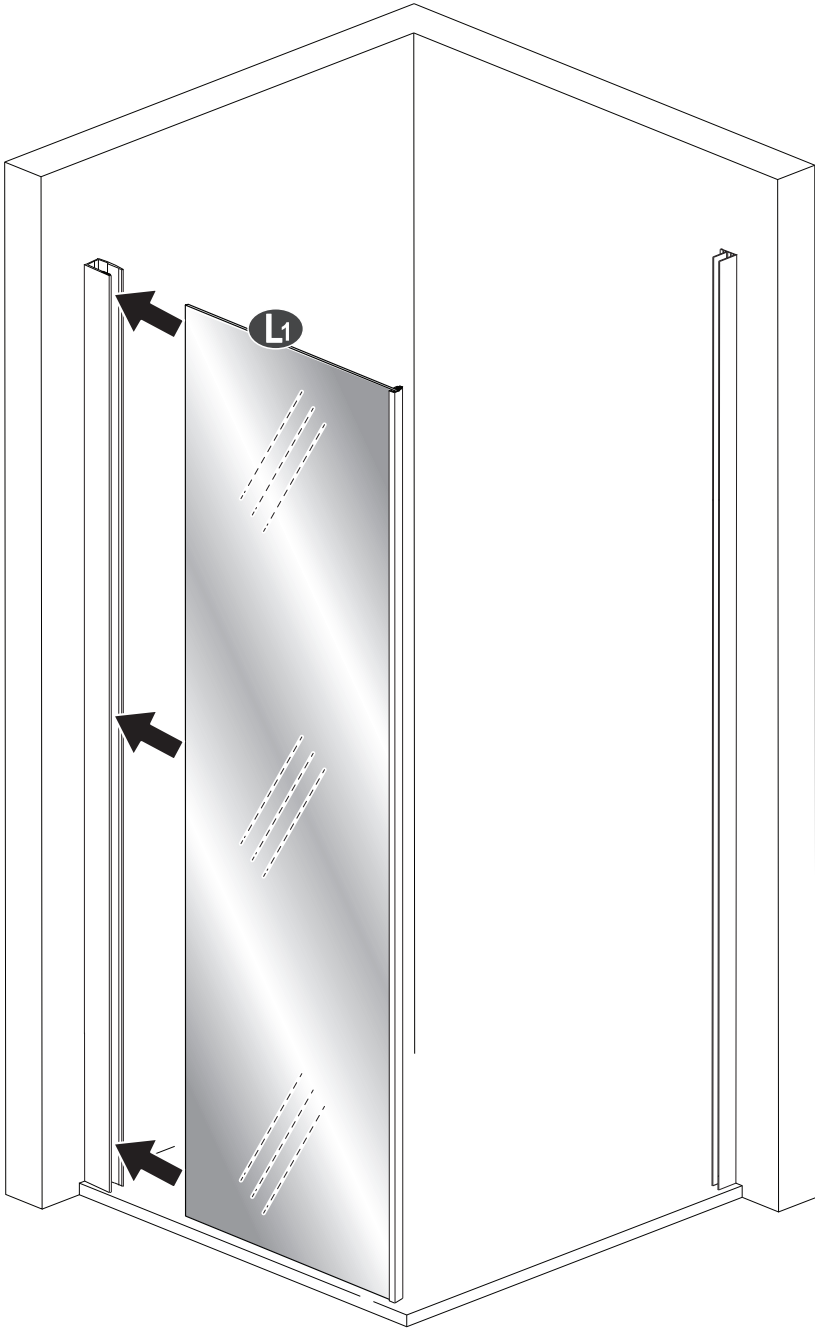

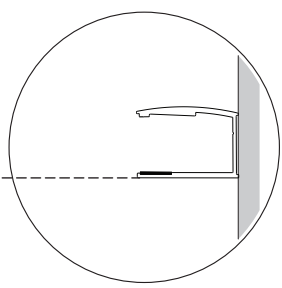
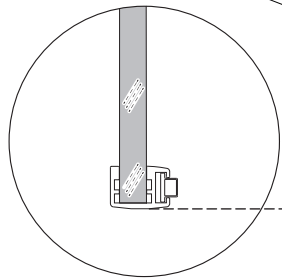
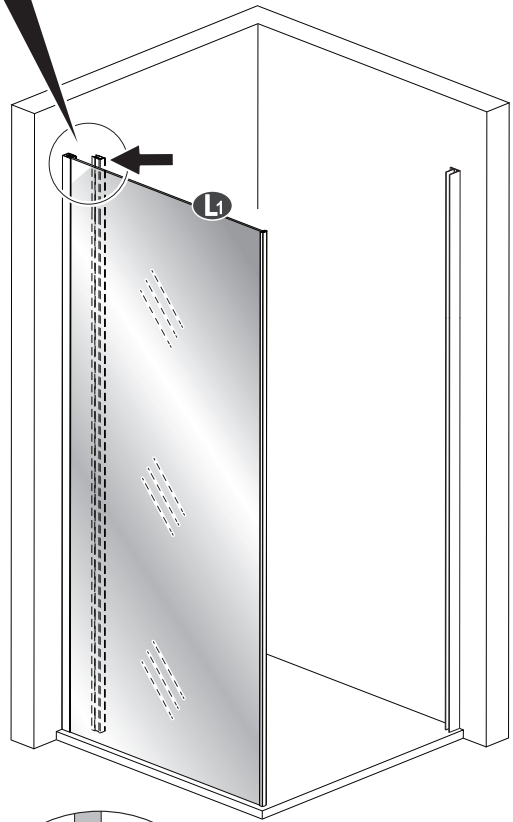
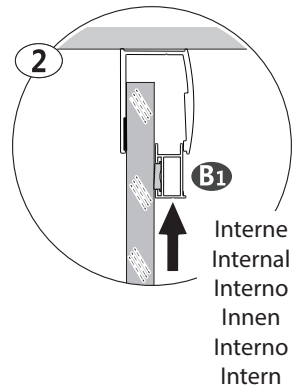
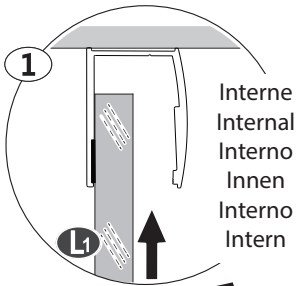

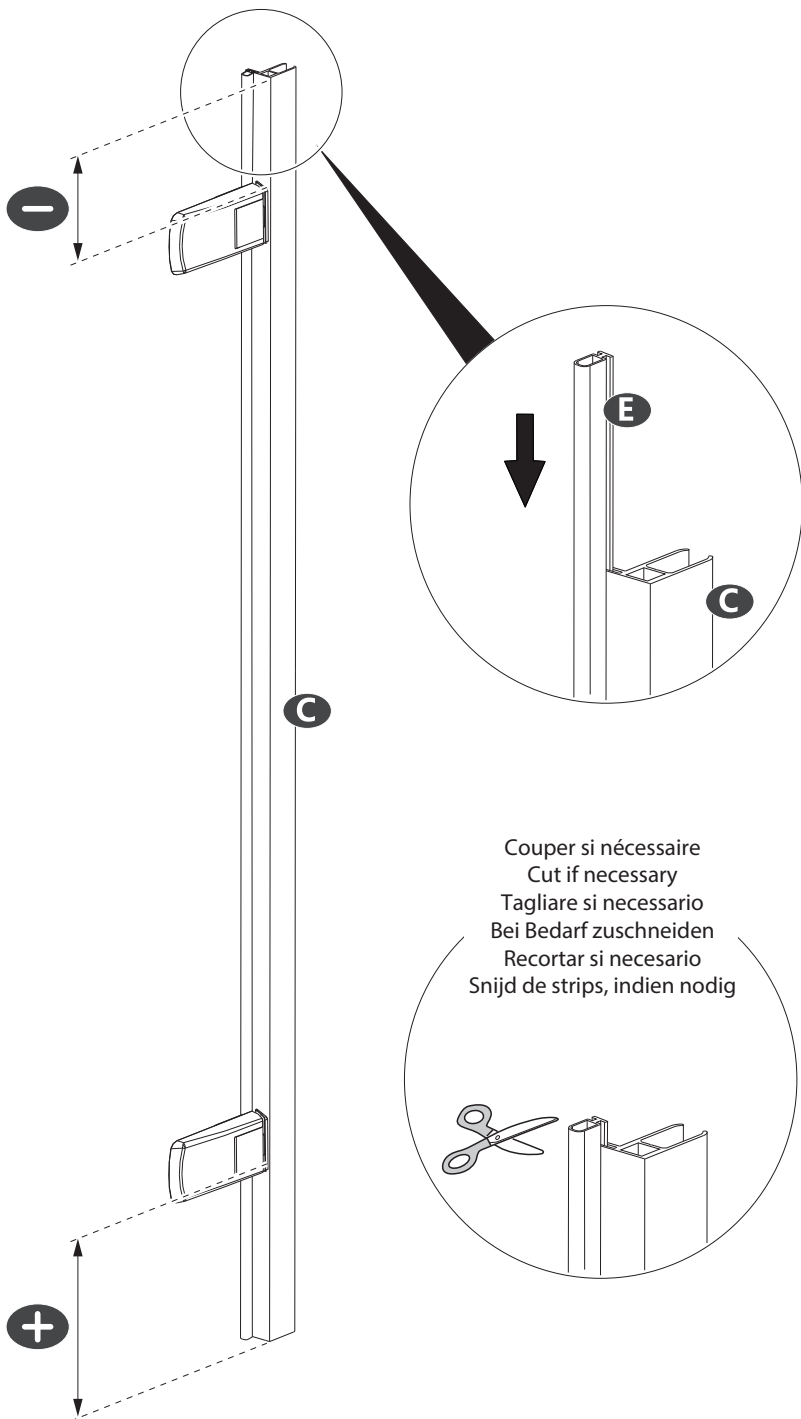

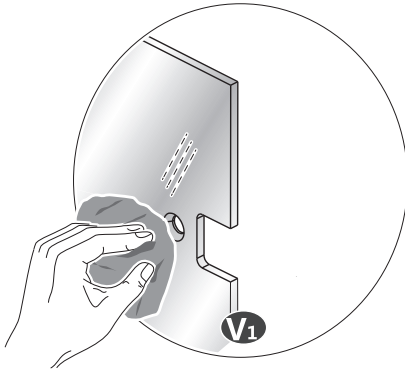

Utiliser uniquement de l'eau et sécher soigneusement
Only use water and dry carefully
Usare solo acqua e asciugare accuratamente
Nur Wasser verwenden und sorgfältig trocknen
Sólo utilice agua y seque cuidadosamente
Gebruik alleen water en droog zorgvuldig af

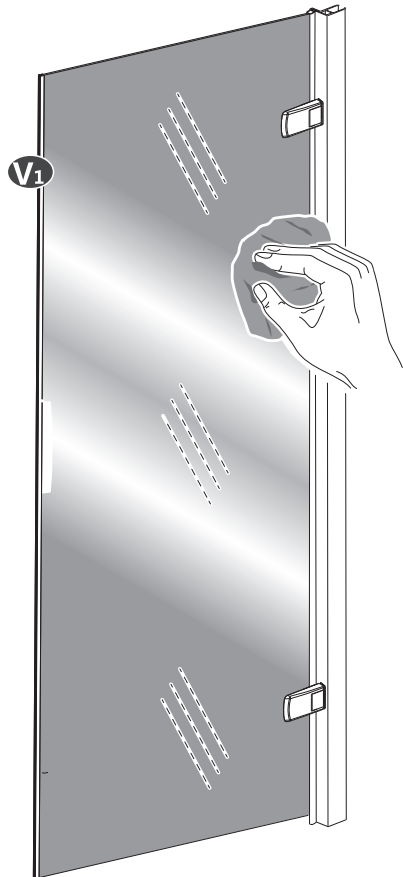

Interne
Internal
Interno
Innen
Interno
Intern

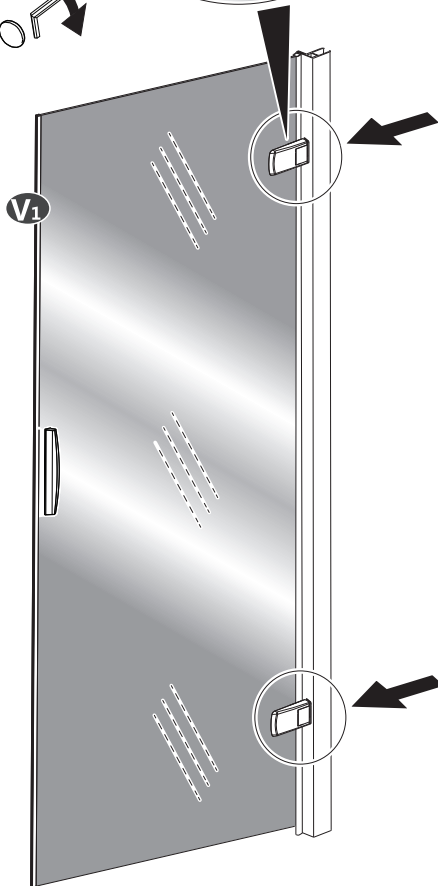
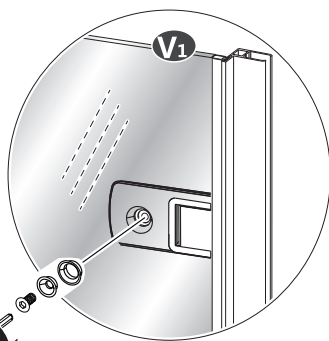
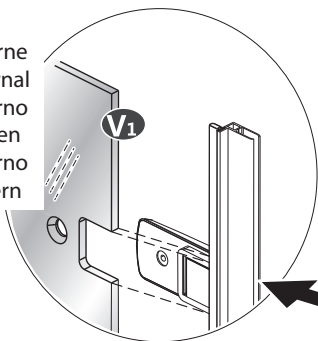

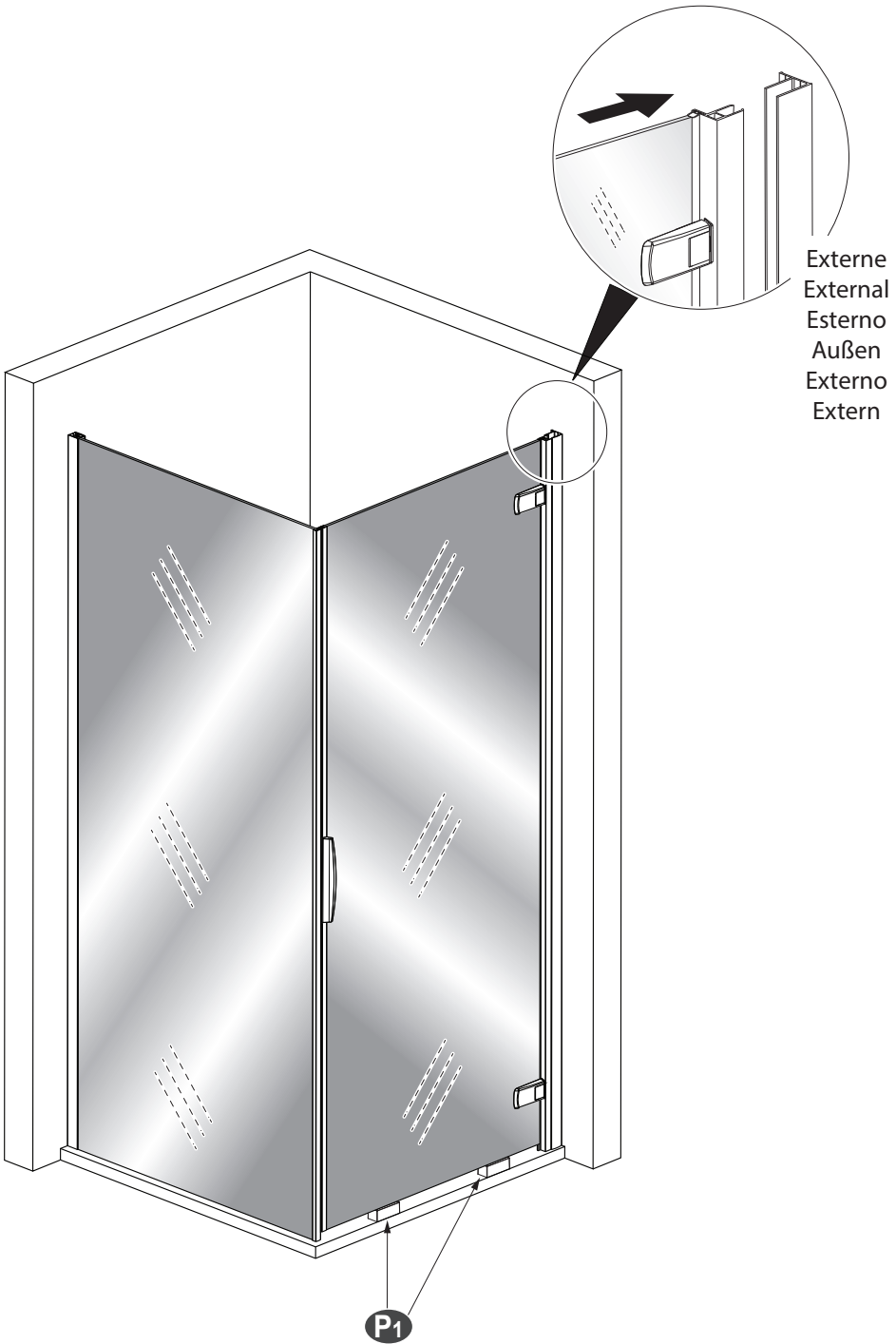

Utilisez uniquement les pièces nécessaires indiquées dans la figure
Use only the necessary parts shown in the figure
Utilizzare solo i particolari necessari indicati in figura
Verwenden Sie nur die in der Abbildung gezeigten Teile
Utilice únicamente las piezas necesarias que se muestran en la figura
Gebruik alleen de benodigde onderdelen die in de afbeelding worden getoond

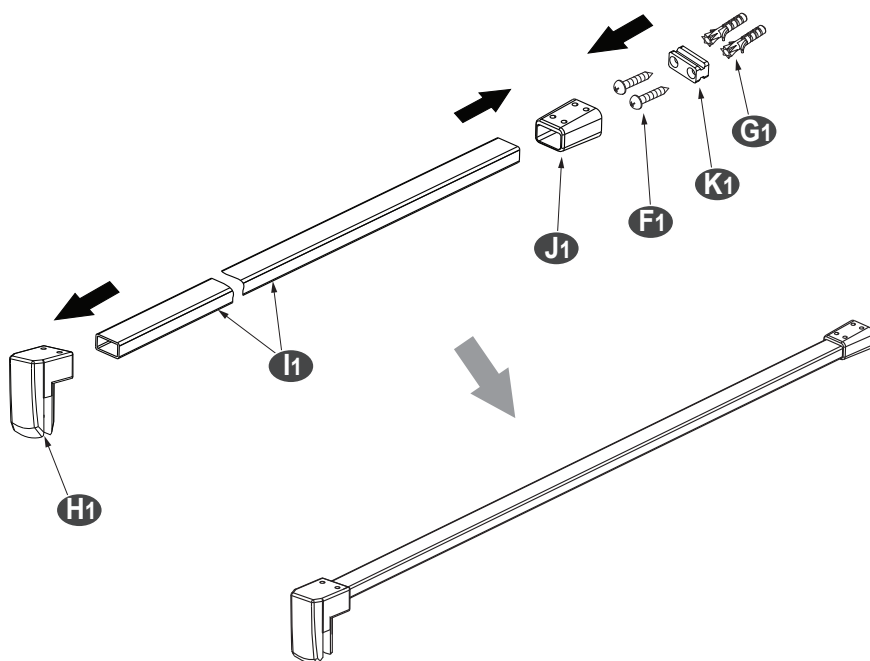

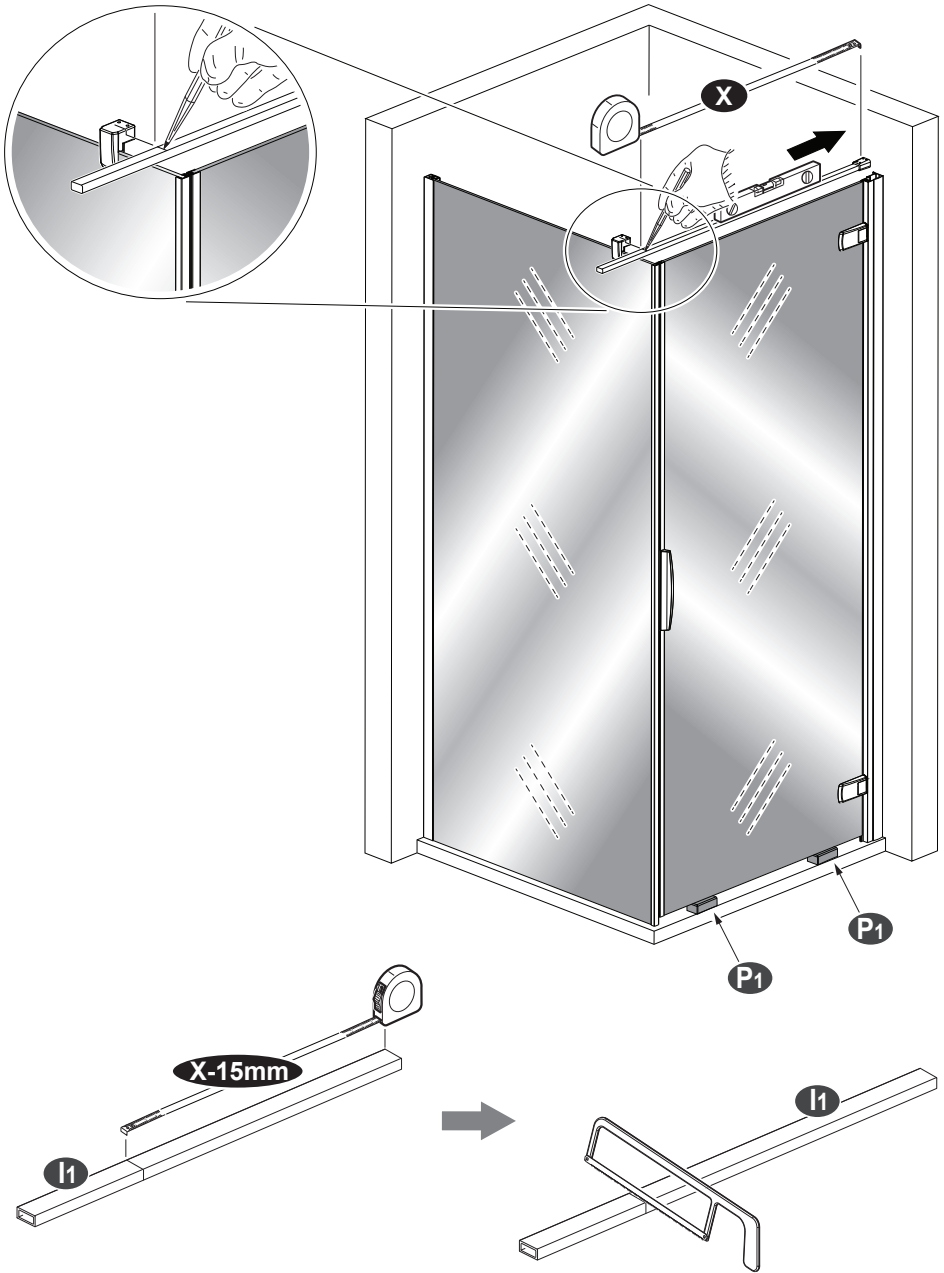

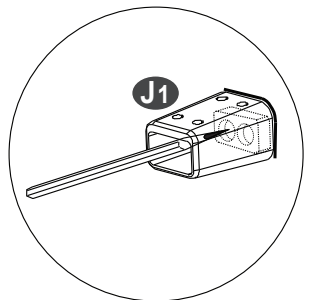
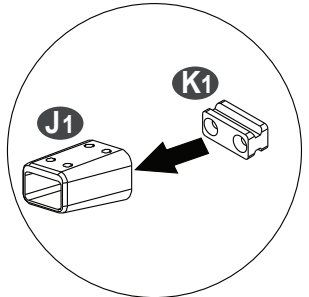
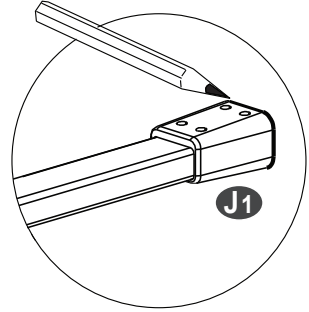
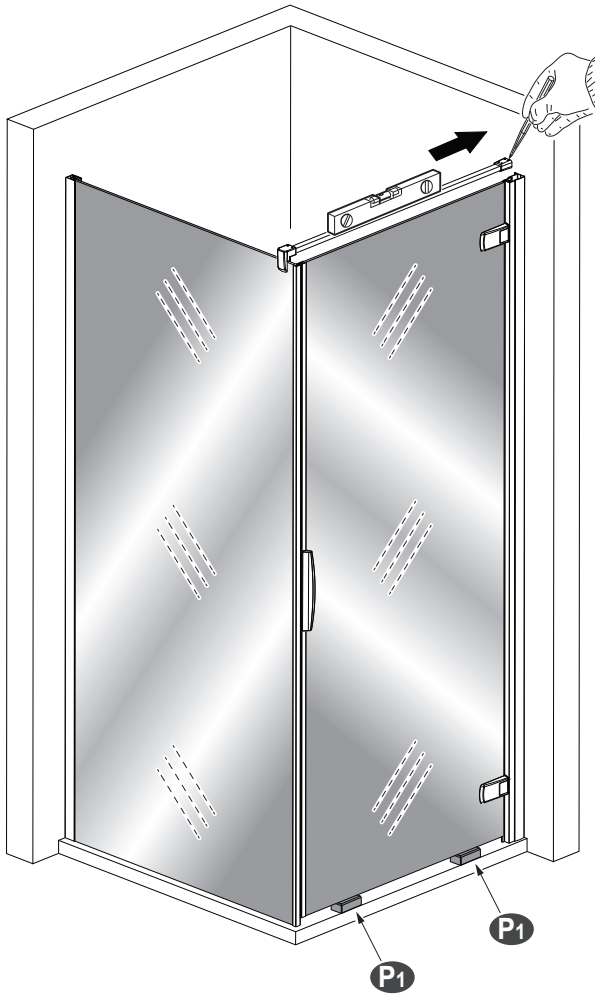

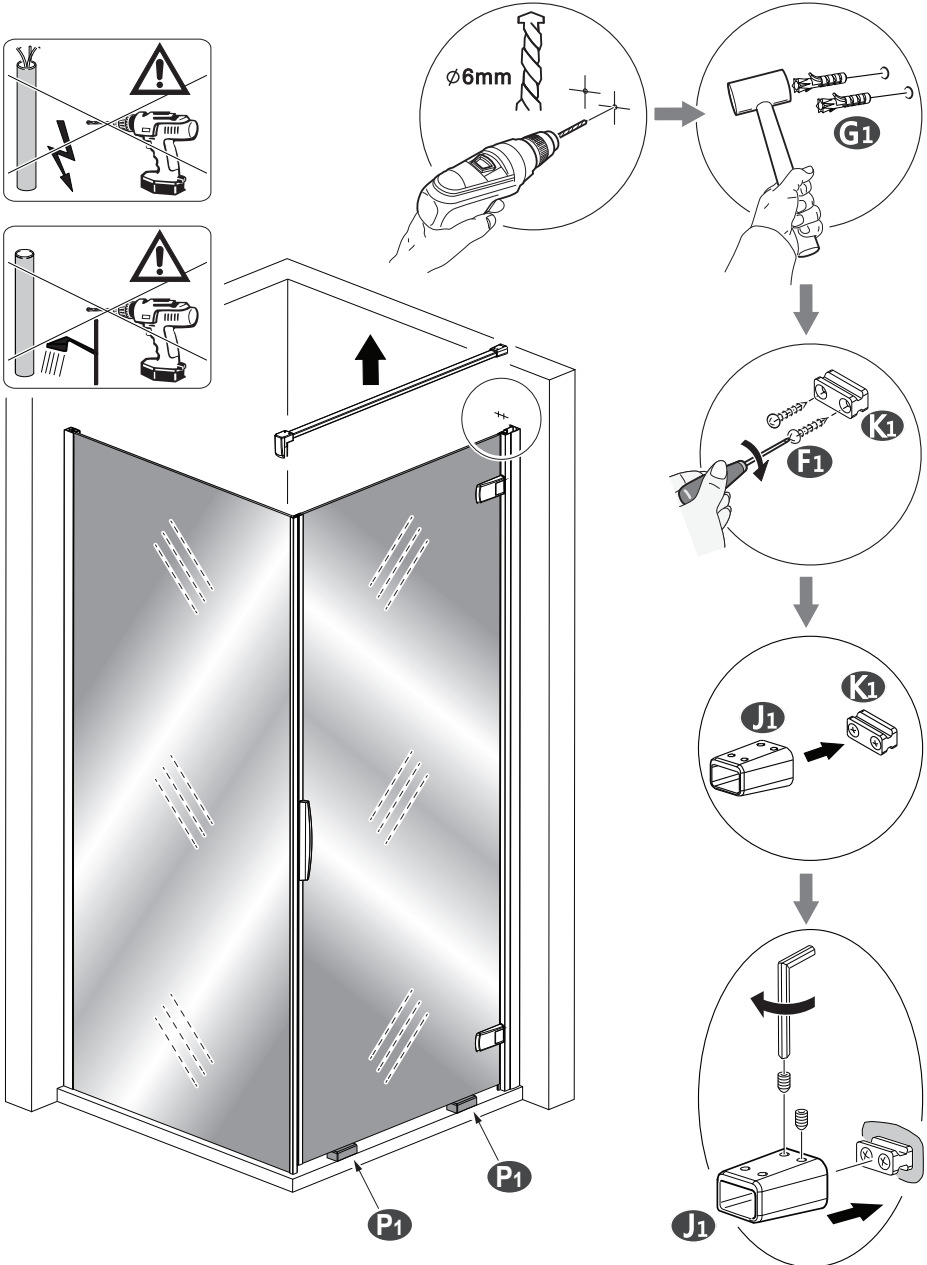

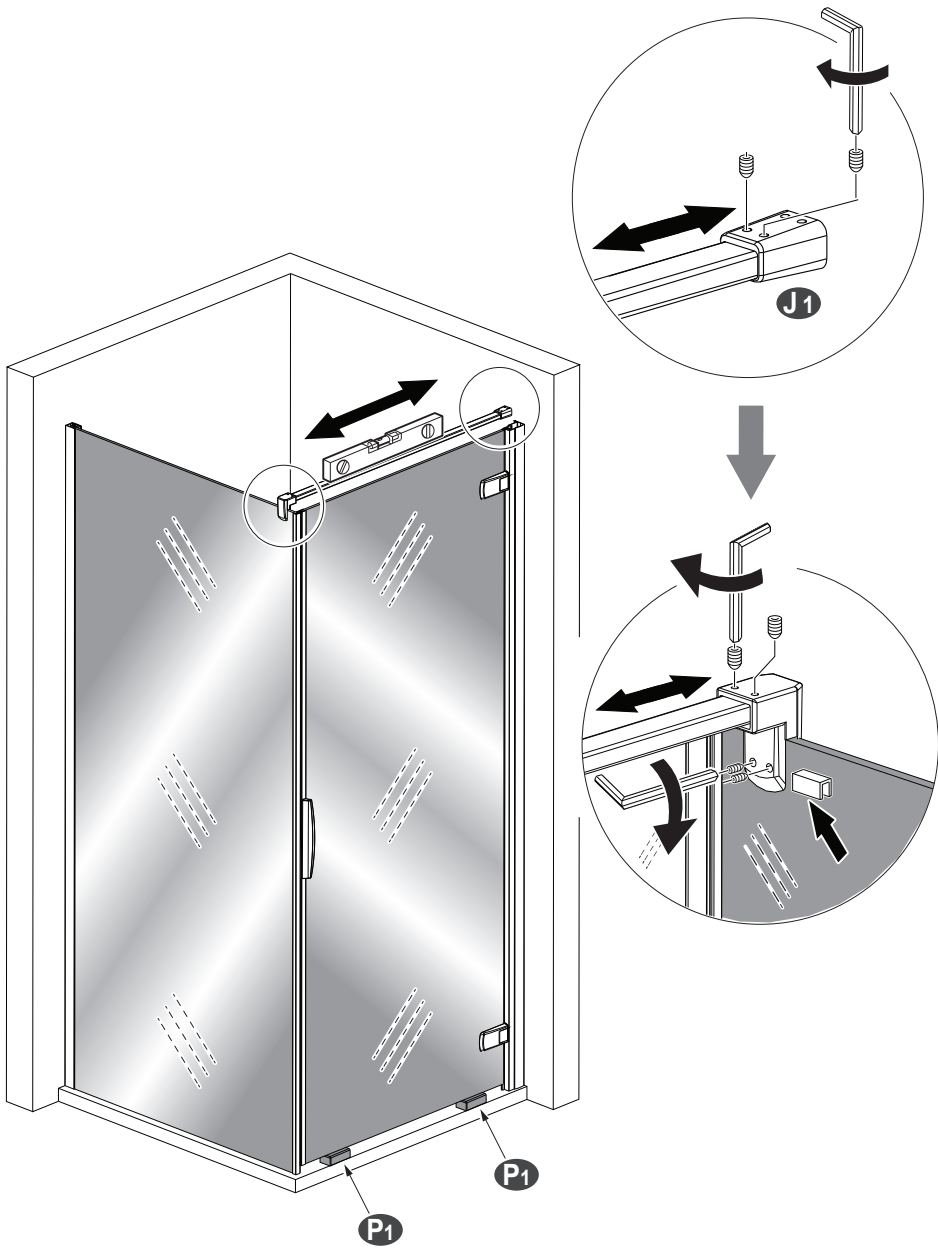

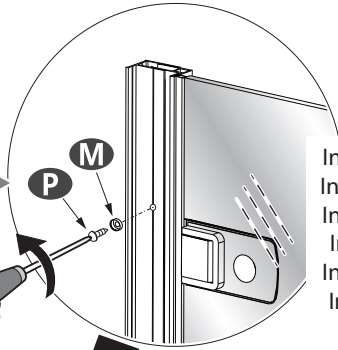
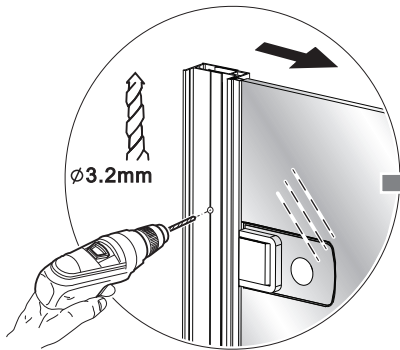

Interne
Internal
Interno
Innen
Interno
Intern

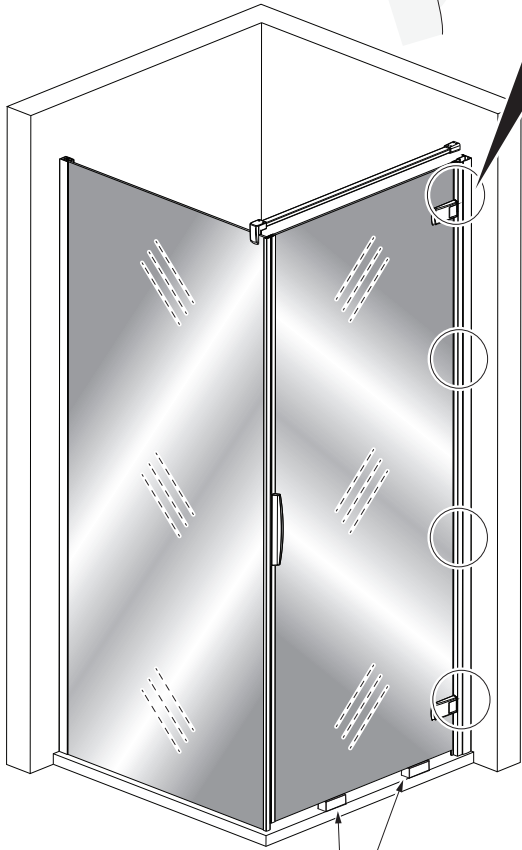

P1

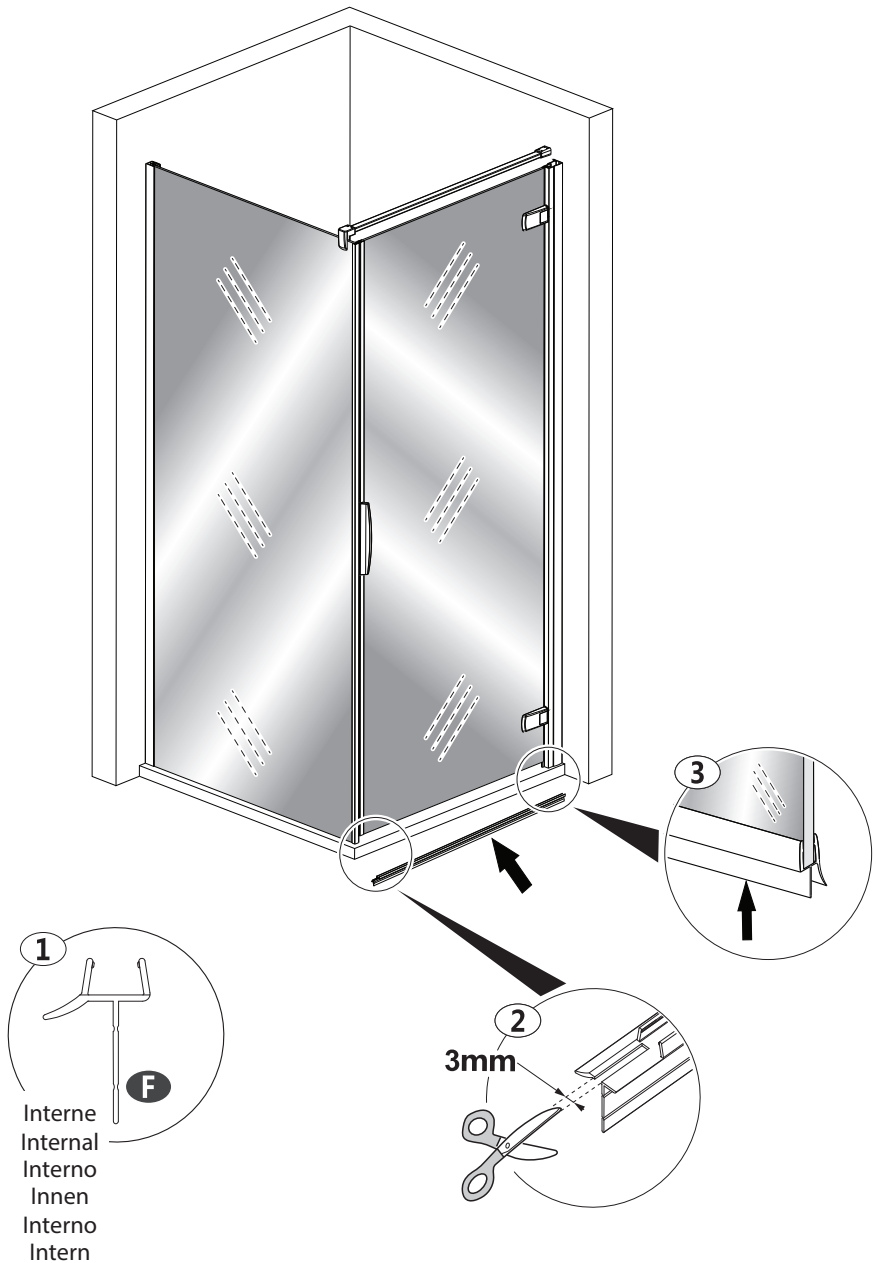

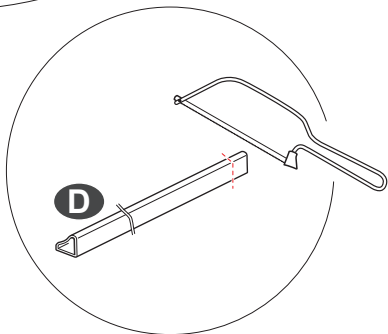
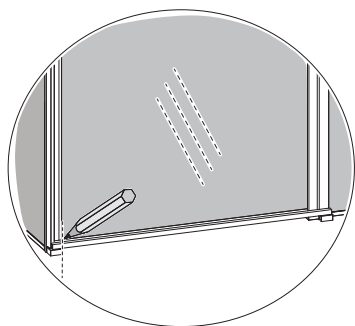

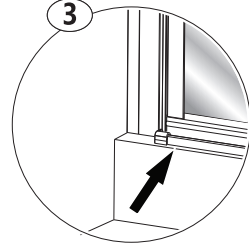
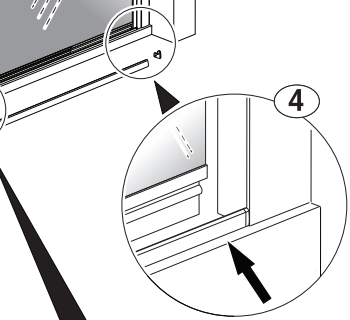
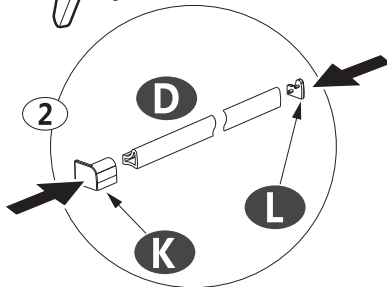
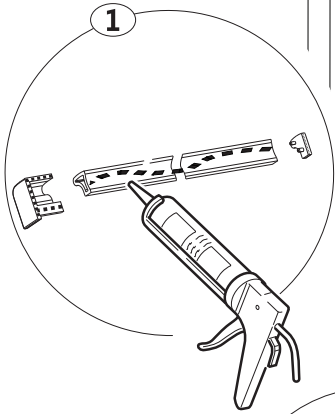
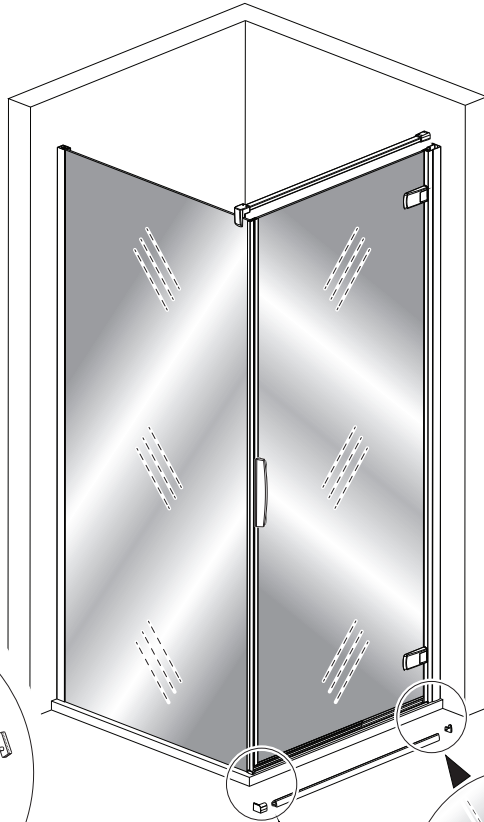

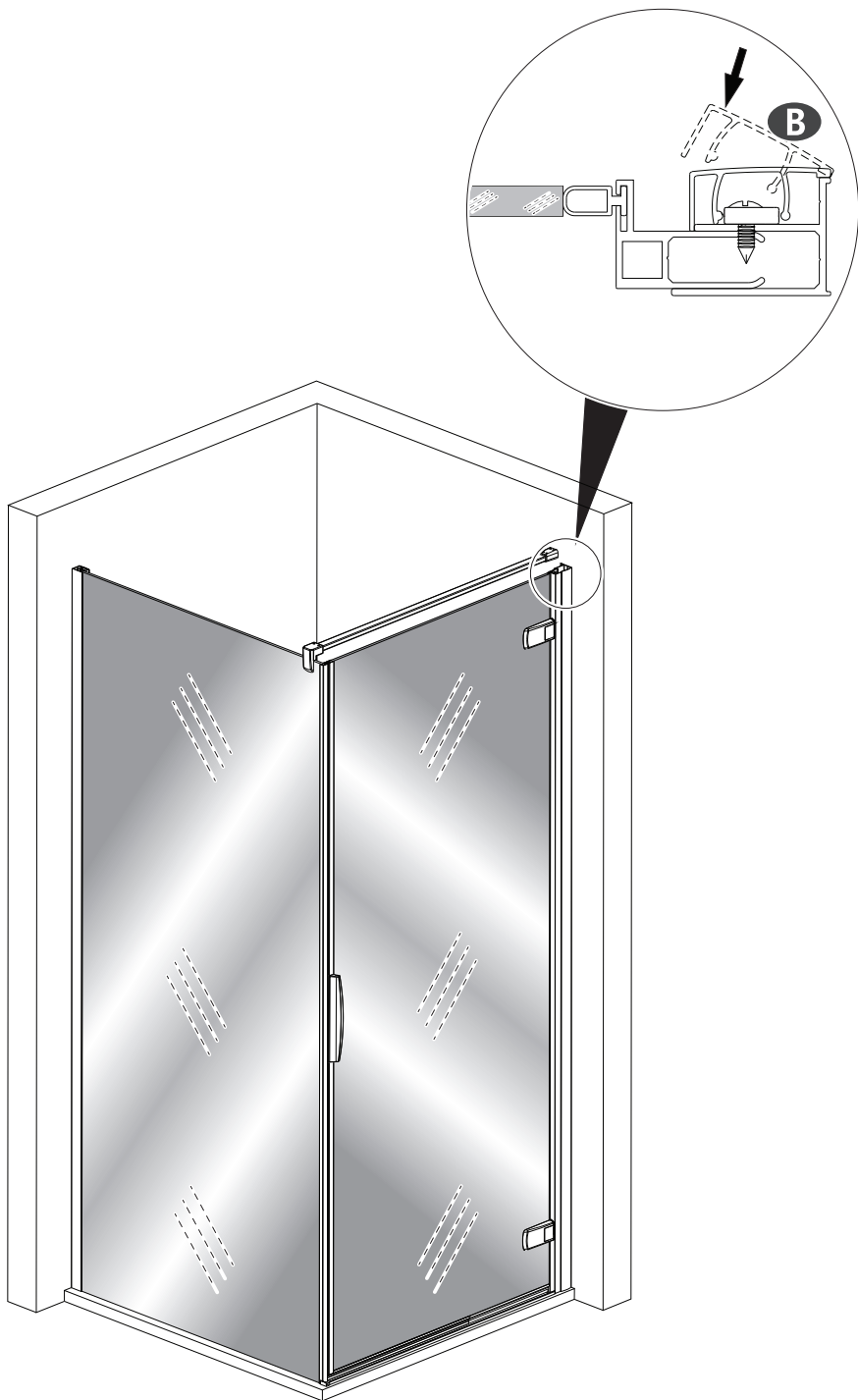

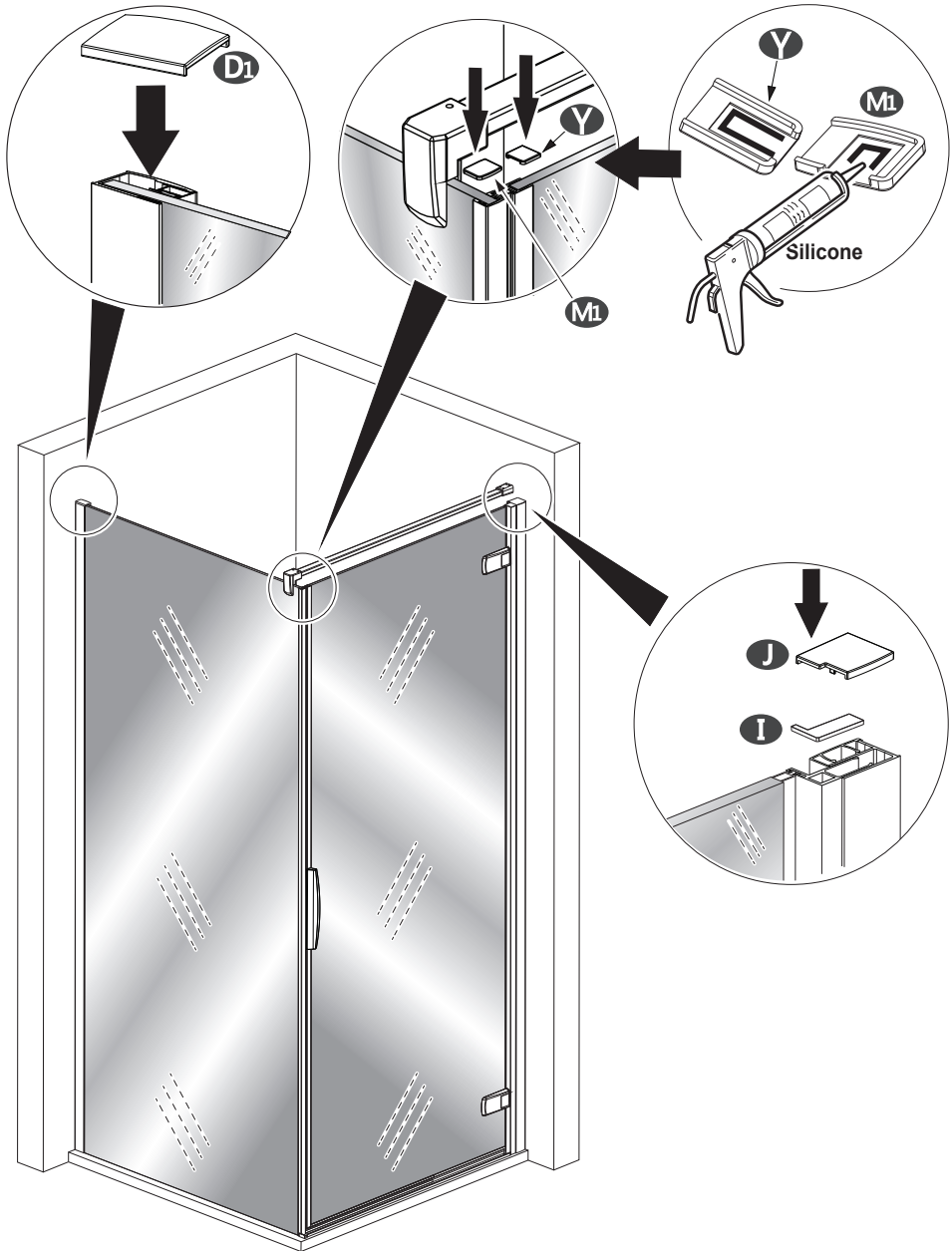

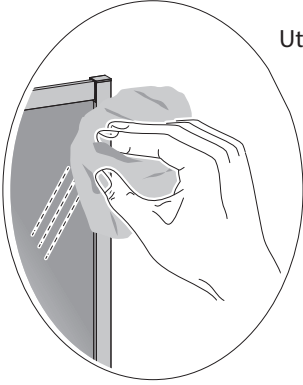

Utiliser uniquement de l'eau et sécher soigneusement

Only use water and dry carefully

Usare solo acqua e asciugare accuratamente

Nur Wasser verwenden und sorgfältig trocknen

Sólo utilice agua y seque cuidadosamente

Gebruik alleen water en droog zorgvuldig af

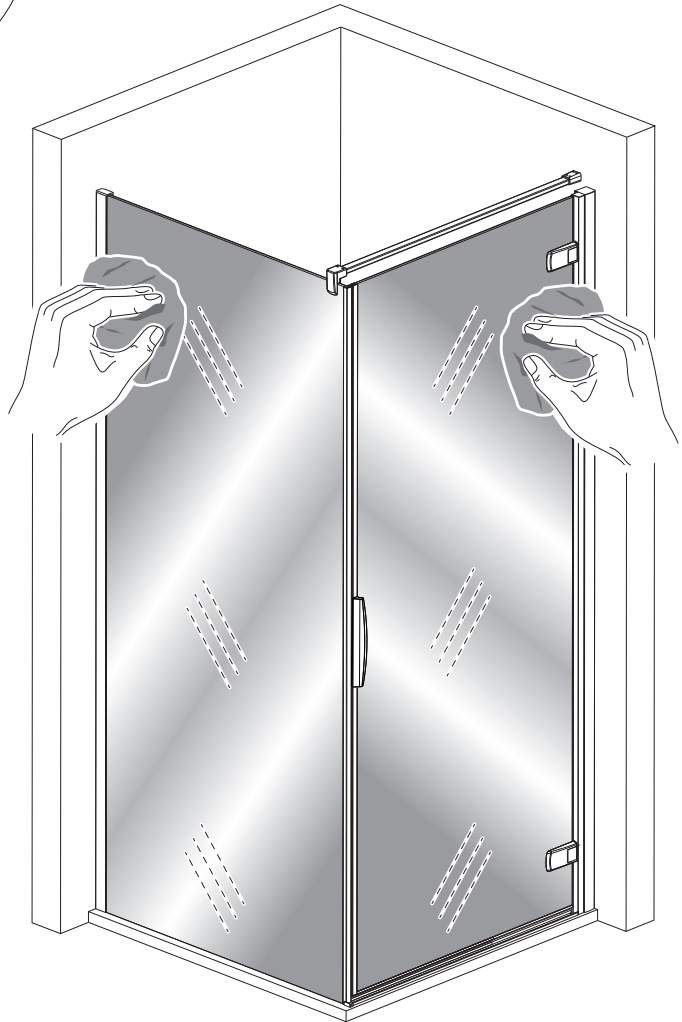

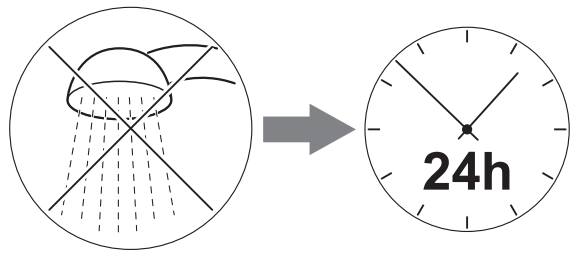
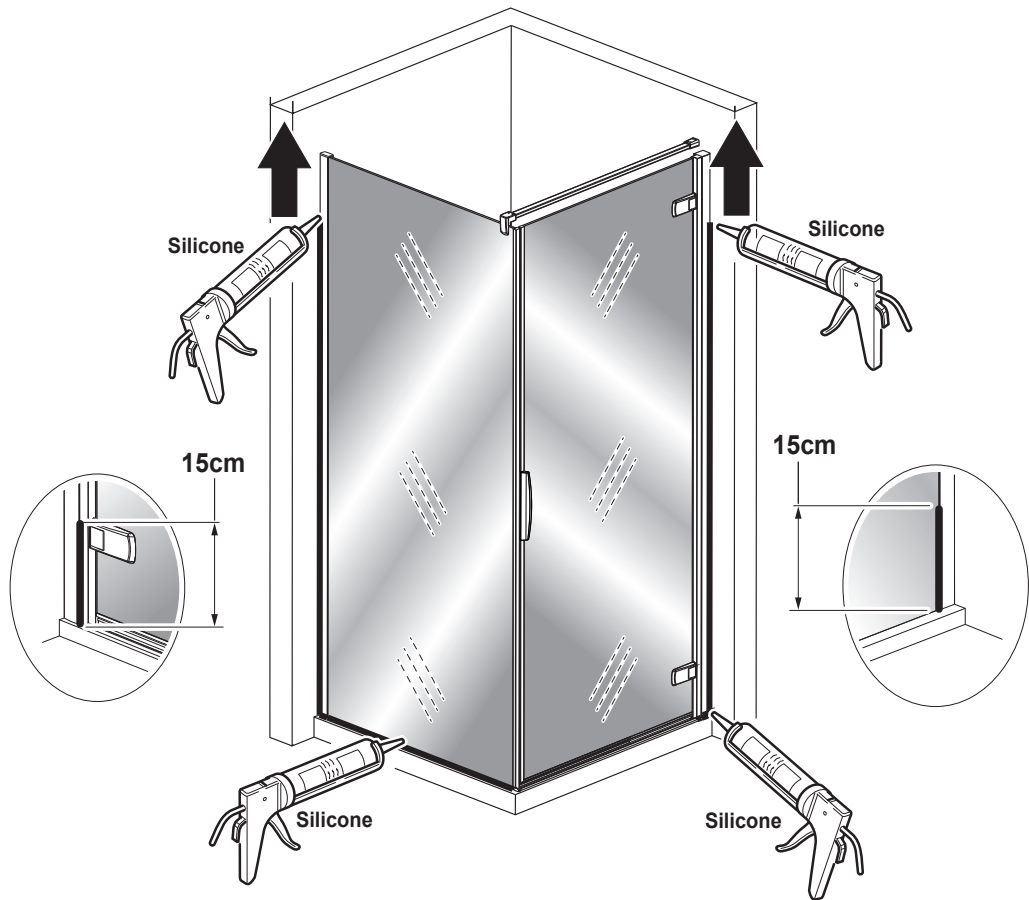



SAV
SERVICE HELPLINES
ASSISTENZA POST-VENTITA
SERVICIO POSTVENTA

FRANCE

02 40 21 29 45

UK

020 8842 0033

IRELAND

04697 33102

DEUTSCHLAND

+49 (0) 6074 / 30928 0

ITALIA

(0382) 6181

OSTEREICH

+43 1 710 60 70

SCHWEIZ

(01) 748 17 44

ESPANA

93 544 60 76

NEDERLAND

+31 475 487 100

BELGIE

+31 475 487 100

BELGIQUE

+31 475 487 100

РОССИЯ

963 19 40, 773 67 22



AQUAPRODUCTION, Site industriel,
 F - 44680 Chaumes-en-Retz

19

EN 14428

Paroi de douche, fabriquée en verre de silicate
 sodo-calcique de sécurité trempé thermiquement

Aptitude au nettoyage : réussite

Résistance à l'impact/propriétés de fragmentation : réussite

Durabilité : réussite