

- F Notice de montage
- E Manual de instalación
- NL Montage-instructies
- D Montageanleitung

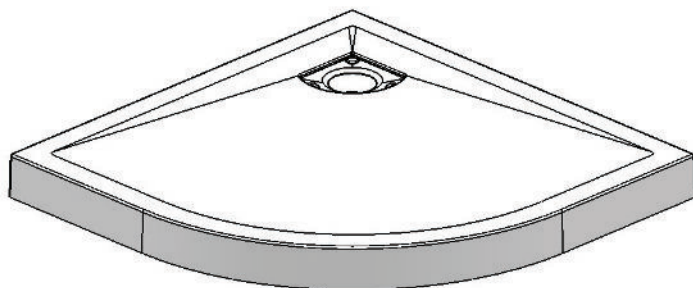

Notre service technique est
à votre écoute aux numéros
qui sont au dos de cette
notice d'installation

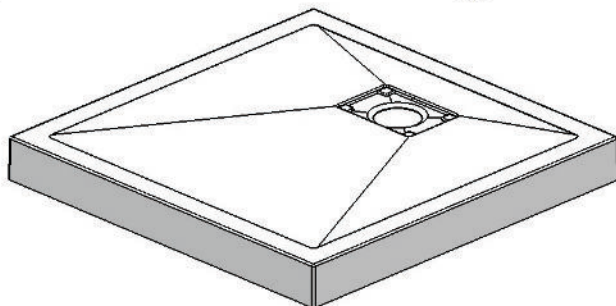
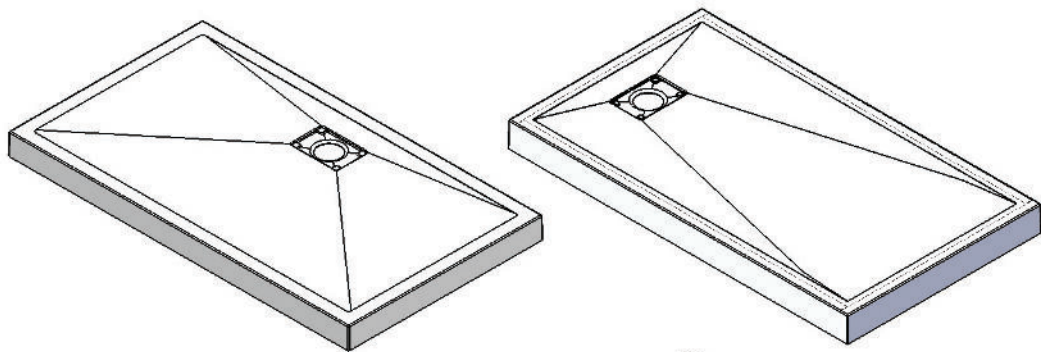

- F Attention aux étapes : Pages: 4 - 5
- E Atención a los pasos : Páginas: 6 - 7
- NL Aandacht voor de stappen : Pagina's: 8 - 9
- D Achtung vor den Schritten : Seiten: 10 - 11

(A)

X1

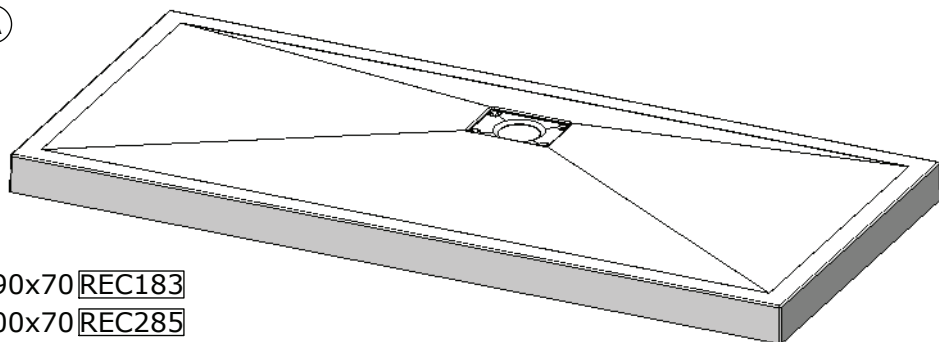

90x70	REC183				
100x70	REC285				
100x80	REC184	120x90	REC240	150x90	REC396
100x90	REC295	140x70	REC287	160x70	REC288
120x70	REC286	140x80	REC186	160x80	REC242
120x80	REC185	140x90	REC241	160x90	REC400
				170x70	REC243
				170x80	REC244
				170x90	REC296
				180x80	REC245

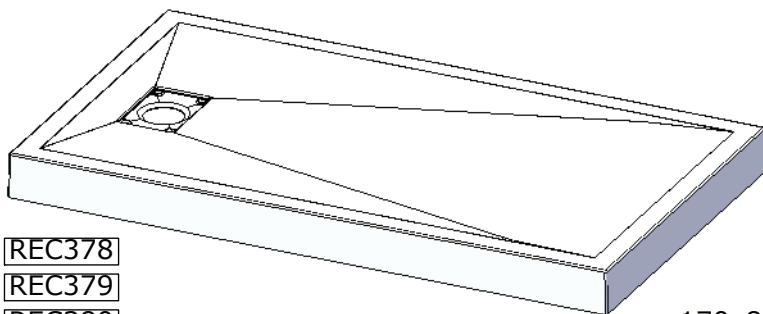

120x70	REC378				
120x80	REC379				
120x90	REC380				170x80
120x100	REC578	140x100	REC532	160x80	REC385
140x70	REC381	150x90	REC395	160x90	REC399
140x80	REC382	150x100	REC534	160x100	REC536
140x90	REC383	160x70	REC384	170x70	REC386
				170x90	REC388
				180x80	REC389
				180x90	REC538
				180x100	REC579

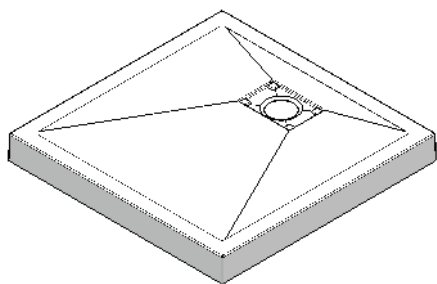

80x80	REC180
90x90	REC181
100x100	REC182

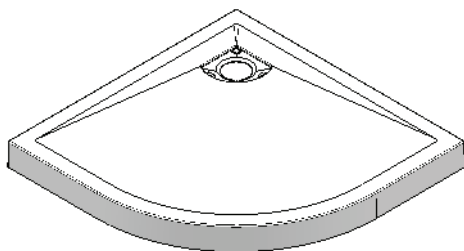

90x90	REC178
100x100	REC179

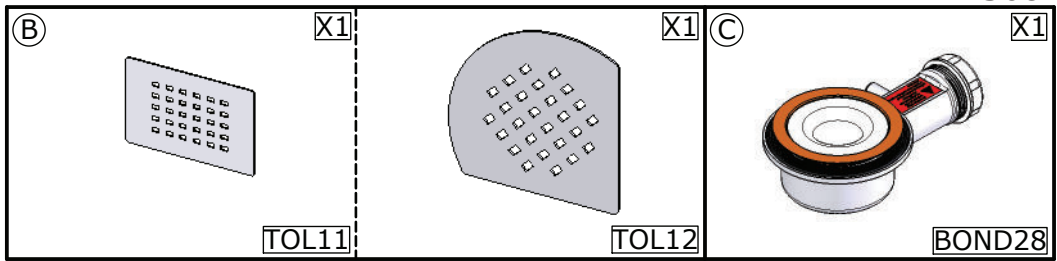

Les quantités données sont les quantités utiles au montage, les sachets fournis contiennent des pièces supplémentaires.
 Las cantidades indicadas son las cantidades necesarias para el montaje. Las bolsitas incluidas contienen piezas suplementarias.
 De aangegeven aantallen zijn vereist voor de montage. De verpakking bevat extra onderdelen.
 Die Mengenangaben beziehen sich auf die für die Montage nötigen Teile. Eventuell weitere beige-packte Teile ignorieren.

Matériel nécessaire / Material necesario Nodige gereedschap / Benötigtes Werkzeug

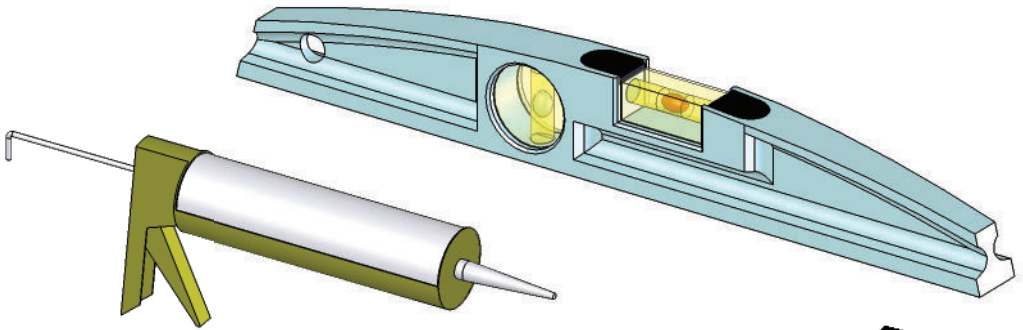

Utiliser un silicone adapté au matériau de chaque support (faïence, acrylique, etc.)

Usar una silicona adecuada para cada tipo de material (loza, acrílico, etc.)

Gebruik siliconenkit die geschikt is voor iedere ondergrond (tegelwerk, acryl, etc.)

Für das jeweilige Trägermaterial (Stein, Acryl usw.) geeignetes Silikon verwenden

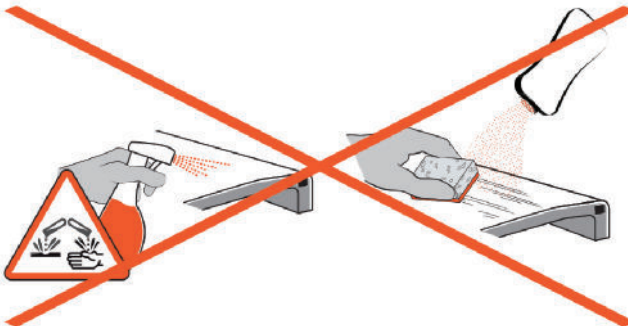

F

Tracer la position de la bonde et réaliser un montage à blanc de la bonde et du receveur

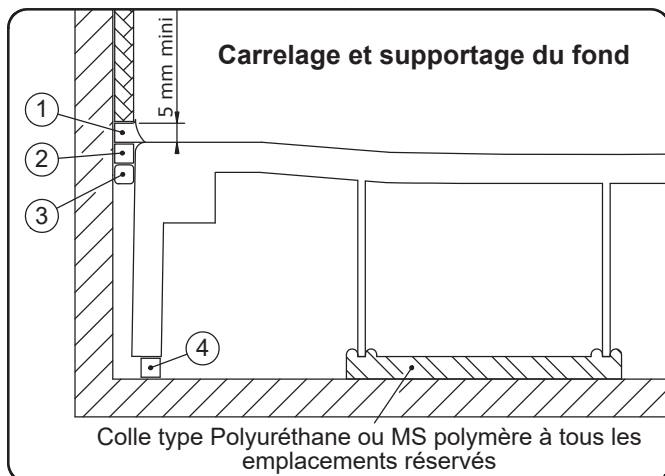
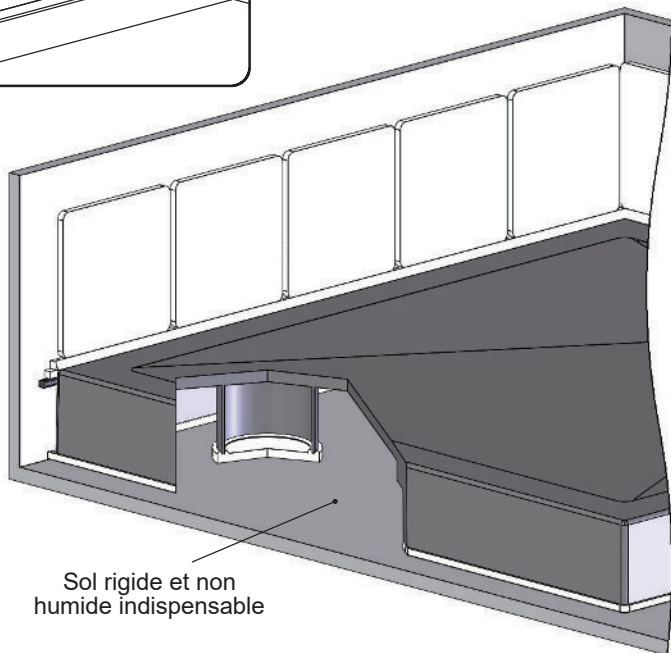
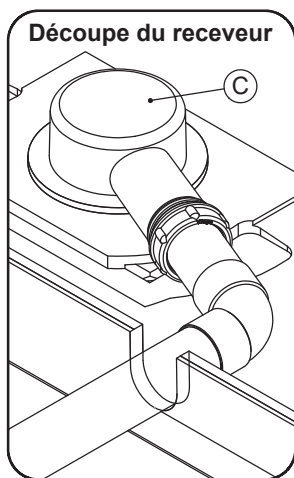
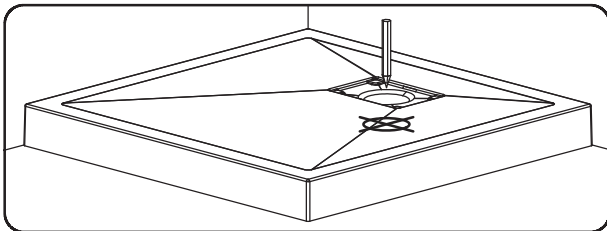



Le montage d'une *soupape anti-vide* est nécessaire pour une utilisation optimale si un autre appareil sanitaire est raccordé sur la même évacuation.

- ① - silicone de finition traité antifongique de 5mm de largeur minimum
- ② - silicone d'étanchéité souple traité antifongique
- ③ - élément de soutien du joint silicone
- ④ - silicone d'appui

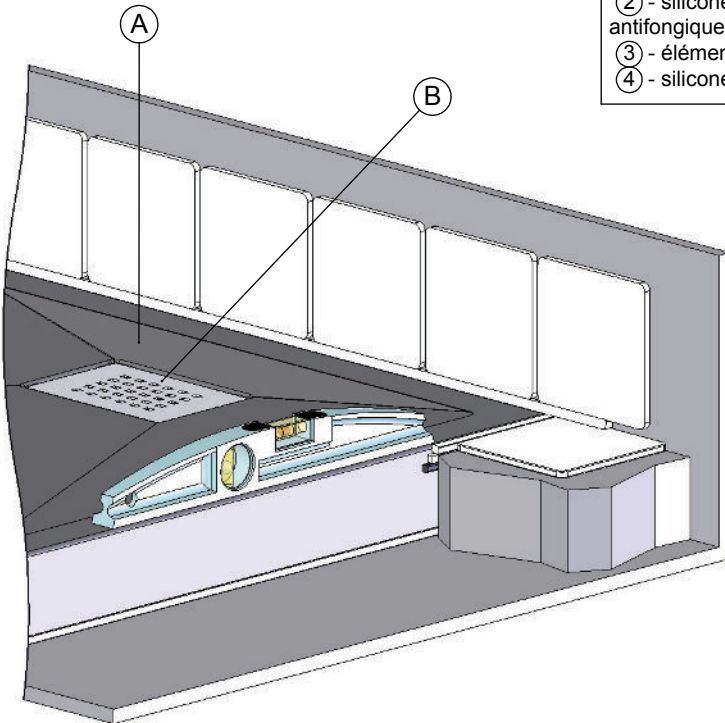

Pendant toute la durée des travaux, protéger le receveur contre toute agression : brûlures, chocs, rayures, décapants...



Le receveur ne doit subir aucune modification (sciage, meulage de renfort...) autre que celles prévues par le fabricant.

Pose directe au sol

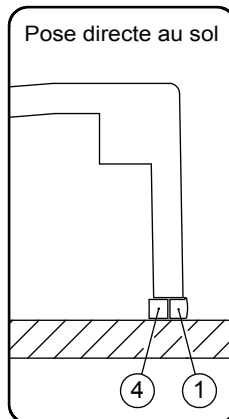

Encastrement bord à bord

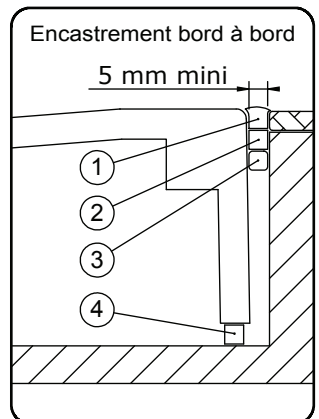

E

Marcar la posición del desagüe y realizar una prueba de montaje con el plato.

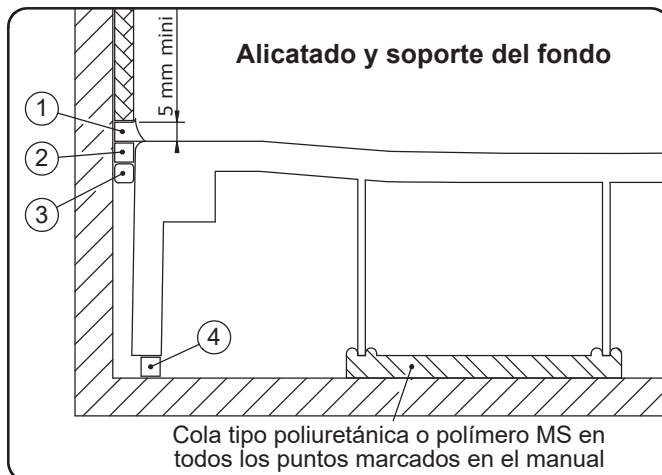
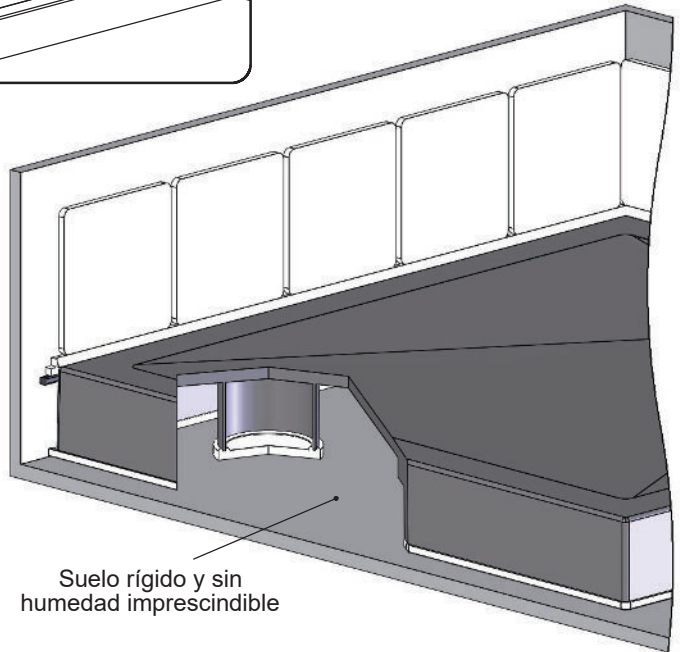
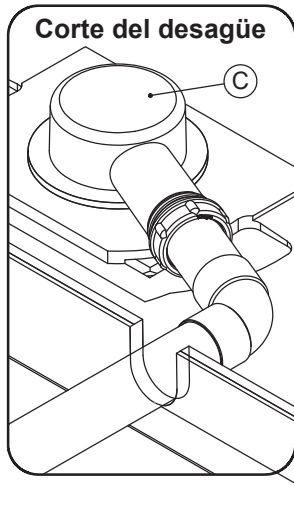
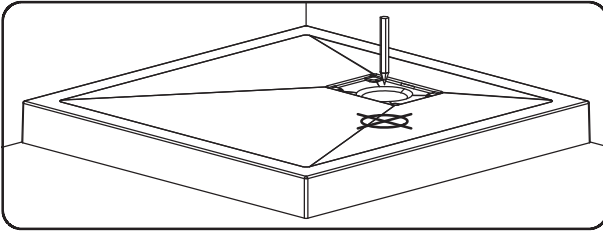



La instalación de una válvula anti-retorno es imprescindible para un uso óptimo, en caso de conectar otro aparato sanitario al mismo tubo de evacuación.

- ① - silicona antimoho, 5 mm mínimo de ancho
- ② - silicona blanda antimoho de estanqueidad
- ③ - soporte (goma...) de la junta silicona
- ④ - base de silicona

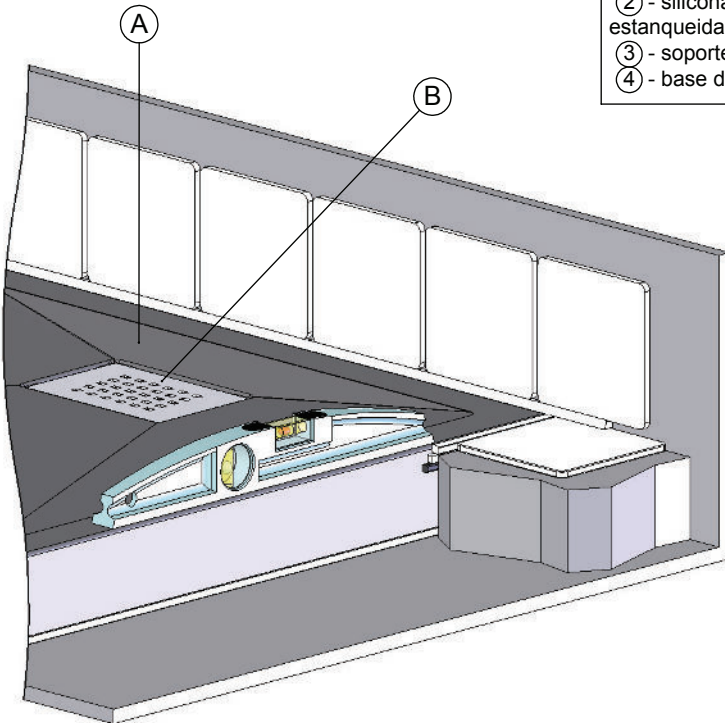

Durante todas las obras, proteger el plato contra cualquier tipo de daño : quemaduras, golpes, rayas, productos agresivos...



El plato no debe sufrir ninguna alteración (cortes, amoladuras...) que las previstas por el fabricante

Instalación al suelo

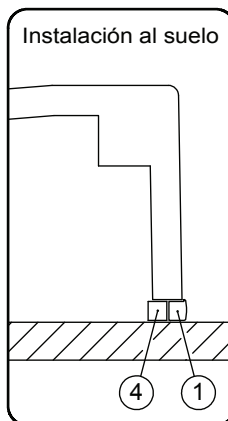

Empotrar borde a borde

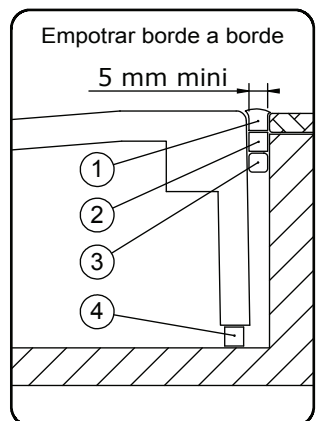

 NL

Markeer de positie van de stekker en het uitvoeren van een vergadering van de plug leeg en de ontvanger.

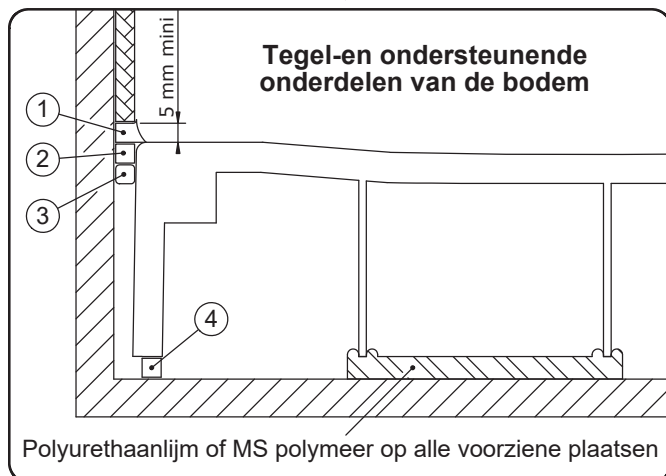
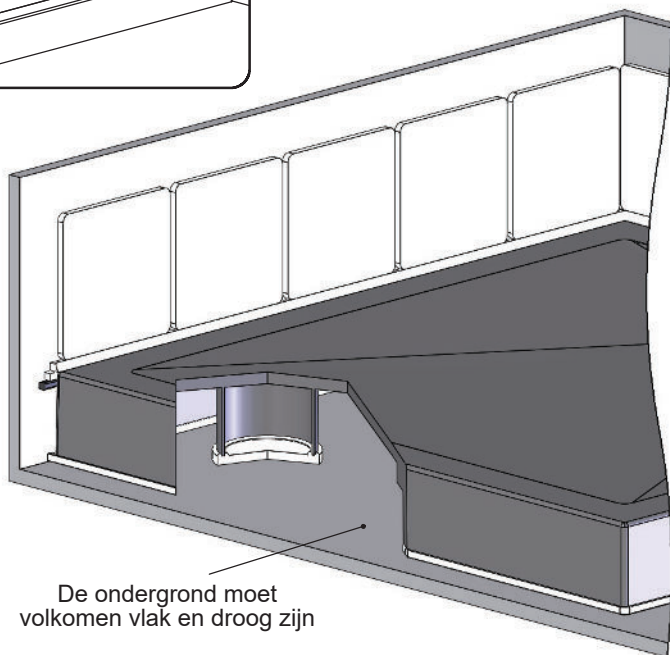
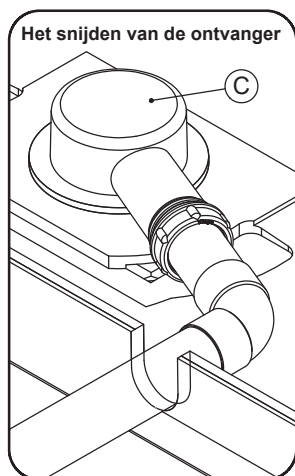
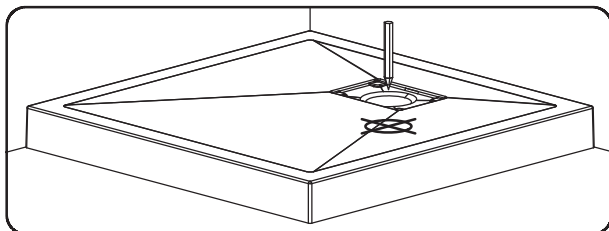



Monteren terugslagklep vacuum vereist voor een optimaal gebruik als een andere inrichting is aangesloten op hetzelfde ontladen.

- ① - schimmelwerende siliconenkit met een lengte van minimaal 5mm
- ② - siliconenkit voor een waterdichte afwerking, met schimmelwerende werking
- ③ - support element siliconenaafdichting
- ④ - siliconen ondersteuning

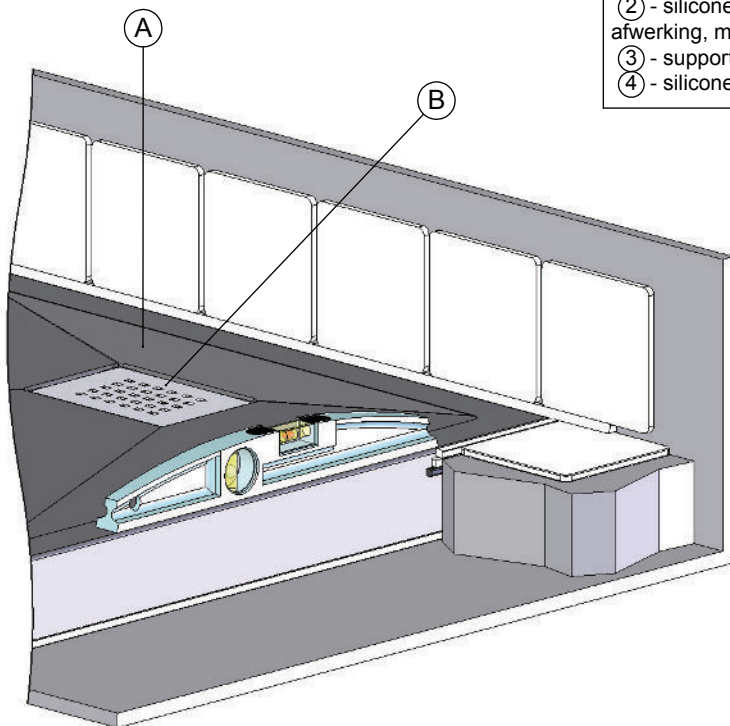

In het werk, te beschermen van de ontvanger tegen iedere agressie : brandwonden, shock, krassen, afbijtmiddelen, ...



De ontvanger zal niet lijden enige wijziging (zagen, slijpen versterking...), andere dan van de fabrikant.

Direct op de grond

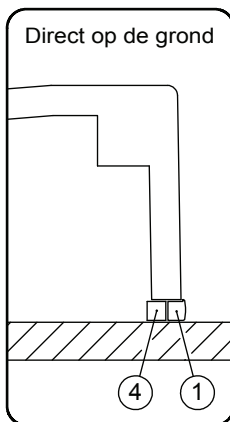

Spoel rand tot rand

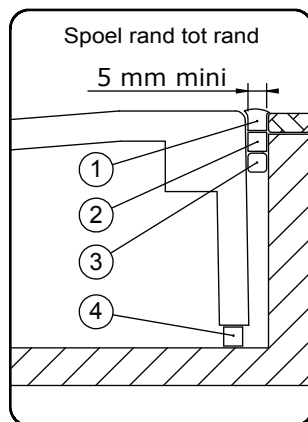

D

Die Position für den Ablauf anzeichnen und vormontieren

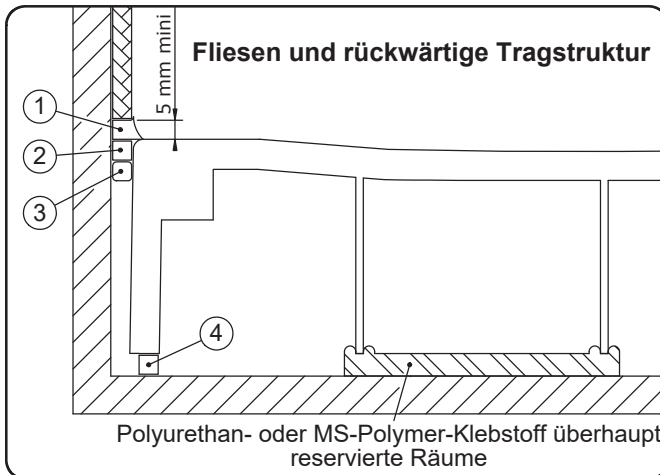
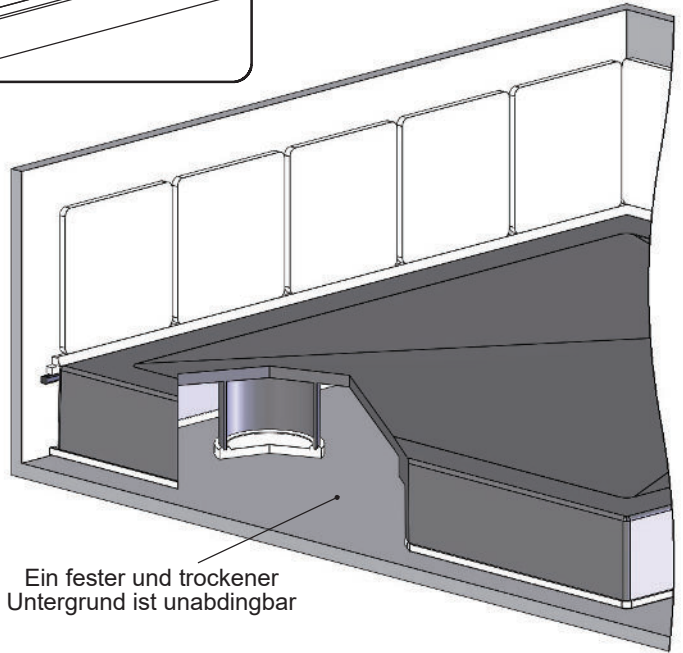
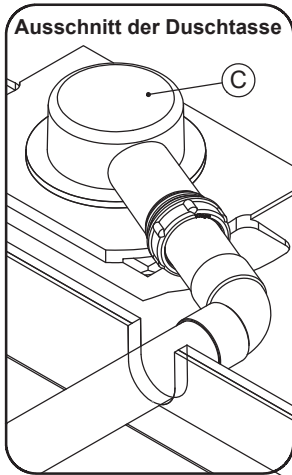
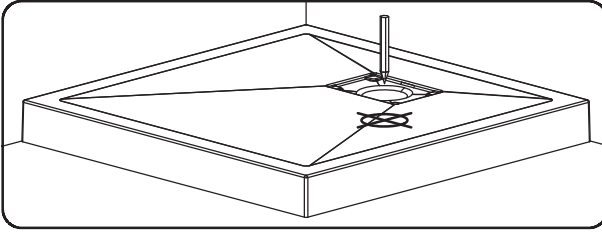

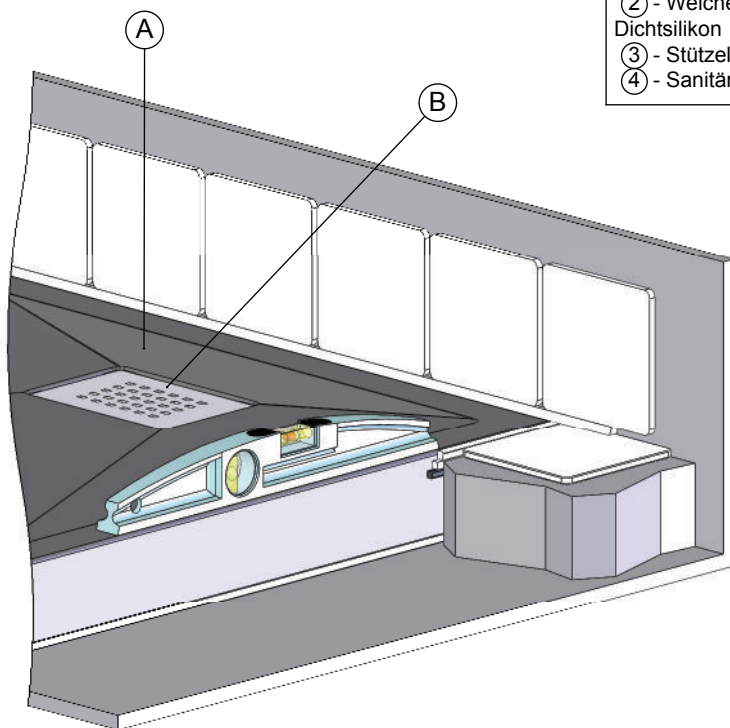

- ① - Pilzhemmendes Silikon mit einer Mindestbreite von 5mm
 ② - Weiches pilzhemmendes Dichtsilikon
 ③ - Stützelement der Silikondichtung
 ④ - Sanitärsilikon



Während der gesamten Dauer der Arbeiten ist die Duschtasse vor allen möglichen Beschädigungen zu schützen



Die Duschtasse darf in keiner anderen als vom Hersteller vorgesehenen Art und Weise verändert werden (durch Sägen, Schleifen etc.)

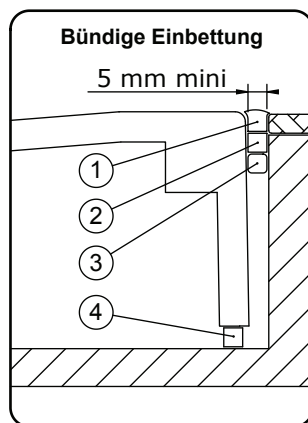
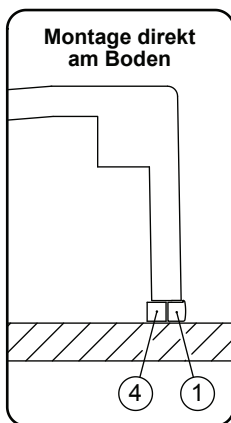



SAV
SERVICE HELPLINES
ASSISTENZA POST-VENTITA
SERVICIO POSTVENTA

FRANCE

02 40 21 29 45

UK

020 8842 0033

IRELAND

04697 33102

DEUTSCHLAND

+49 (0) 6074 / 30928 0

ITALIA

(0382) 6181

OSTEREICH

+43 1 710 60 70

SCHWEIZ

(01) 748 17 44

ESPANA

93 544 60 76

NEDERLAND

+31 475 487 100

BELGIE

+31 475 487 100

BELGIQUE

+31 475 487 100

РОССИЯ

963 19 40, 773 67 22



AQUAPRODUCTION, Site industriel,
 F - 44680 Chaumes-en-Retz

09

EN 14527 - CL2

Aptitude au nettoyage : satisfaisant
 Durabilité : satisfaisant