

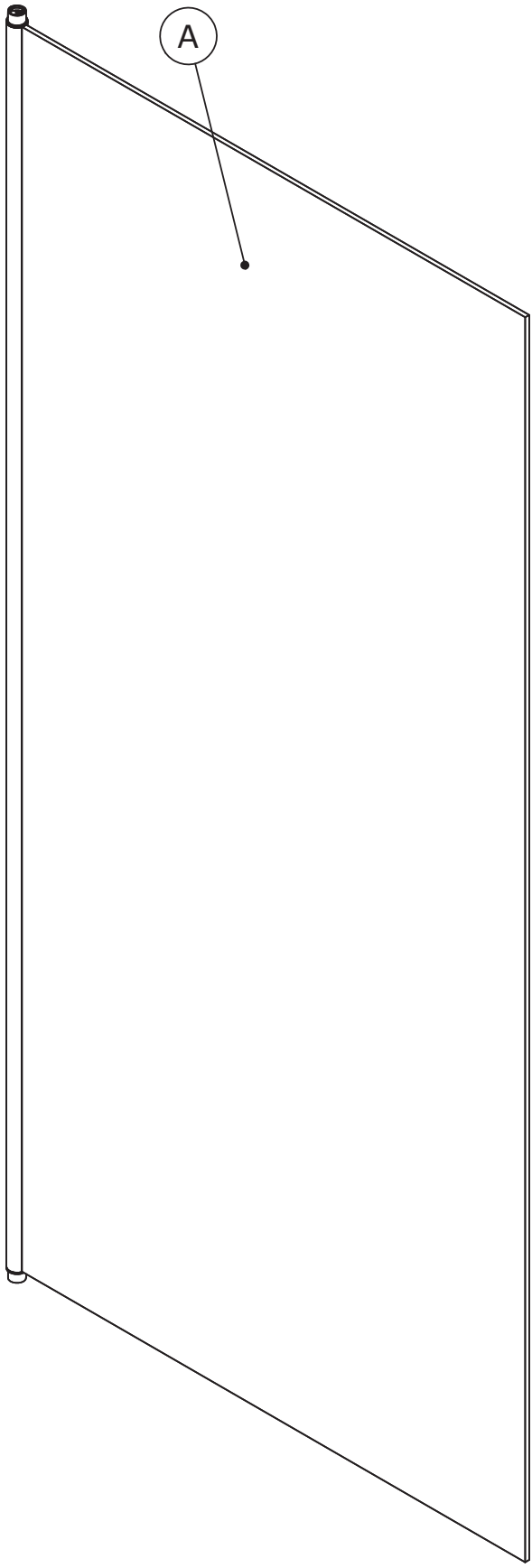

# NOTICE DE MONTAGE INSTALLATION INSTRUCTIONS MANUAL DE INSTALACIÓN MANUAL DE INSTALAÇÃO ISTRUZIONI DI MONTAGGIO INSTALLATIE VOORSCHRIFTEN INSTALLATIONSANLEITUNG



Attention aux étapes :  
Check installation steps :  
Atención a los pasos:  
Atenção aos passos: P:6 - 10 - 14  
Attenzione ai passi :  
Aandacht voor de stappen :  
Achtung vor den Schritten :

DES1539B

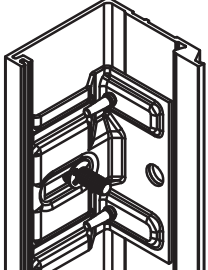
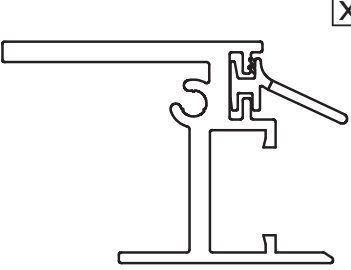
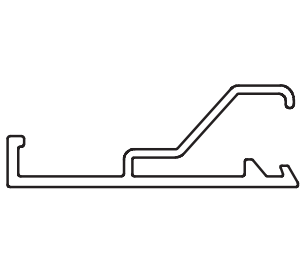
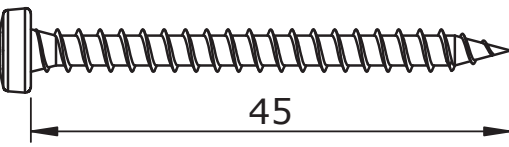
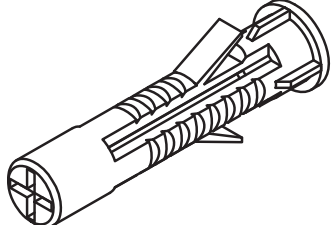
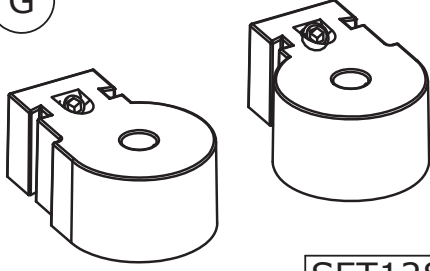

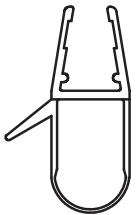
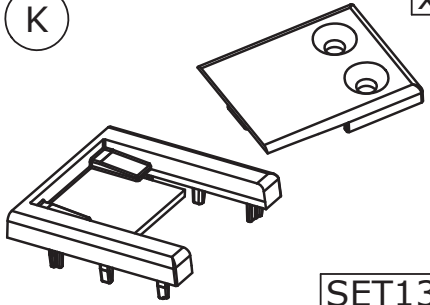
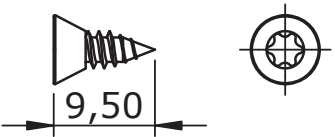
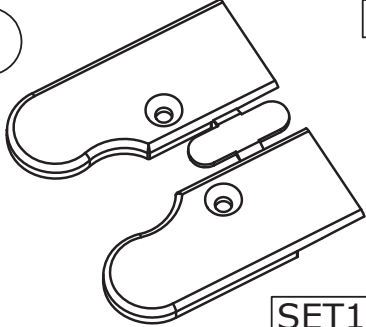
<p>(B)  x1</p> <p>LG=1500mm <span style="border: 1px solid black; padding: 2px;">6268</span></p>	<p>(C)  x1</p> <p>LG=1500mm <span style="border: 1px solid black; padding: 2px;">6272</span></p>	<p>(D)  x1</p> <p>LG=1500mm <span style="border: 1px solid black; padding: 2px;">6270</span></p>
<p>(E)  <span style="border: 1px solid black; padding: 2px;">Ø3,5mm</span> x4</p> <p><span style="border: 1px solid black; padding: 2px;">45</span></p> <p><span style="border: 1px solid black; padding: 2px;">VIS231</span></p>	<p>(F)  x4</p> <p><span style="border: 1px solid black; padding: 2px;">CHE02</span></p>	
<p>(G)  x1</p> <p><span style="border: 1px solid black; padding: 2px;">SET128</span></p>	<p>(H)  x1</p> <p><span style="border: 1px solid black; padding: 2px;">PPL1248</span></p>	<p>(I)  x1</p> <p><span style="border: 1px solid black; padding: 2px;">SET134</span></p>
<p>(J)  x1</p> <p>LG=1600mm <span style="border: 1px solid black; padding: 2px;">JOI279</span></p>	<p>(K)  x1</p> <p><span style="border: 1px solid black; padding: 2px;">SET137</span></p>	<p>(L)  <span style="border: 1px solid black; padding: 2px;">Ø3,5mm</span> x1</p> <p><span style="border: 1px solid black; padding: 2px;">9,50</span></p> <p><span style="border: 1px solid black; padding: 2px;">VIS261</span></p>
<p>(M)  x1</p> <p><span style="border: 1px solid black; padding: 2px;">SET174</span></p>	<p>Les quantités données sont les quantités utiles au montage. les sachets fournis contiennent des pièces supplémentaires.</p> <p>The quantities given are what are required for the installation. There may be some surplus in the package provide.</p> <p>Las cantidades indicadas son las cantidades necesarias para el montaje. Las bolsitas incluidas contienen piezas suplementarias.</p> <p>As quantidades indicadas são as quantidades necessárias para a montagem. Os sacos fechados contém peças adicionais.</p> <p>Le quantità fornite sono le quantità necessarie al montaggio. I sacchetti forniti contengono pezzi supplementari.</p> <p>De aangegeven aantallen zijn vereist voor de montage. De verpakking bevat extra onderdelen.</p> <p>Die Mengenangaben beziehen sich auf die für die Montage nötigen Teile. Eventuell weitere beige packte Teile ignorieren.</p>	

Matériel nécessaire - Tools required  
 Equipamiento necesario - Equipamento necessário  
 Materiale necessario - Benodigd gereedschap - Benötigte Werkzeuge

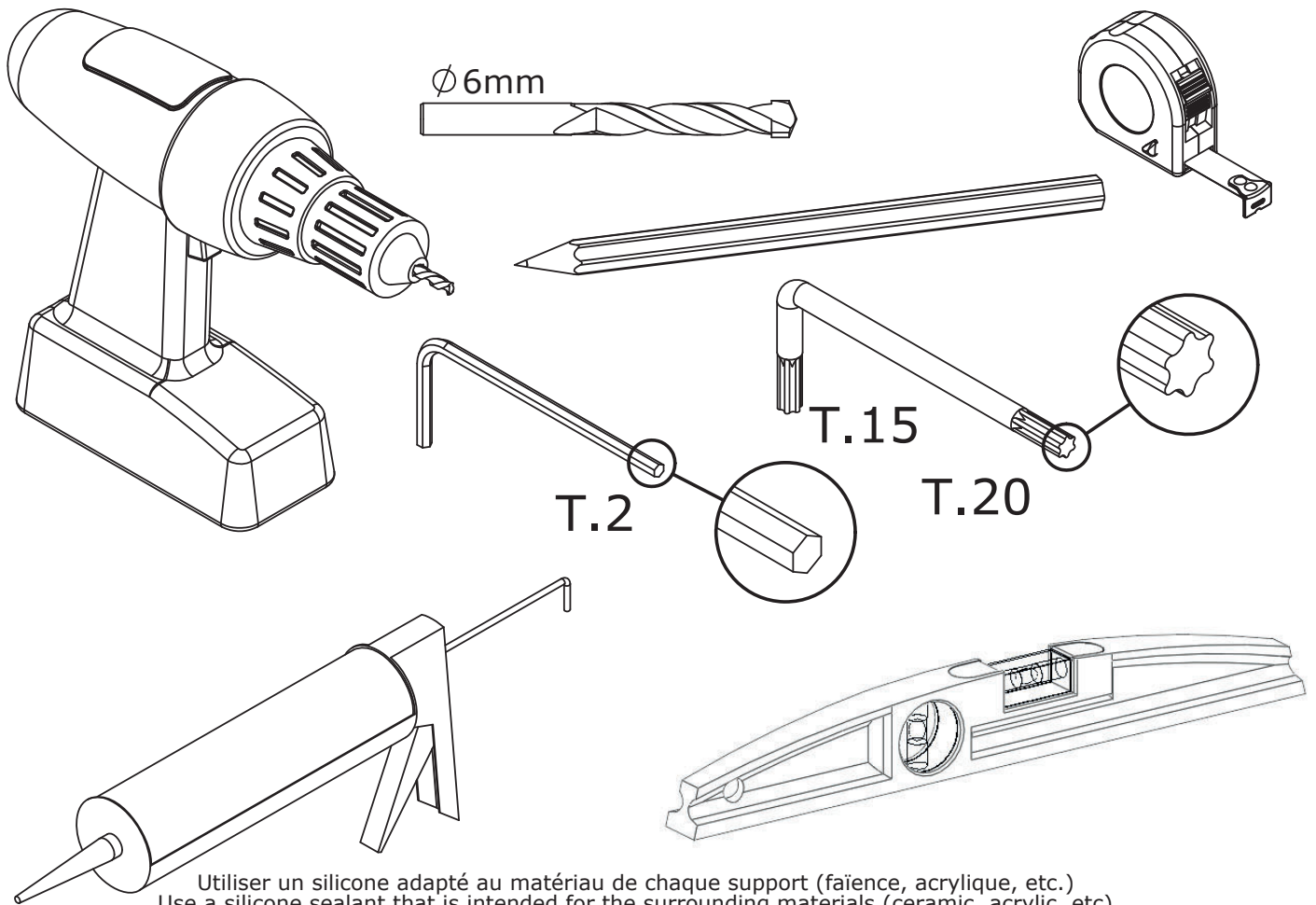

Utiliser un silicone adapté au matériau de chaque support (faïence, acrylique, etc.)  
 Use a silicone sealant that is intended for the surrounding materials (ceramic, acrylic, etc.)  
 Usar una silicona adecuada para cada tipo de material (loza, acrílico, etc.)  
 Usar uma silicona adequada para cada tipo de material (loza, acrílico, etc.)  
 Utilizzare un silicone adatto a qualsiasi materiale (ceramica, acrilico, ecc.)  
 Gebruik siliconenkit die geschikt is voor iedere ondergrond (tegelwerk, acryl, etc.)  
 Für das jeweilige Trägermaterial (Stein, Acryl usw.) geeignetes Silikon verwenden.



REVERSIBILITE - REVERSIBILITY - REVERSIBILIDAD - REVERSIBILIDADE  
 REVERSIBILITA - OMKEERBAARHEID - WAHLWEISE MONTAGE

Montage à gauche  
 Left hand  
 Montaje a la izquierda  
 Montagem à esquerda  
 Montaggio sinistra  
 Montage links  
 Montage links

Montage à droite  
 Right hand  
 Montaje a la derecha  
 Montagem à direita  
 Montaggio a destra  
 Montage rechts  
 Montage rechts



- Vous avez la possibilité de réaliser un montage à droite ou un montage à gauche. Notre notice d'installation décrit un montage à gauche. Si vous voulez réaliser un montage à droite, il vous suffit d'inverser le montage.

- This cubicle can be installed either left or right hand. These installation instructions show a left hand installation.

- Puede realizar un montaje a la derecha o un montaje a la izquierda. Nuestro folleto de instalación describe un montaje a la izquierda. Si desea montar su cabina a la derecha sólo tendrá que realizar el montaje al contrario.

- Pode realizar uma instalação à direita ou uma instalação à esquerda. O nosso manual de instalação descreve uma instalação à esquerda. Se pretende realizar uma instalação à direita, basta inverter a instalação.

- Avete la possibilità di effettuare il montaggio a destra o a sinistra. Il nostro manuale descrive il montaggio a sinistra. Se volete realizzare il montaggio a destra è sufficiente invertire varie fasi di montaggio.

- U kunt de douchecabine rechts of links monteren. Onze handleiding beschrijft de links montage van de cabine. Keer de montage om als u de cabine rechts wilt monteren.

- Sie haben die Möglichkeit, eine Montage auf der linken Seite oder eine Montage auf der rechten Seite durchzuführen. Unsere Montageanleitung beschreibt eine Montage auf der linken Seite. Wenn Sie die Montage lieber auf der rechten Seite durchführen wollen, müssen Sie nur den Montageprozess umkehren.



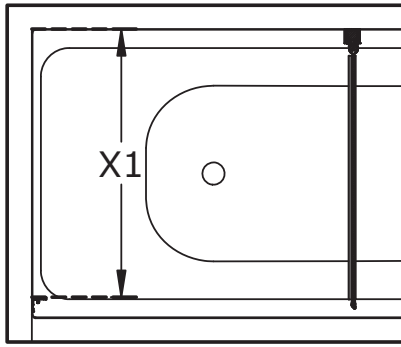

Montage avec retour pivotant  
 Mounting with swivel return  
 Montaje con retorno giratorio  
 Montagem com retorno giratório  
 Montaggio con ritorno girevole  
 Montage met draaibare retour  
 Montage mit schwenkbarem Rücklauf

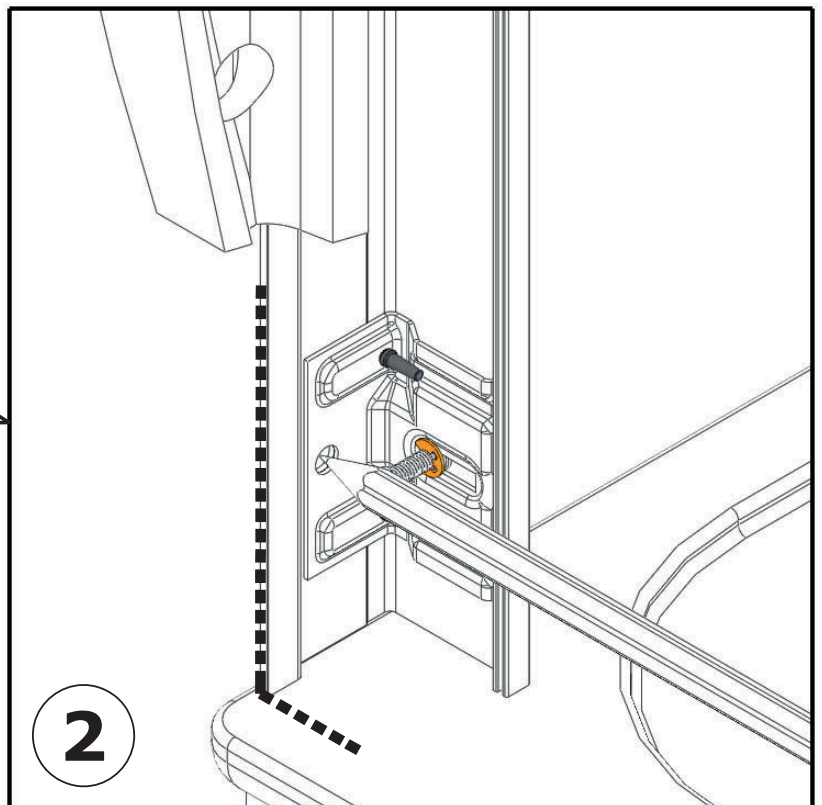
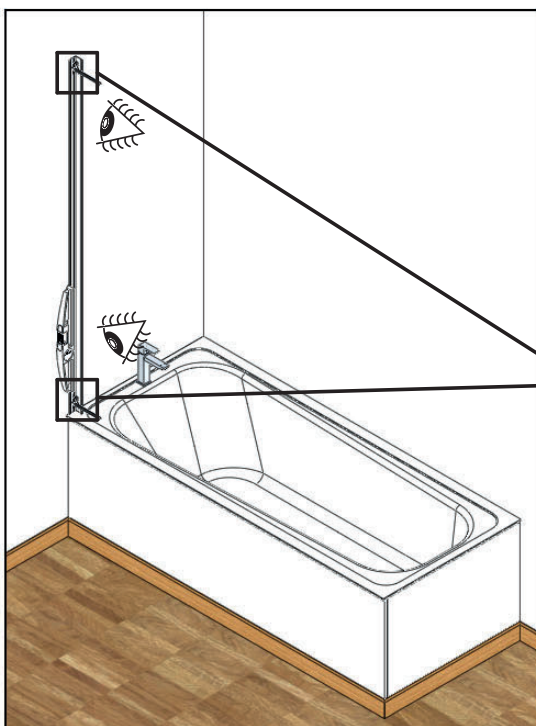
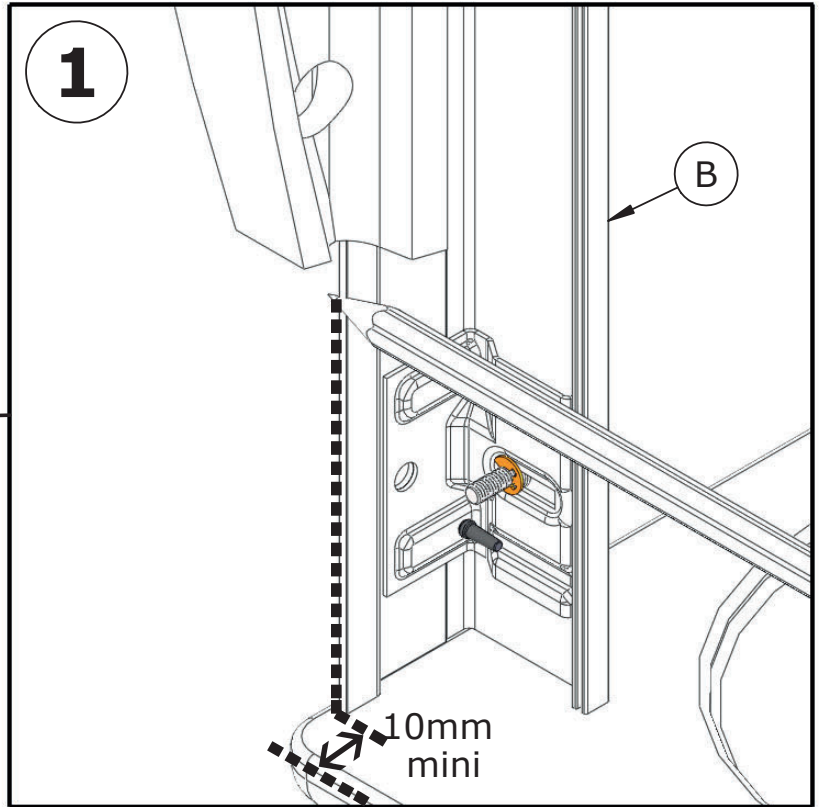
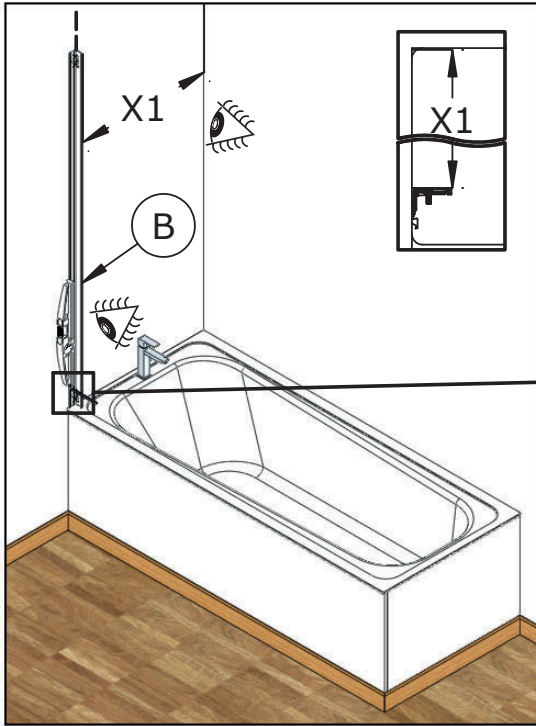

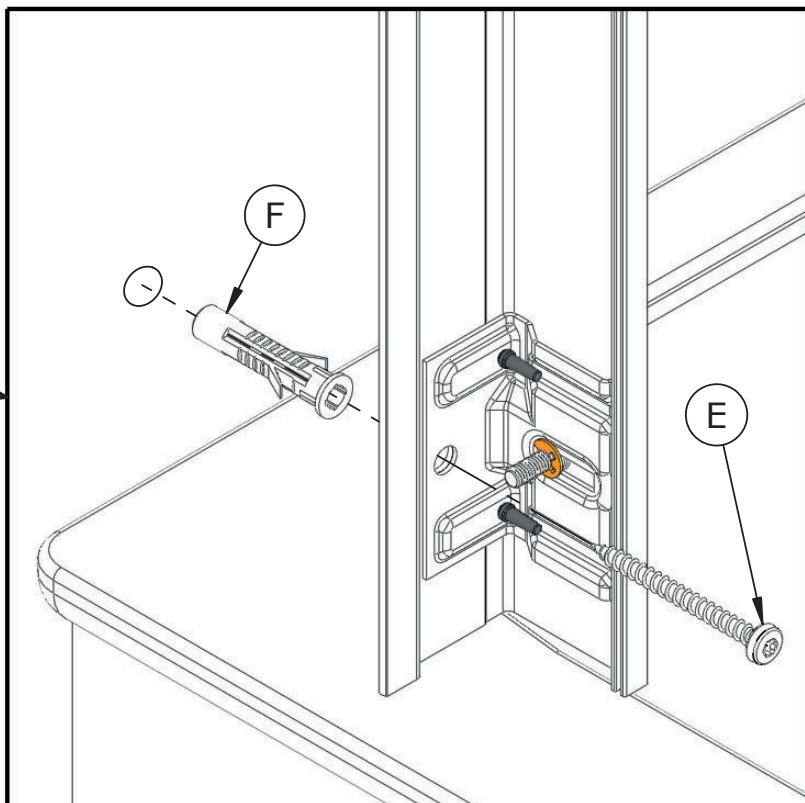
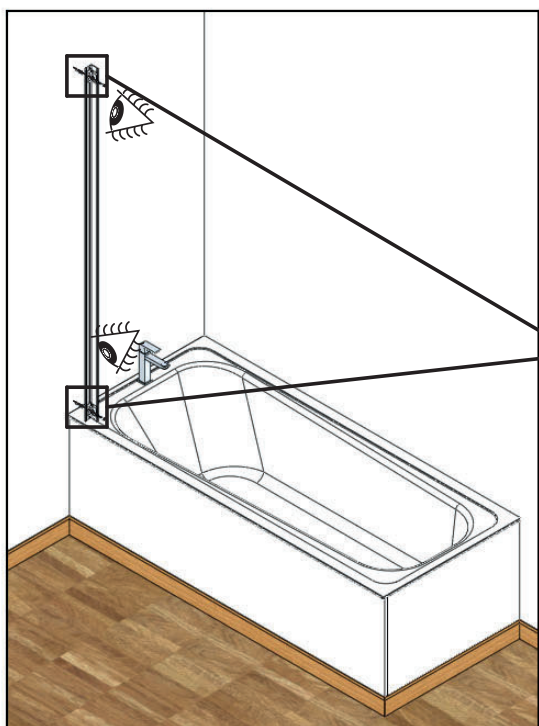
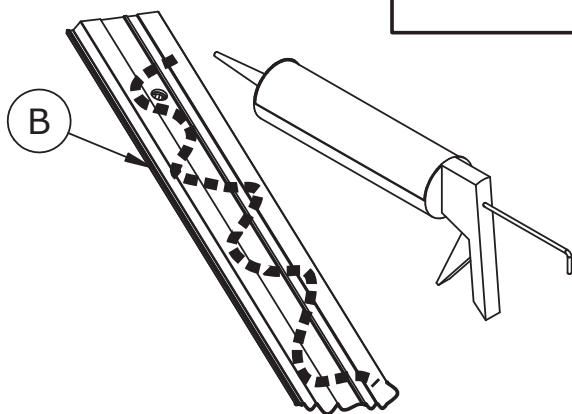
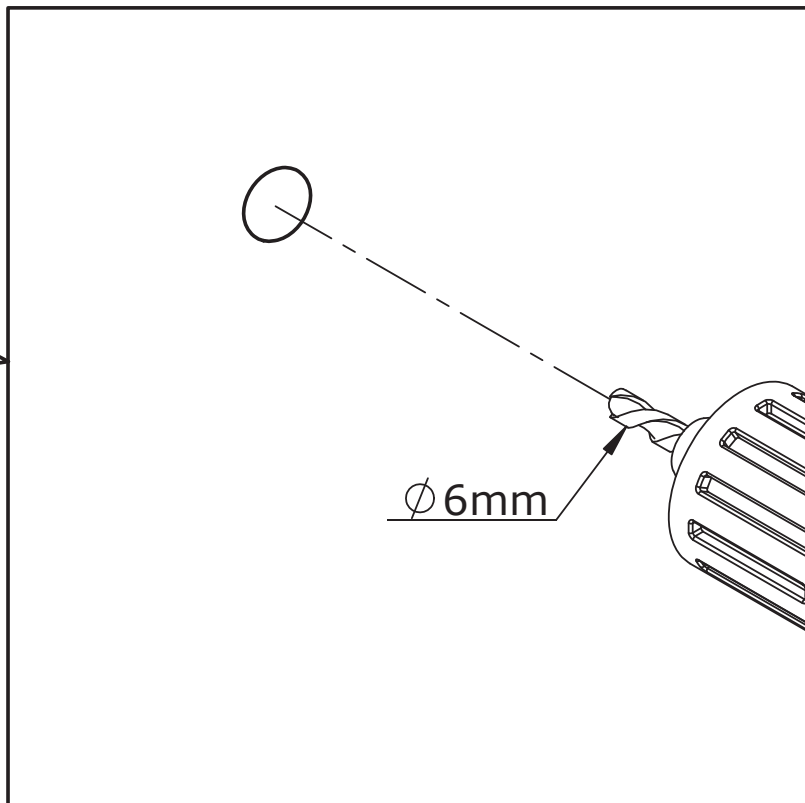
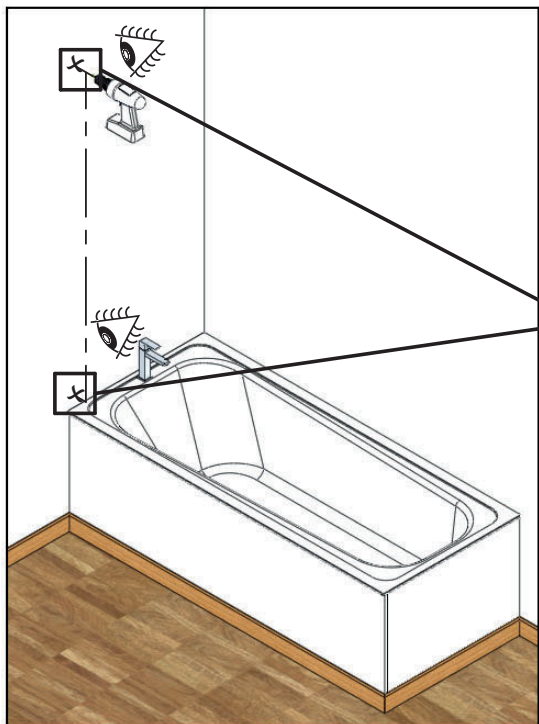

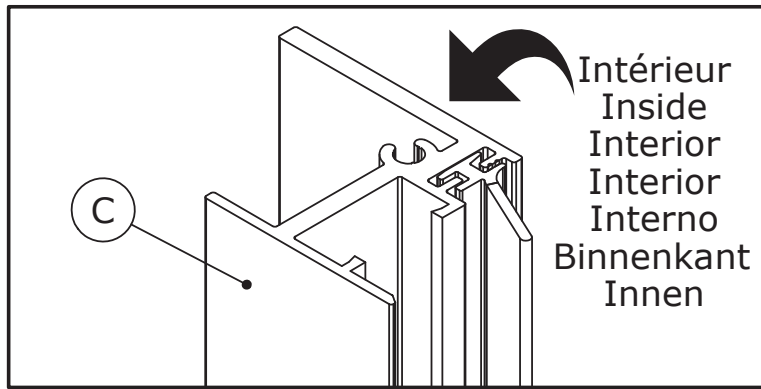
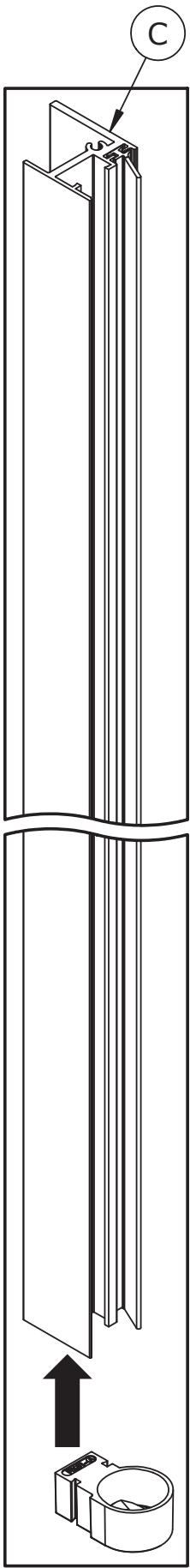

Intérieur  
 Inside  
 Interior  
 Interior  
 Interno  
 Binnenkant  
 Innen

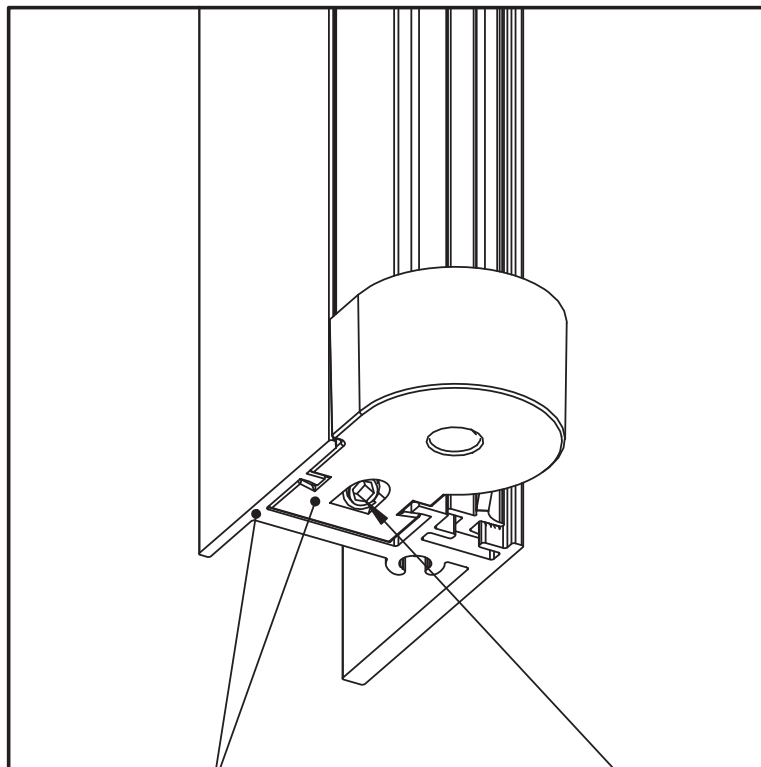
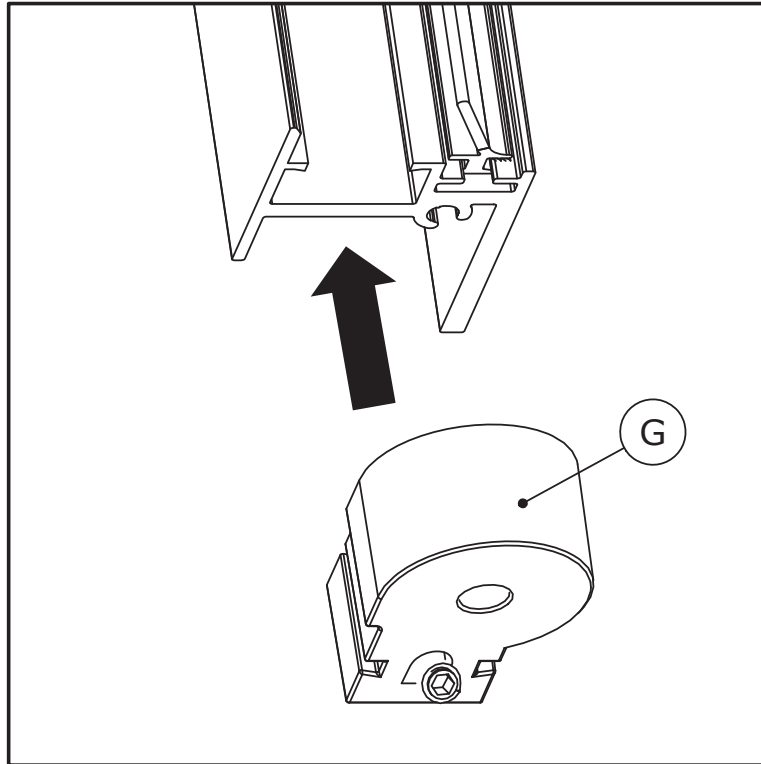

Serrer  
 Tighten  
 Apriete  
 Apertar  
 Serrare  
 Vastdraaien  
 Festziehen



Affleurant - Align  
 Alineado con - Alinhado com  
 A filo - Zijkanten niet laten uitsteken  
 Bündig auszurichtende oberseiten



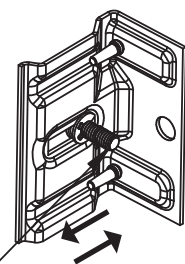
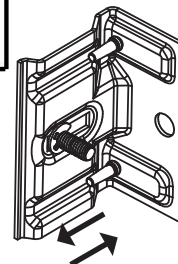
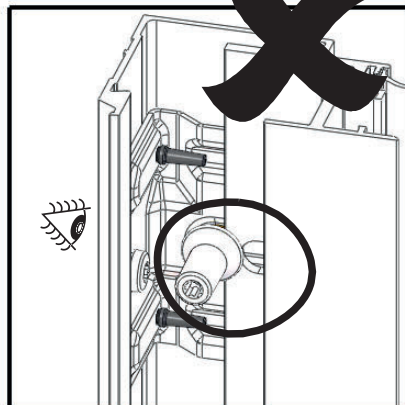
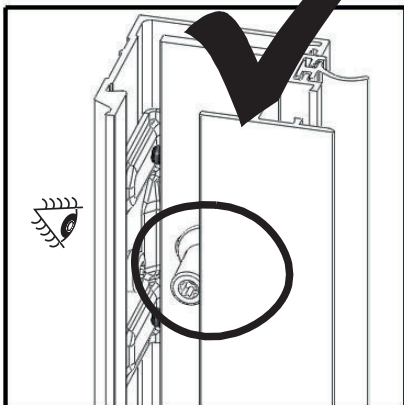
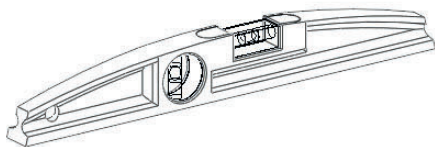
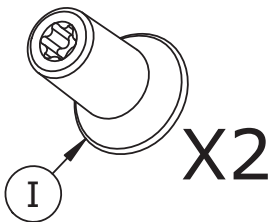
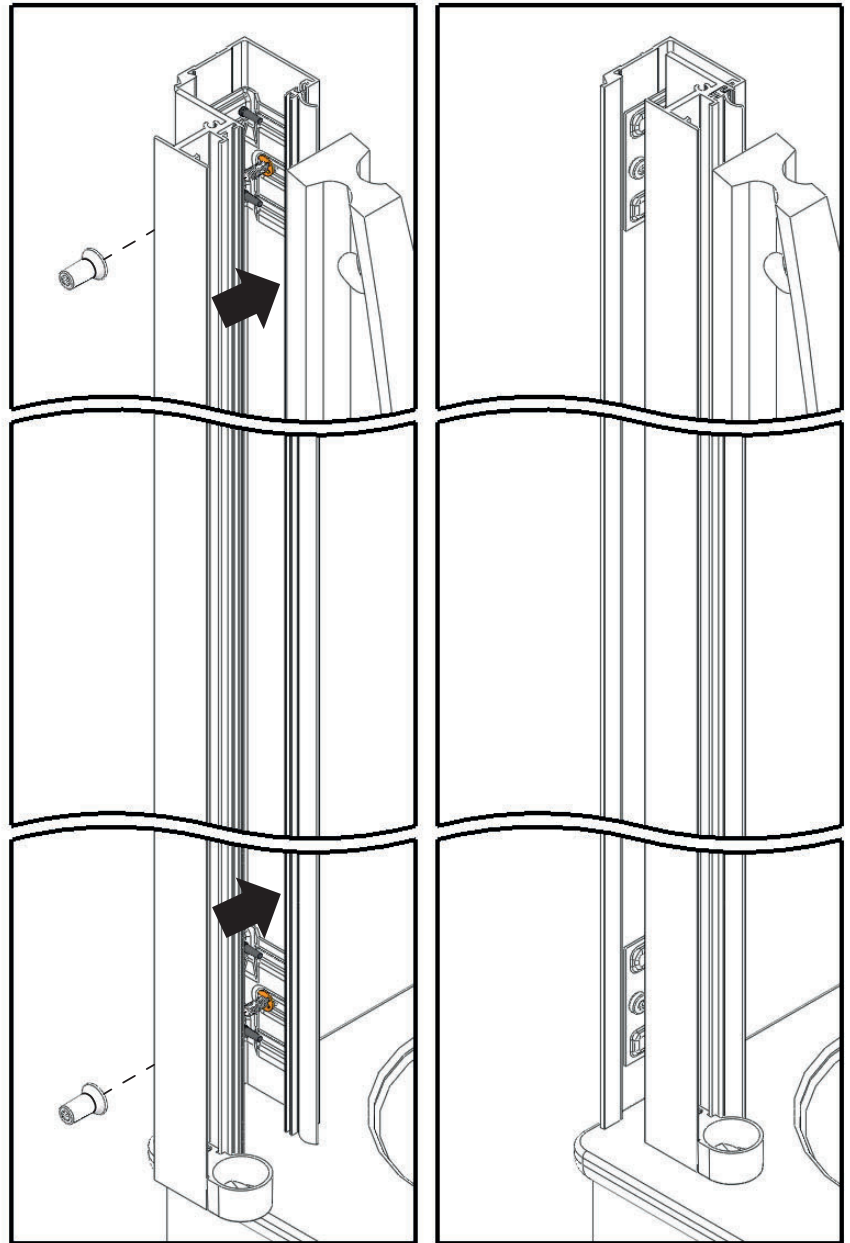
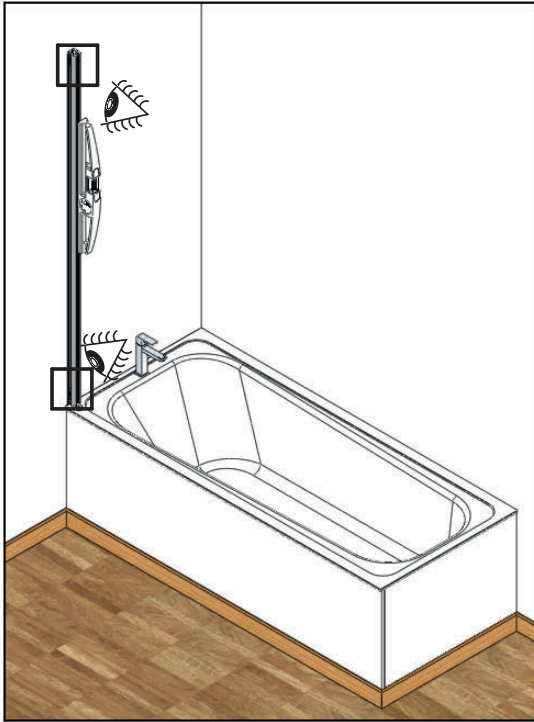

Si nécessaire, desserrer, régler puis resserrer  
 If necessary, loosen, adjust and retighten  
 Si es necesario, afloje, ajuste y apriete  
 Se necessário, desaperte, ajuste e aperte  
 Se necessario, allentare, regolare e stringere  
 Draai los, indien nodig, stel af en draai vervolgens weer vast  
 Falls erforderlich, lösen, einstellen und wieder festziehen

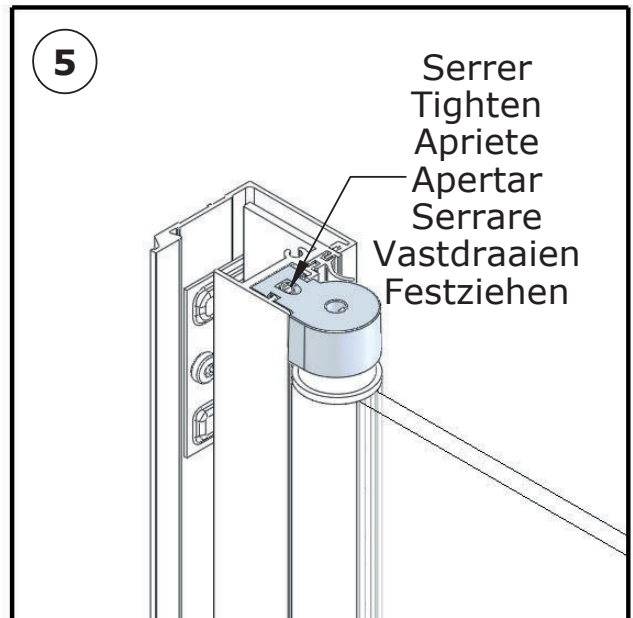
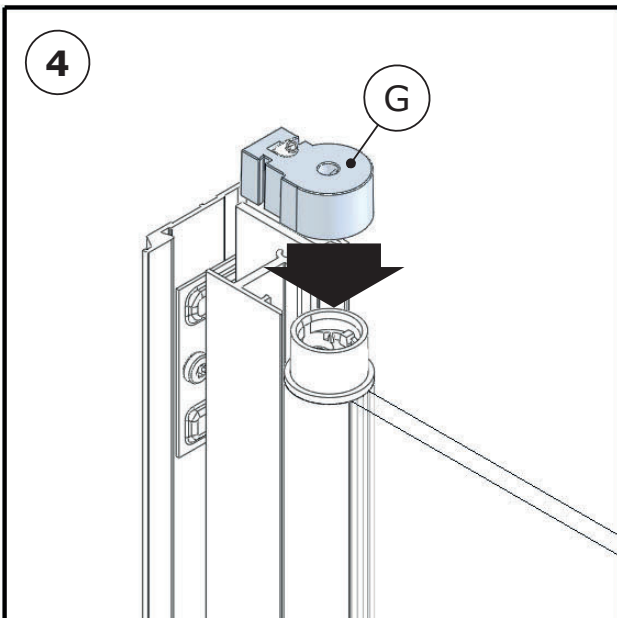
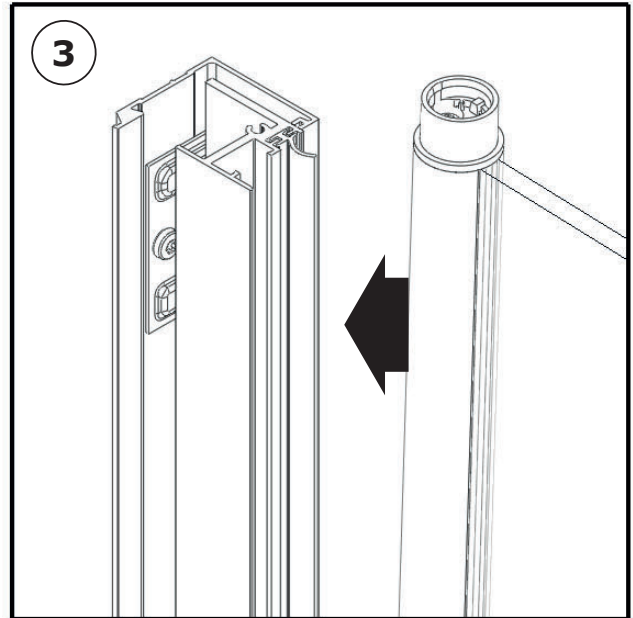
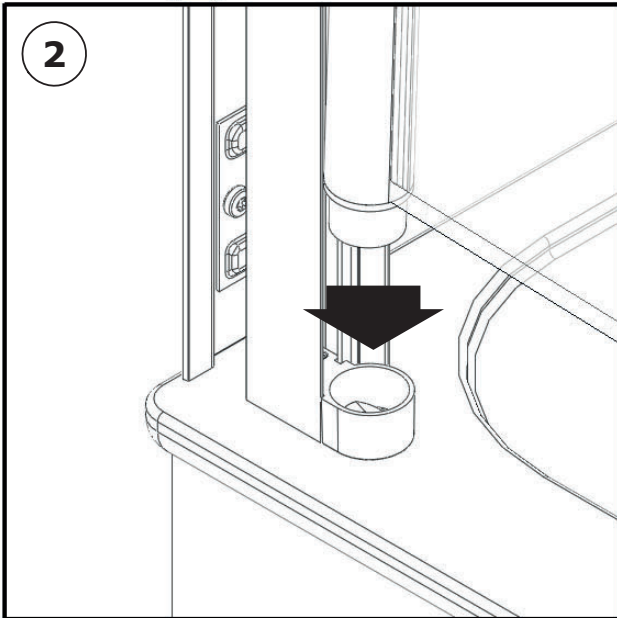
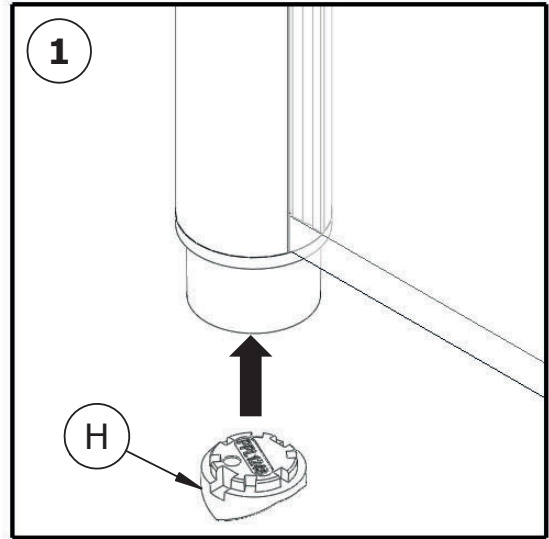
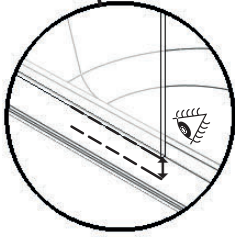
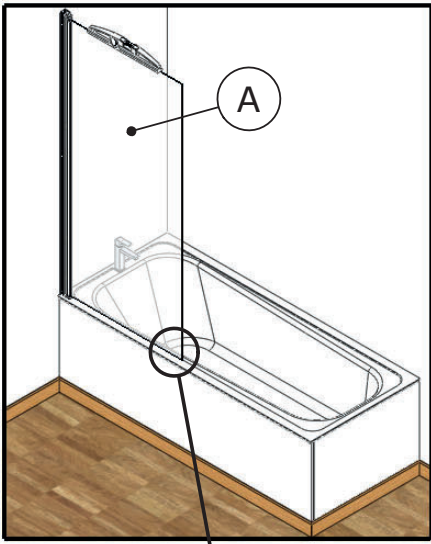

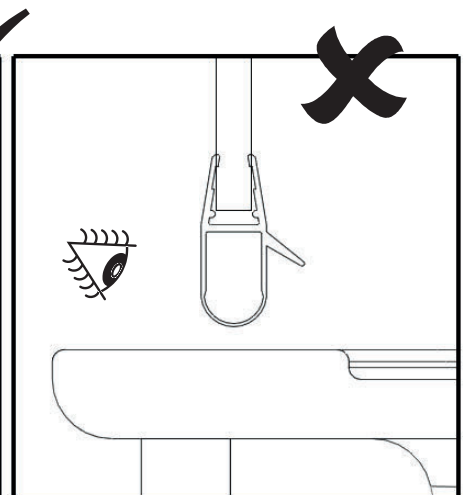
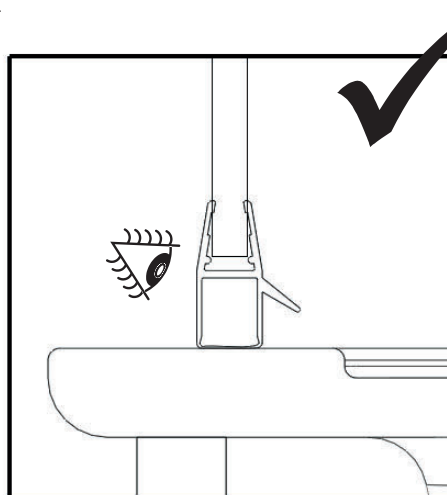
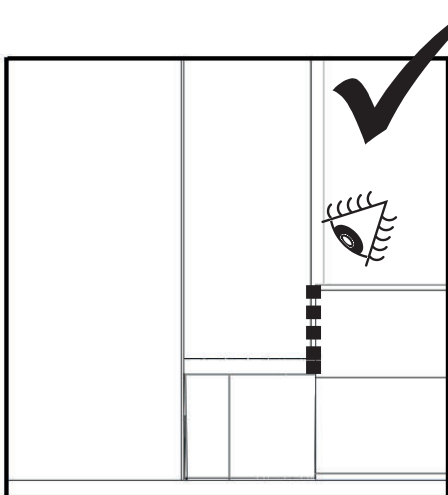
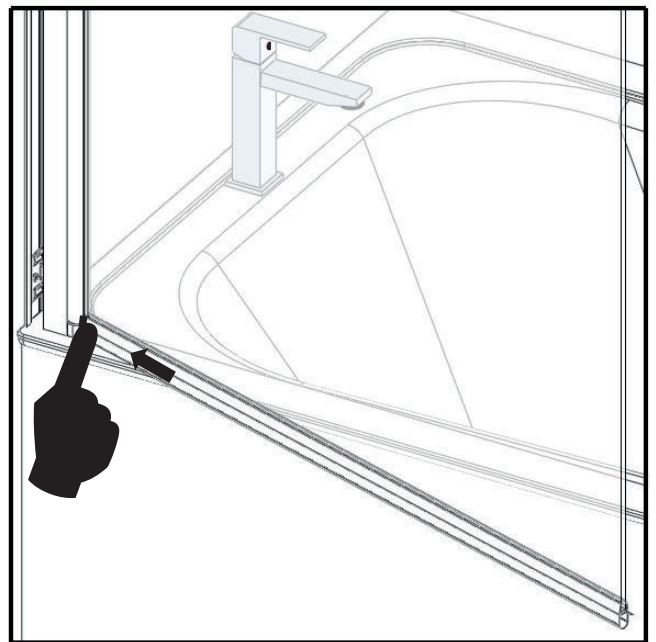
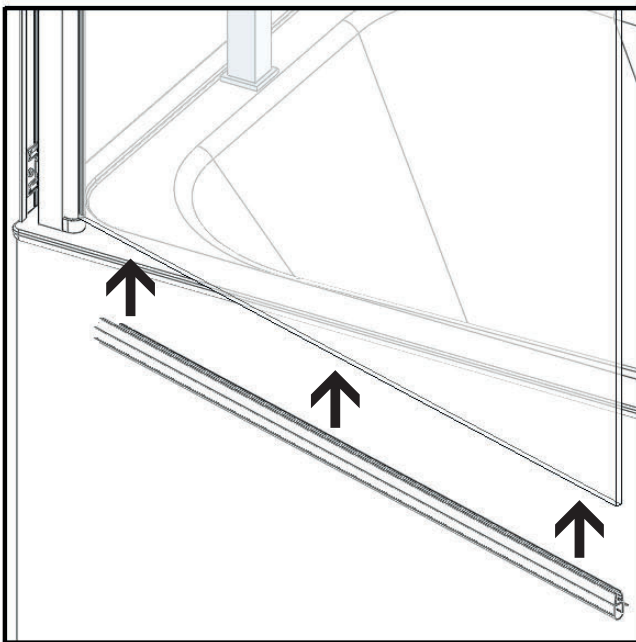
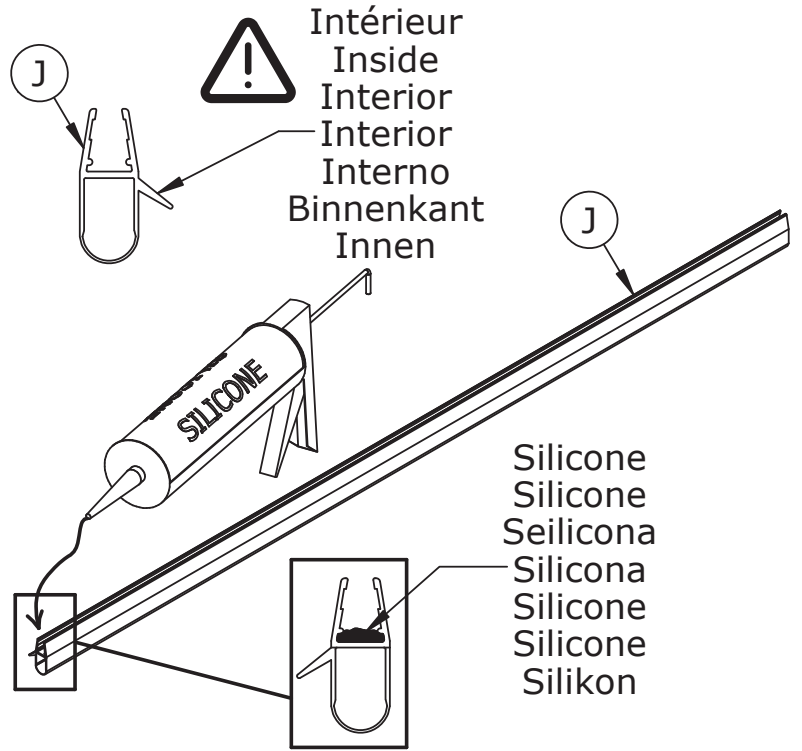

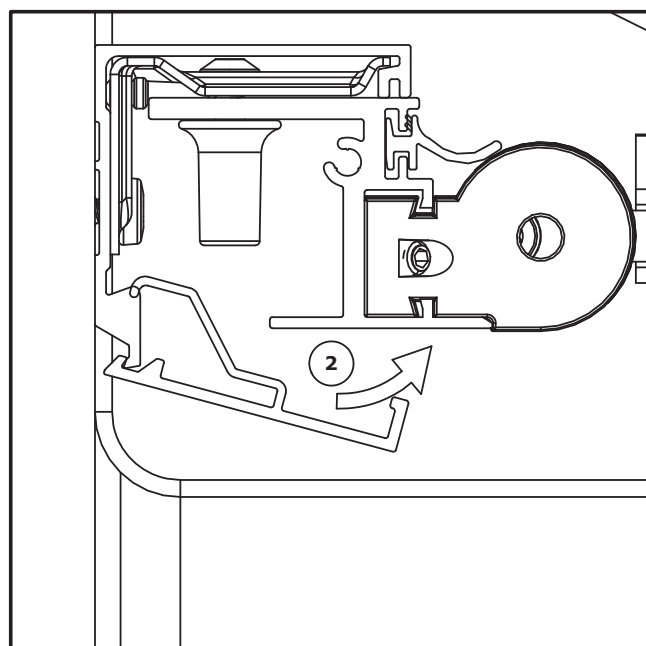
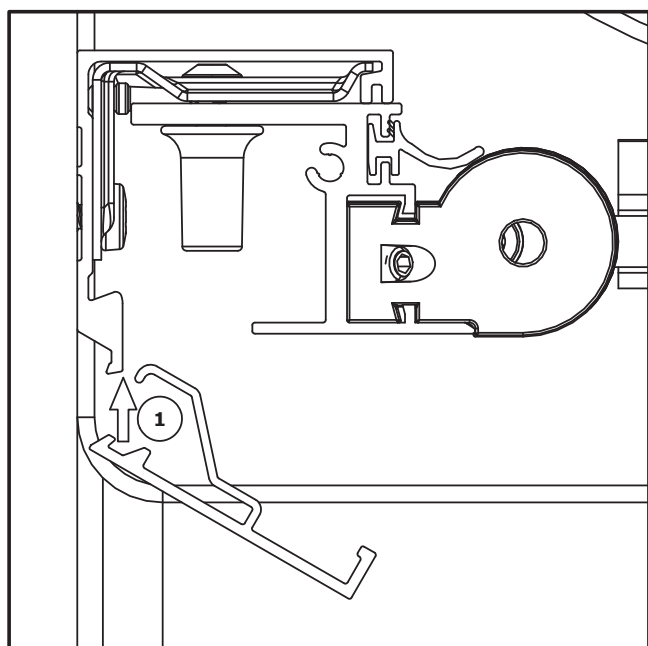
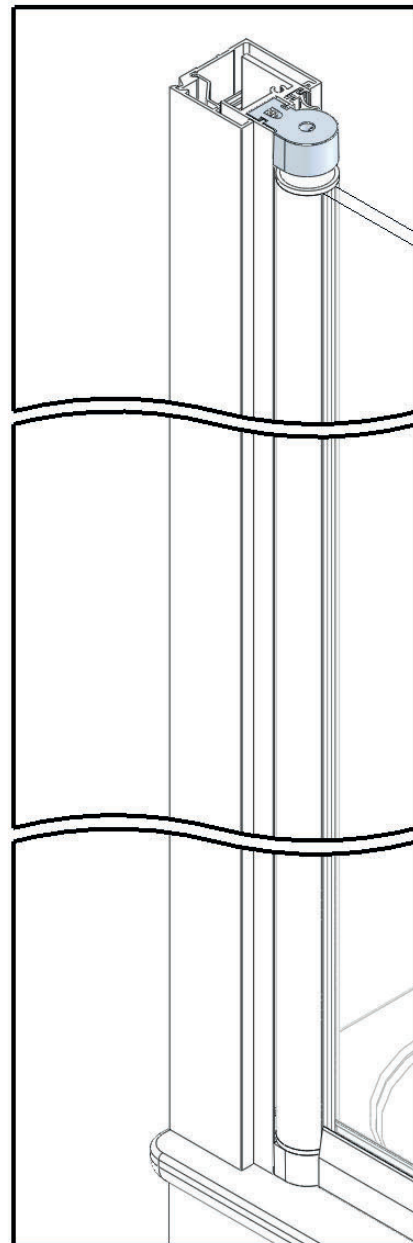
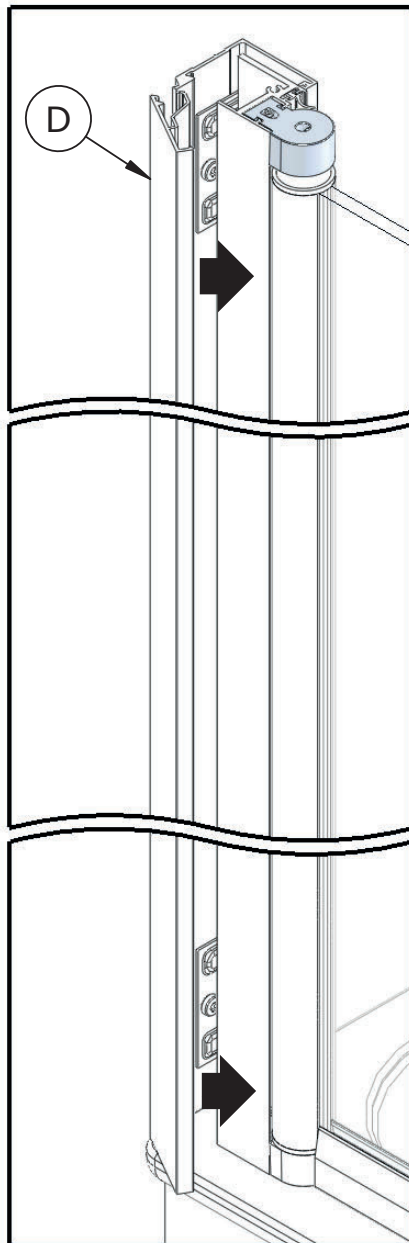
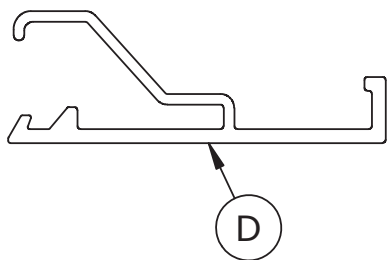

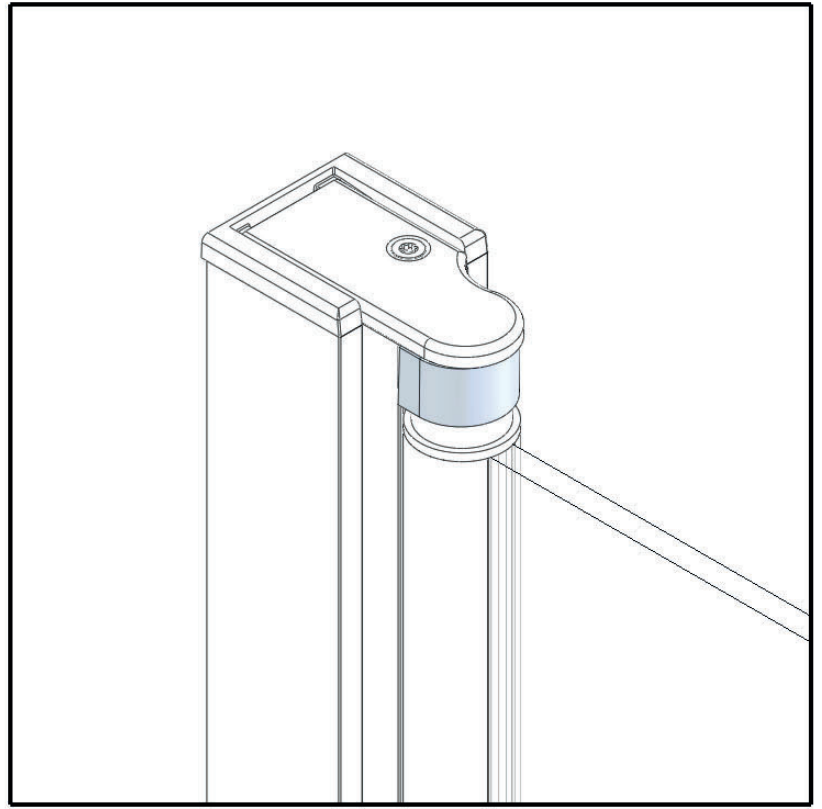
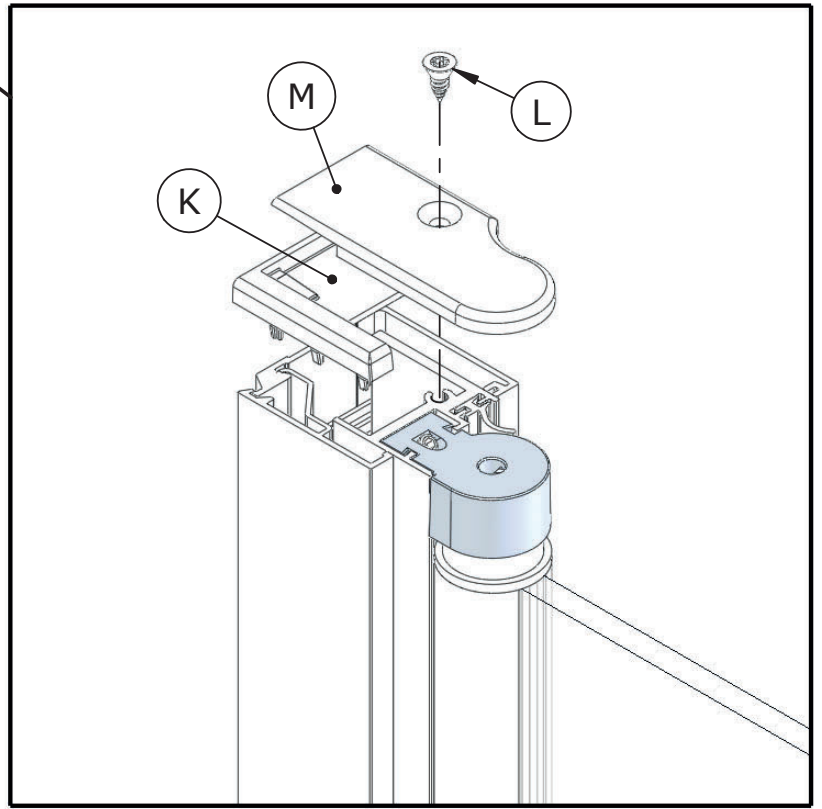
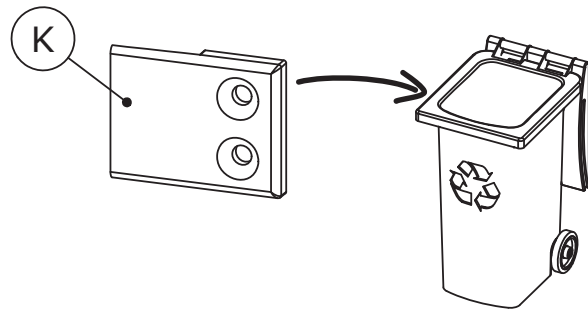



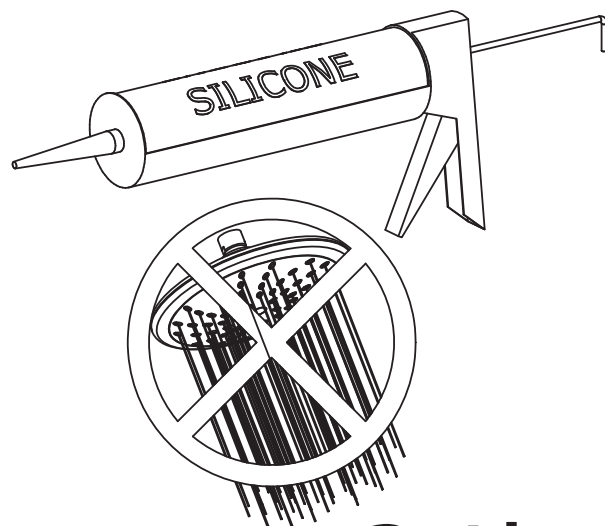
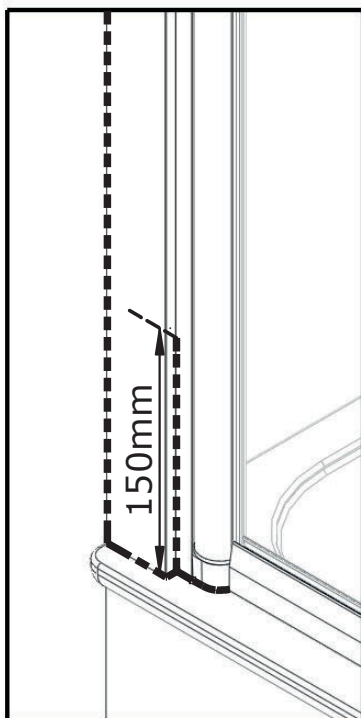
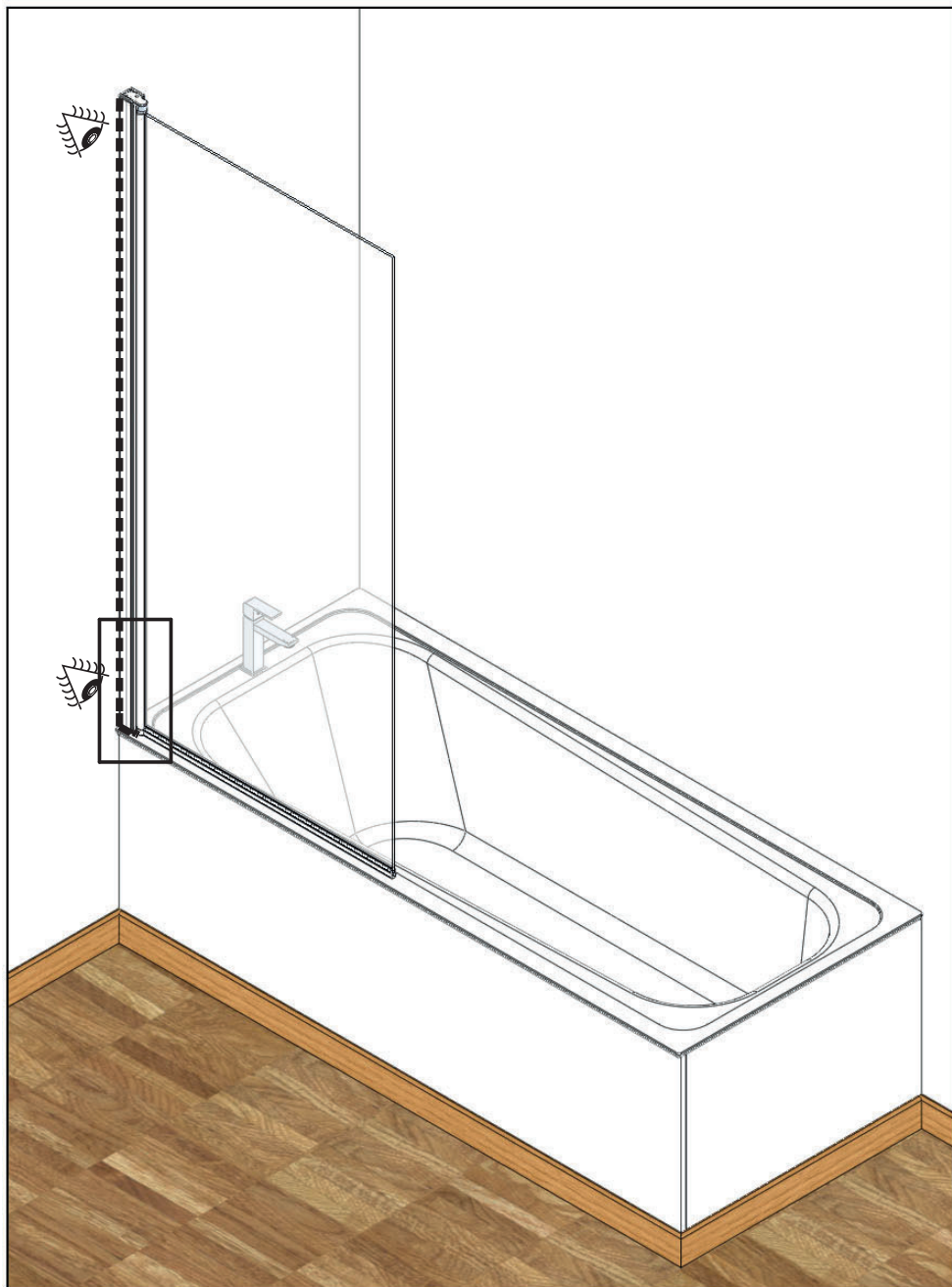
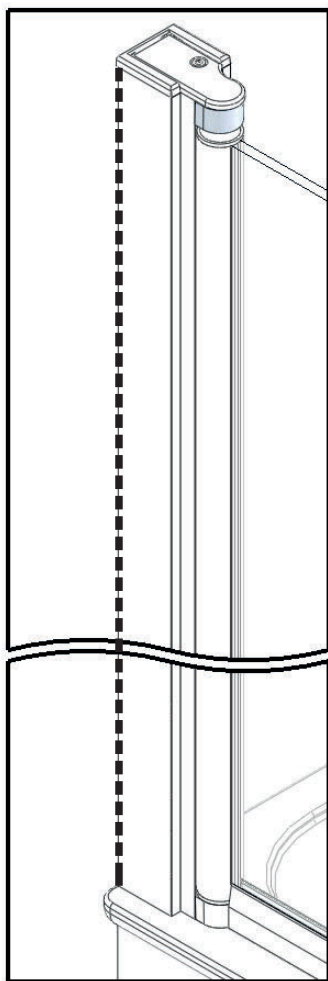

24h

**NOTICE D'ENTRETIEN  
MAINTENANCE INSTRUCTIONS  
ISTRUZIONI DI MANUTENZIONE  
INSTRUCCIONES DE MANTENIMIENTO  
ONDERHOUDSINSTRUCTIE  
WARTUNGSANLEITUNG**

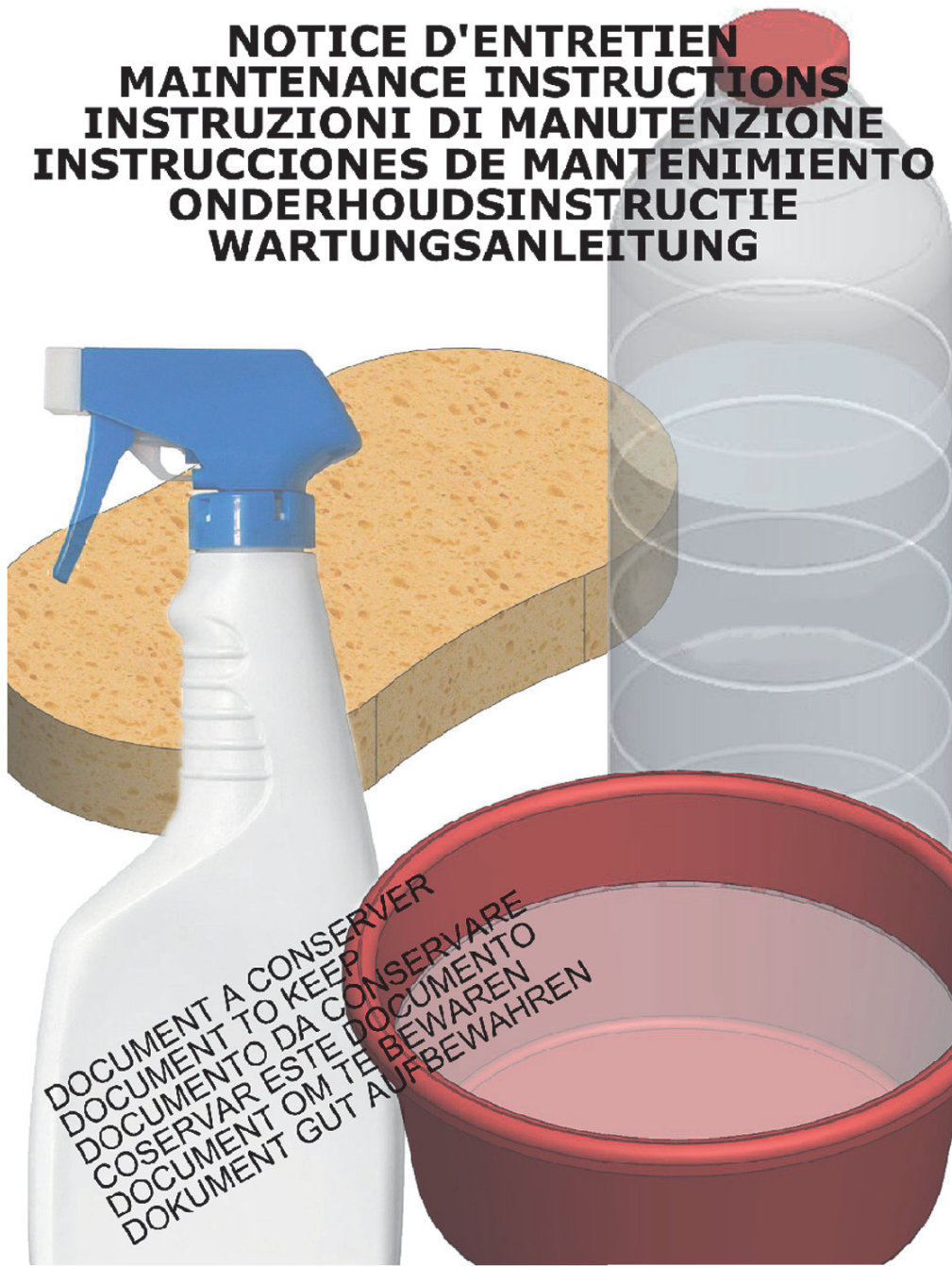

**SCAN ME**





## SERVICE APRÈS-VENTE AFTER-SALES SERVICE

### FRANCE

+33 (0)2 40 21 29 45

### UK

+44 020 8842 0033

### IRELAND

+353 04697 33102

### DEUTSCHLAND

+49 (0) 6074 / 30928 0

### ITALIA

+39 (0382) 6181

### ÖSTEREICH

+43 1 710 60 70

### SUISSE/SCHWEIZ

+41 (01) 748 17 44

### ESPAÑA

+34 93 544 60 76

### NEDERLAND

+31 475 487 100

### BELGIQUE/BELGIË

+31 475 487 100

### РОССИЯ

+7 495 258-29-51

### PORTUGAL

+351 219 112 785



AQUAPRODUCTION, Site industriel,  
F - 44680 Chaumes-en-Retz

22

### EN 14428

Paroi de douche, fabriquée en verre de silicate  
sodo-calcique de sécurité trempé thermiquement

Aptitude au nettoyage : réussite

Résistance à l'impact/propriétés de fragmentation : réussite

Durabilité : réussite