

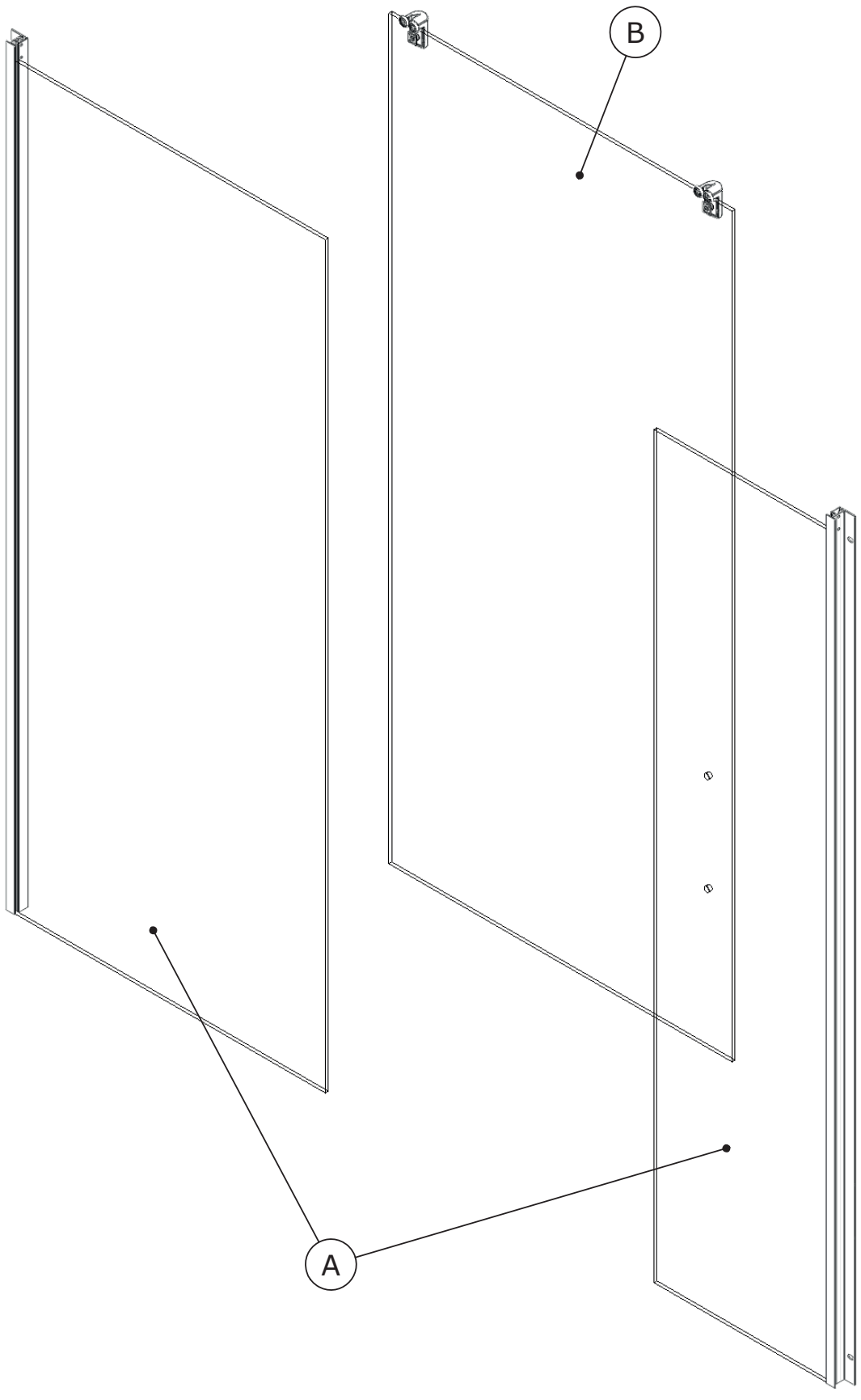







NOTICE DE MONTAGE
INSTALLATION INSTRUCTIONS
MANUAL DE INSTALACION
MANUAL DE INSTALACAO
ISTRUZIONI DI MONTAGGIO
INSTALLATIE VOORSCHRIFTEN
INSTALLATIONSANLEITUNG

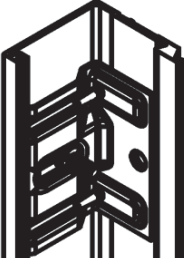
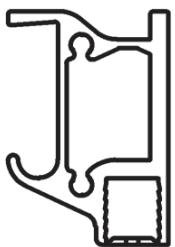

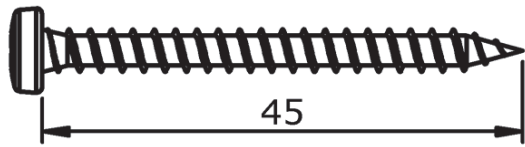
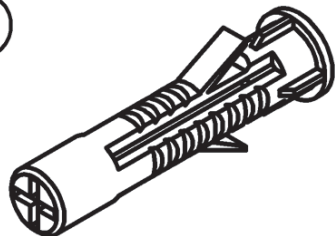
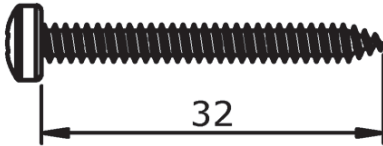

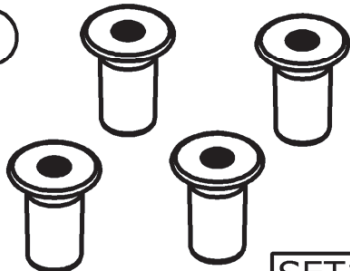
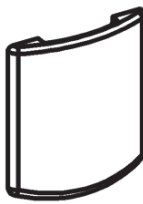
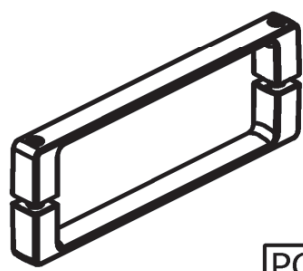
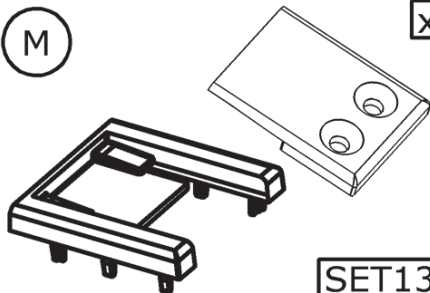
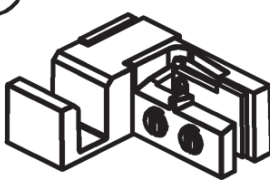
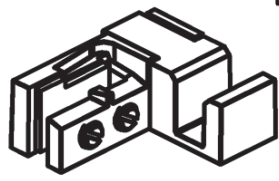
Attention aux étapes :
Check installation steps :
Atención a los pasos:
Atenção aos passos: P:5 - 14 - 17
Attenzione ai passi :
Aandacht voor de stappen :
Achtung vor den Schritten :

DES1541C



<p>(C)  x2</p> <p>LG=1500mm 6268</p>	<p>(D)  x1</p> <p>LG=1496mm LG=1596mm LG=1696mm 6283</p>	<p>(E)  x2</p> <p>LG=1500mm 6270</p>
<p>(F)  $\text{Ø}3,5\text{mm}$ x4</p> <p>45 VIS231</p>	<p>(G)  x4</p> <p>CHE02</p>	<p>(H)  $\text{Ø}3,5\text{mm}$ x4</p> <p>32 VIS214</p>
<p>(I)  $\text{Ø}3,5\text{mm}$ x2</p> <p>9,50 VIS261</p>	<p>(J)  x4</p> <p>SET134</p>	<p>(K)  x2</p> <p>SET135</p>
<p>(L)  x1</p> <p>PGN49</p>	<p>(M)  x2</p> <p>SET137</p>	<p>(N)  x1</p> <p>SET130</p>
<p>(O)  x1</p> <p>Ou - Or O - Ou - O Of - Oder SET131</p>	<p>(P)  x1</p> <p>JOI258</p>	<p>(Q)  x1</p> <p>LG=1460mm J926</p>
<p>(R)  x1</p> <p>LG=1448mm J930</p>		

Les quantités données sont les quantités utiles au montage. les sachets fournis contiennent des pièces supplémentaires.
 The quantities given are what are required for the installation. There may be some surplus in the package provide.
 Las cantidades indicadas son las cantidades necesarias para el montaje. Las bolsitas incluidas contienen piezas suplementarias.
 As quantidades indicadas são as quantidades necessárias para a montagem. Os sacos fechados contêm peças adicionais.
 Le quantità fornite sono le quantità necessarie al montaggio. I sacchetti forniti contengono pezzi supplementari.
 De aangegeven aantallen zijn vereist voor de montage. De verpakking bevat extra onderdelen.
 Die Mengenangaben beziehen sich auf die für die Montage nötigen Teile. Eventuell weitere beige-packte Teile ignorieren.

(S)	x1	(T)	x1	(U)	x1
					
JOI317	LG=1459mm	AI203	LG=1465mm	AI204	

.Les quantités données sont les quantités utiles au montage. les sachets fournis contiennent des pièces supplémentaires.
 .The quantities given are what are required for the installation. There may be some surplus in the package provide.
 .Las cantidades indicadas son las cantidades necesarias para el montaje. Las bolsitas incluidas contienen piezas suplementarias.
 .As quantidades indicadas são as quantidades necessárias para a montagem. Os sacos fechados contém peças adicionais.
 .Le quantità fornite sono le quantità necessarie al montaggio. I sacchetti forniti contengono pezzi supplementari.
 .De aangegeven aantallen zijn vereist voor de montage. De verpakking bevat extra onderdelen.
 .Die Mengenangaben beziehen sich auf die für die Montage nötigen Teile. Eventuell weitere beige packte Teile ignorieren.

Matériel nécessaire - Tools required
Equipamiento necesario - Equipamento necessário
Materiale necessario - Benodigd gereedschap - Benötigte Werkzeuge

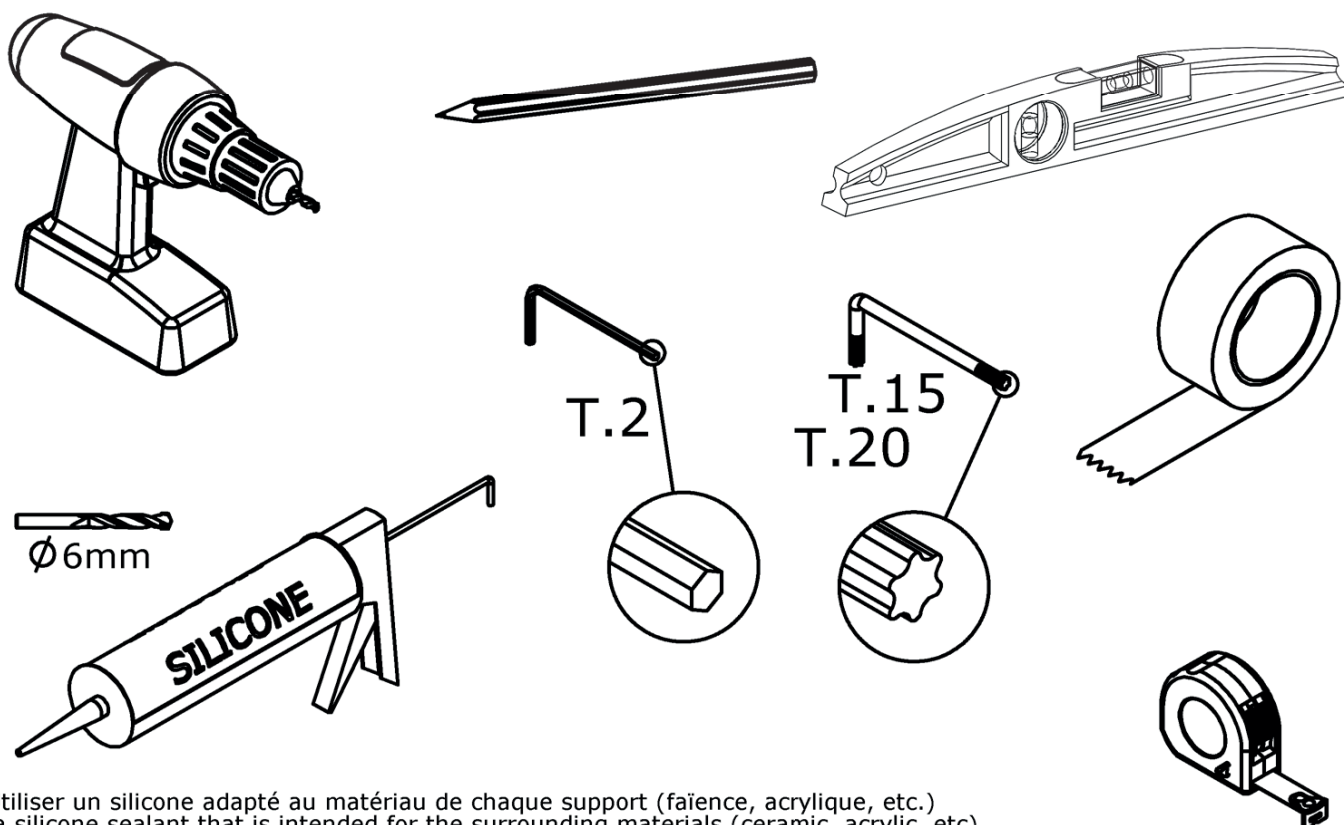

Utiliser un silicone adapté au matériau de chaque support (faïence, acrylique, etc.)
 Use a silicone sealant that is intended for the surrounding materials (ceramic, acrylic, etc.)
 Usar una silicona adecuada para cada tipo de material (loza, acrílico, etc.)
 Usar uma silicona adequada para cada tipo de material (loza, acrílico, etc.)
 Utilizzare un silicone adatto a qualsiasi materiale (ceramica, acrilico, ecc.)
 Gebruik siliconenkit die geschikt is voor iedere ondergrond (tegelwerk, acryl, etc.)
 Für das jeweilige Trägermaterial (Stein, Acryl usw.) geeignetes Silikon verwenden.



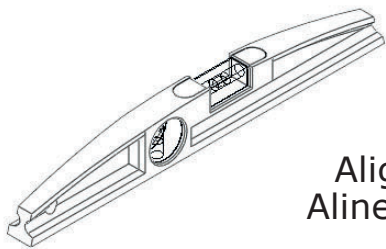
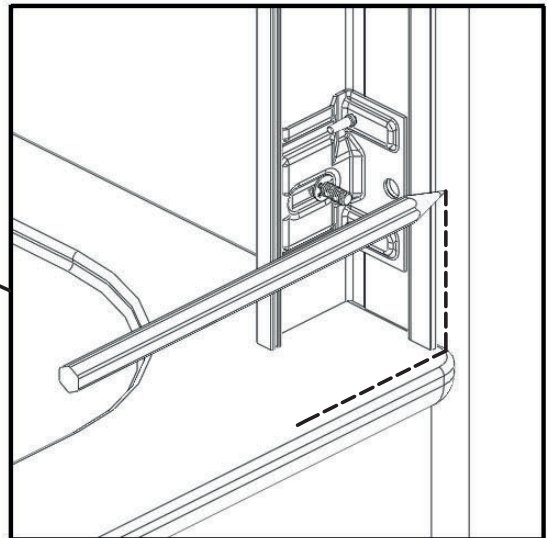
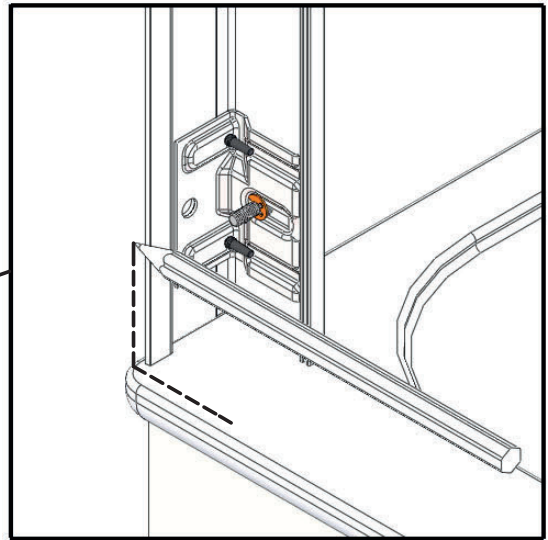
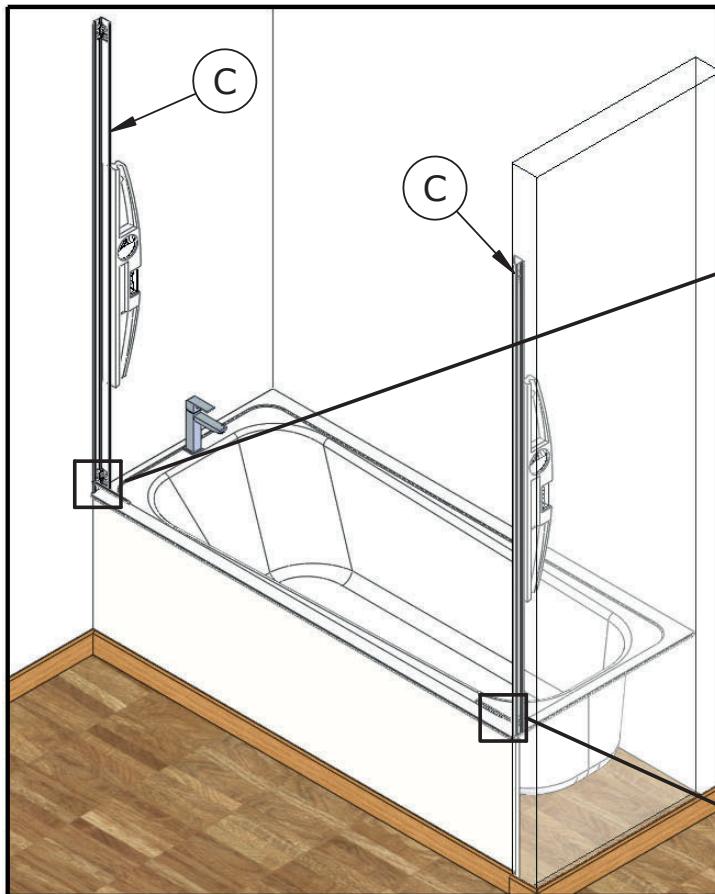

Aligner les profiles - Align profiles
 Alinear los perfiles - Alinhar os perfis
 Allineare i profili

Profielen uitlijnen - Richten Sie die Profile aus

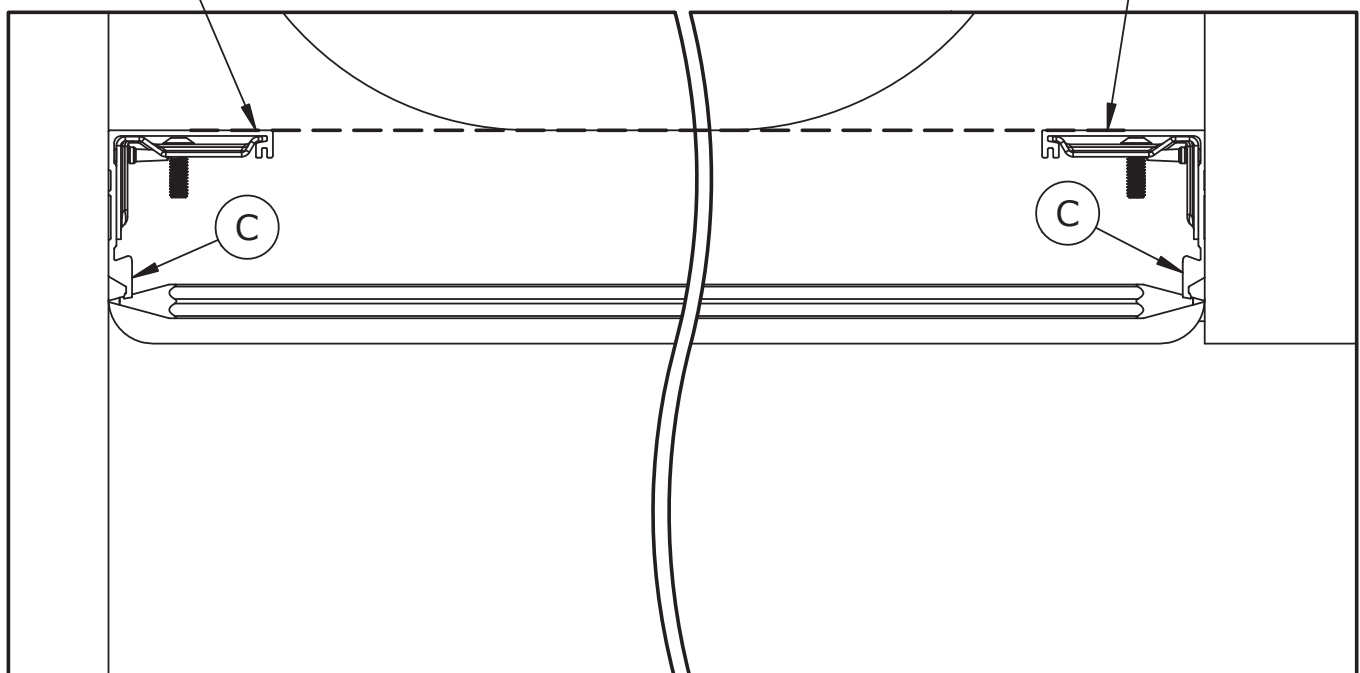

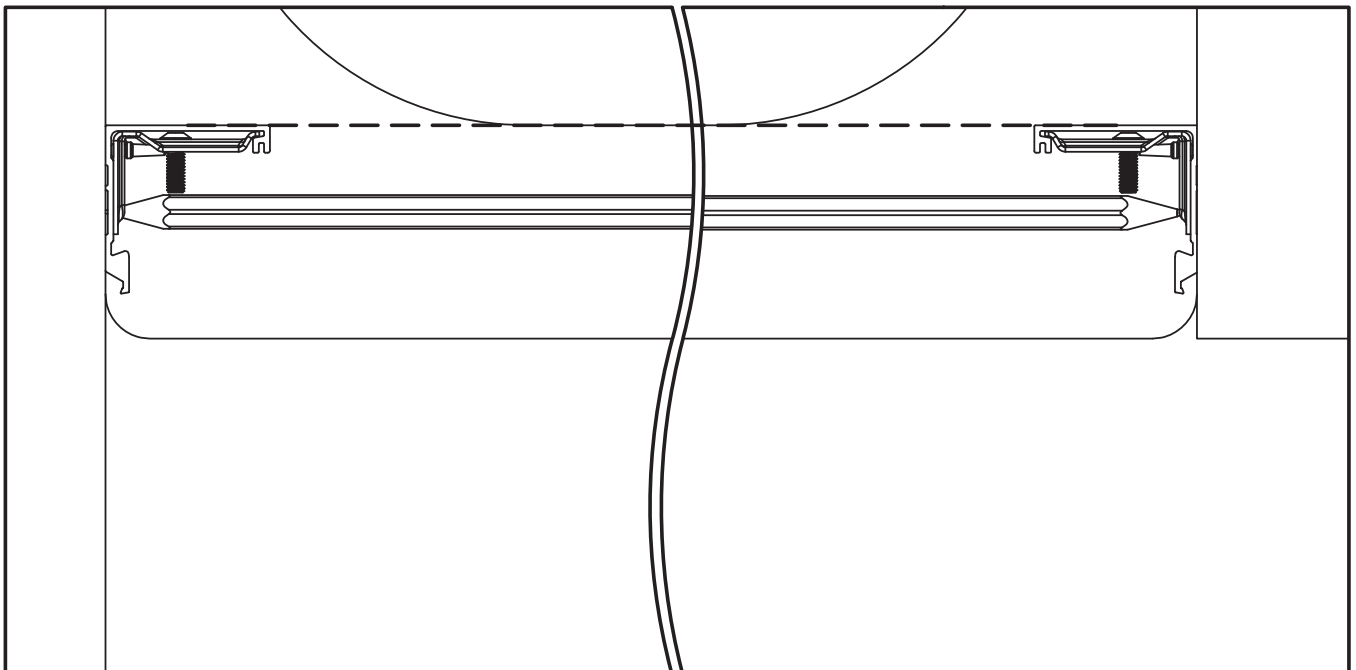
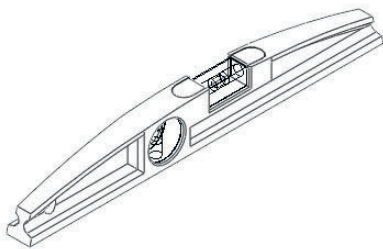
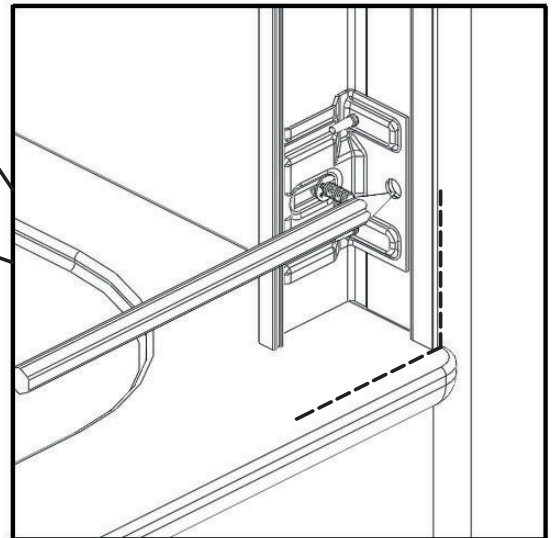
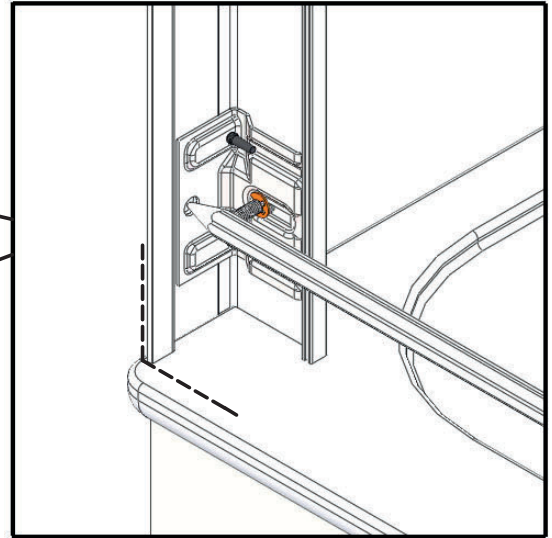
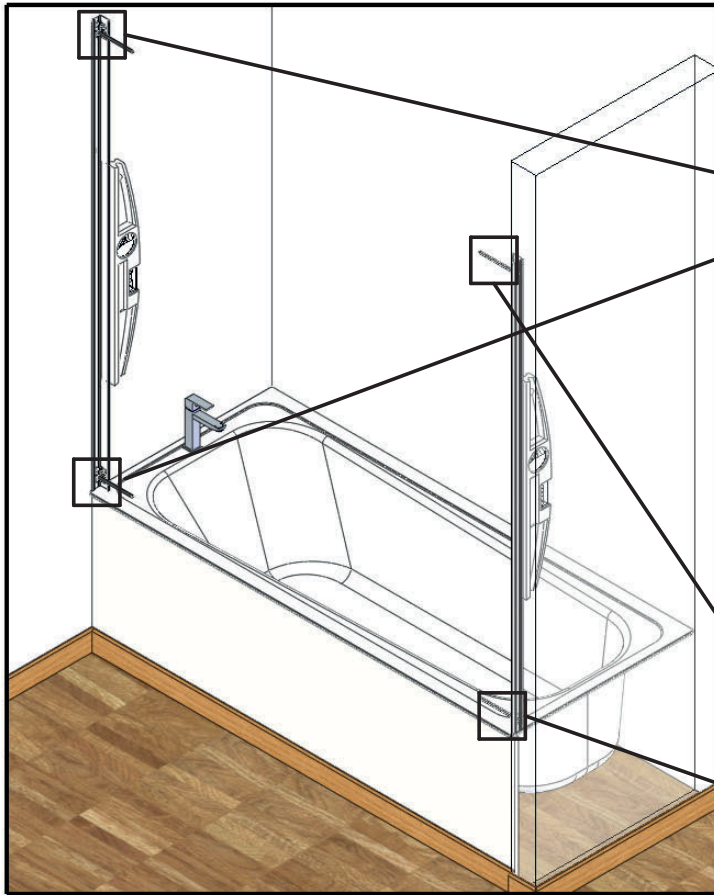

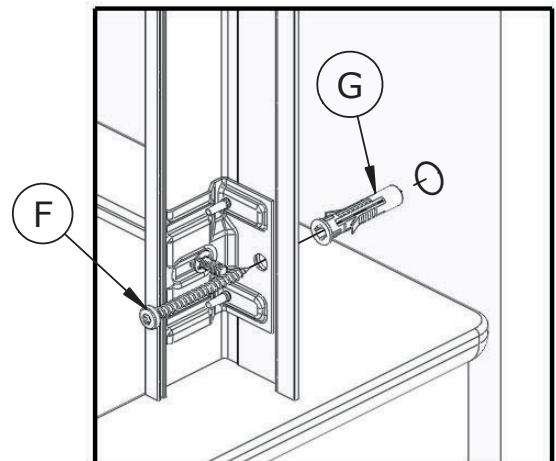
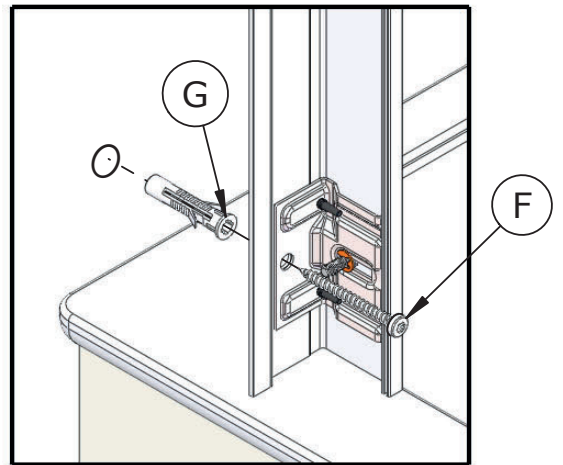
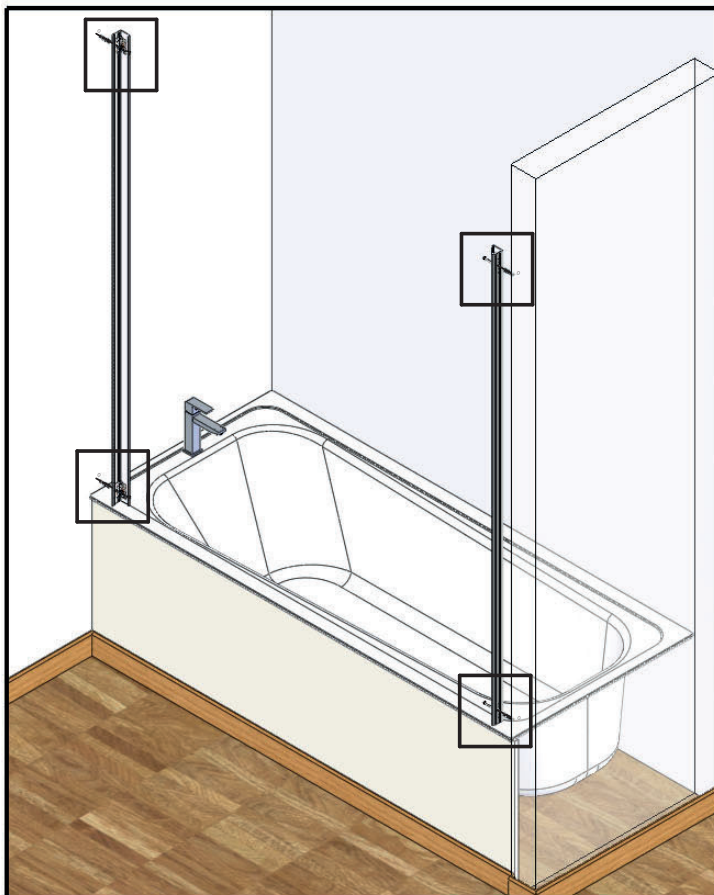
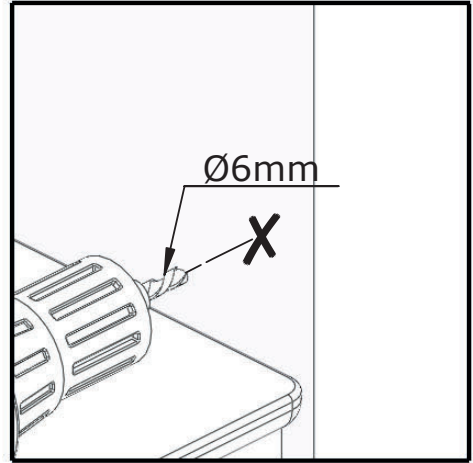
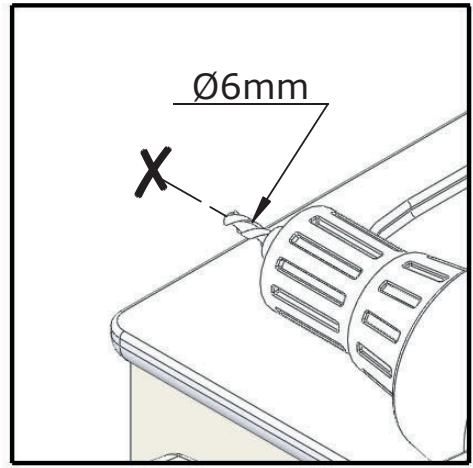
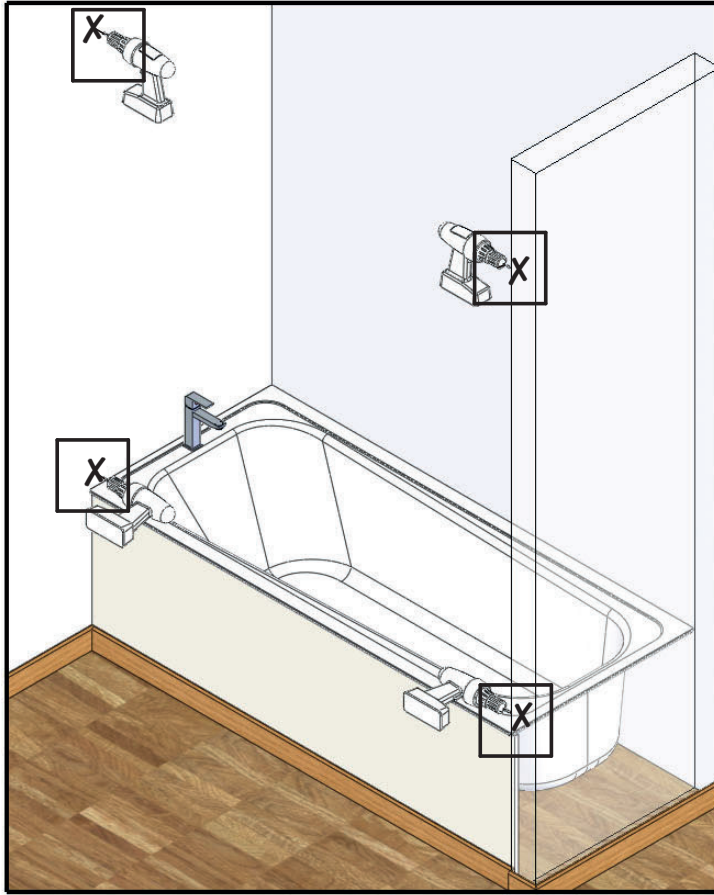

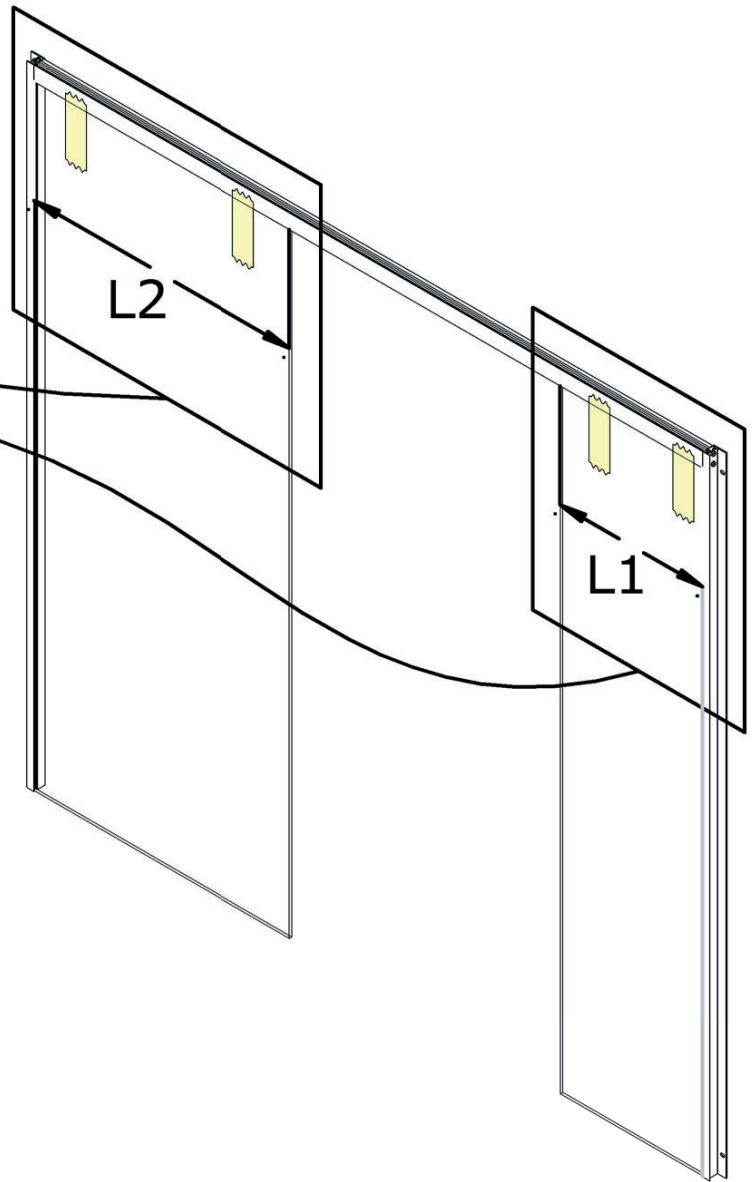
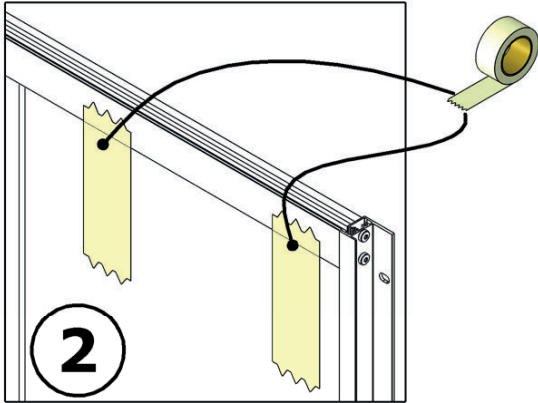
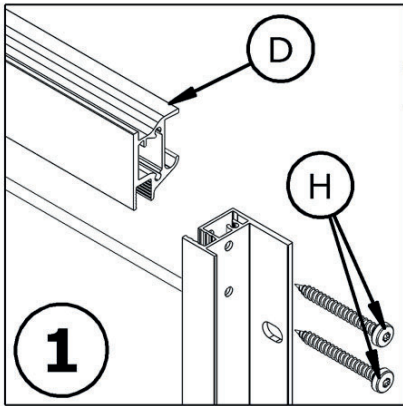
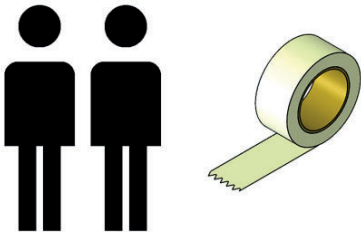

Extérieur - Outside - Exterior -
 Exterior
 - Esterno - Buienkant - Außen

	Taille - measure Medida - Misura Maat - Größe (mm)	S	
		L1	L2
	1600	258	588
	1700		688
	1800		688

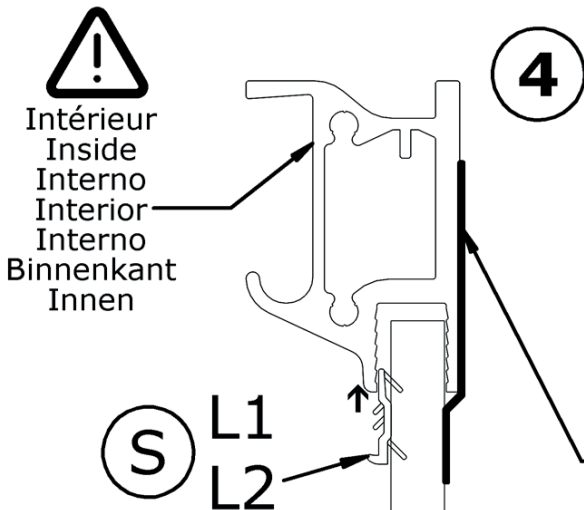
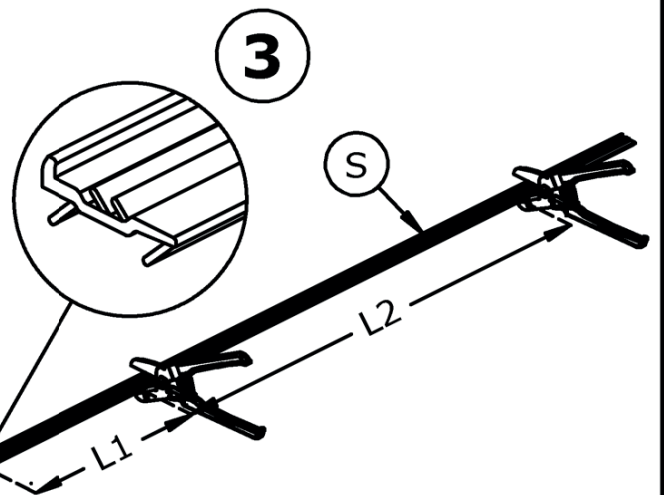

Intérieur
 Inside
 Interno
 Interior
 Interno
 Binnenkant
 Innen

Ruban adhésif
 Adhesive tape
 Cinta adhesiva
 Fita adesiva
 Nastro adesivo
 Plakband
 Klebeband

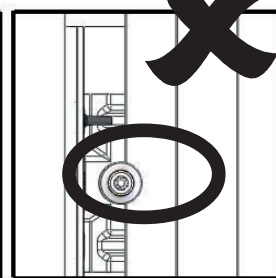
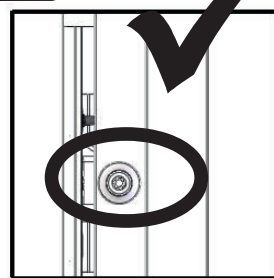
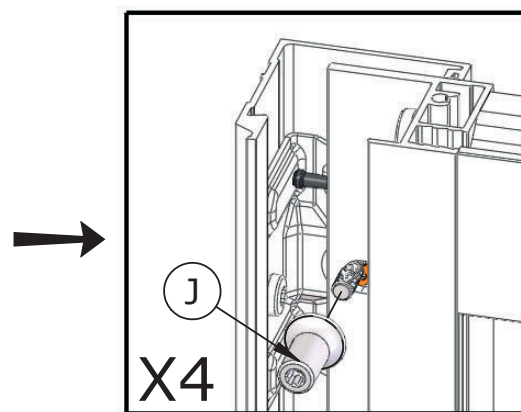
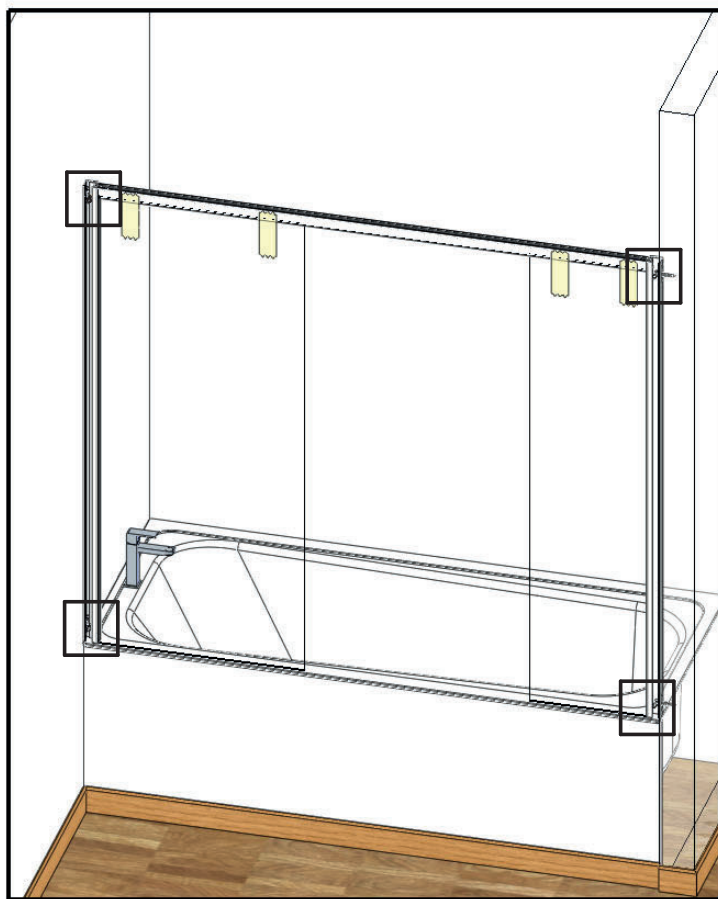

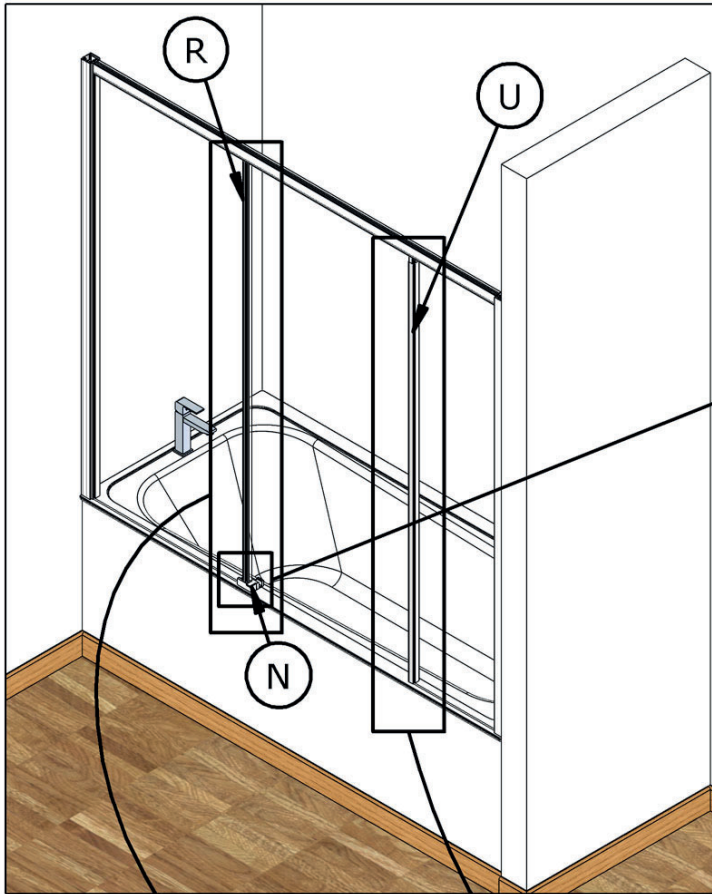

1

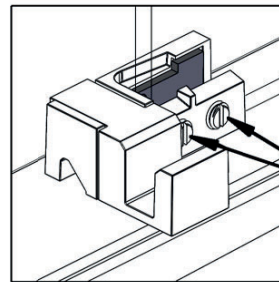
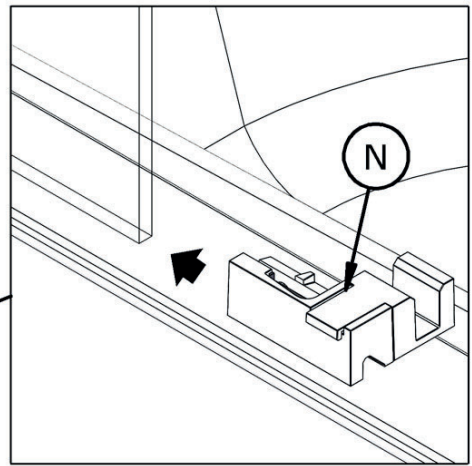

Serrer
Tighten
Apriete
Apertar
Serrare
Vastdraaien
Festziehen

Intérieur - Inside
Interno - Interior
Inetno
Binnenkant - Innen

2

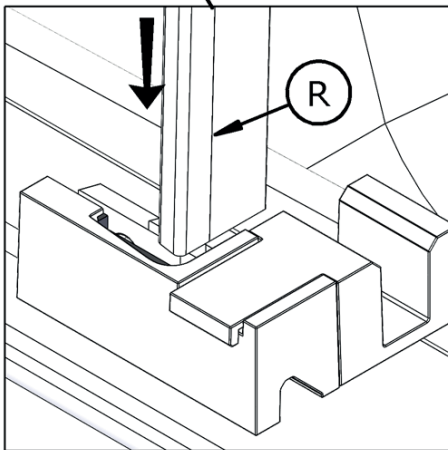

Intérieur - Inside
Interno - Interior
Inetno
Binnenkant - Innen

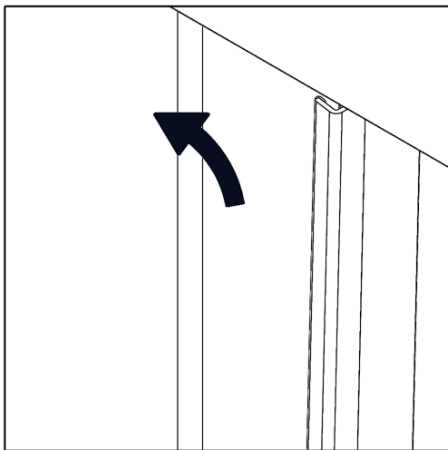

Intérieur - Inside
Interno - Interior
Inetno
Binnenkant - Innen

3

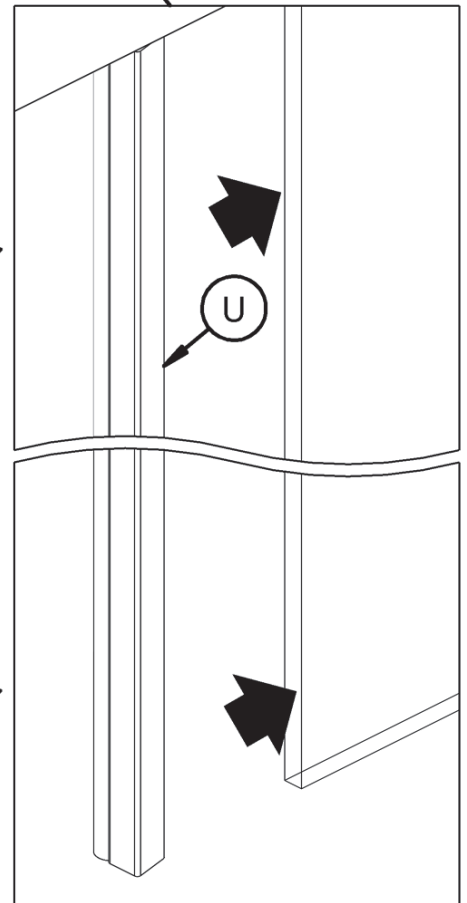

R



U

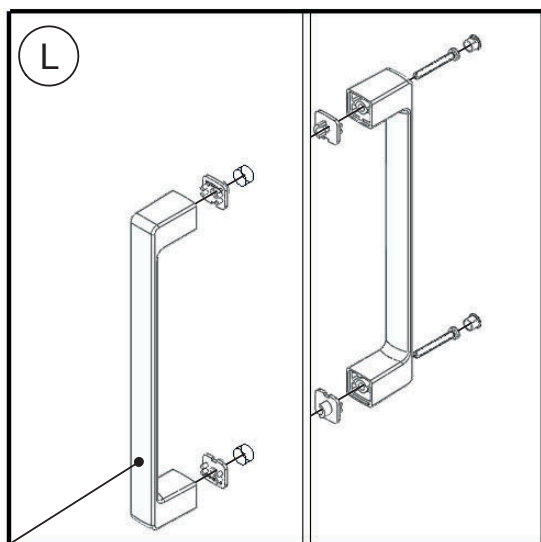
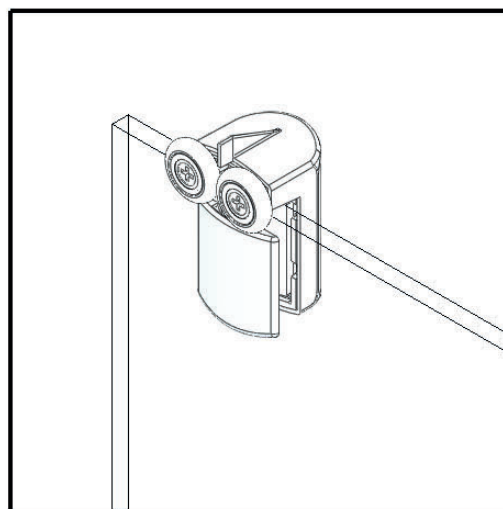
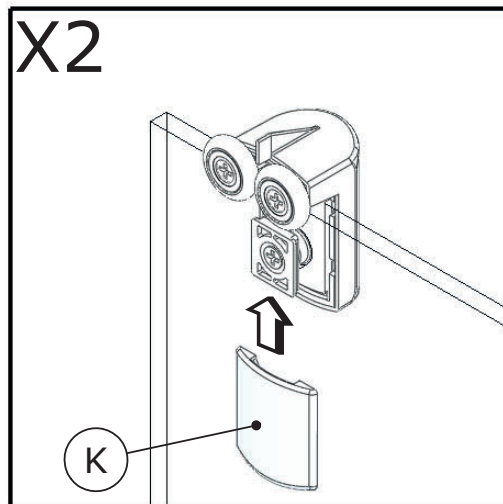
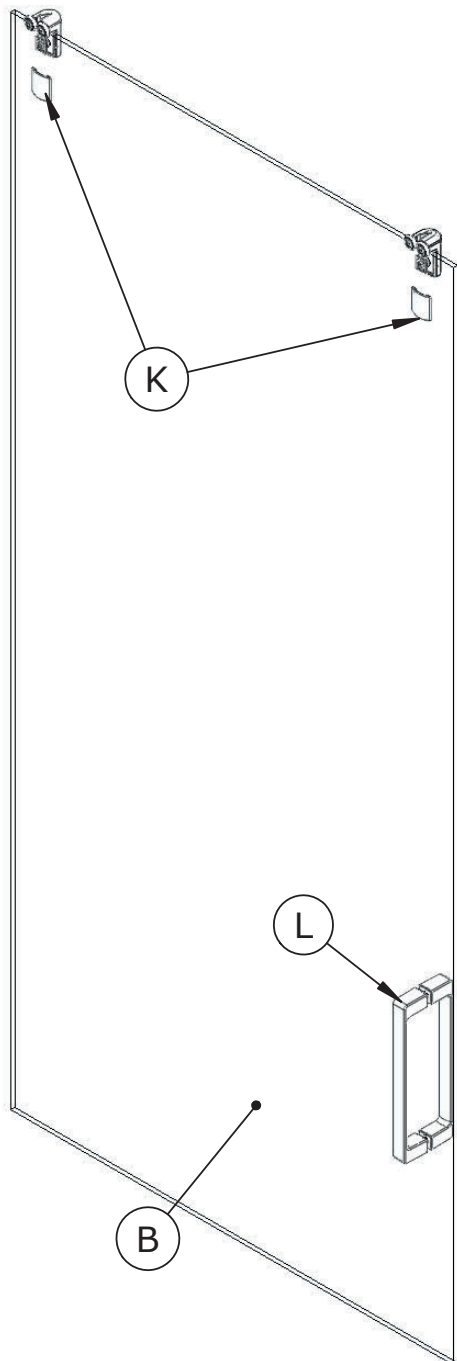

← Extérieur - Outside - Exterior - Exterior
- Esterno - Buienkant - Außen

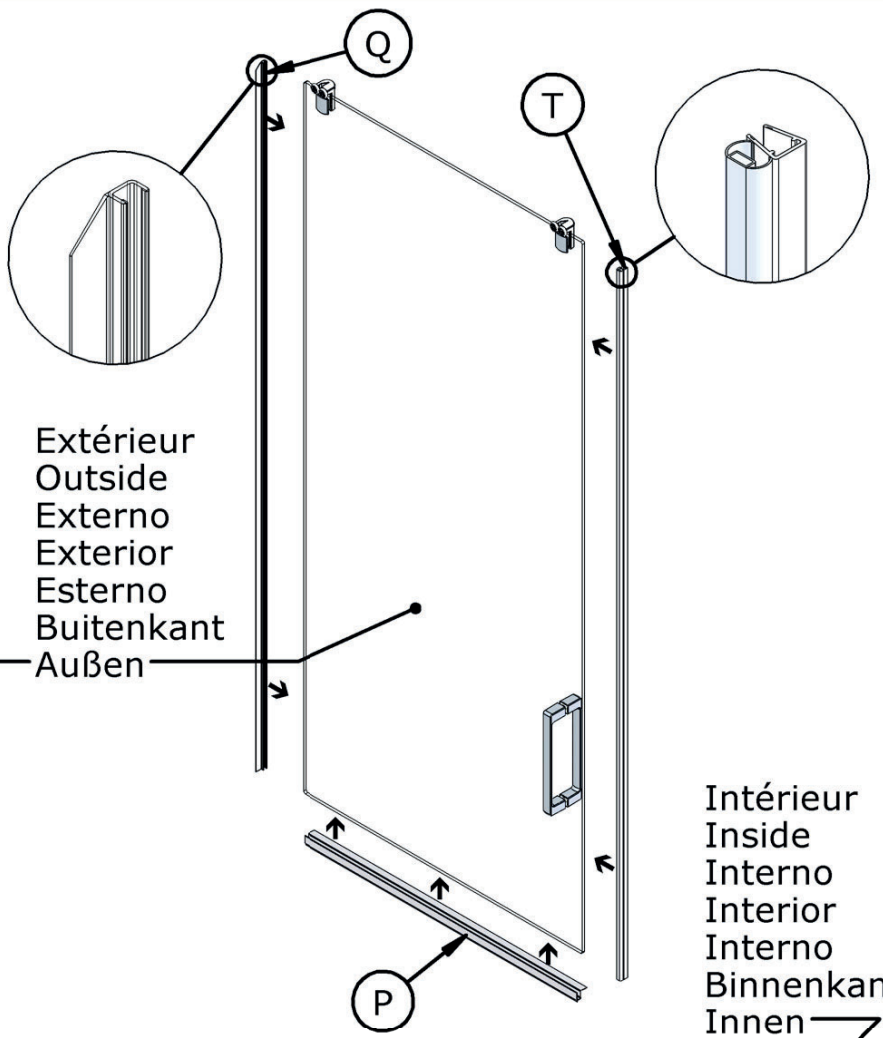
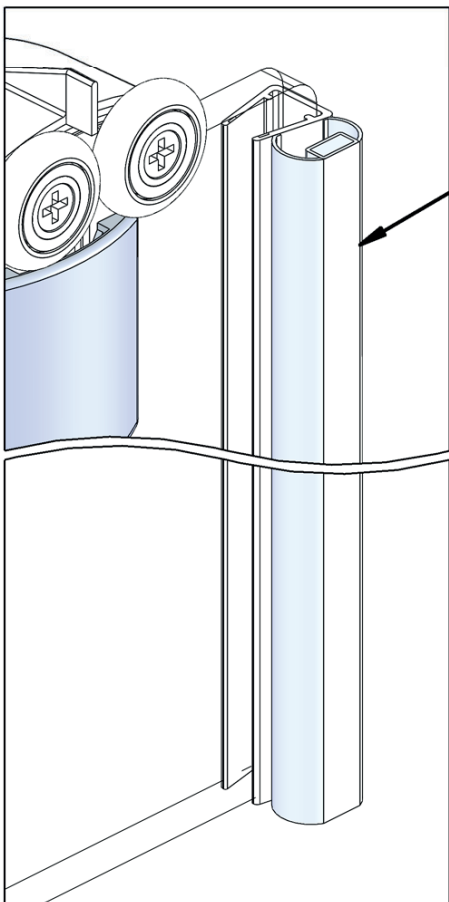
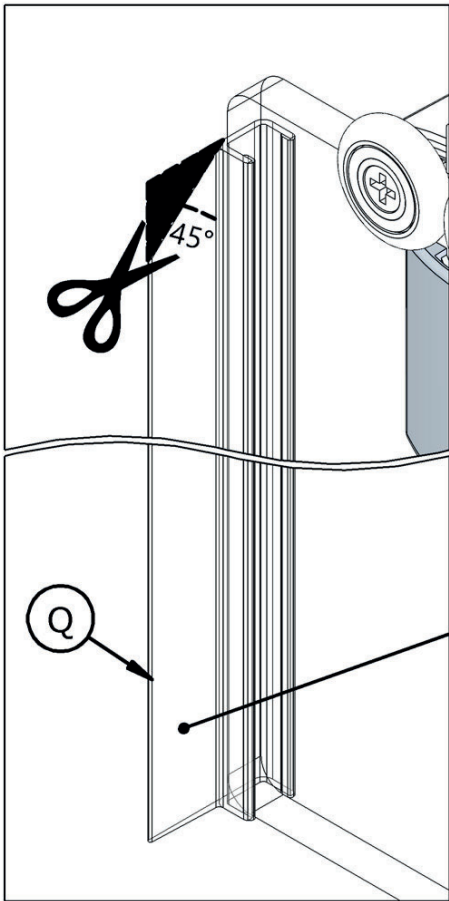

Extérieur
 Outside
 Externo
 Exterior
 Esterno
 Buitenkant
 Außen

Intérieur
 Inside
 Interno
 Interior
 Interno
 Binnenkant
 Innen

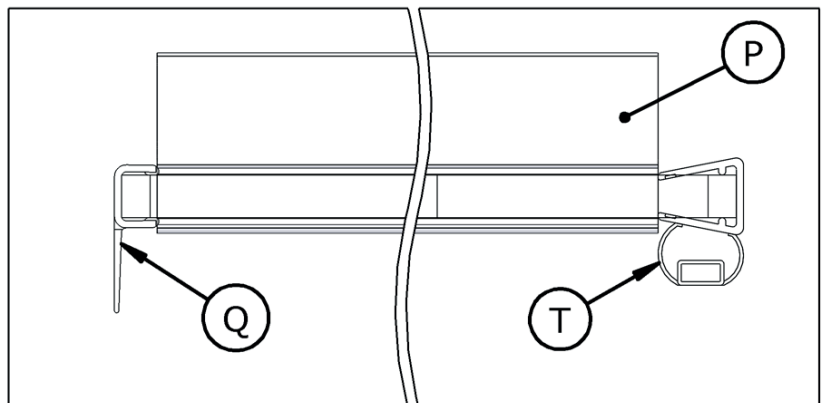
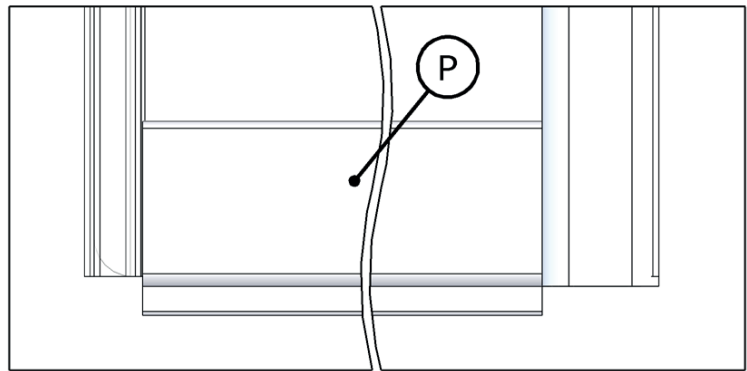

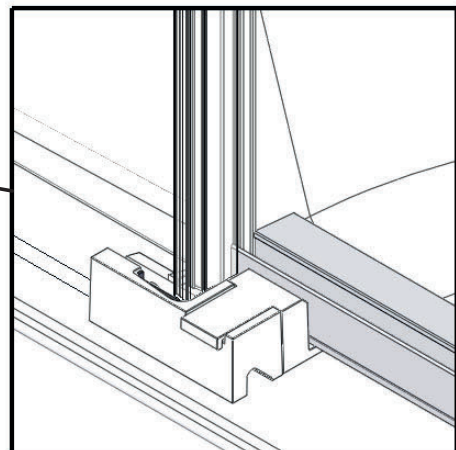
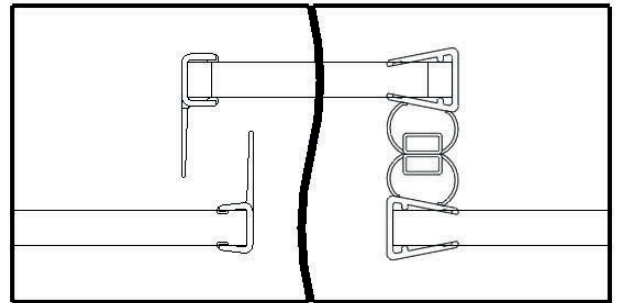
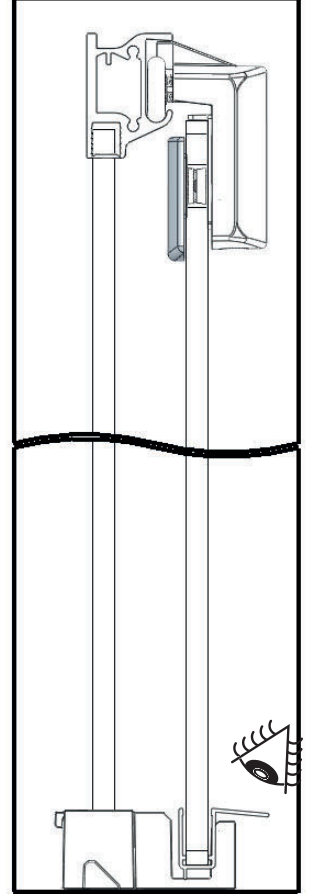
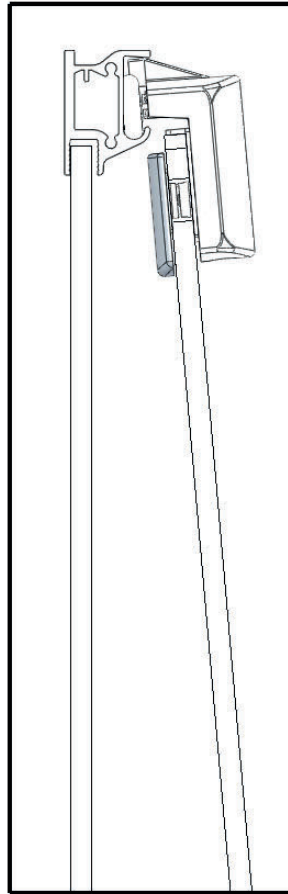
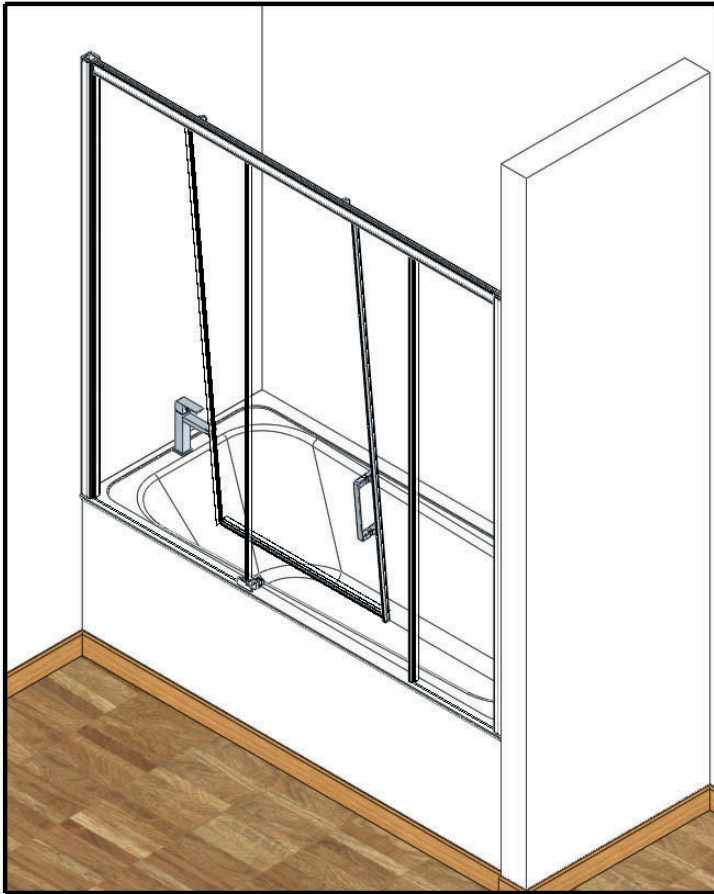



Réglage de la porte
Door adjustment
Ajuste de la puerta
Ajuste da porta
Regolazione porta
Afstellen van de deur
Einstellen der Tür

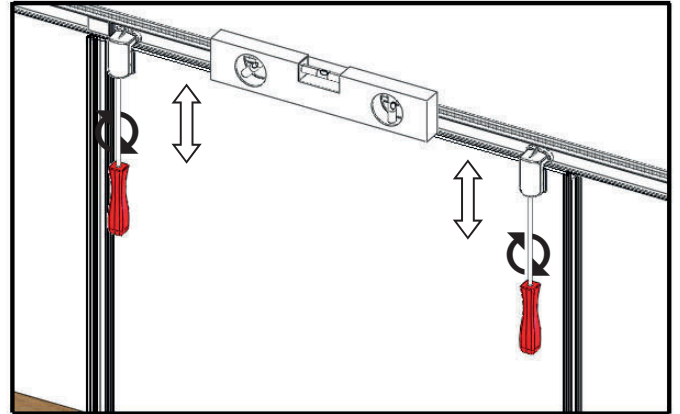

Intérieur - Inside
Interno - Interior
Ineterno - Binnenkant - Innen

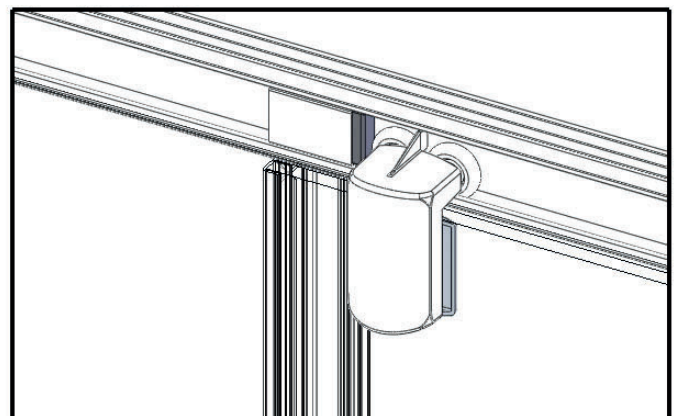
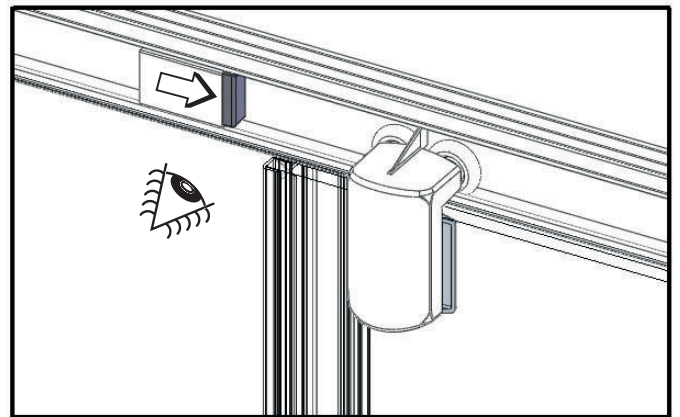

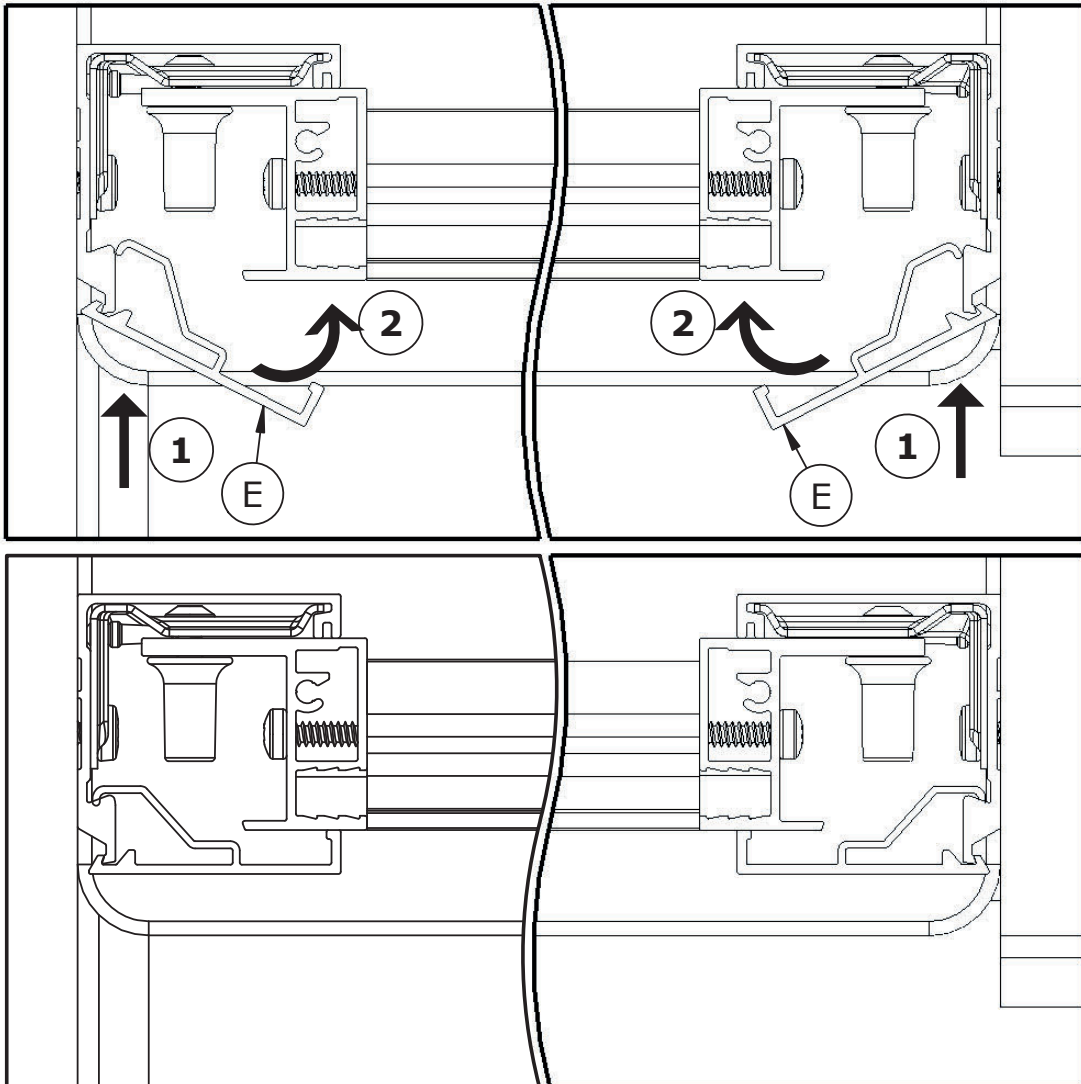
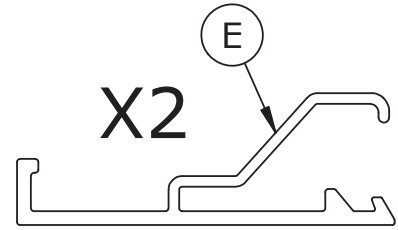
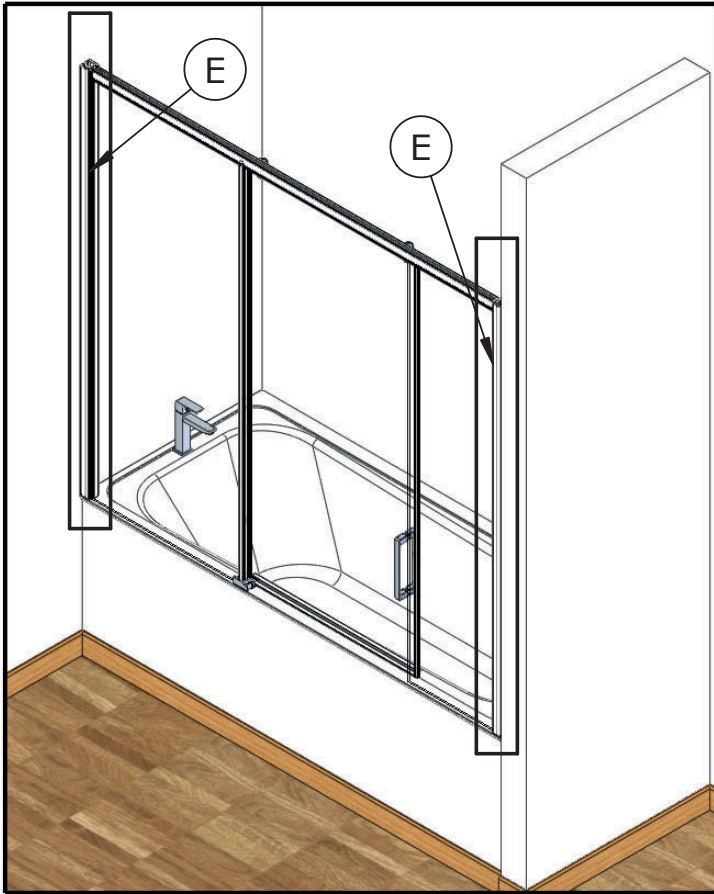

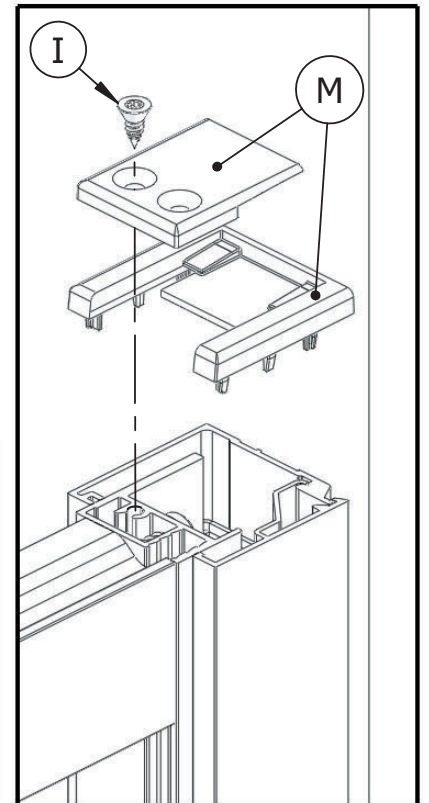
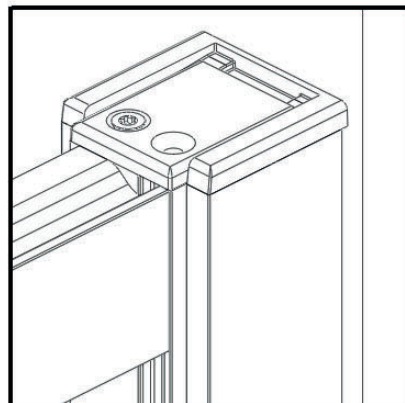
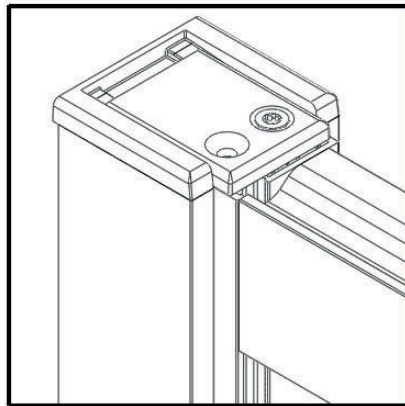
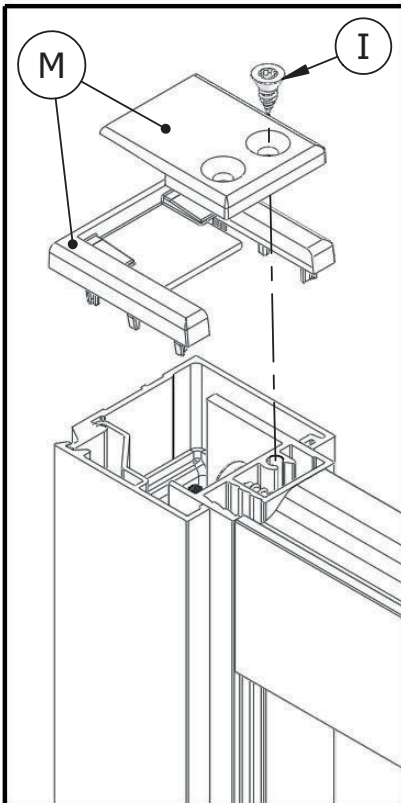
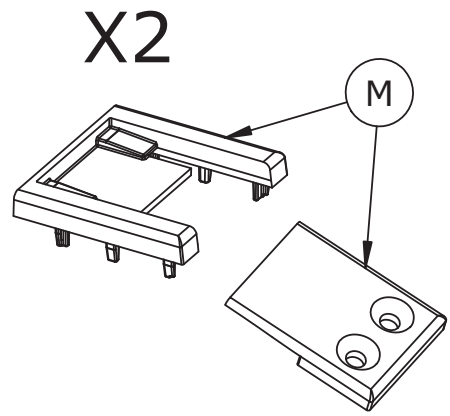
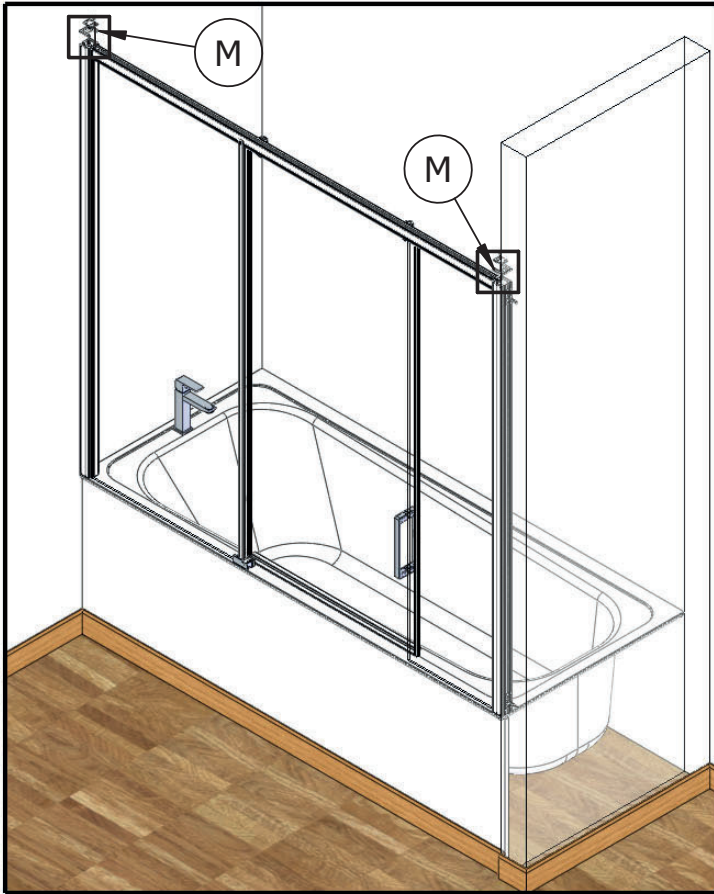

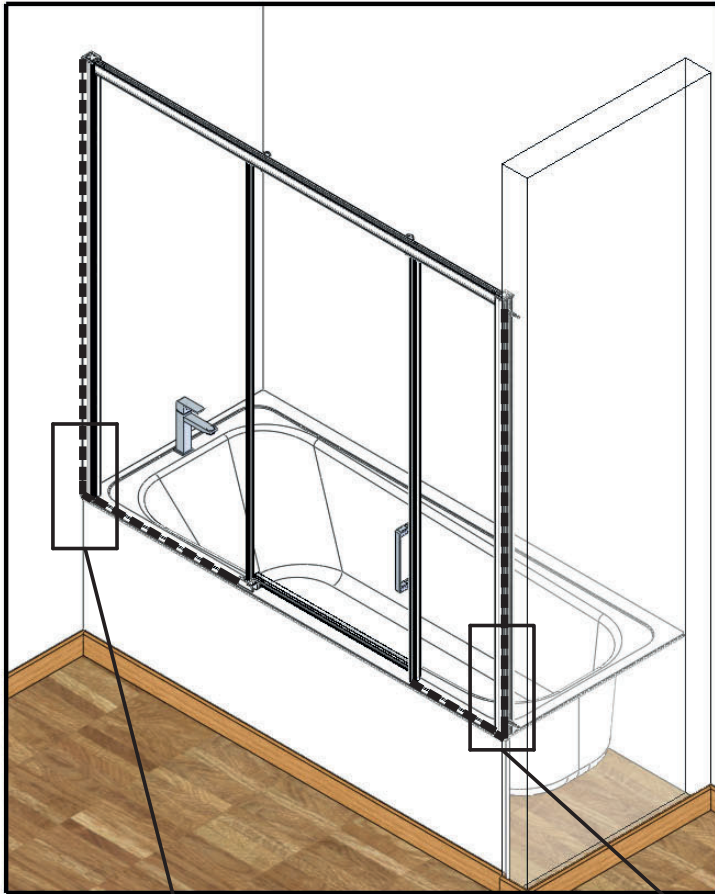

24h

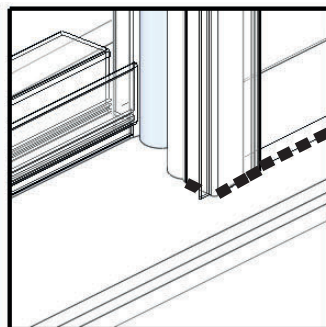
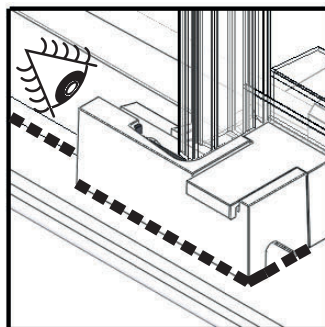
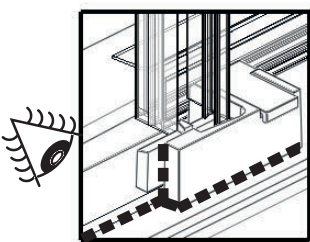
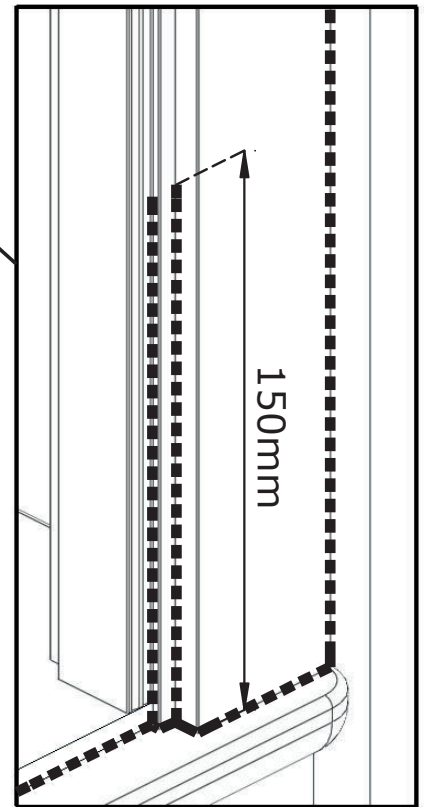
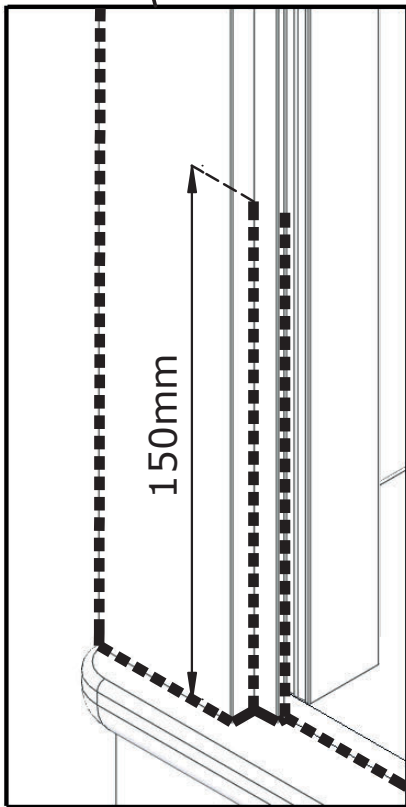
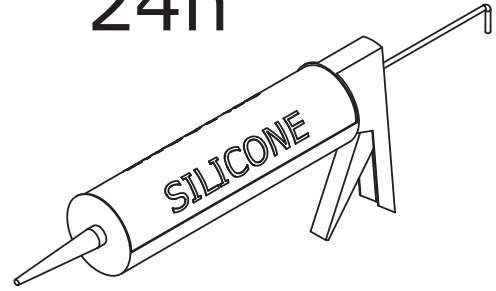

**NOTICE D'ENTRETIEN
MAINTENANCE INSTRUCTIONS
ISTRUZIONI DI MANUTENZIONE
INSTRUCCIONES DE MANTENIMIENTO
ONDERHOUDSINSTRUCTIE
WARTUNGSANLEITUNG**

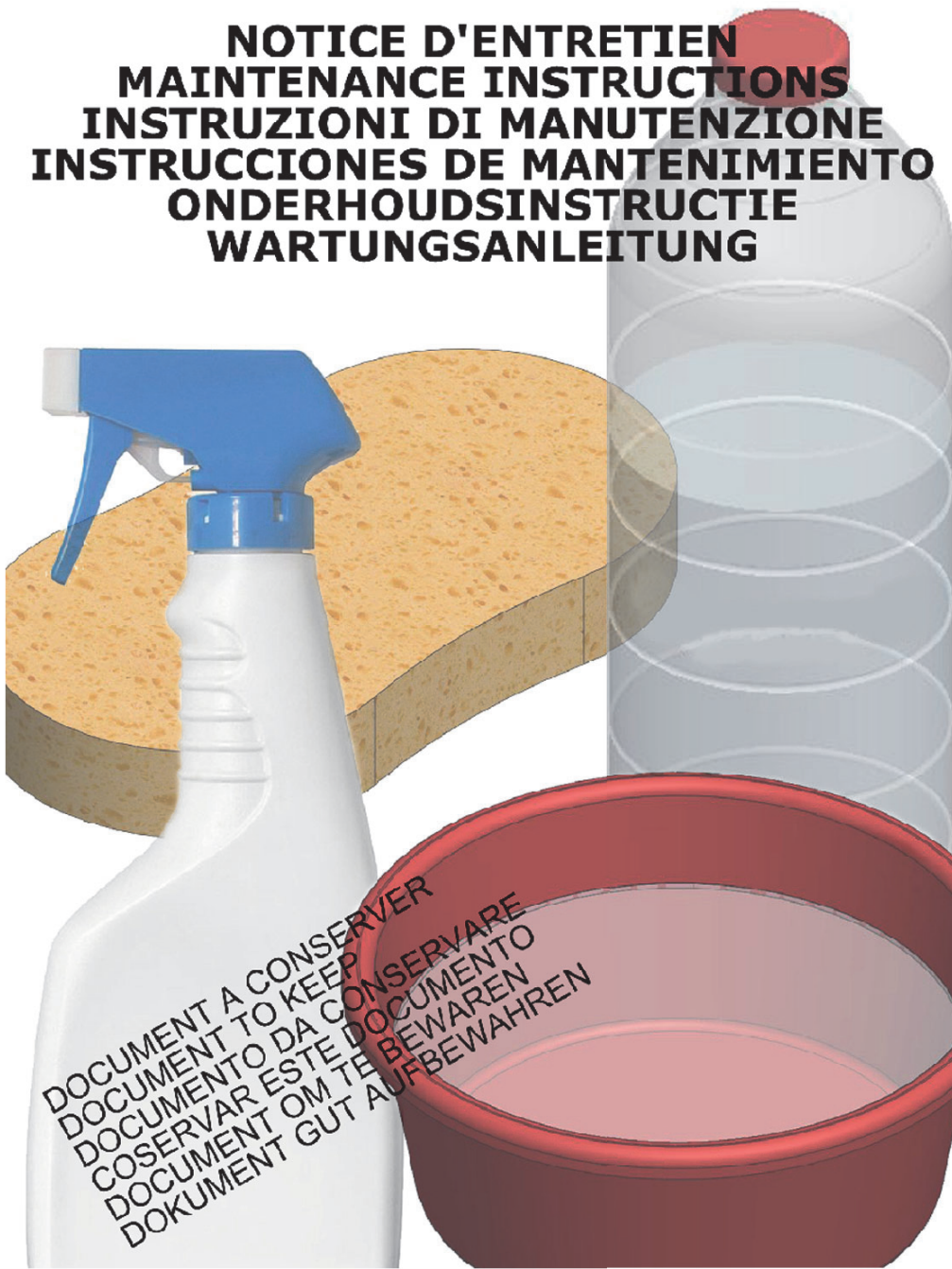

SCAN ME





SERVICE APRÈS-VENTE AFTER-SALES SERVICE

FRANCE

+33 (0)2 40 21 29 45

UK

+44 020 8842 0033

IRELAND

+353 04697 33102

DEUTSCHLAND

+49 (0) 6074 / 30928 0

ITALIA

+39 (0382) 6181

ÖSTEREICH

+43 1 710 60 70

SUISSE/SCHWEIZ

+41 (01) 748 17 44

ESPAÑA

+34 93 544 60 76

NEDERLAND

+31 475 487 100

BELGIQUE/BELGIË

+31 475 487 100

РОССИЯ

+7 495 258-29-51

PORTUGAL

+351 219 112 785



AQUAPRODUCTION, Site industriel,
F - 44680 Chaumes-en-Retz

22

EN 14428

Paroi de douche, fabriquée en verre de silicate
sodo-calcique de sécurité trempé thermiquement

Aptitude au nettoyage : réussite

Résistance à l'impact/propriétés de fragmentation : réussite

Durabilité : réussite