

● F Notice de montage ● GB Installation instructions
● I Istruzioni di montaggio
● NL Montage-instructies ● D Montageanleitung

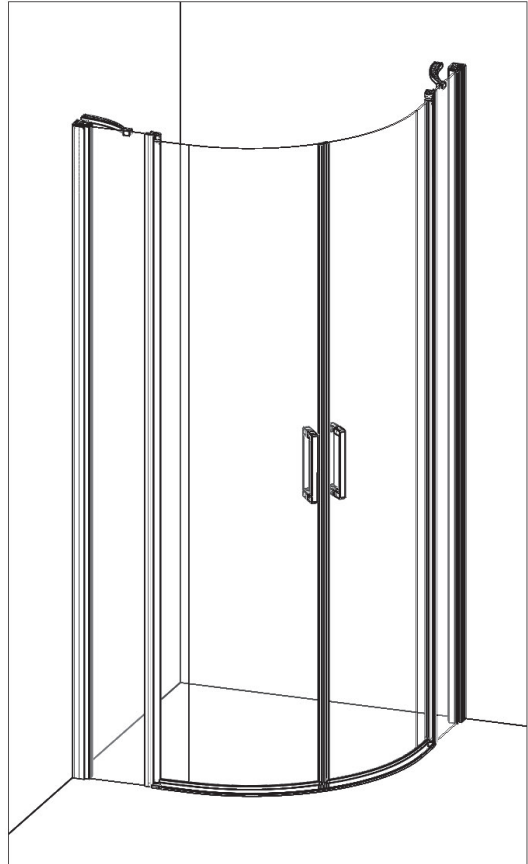







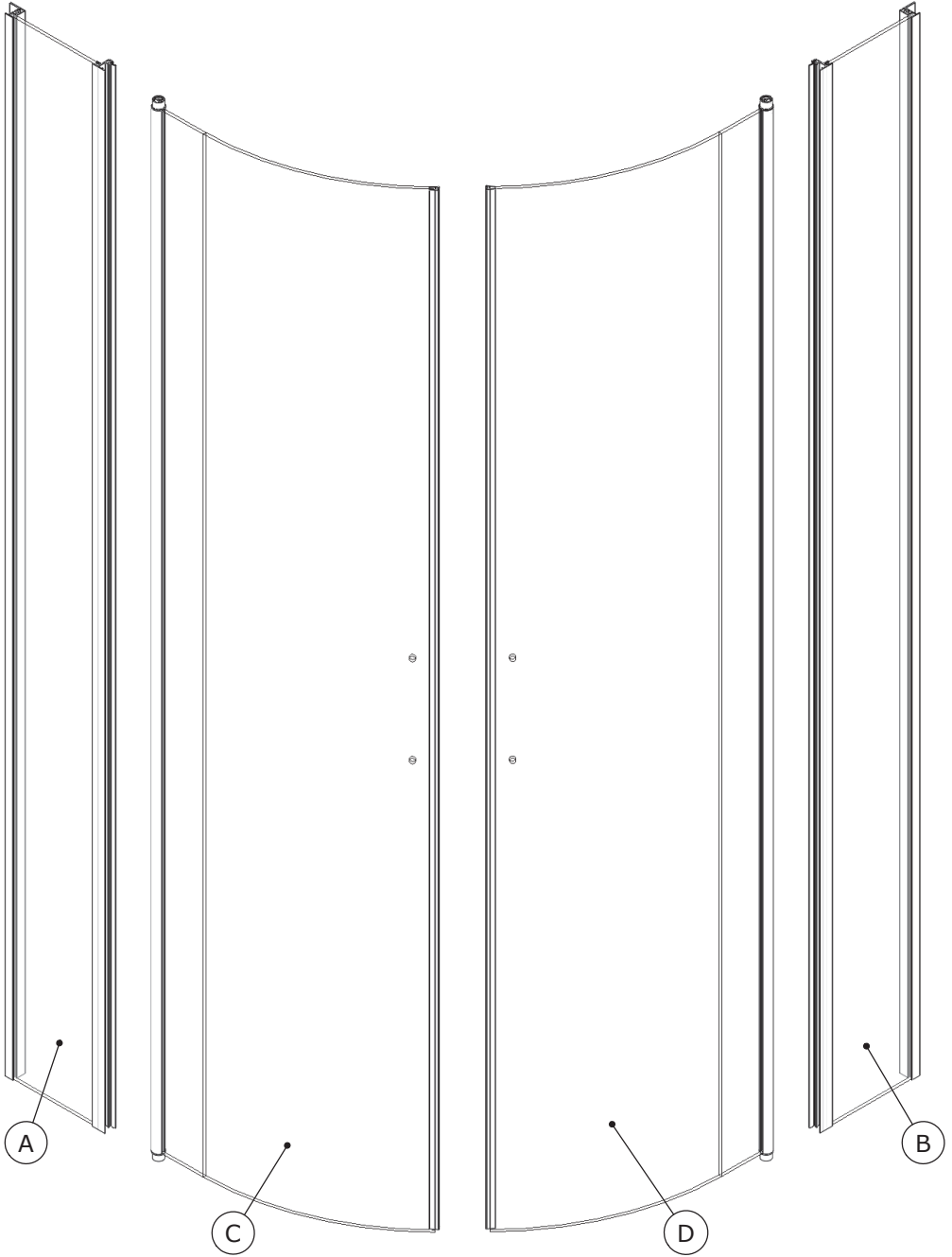

Notre service technique est à votre écoute aux numéros qui sont au dos de cette notice d'installation

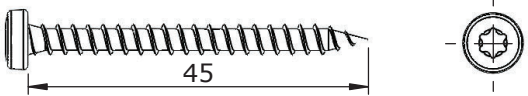
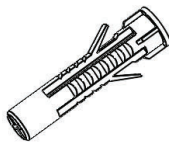
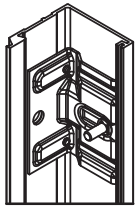
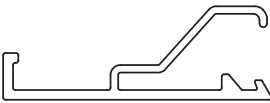
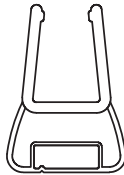

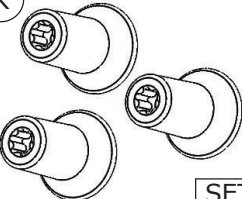
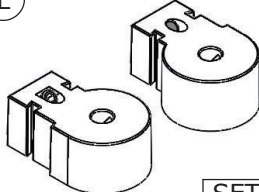
- F Attention aux étapes :
- GB Check installation steps :
- E Atención a los pasos :
- I Attenzione ai passi :
- NL Aandacht voor de stappen :
- D Achtung vor den Schritten :

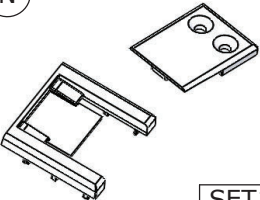
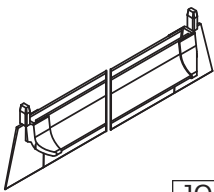
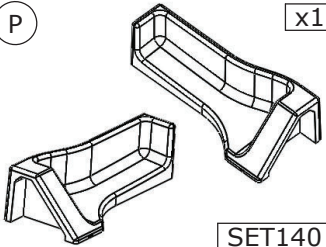
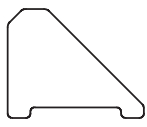
P. 5 - 13 - 31

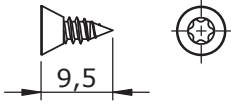
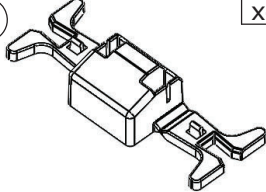

<p>E $\varnothing 3.5\text{mm}$ x6</p>  <p>45</p> <p>VIS231</p>	<p>F x6</p>  <p>CHE02</p>	
<p>G x2</p>  <p>6268</p>	<p>H x2</p>  <p>6270</p>	<p>I x2</p>  <p>Lg = 1952mm</p> <p>AI174</p>
<p>J x2</p>  <p>PPL1248</p>	<p>K x2</p>  <p>SET134</p>	<p>L x2</p>  <p>SET128</p>
<p>M x2</p>  <p>PGN49</p>	<p>N x2</p>  <p>SET137</p>	<p>O x1</p>  <p>JOI145</p>
<p>P x1</p>  <p>SET140</p>	<p>Q x1</p>  <p>6285</p>	<p>R x1</p>  <p>SUP129</p>
<p>$\varnothing 3.5\text{mm}$ x2</p>  <p>9,5</p> <p>VIS261</p>	<p>T x4</p>  <p>PPL1339</p>	<p>U x1</p>  <p>SUP130</p>

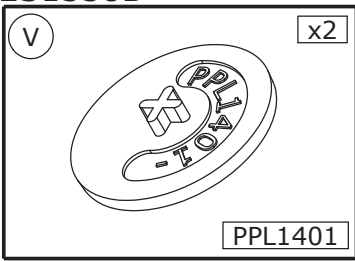

- Les quantités données sont les quantités utiles au montage. les sachets fournis contiennent des pièces supplémentaires.
- The quantities given are what are required for the installation. There may be some surplus in the package provide.
- Le quantità fornite sono le quantità necessarie al montaggio. I sacchetti forniti contengono pezzi supplementari.
- De aangegeven aantallen zijn vereist voor de montage. De verpakking bevat extra onderdelen.
- Die Mengenangaben beziehen sich auf die für die Montage nötigen Teile. Eventuell weitere beige packte Teile ignorieren.

Ⓕ Matériel nécessaire ⒼB Tools required

Ⓘ Materiale necessario ⓃL Benodigd gereedschap Ⓓ Benötigte Werkzeuge

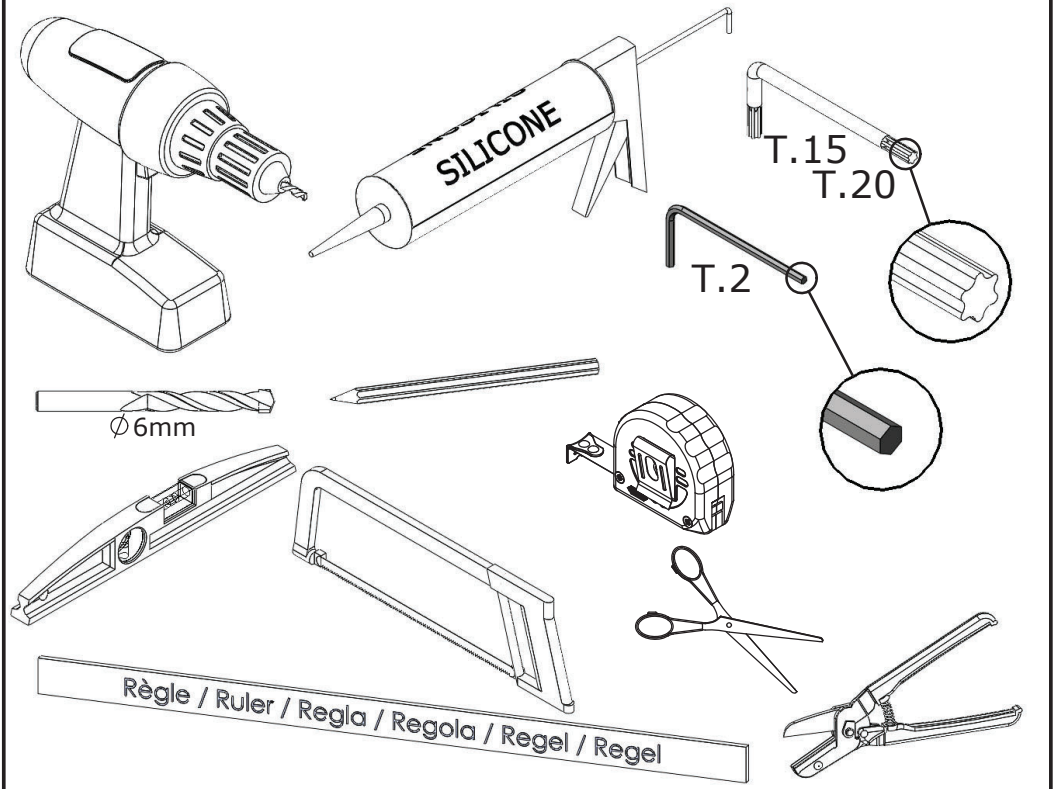

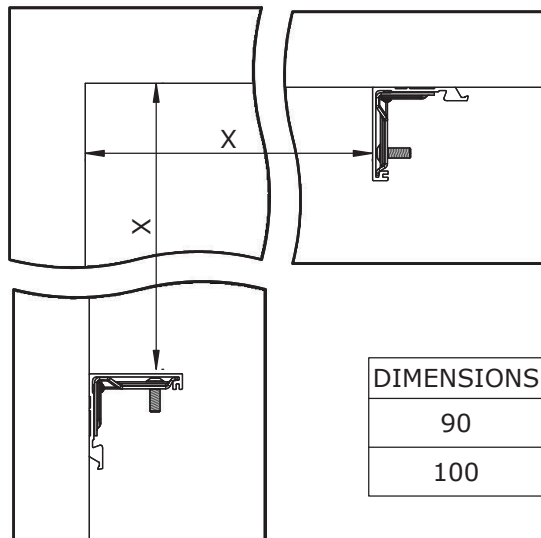
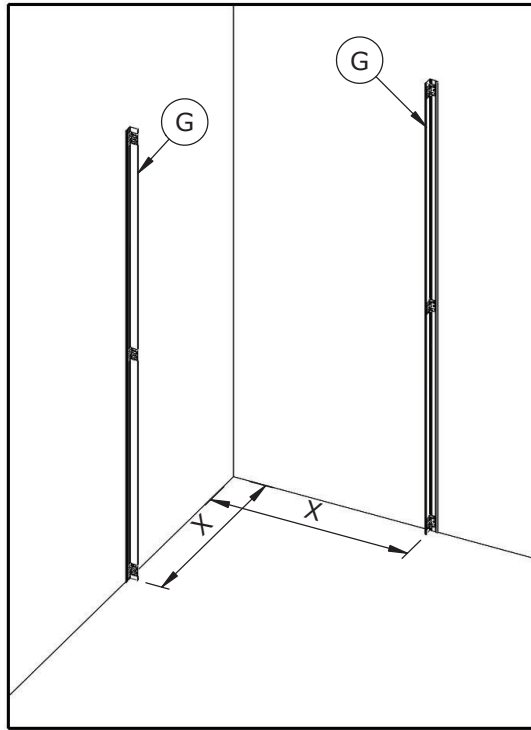

DIMENSIONS	X
90	830 - 845
100	930 - 945

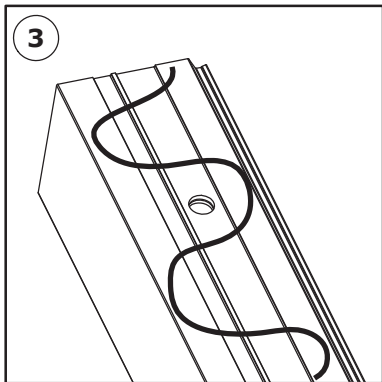
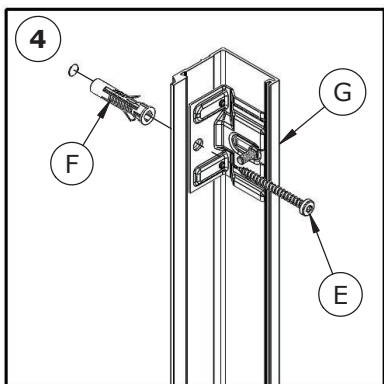
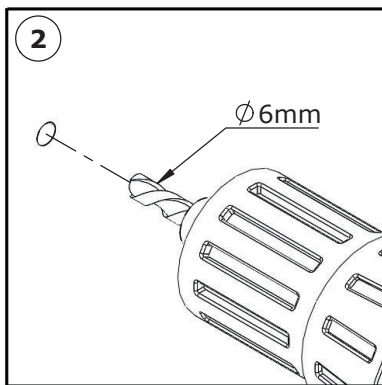
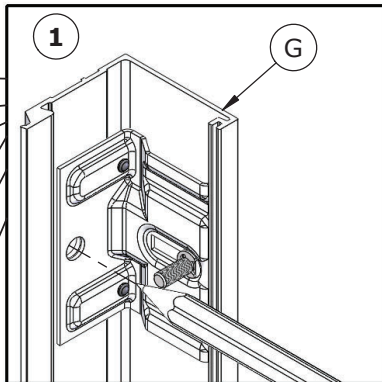
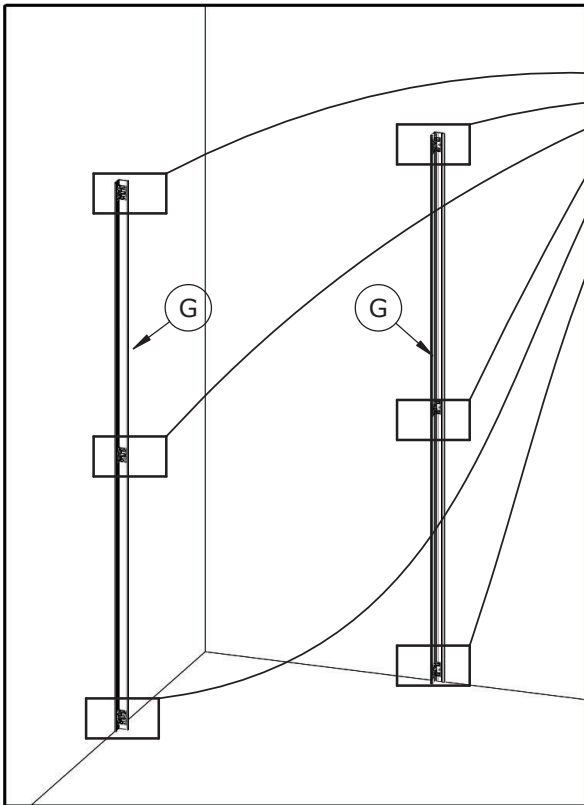

A

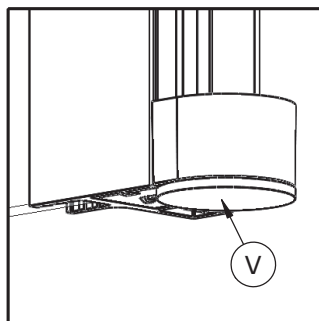
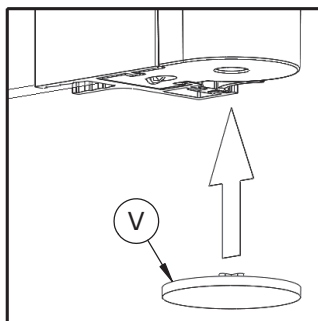
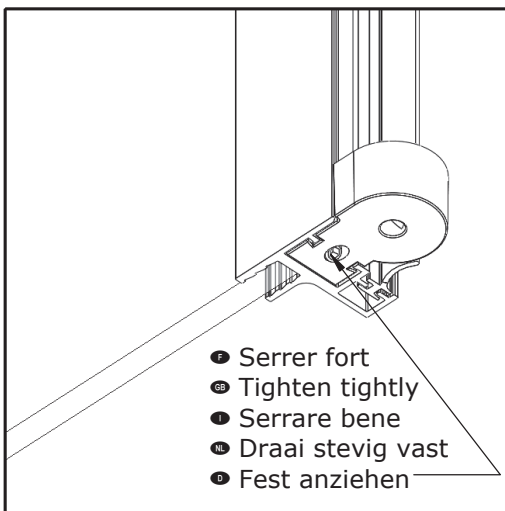
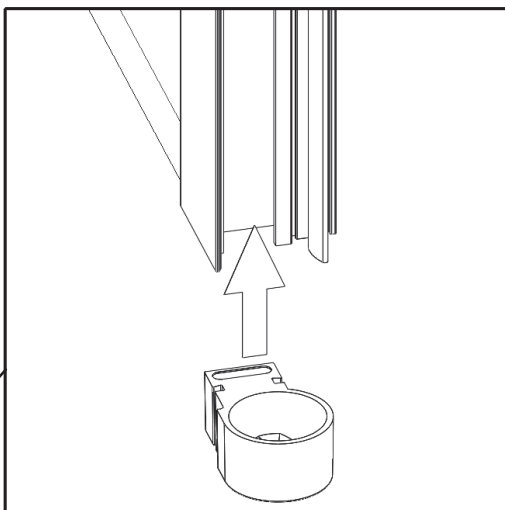
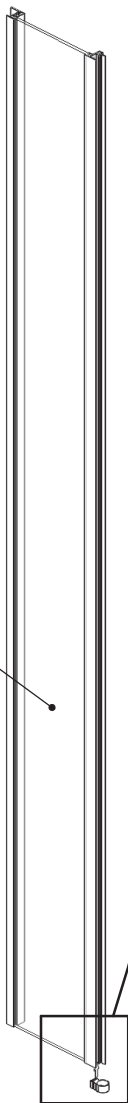

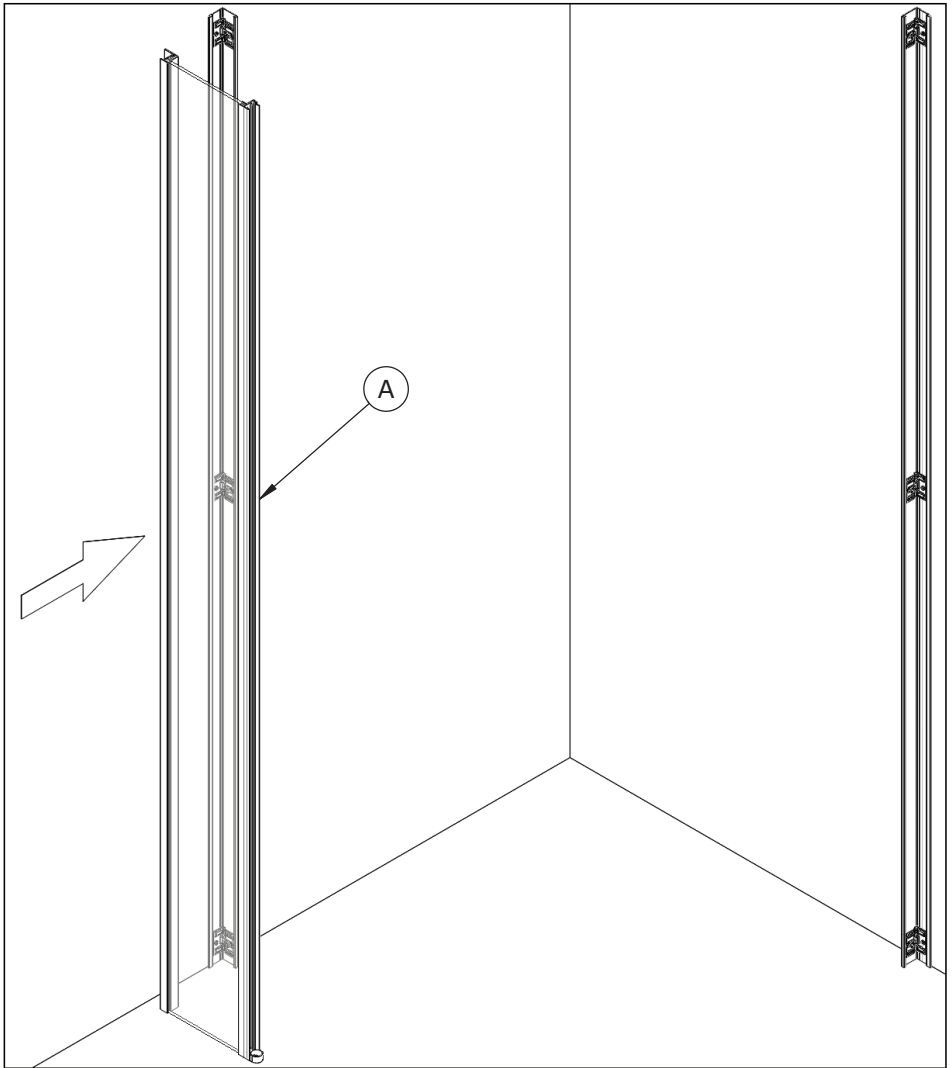

- Adjuster puis serrer ● Fit then tighten
- Regolare e poi serrare
- Stel af en draai vast ● Anpassen dann anziehen

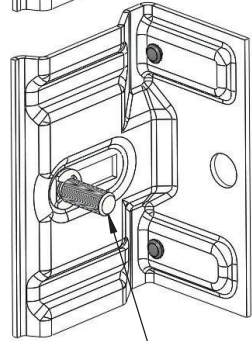
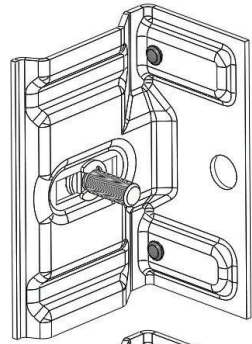

- Si nécessaire, desserrer, régler puis resserrer
- If necessary, loosen, adjust and retighten
- Se necesario, allentare, regolare e stringere
- Draai los, indien nodig, stel af en draai vervolgens weer vast
- Falls erforderlich, lösen, einstellen und wieder festziehen

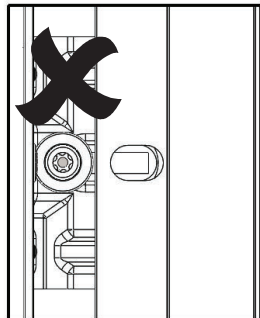
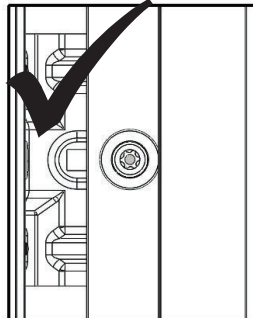
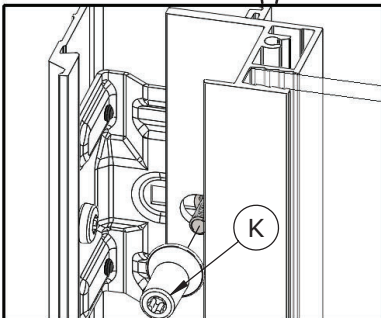
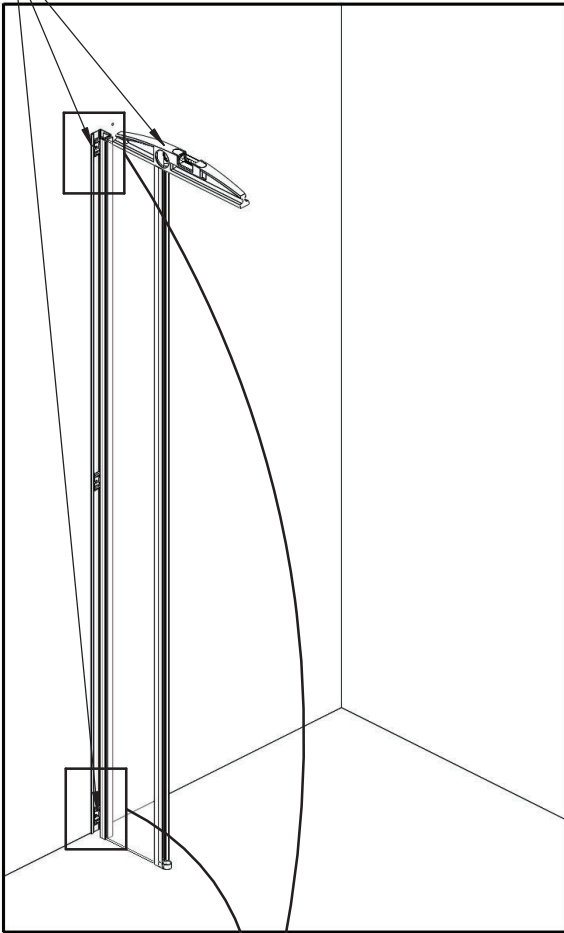

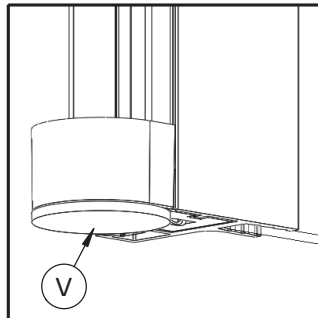
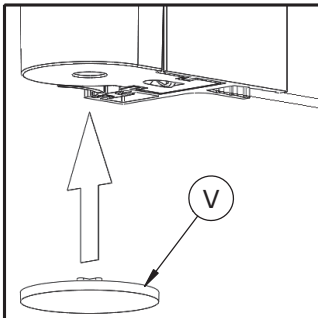
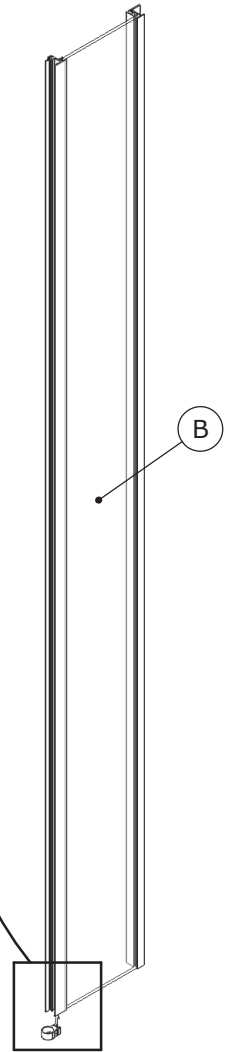
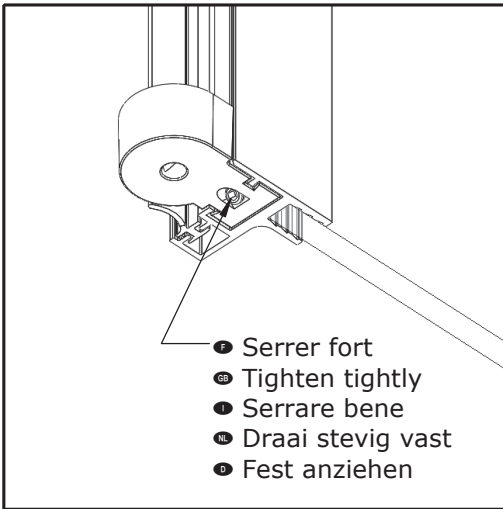
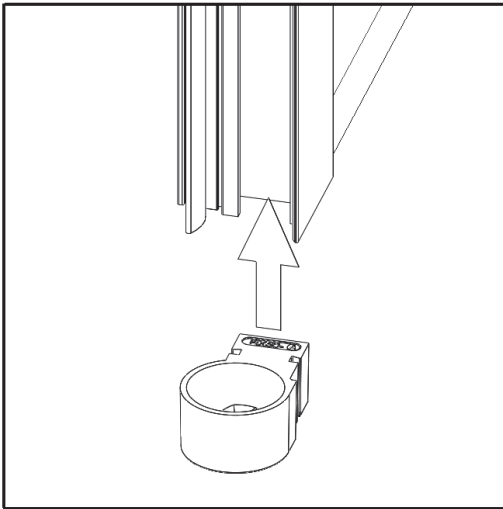

- Ajuster puis serrer ● Fit then tighten
- Regolare e poi serrare
- Stel af en draai vast ● Anpassen dann anziehen

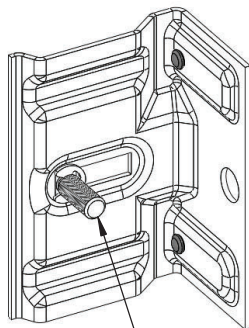
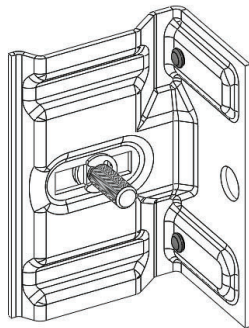

- Si nécessaire, desserrer, régler puis resserrer
- If necessary, loosen, adjust and retighten
- Se necesario, allentare, regular e stringere
- Draai los, indien nodig, stel af en draai vervolgens weer vast
- Falls erforderlich, lösen, einstellen und wieder festziehen

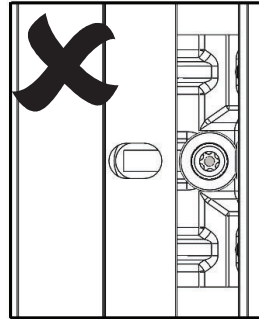
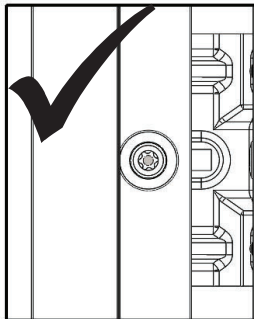
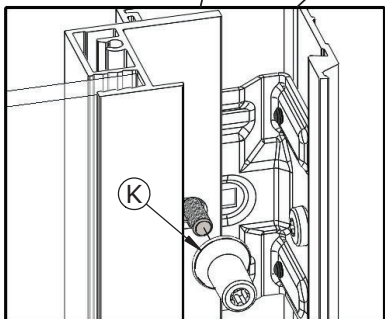
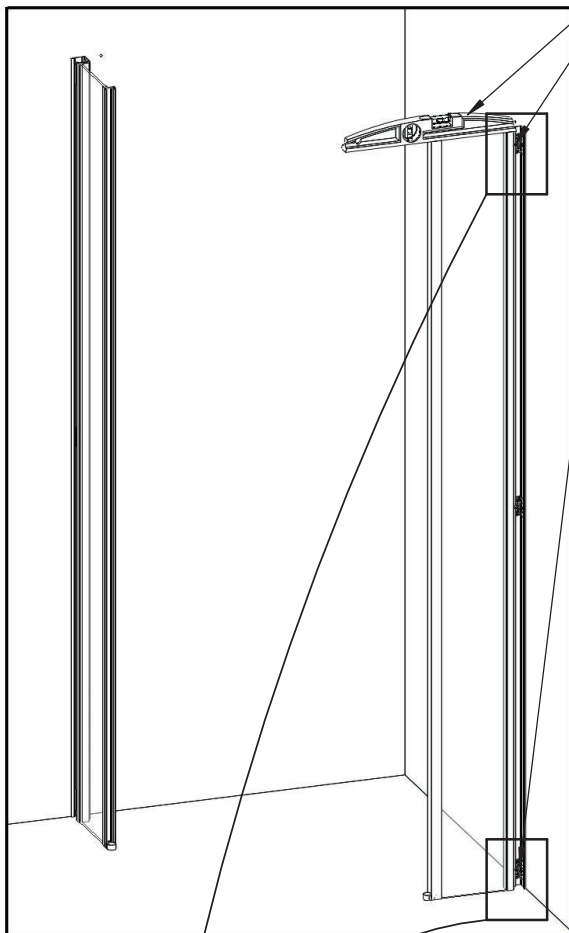

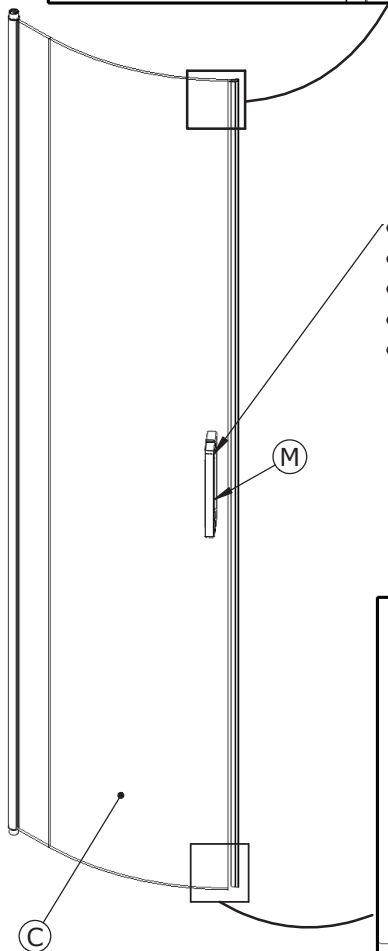
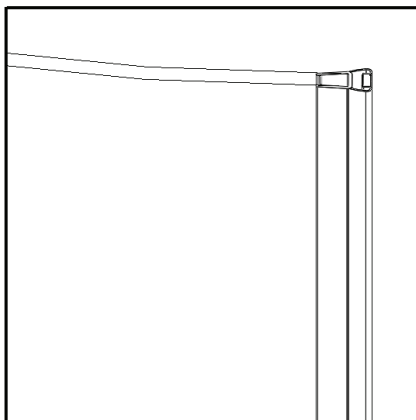
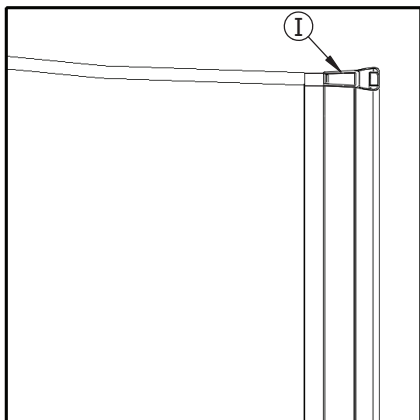

- F Voir notice concernée
- GB See installation instructions required
- I Vedere manuale appropriato
- NL Zie de bijbehorende montagehandleiding
- D Siehe betreffende Anleitung

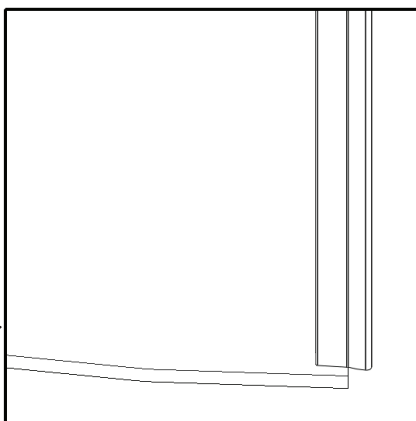

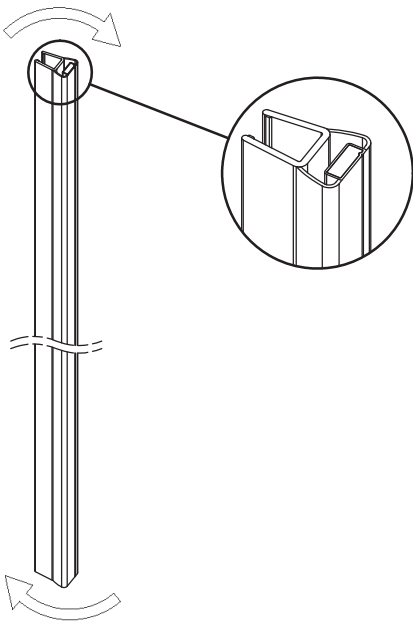
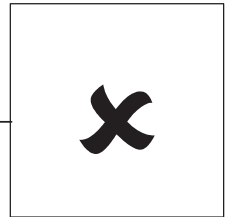
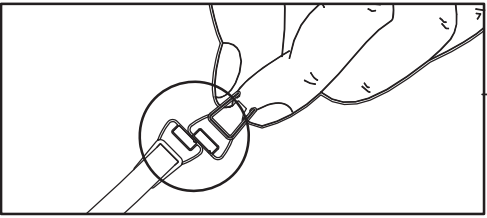
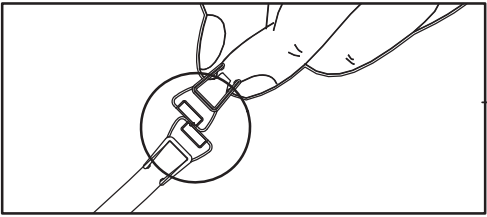
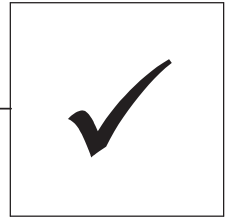
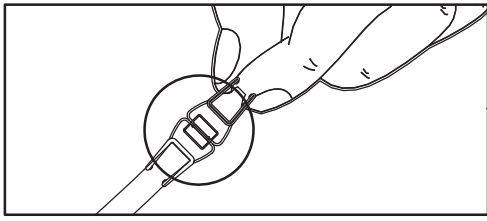

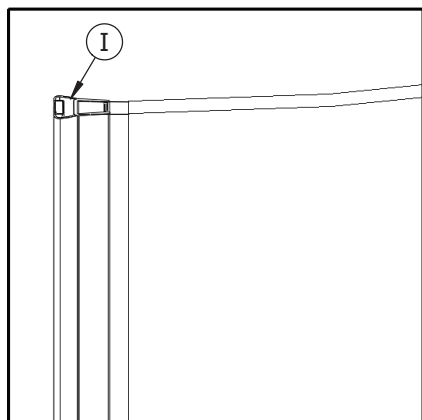
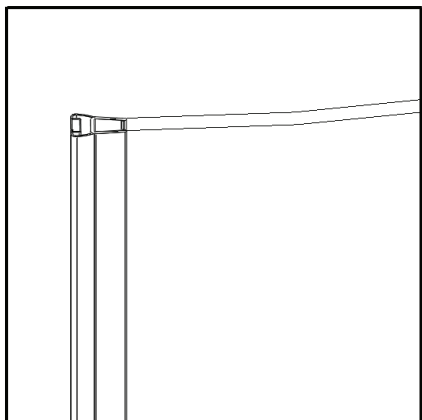

- Voir notice concernée
- See installation instructions required
- Vedere manuale appropriato
- Zie de bijbehorende montagehandleiding
- Siehe betreffende Anleitung

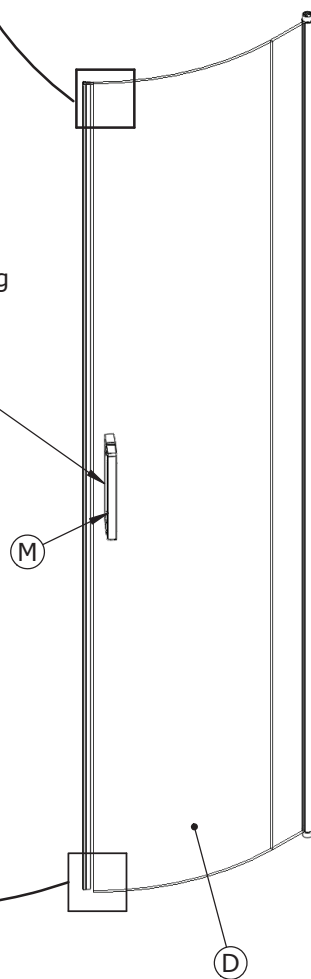
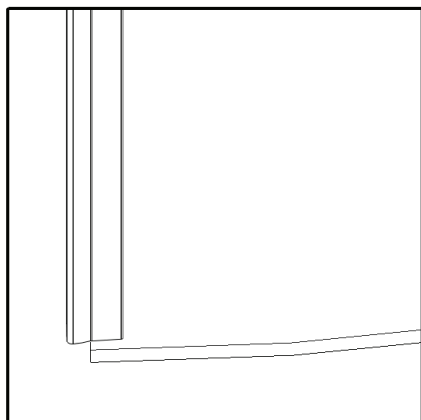

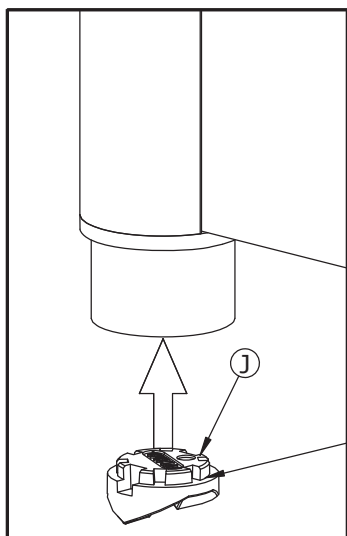
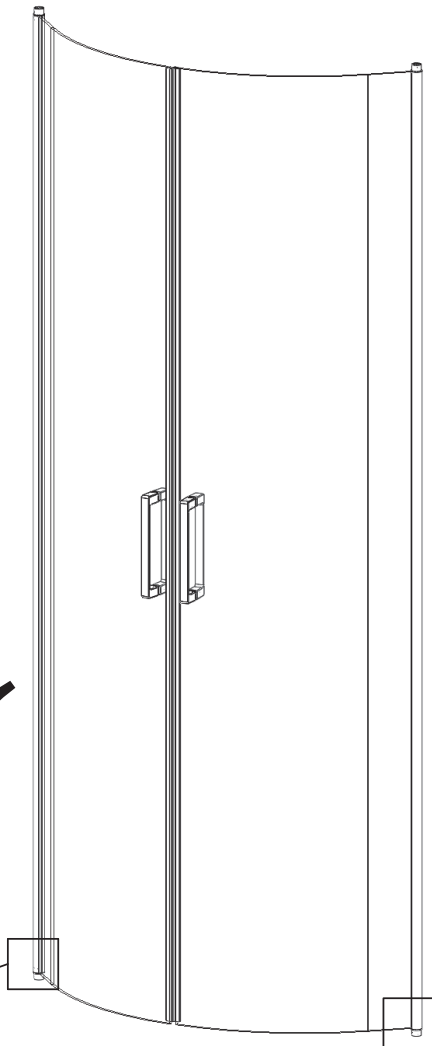
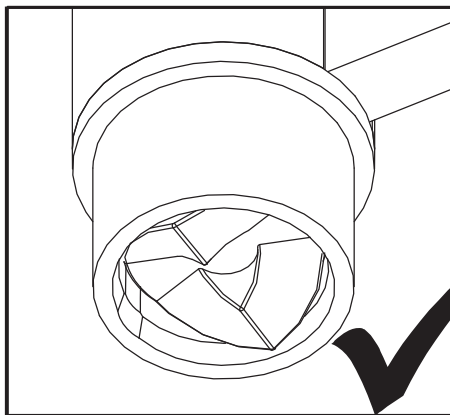
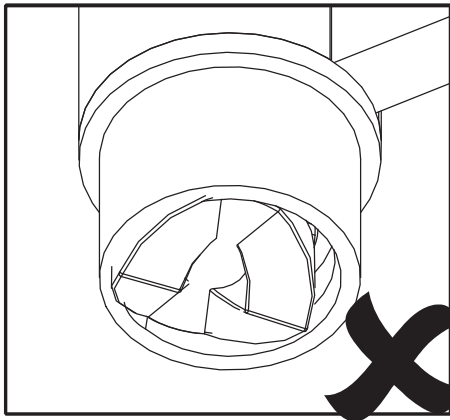

X2



- Mettre en partie basse
- Put in the lower part
- Mettere nella parte inferiore
- Plaats in het onderste deel
- Setzen Sie in den unteren Teil.

- Réglages des portes ● Adjusting the doors ● regolazione porte
- Deuren afstellen ● Ausrichten und Einstellen der Tür

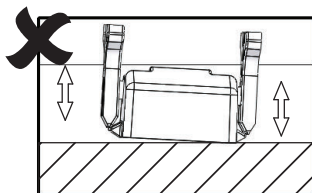
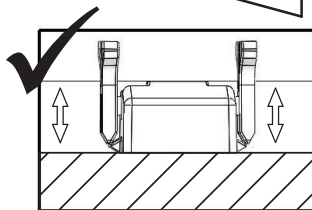
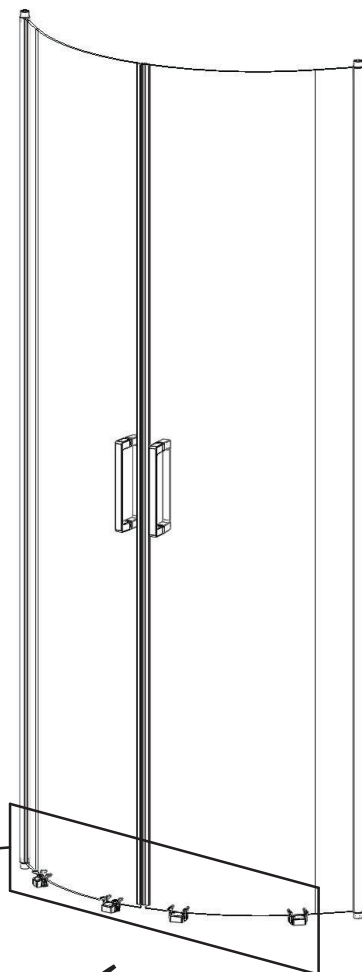
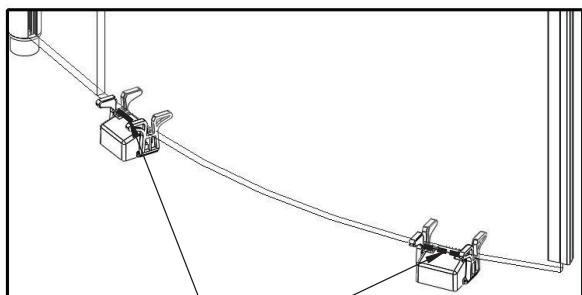
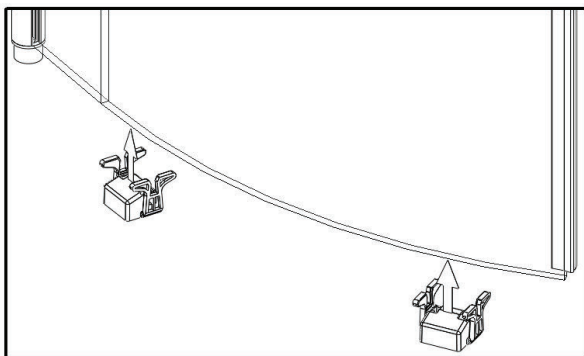
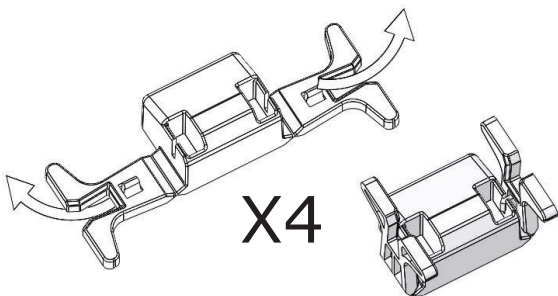

- Mettre en contact
- Put in contact
- Mettere in contatto
- Mensen in contact te brengen
- Kontakte knüpfen



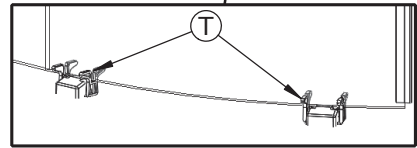
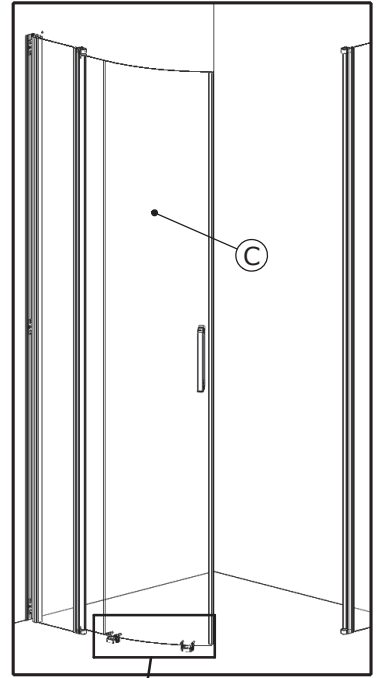
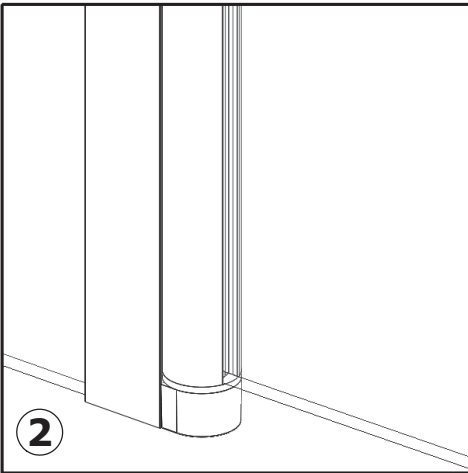
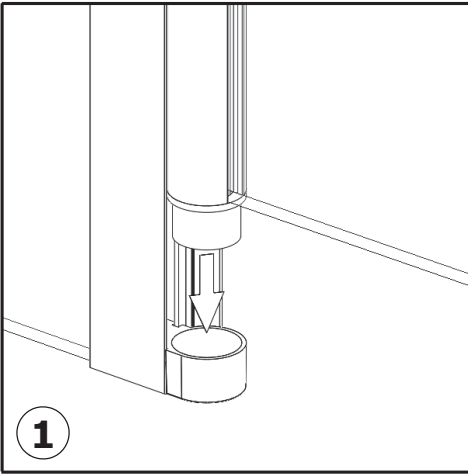

- Affleurant
- Align
- A filo
- Zijkanten niet laten uitsteken
- Bündig auszurichtende oberseiten

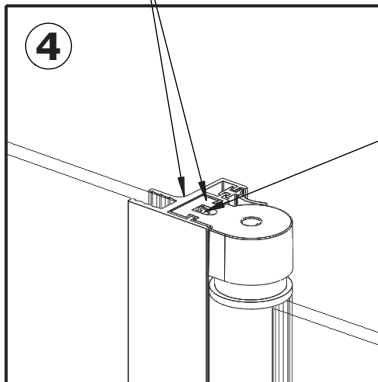
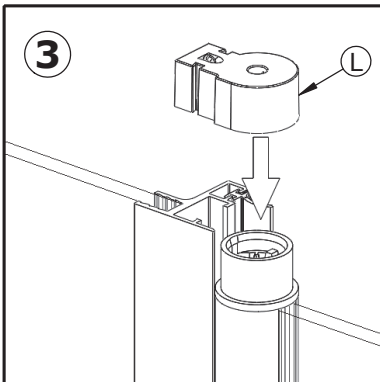

- Serrer fort
- Tighten tightly
- Serrare bene
- Draai stevig vast
- Fest anziehen

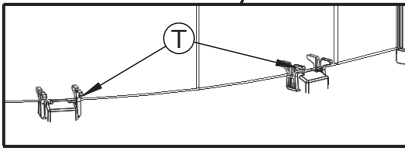
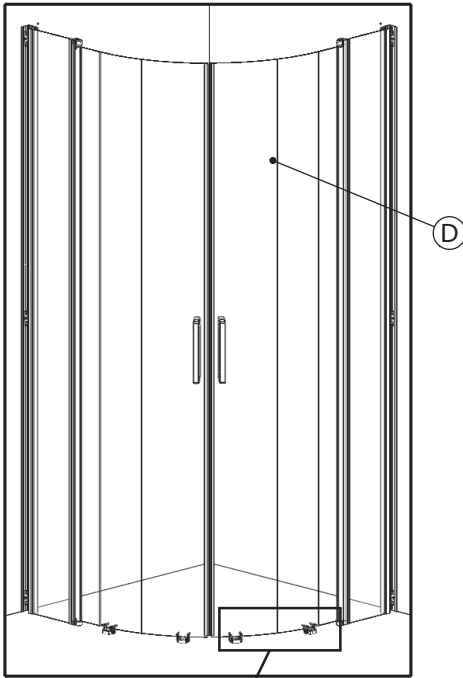

- Affleurant
- Align
- A filo
- Zijkanten niet laten uitsteken
- Bündig auszurichtende oberseiten

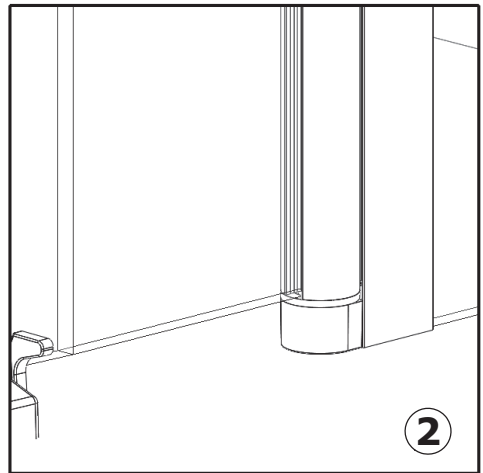
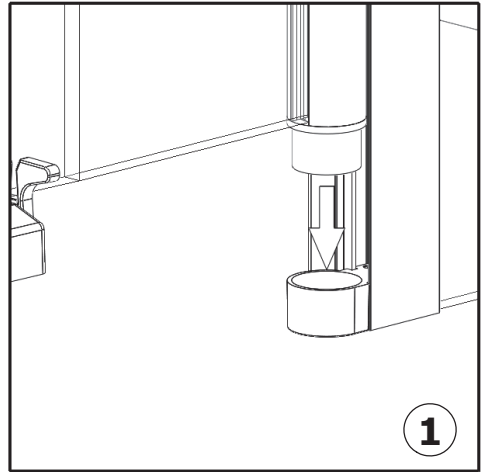

- Serrer fort
- Tighten tightly
- Serrare bene
- Draai stevig vast
- Fest anziehen

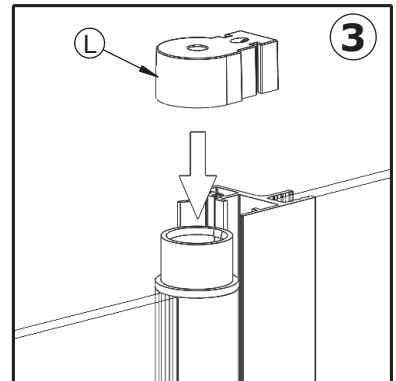
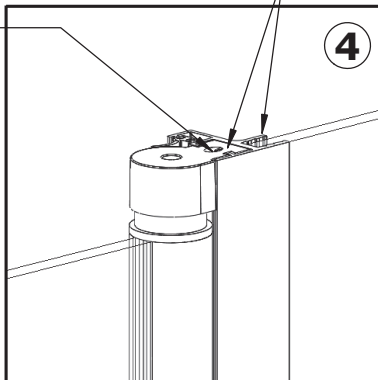

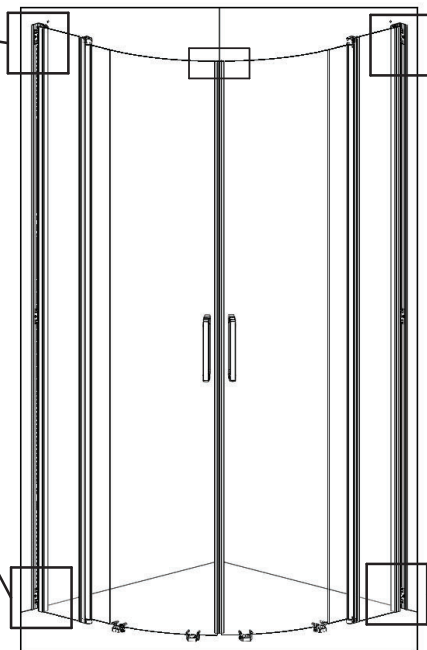
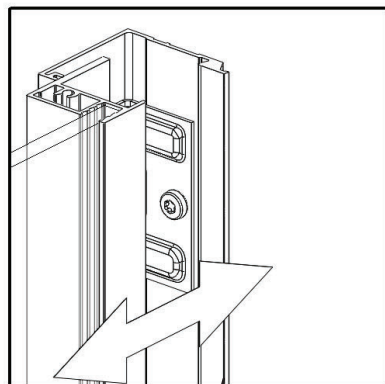
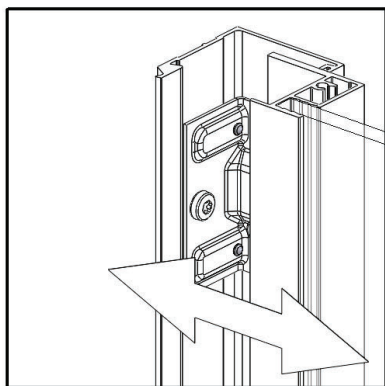
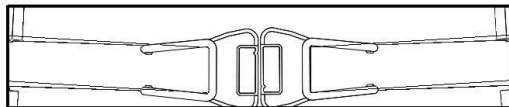

- F Ajuster si necessaire, puis resserrer
- GB Adjust if necessary, then tighten again
- I regolare se necessario poi serrare
- NL Stel af indien nodig, en draai dan vast
- D Gegebenenfalls nachjustieren, dann nachziehen

R/U

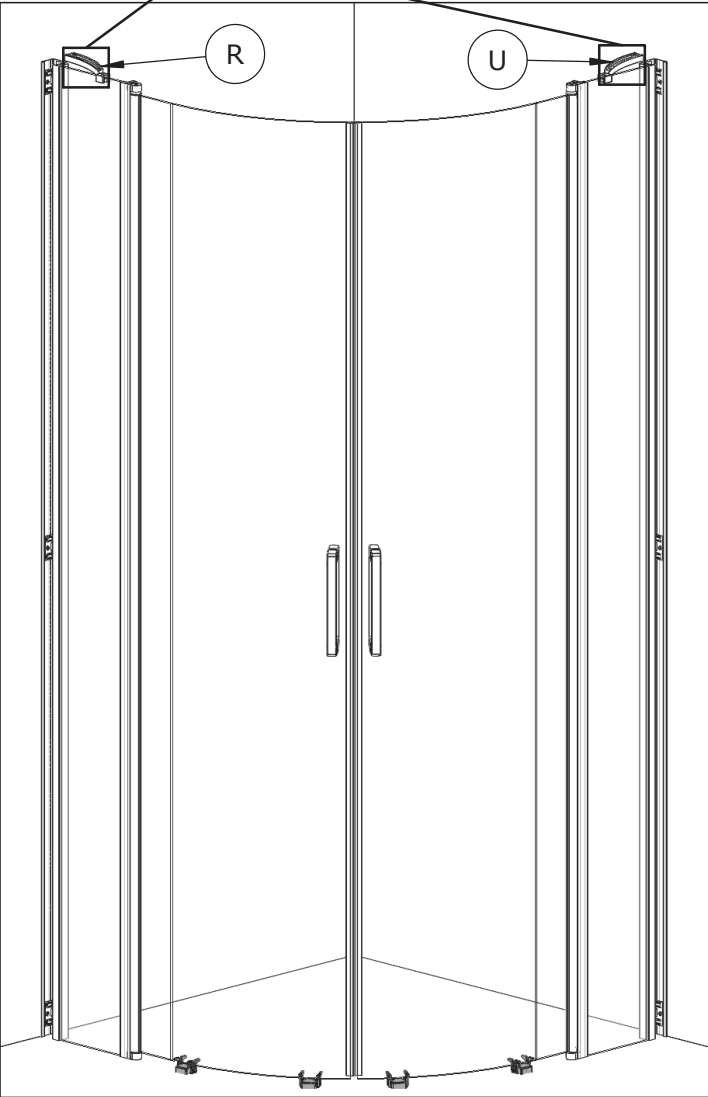
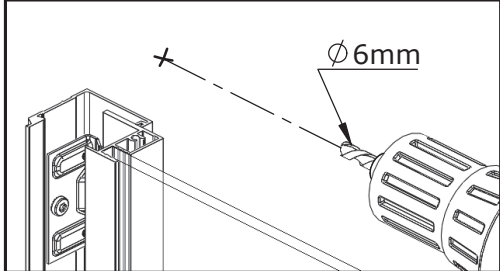
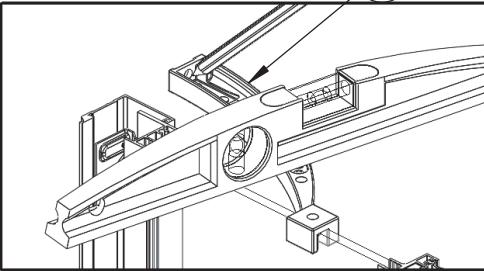

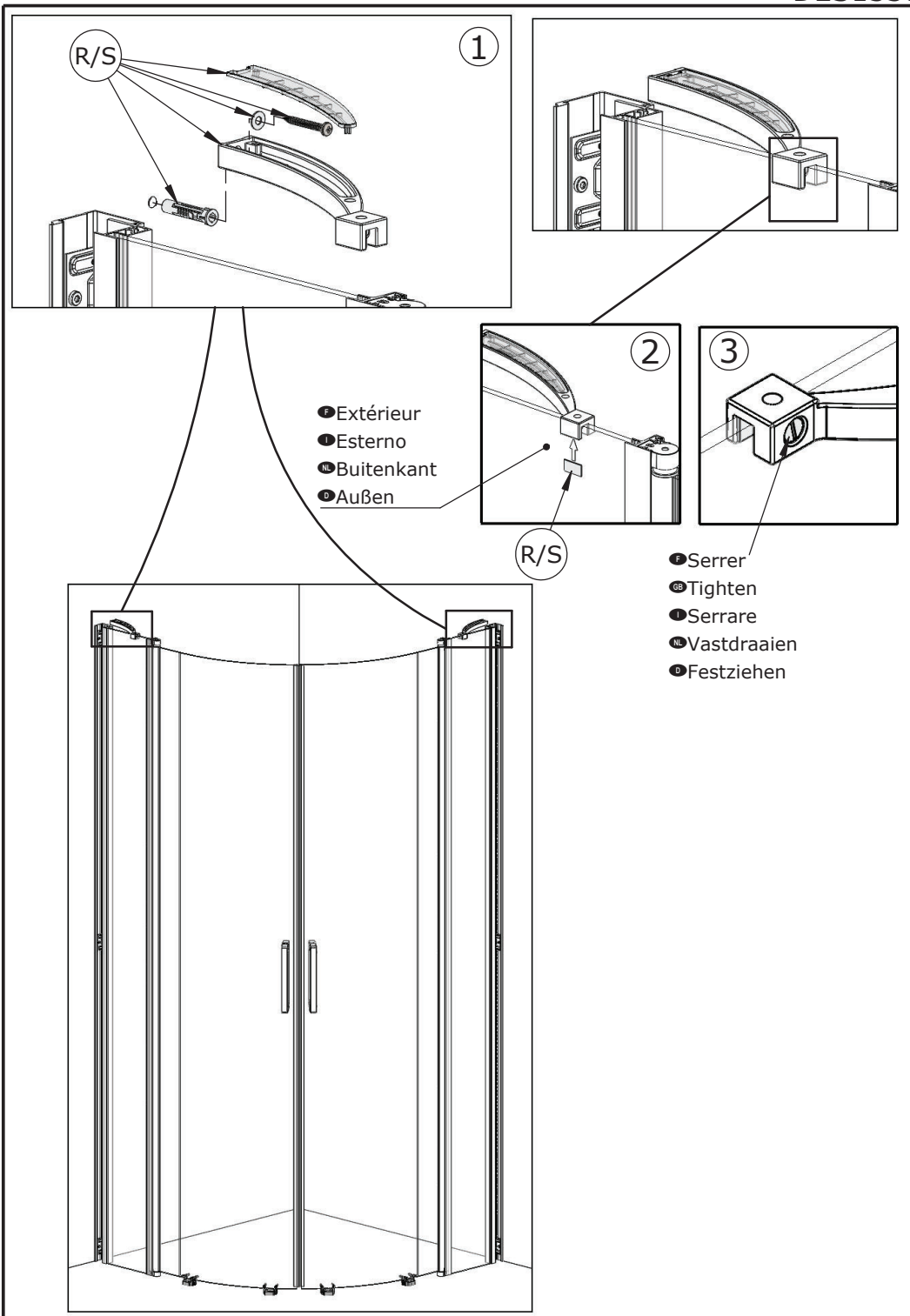

- F Ajuster puis serrer
- GB Fit then tighten
- I Regolare e poi serrare
- NL Stel af en draai vast
- D Anpassen dann anziehen

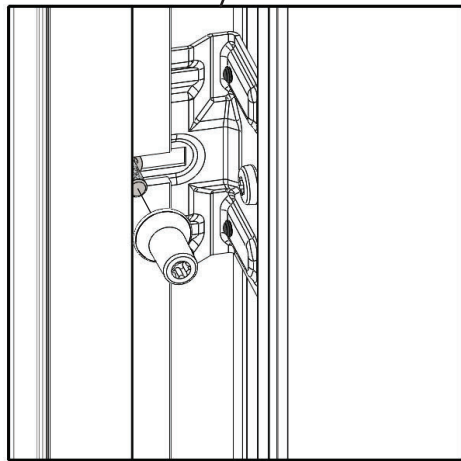
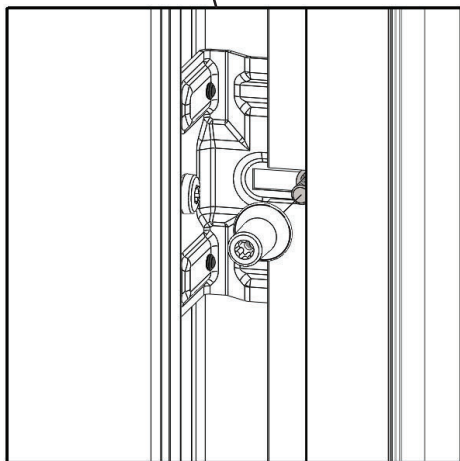
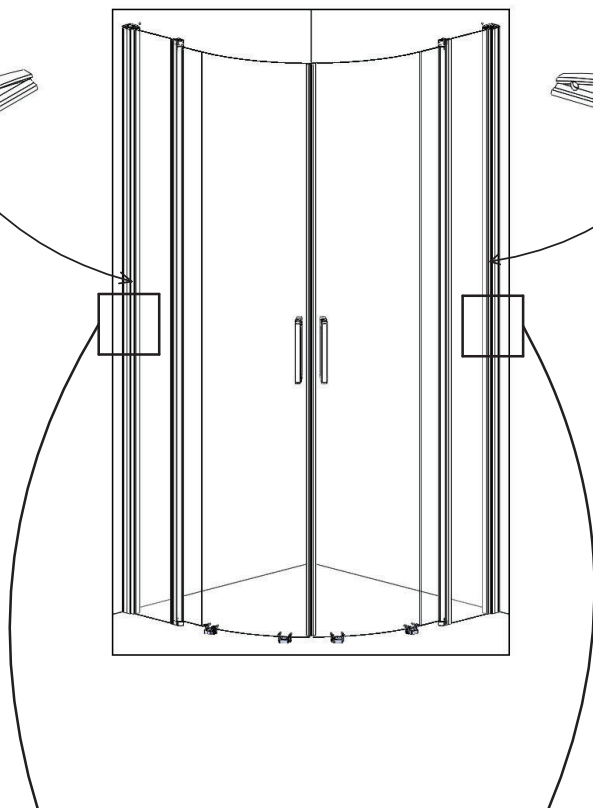
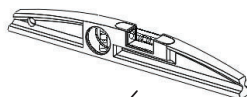
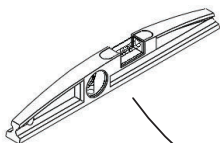
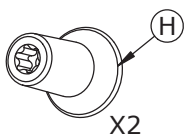

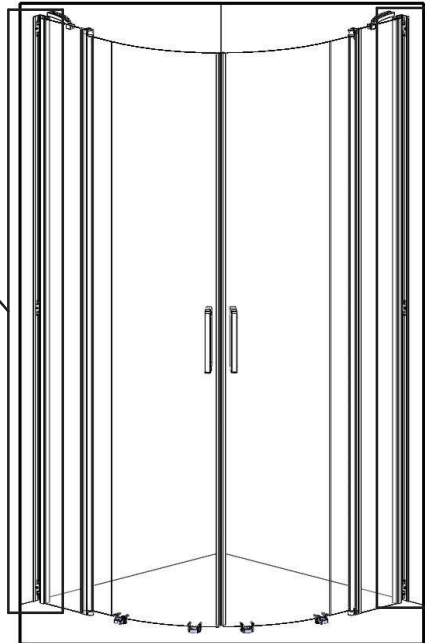
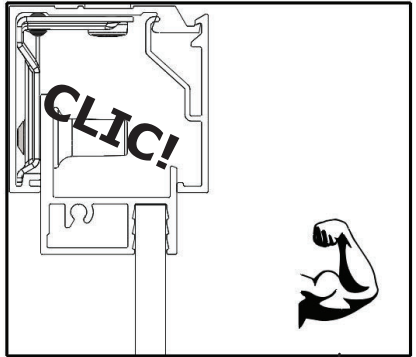
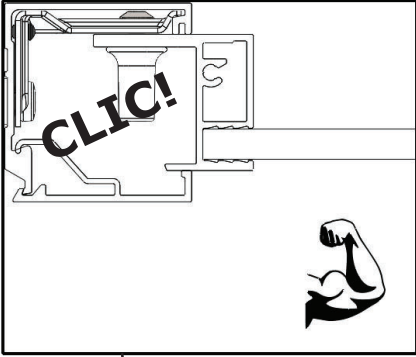
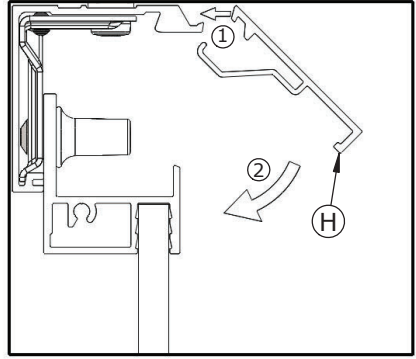
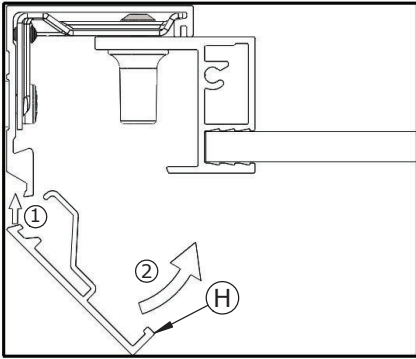

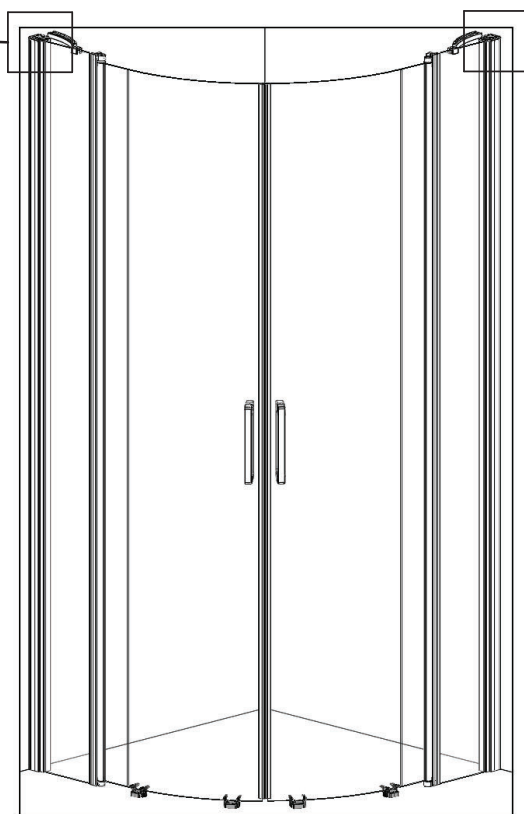
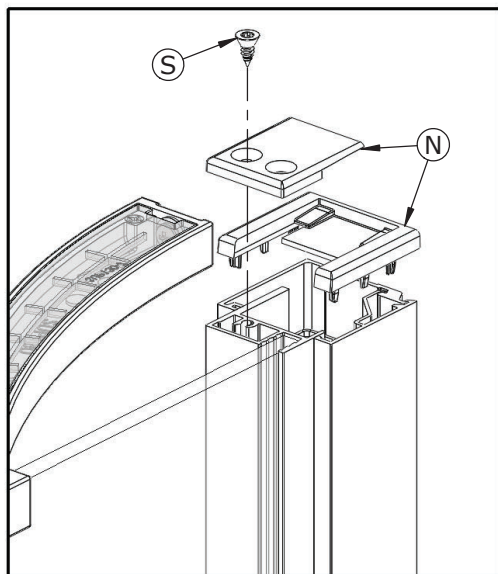
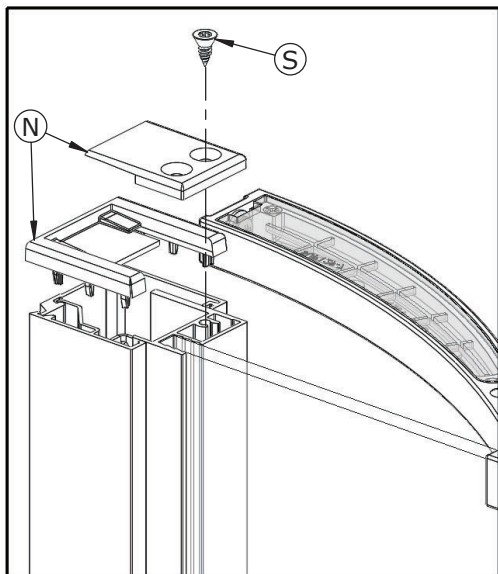

- Retirer (T) ● Remove (T) ● Togliere (T)
● Verwijderen (T) ● Entfernen (T)

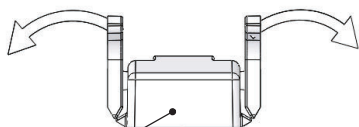

T

X4

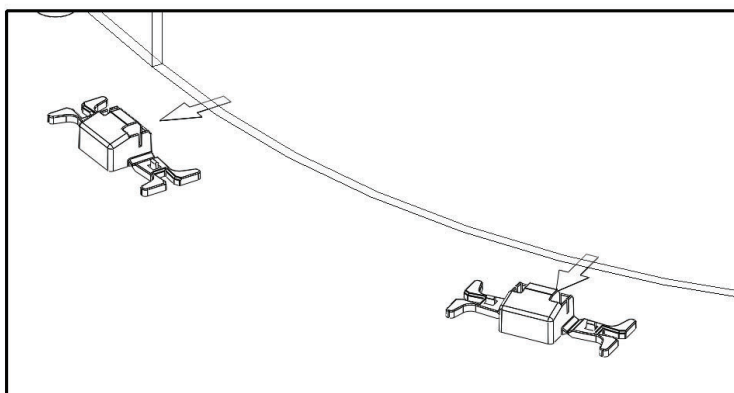
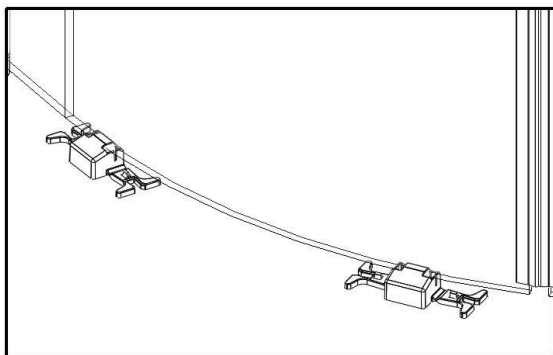
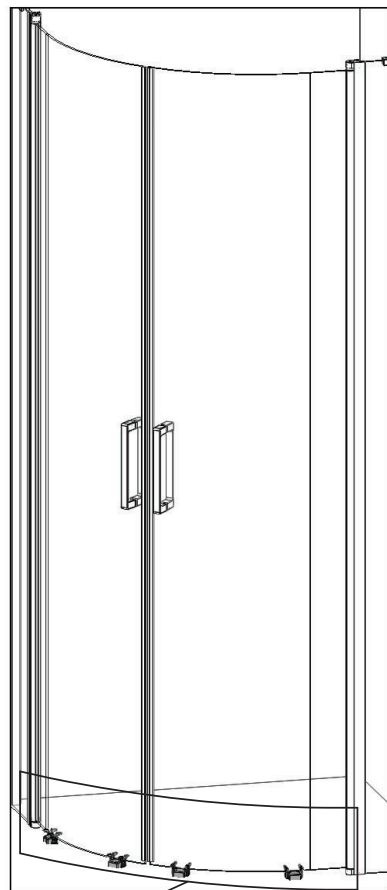

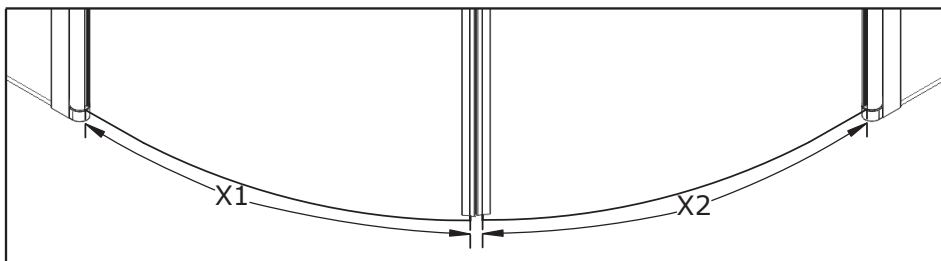

● Intérieur ● Interior
 ● Interno
 ● Binnenzijde ● Innen

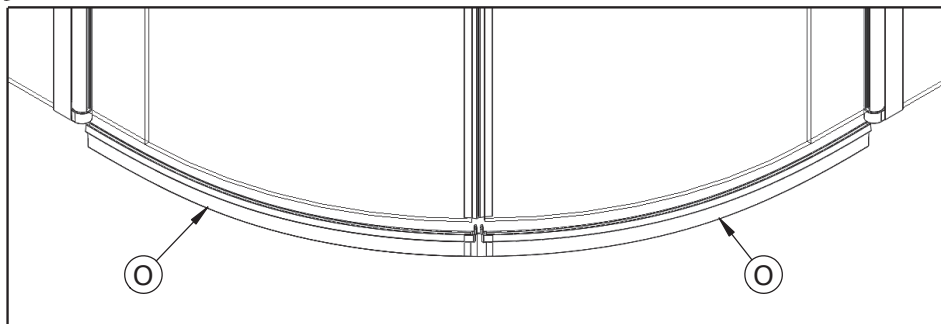
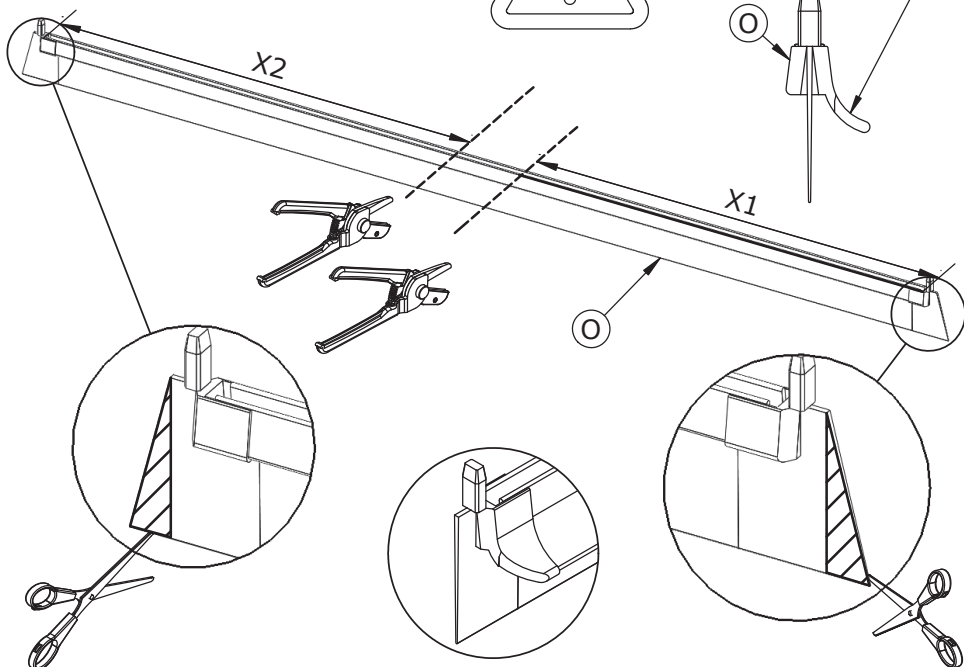

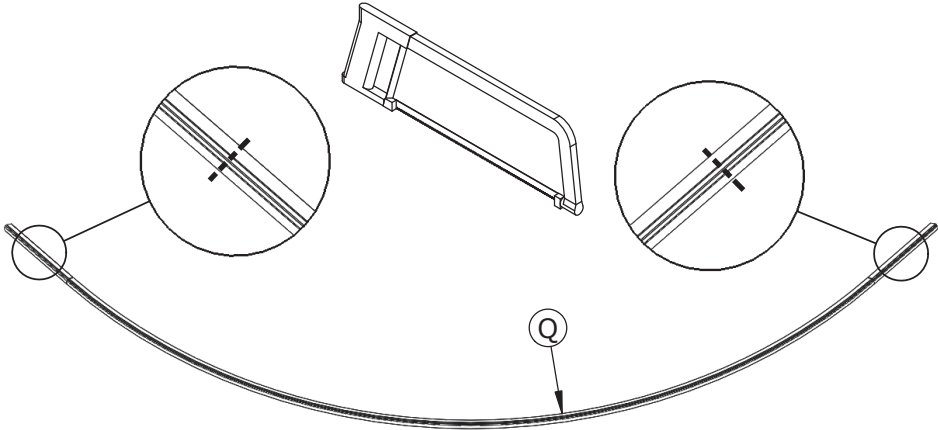
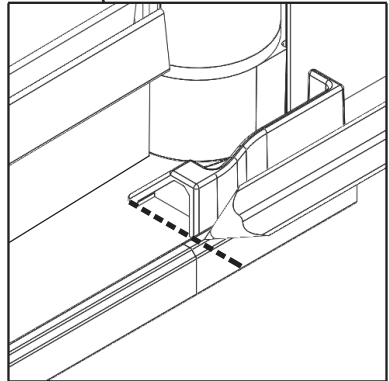
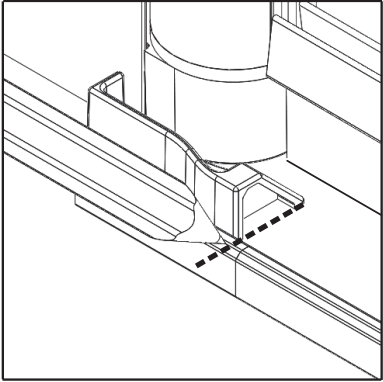
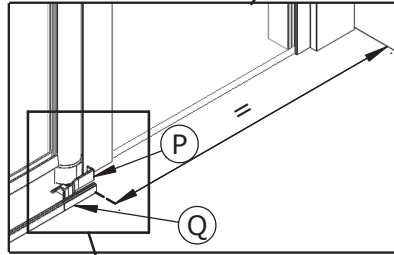
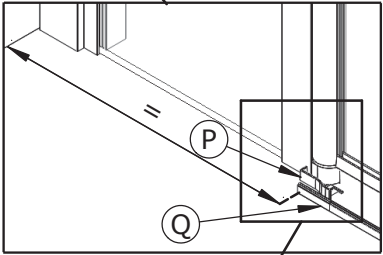
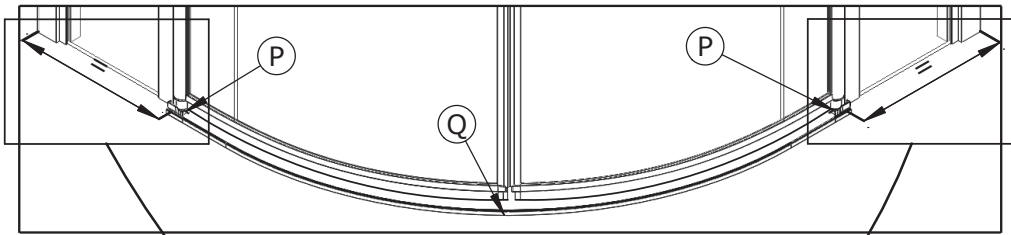

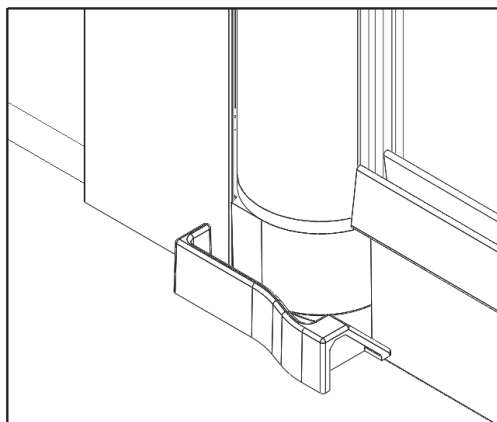
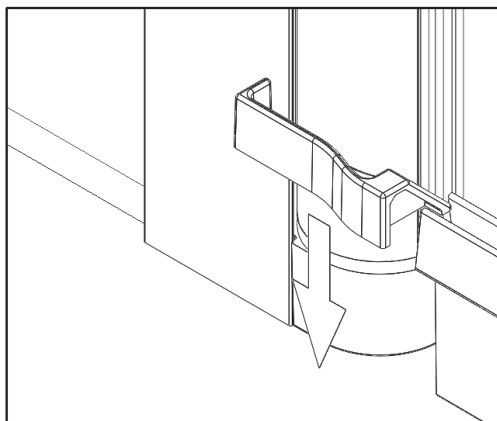
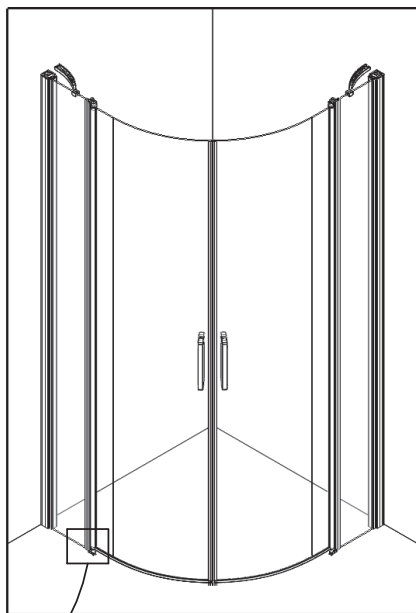
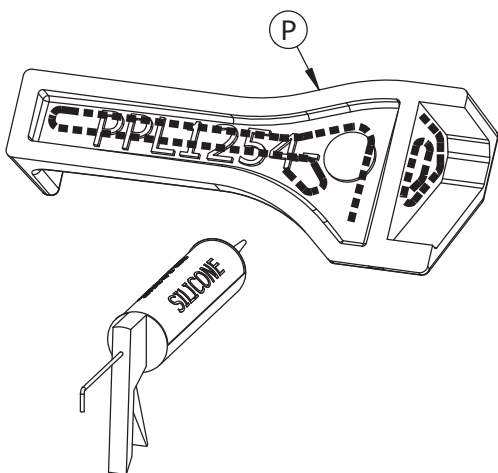

- Extérieur ● Outside ● Esterno
 ● Buitenkant ● Außen

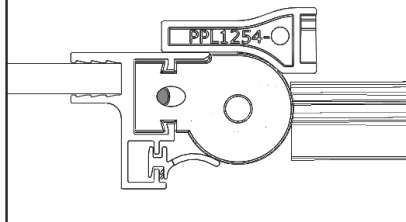

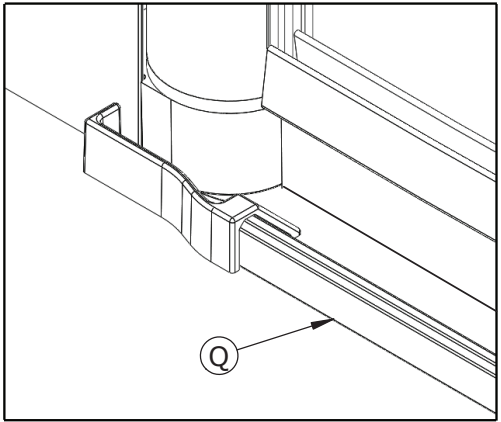
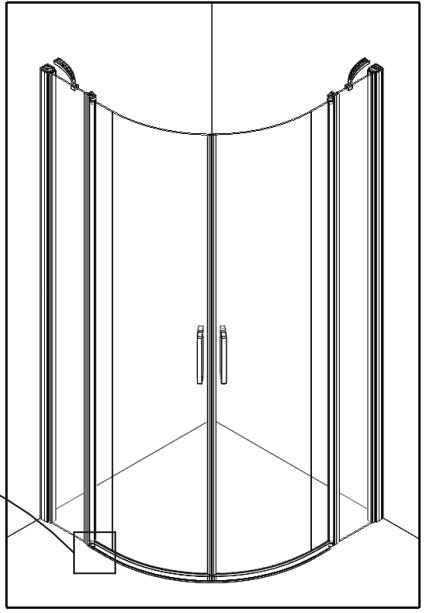
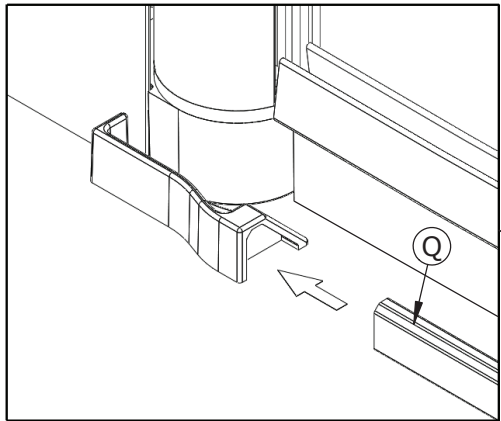
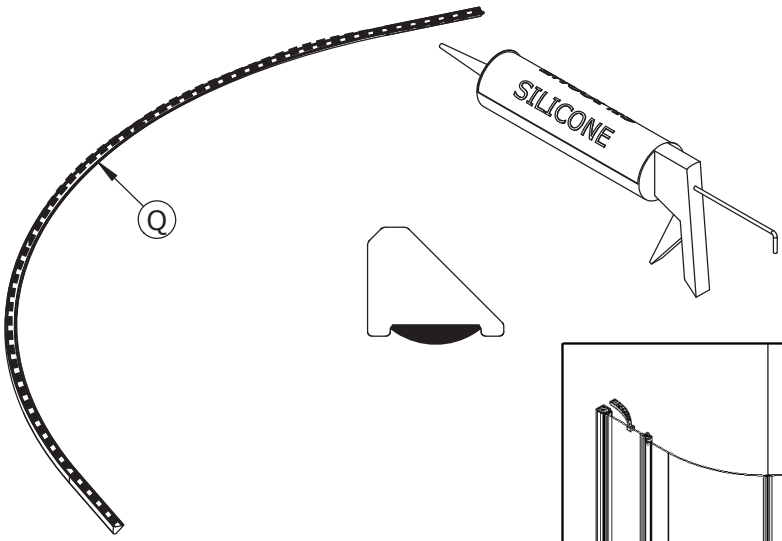

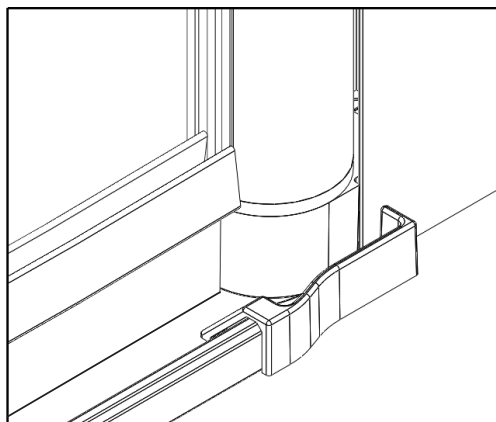
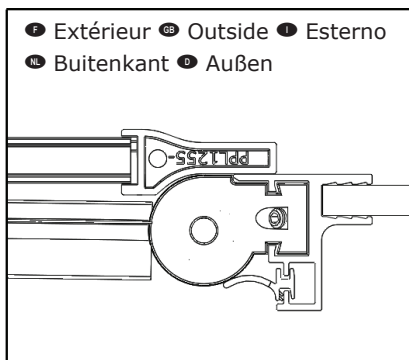
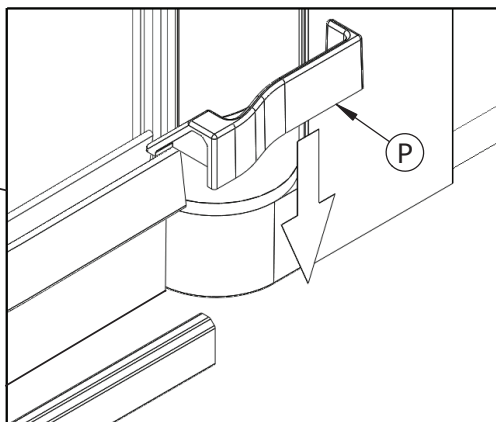
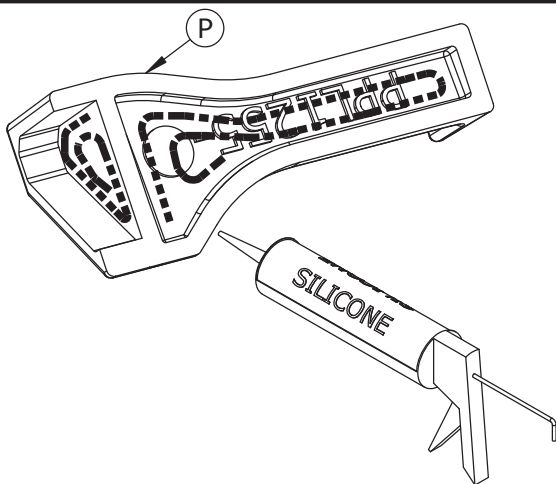
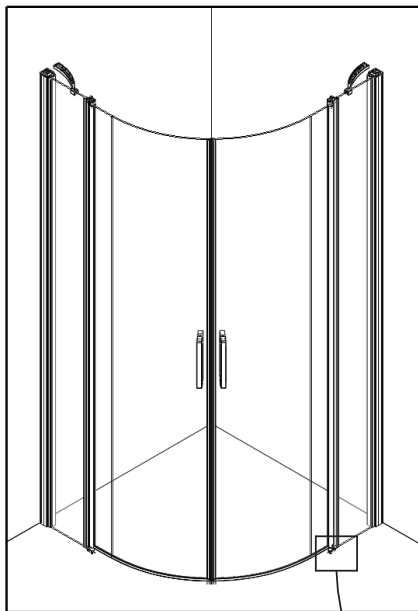

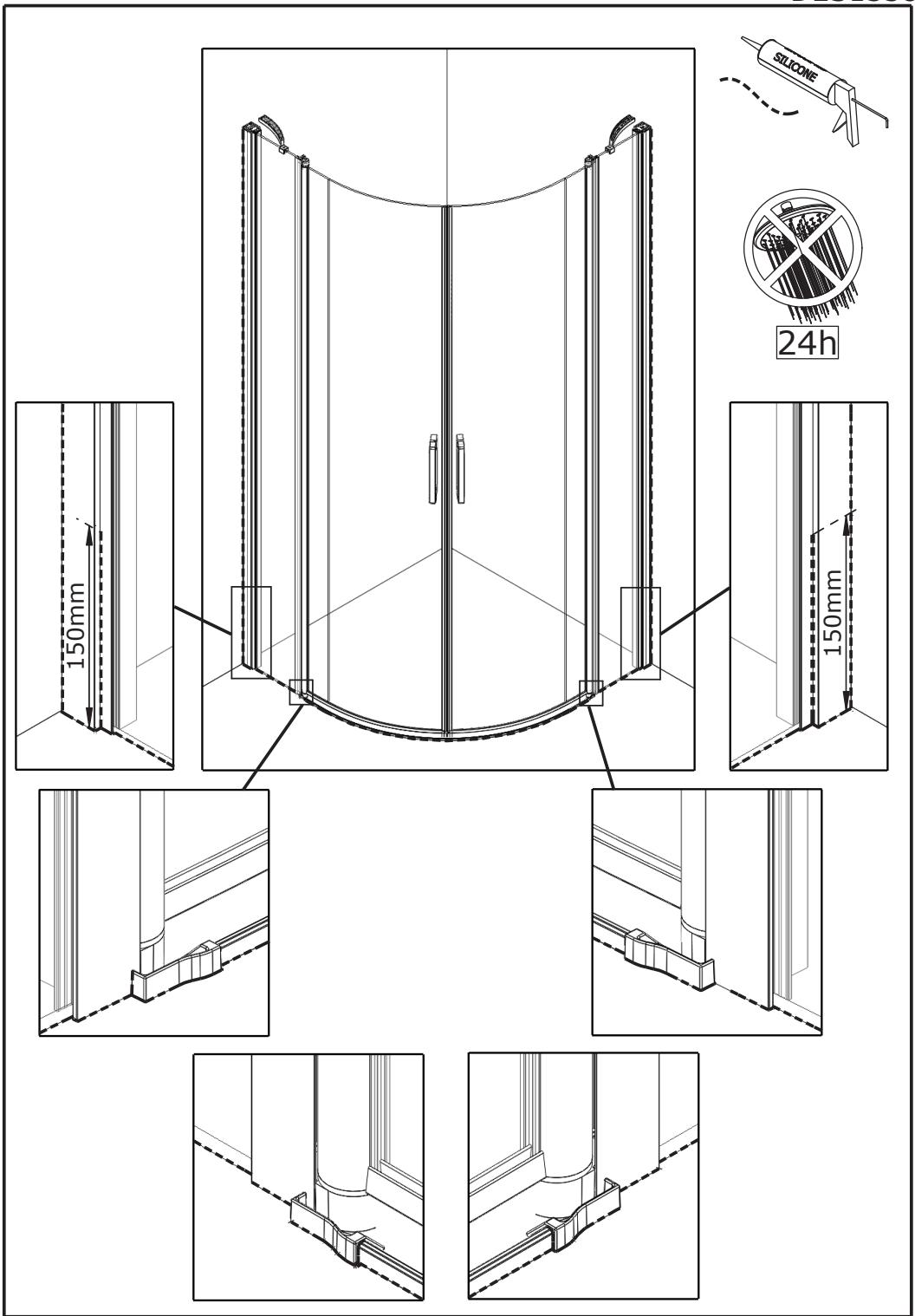



SAV
SERVICE HELPLINES
ASSISTENZA POST-VENTITA
SERVICIO POSTVENTA

FRANCE

02 40 21 29 45

UK

020 8842 0033

IRELAND

04697 33102

DEUTSCHLAND

+49 (0) 6074 / 30928 0

ITALIA

(0382) 6181

OSTEREICH

+43 1 710 60 70

SCHWEIZ

(01) 748 17 44

ESPAÑA

93 544 60 76

NEDERLAND

+31 475 487 100

BELGIE

+31 475 487 100

BELGIQUE

+31 475 487 100

РОССИЯ

963 19 40, 773 67 22



AQUAPRODUCTION, Site industriel,
 F - 44680 Chaumes-en-Retz

18

EN 14428

Paroi de douche, fabriquée en verre de silicate
 sodo-calcique de sécurité trempé thermiquement

Aptitude au nettoyage : réussite

Résistance à l'impact/propriétés de fragmentation : réussite

Durabilité : réussite