

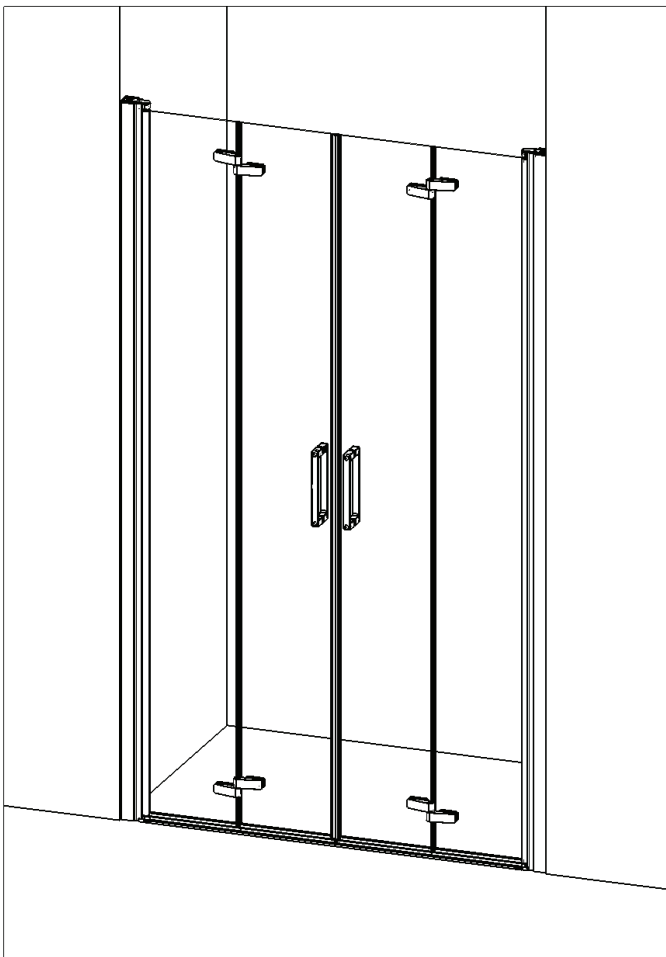



Notre service technique est  
à votre écoute aux numéros  
qui sont au dos de cette  
notice d'installation

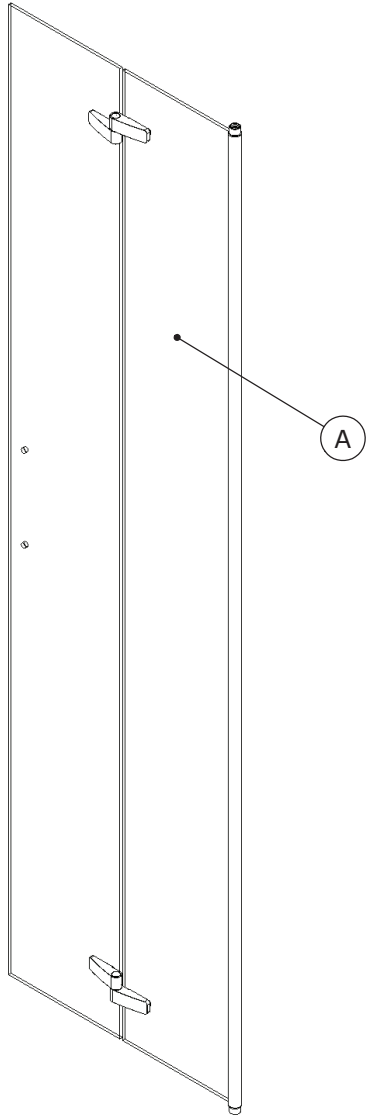
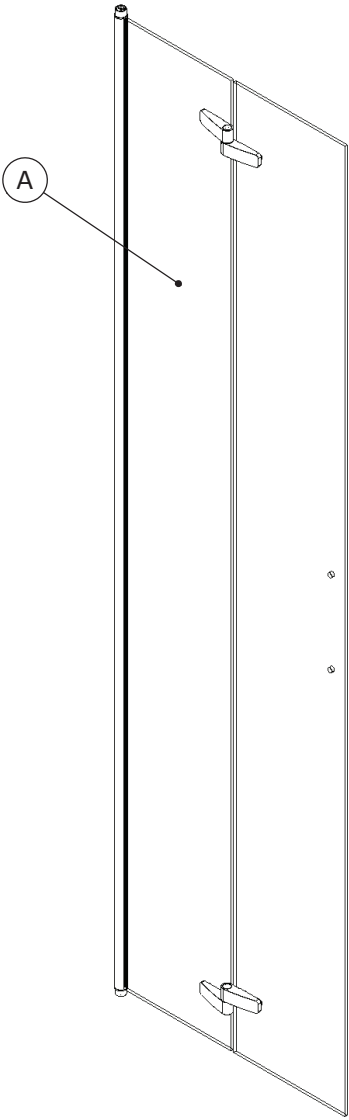

- F Attention aux étapes :
- GB Check installation steps :
- E Atención a los pasos :
- I Attenzione ai passi :
- NL Aandacht voor de stappen :
- D Achtung vor den Schritten :

P. 5 - 14 - 24

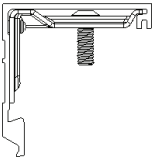
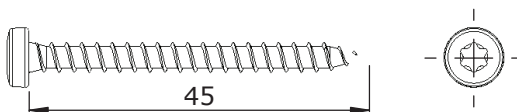
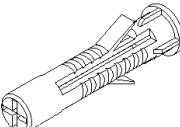
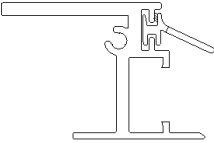
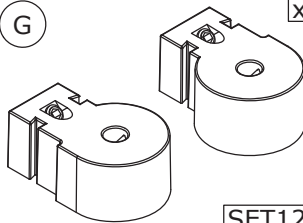
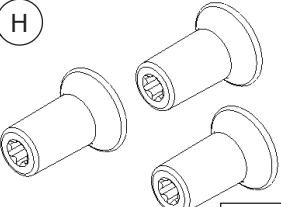
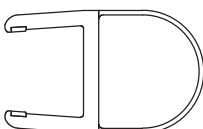
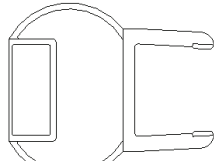
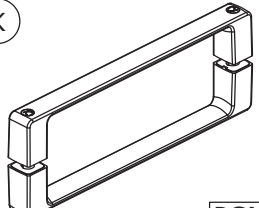

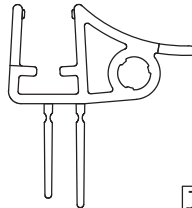
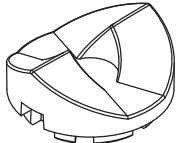
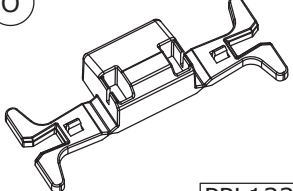
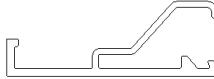
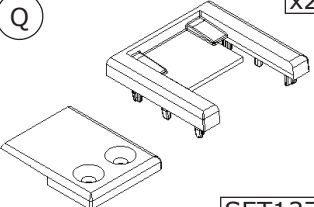
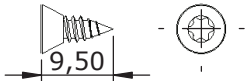
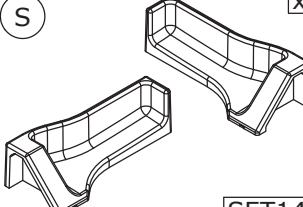
<p><b>C</b> x2</p>  <p>6268</p>	<p><b>D</b> Ø4 x6</p>  <p>45</p> <p>VIS231</p>	
<p><b>E</b> x6</p>  <p>CHE02</p>	<p><b>F</b> x2</p>  <p>6272</p>	<p><b>G</b> x2</p>  <p>SET128</p>
<p><b>H</b> x2</p>  <p>SET134</p>	<p><b>I</b> x2</p>  <p>Lg=1962mm</p> <p>J808</p>	<p><b>J</b> x2</p>  <p>Lg=1962mm</p> <p>AI178</p>
<p><b>K</b> x2</p>  <p>PGN49</p>	<p><b>L</b> x4</p>  <p>BUT44</p>	<p><b>M</b> x2</p>  <p>J806</p>
<p><b>N</b> x2</p>  <p>PPL1248</p>	<p><b>O</b> x4</p>  <p>PPL1339</p>	<p><b>P</b> x2</p>  <p>6270</p>
<p><b>Q</b> x2</p>  <p>SET137</p>	<p><b>R</b> Ø3.5 x2</p>  <p>9,50</p> <p>VIS261</p>	<p><b>S</b> x1</p>  <p>SET140</p>

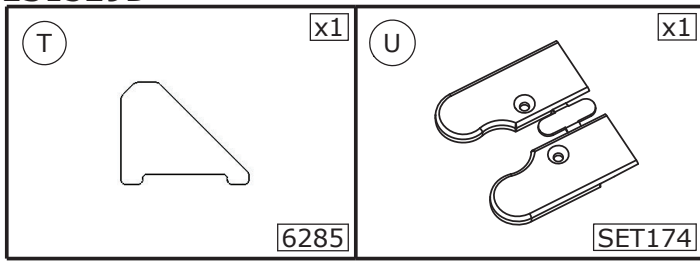

- Les quantités données sont les quantités utiles au montage. les sachets fournis contiennent des pièces supplémentaires.
- The quantities given are what are required for the installation. There may be some surplus in the package provide.
- Las cantidades indicadas son las cantidades necesarias para el montaje. Las bolsitas incluidas contienen piezas suplementarias.
- Le quantità fornite sono le quantità necessarie al montaggio. I sacchetti forniti contengono pezzi supplementari.
- De aangegeven aantallen zijn vereist voor de montage. De verpakking bevat extra onderdelen.
- Die Mengen sind die benötigten Mengen für die Montage. Die Verpackung enthält zusätzliche Teile.

- **Outillage nécessaire / Tools required / Equipamiento necesario**
- **Attrezzatura necessaria / Benodigde gereedschap / Werkzeuge erforderlich**

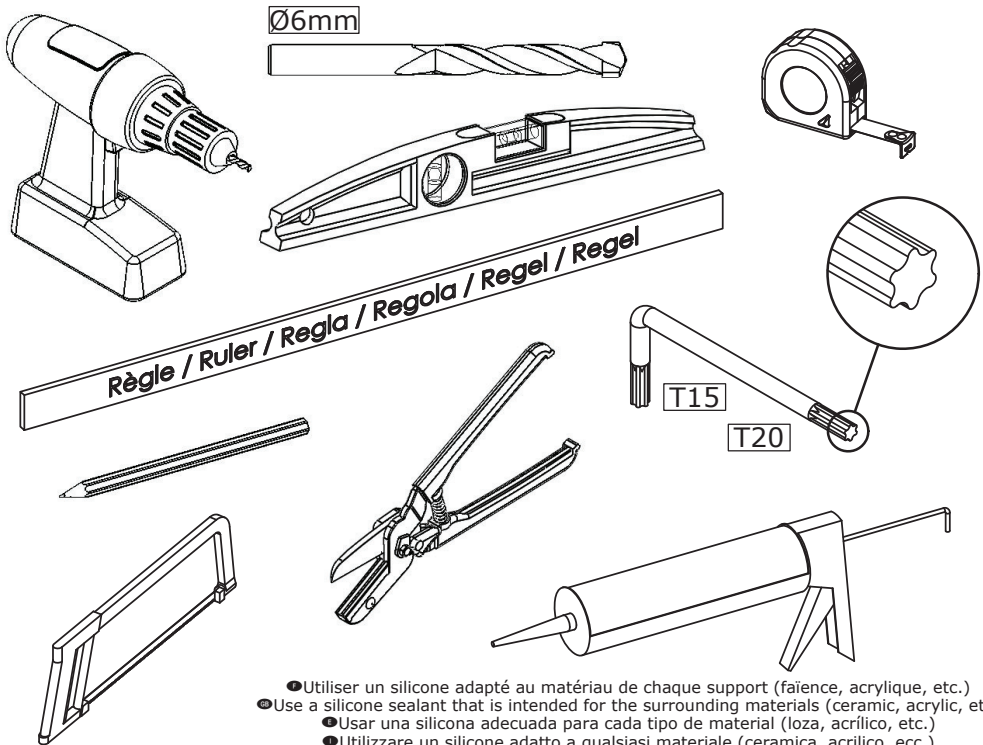

- Utiliser un silicone adapté au matériau de chaque support (faïence, acrylique, etc.)
- Use a silicone sealant that is intended for the surrounding materials (ceramic, acrylic, etc.)
- Usar una silicona adecuada para cada tipo de material (loza, acrílico, etc.)
- Utilizzare un silicone adatto a qualsiasi materiale (ceramica, acrilico, ecc.)
- Gebruik siliconenkit die geschikt is voor iedere ondergrond (tegelwerk, acryl, etc.)
- Für das jeweilige Trägermaterial (Stein, Acryl usw.) geeignetes Silikon verwenden.



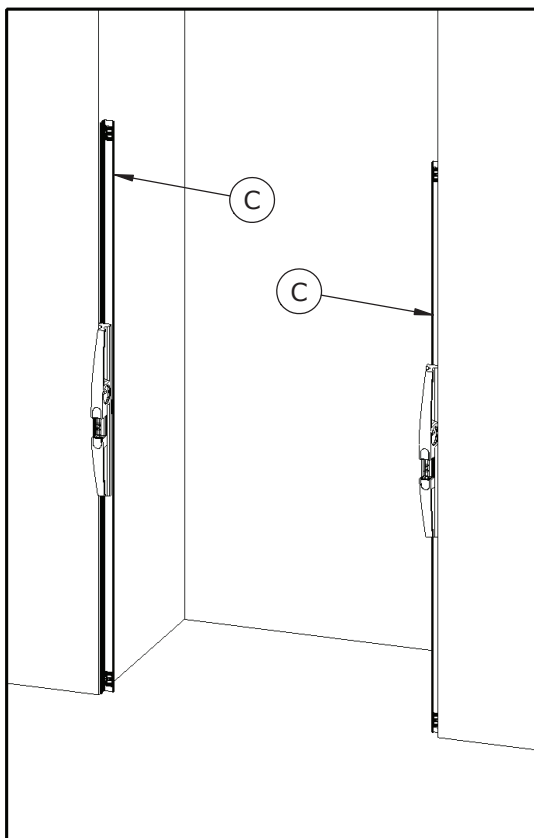

- F Si receveur • B If shower tray
- E Si plato • I Se piatto
- NL Als douchebak
- D Wenn Duschwanne

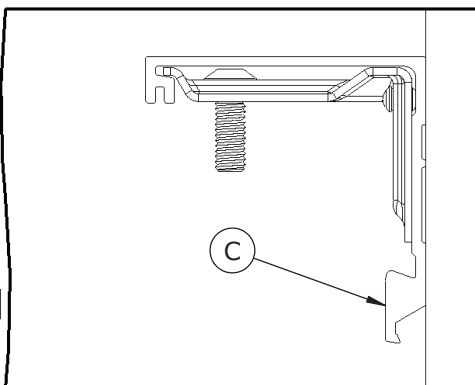
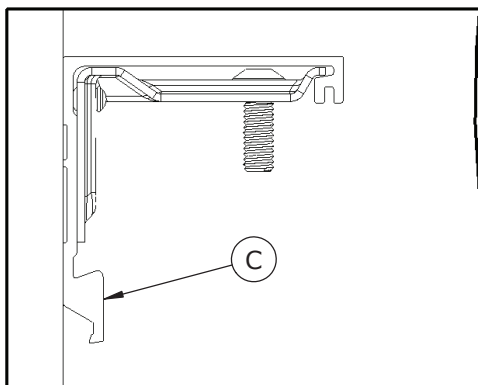
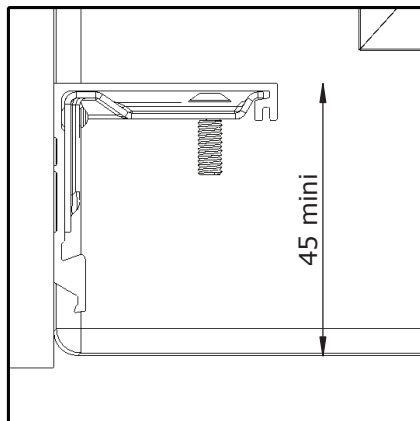

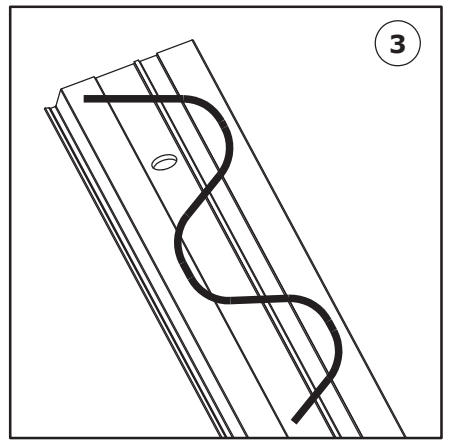
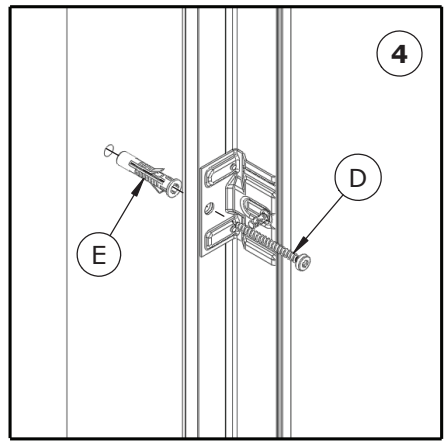
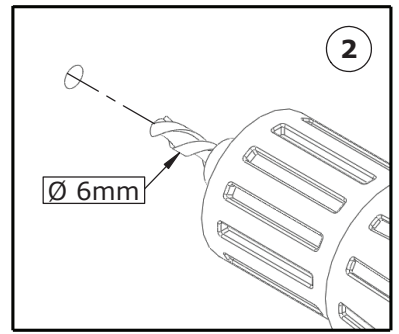
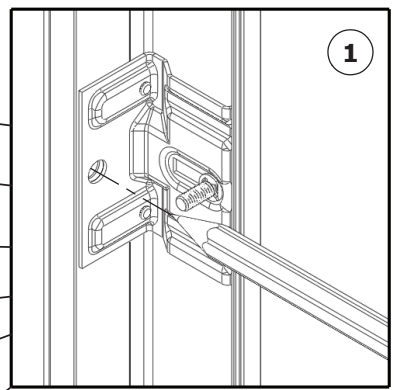
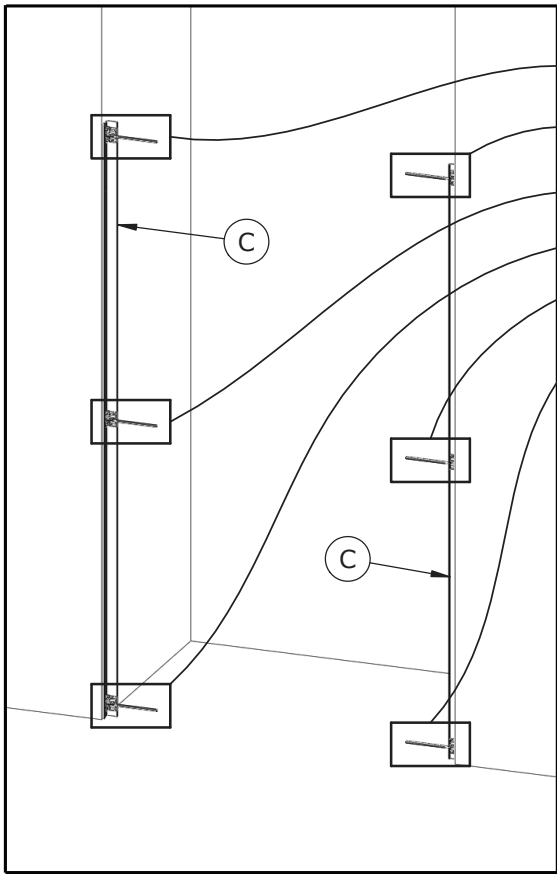

**X2**

- F Affleurant ● GB Flush
- E Afloramiento ● I Affioramento
- NL Doorspoelen ● D Bündig

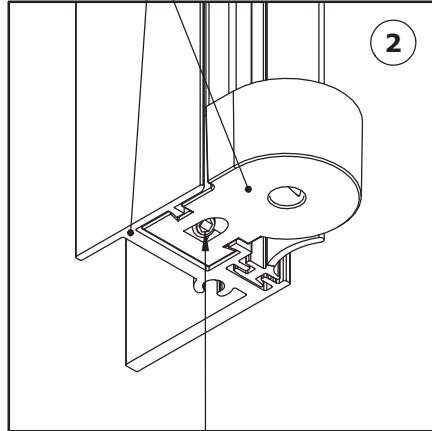

- F Serrer ● GB Tighten
- E Apriete ● I Serrare
- NL Vastdraaien ● D Festziehen

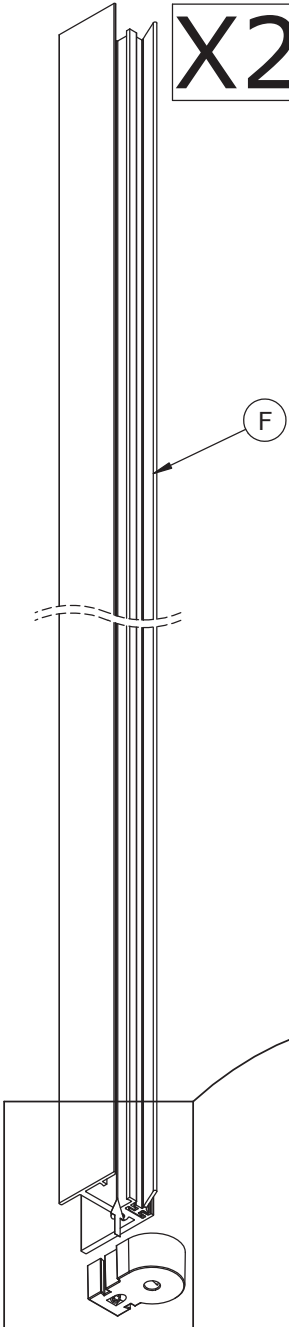
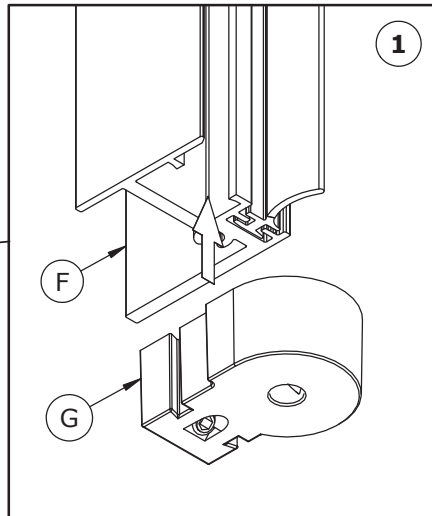

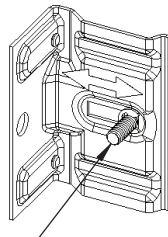
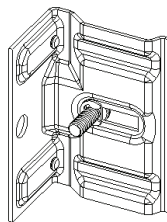
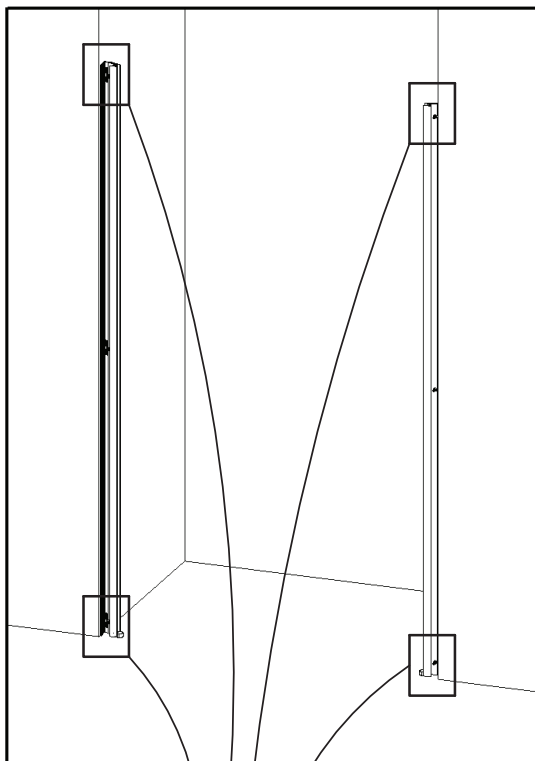

- Si nécessaire, desserrer, régler puis resserrer
- If necessary, loosen, adjust and retighten
- Si es necesario, afloje, ajuste y apriete
- Se necesario, allentare, regolare e stringere
- Draai los, indien nodig, stel af en draai vervolgens weer vast
- Falls erforderlich, lösen, einstellen und wieder festziehen

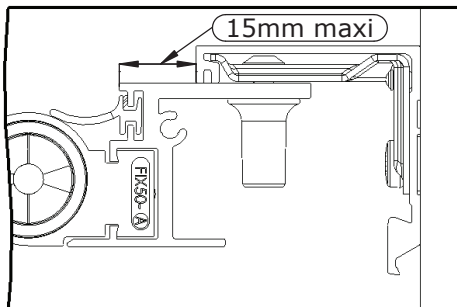
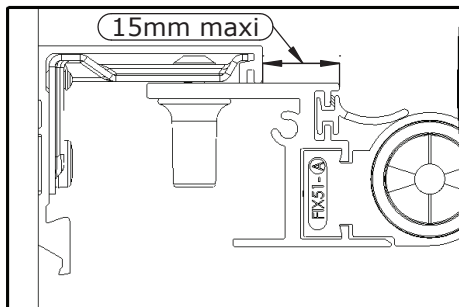
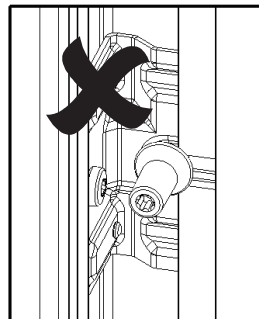
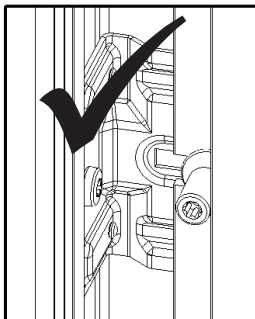
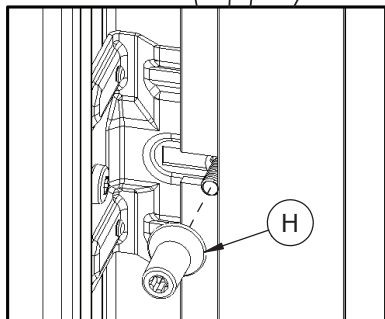



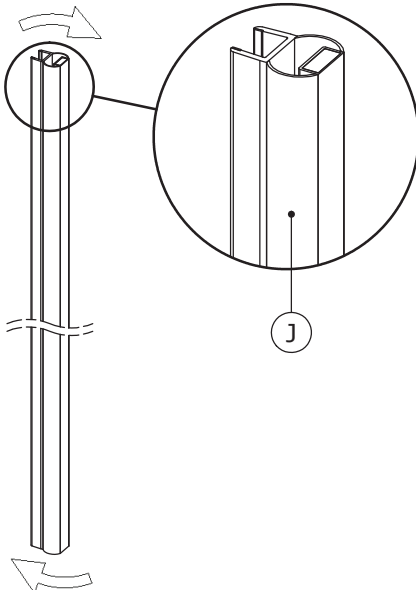
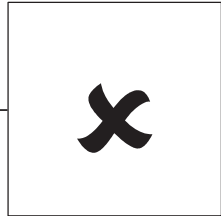
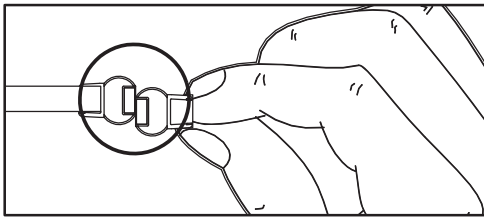
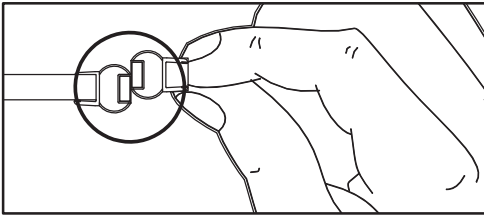
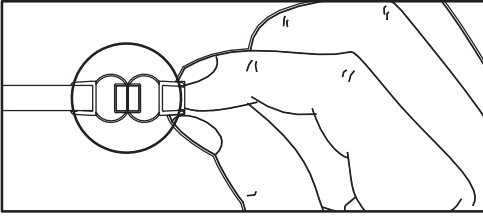

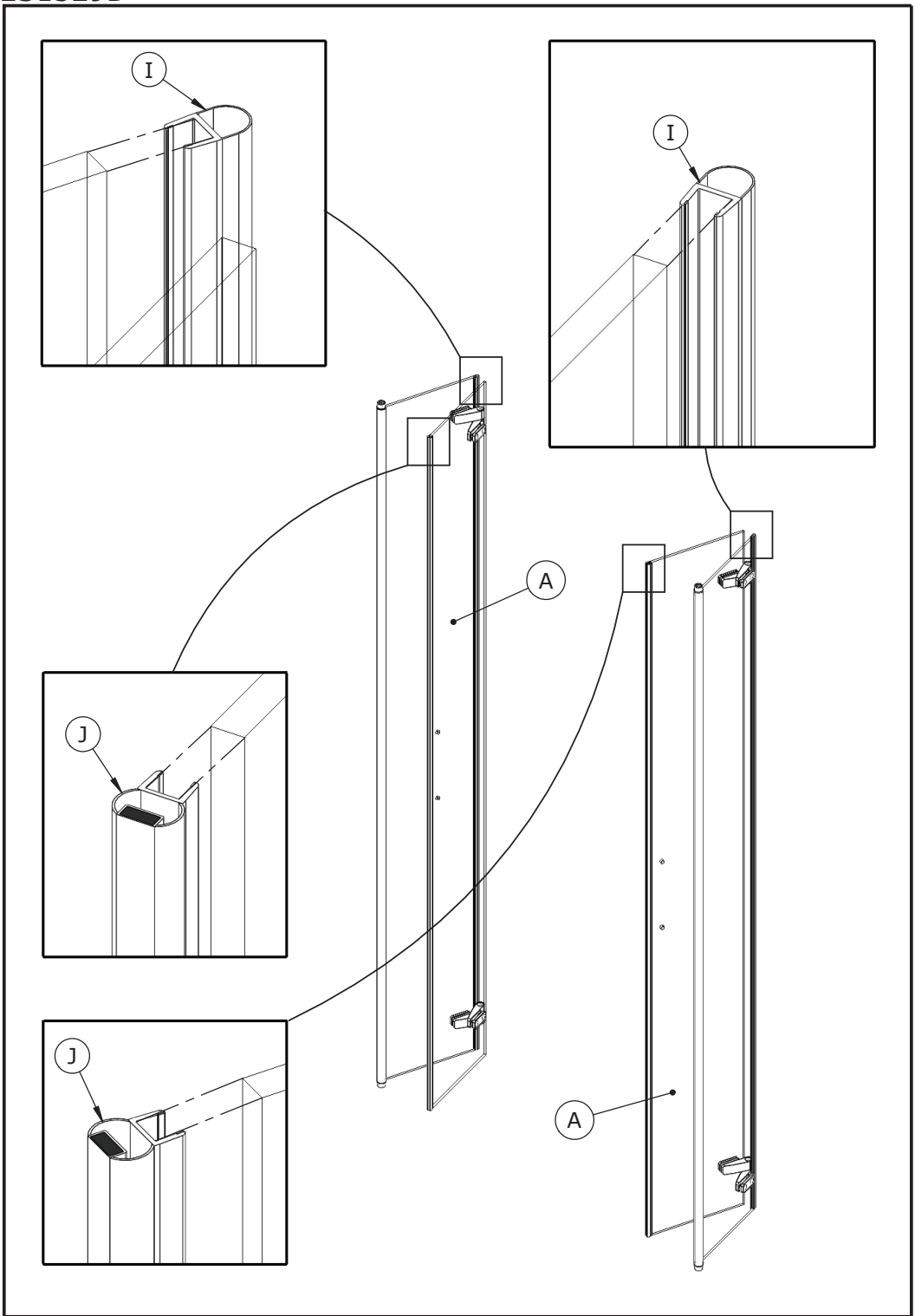

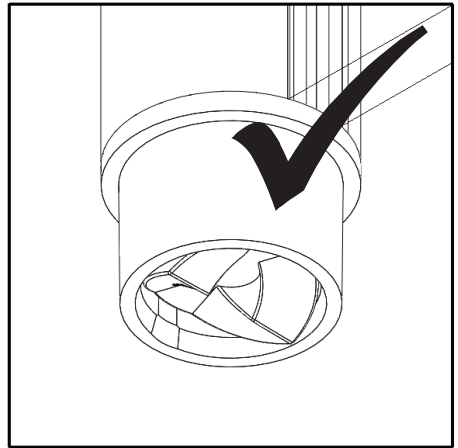
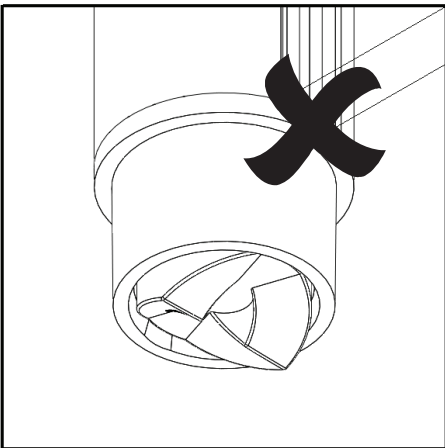
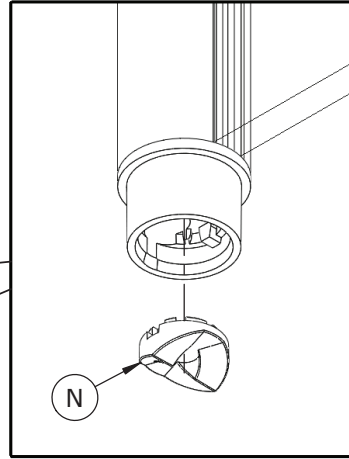
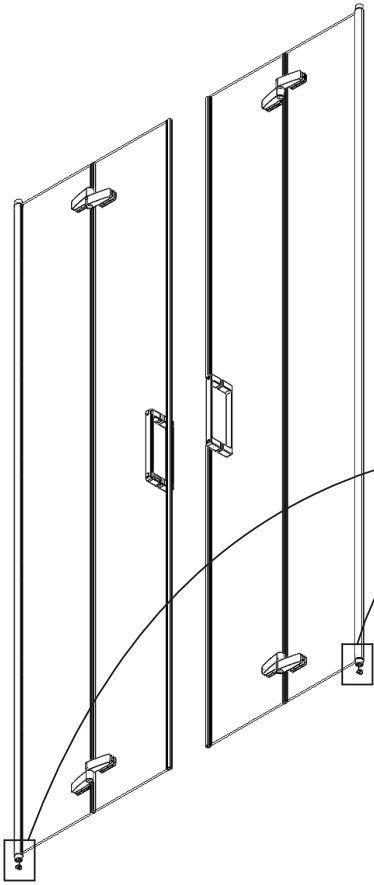

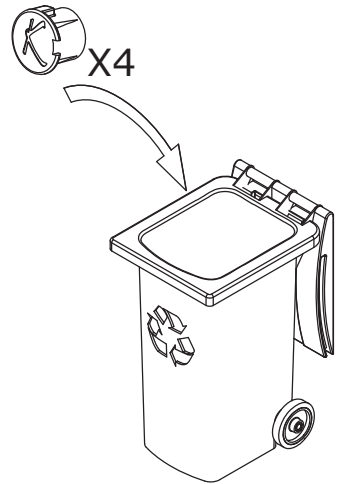
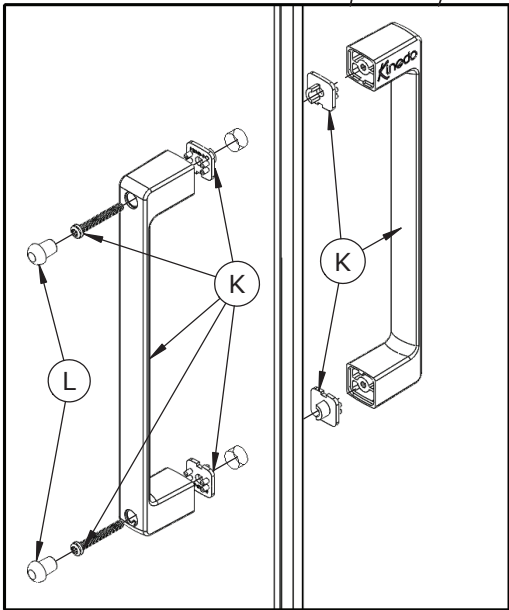
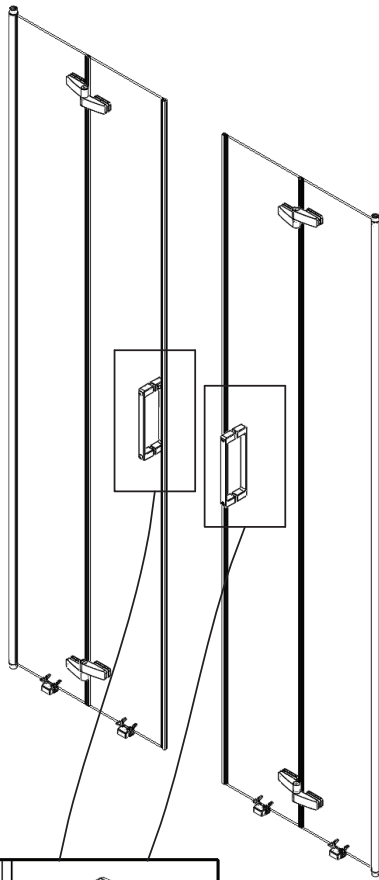

- Réglages des portes ● Adjusting the doors ● regolazione porte
- Deuren afstellen ● Ausrichten und Einstellen der Tür

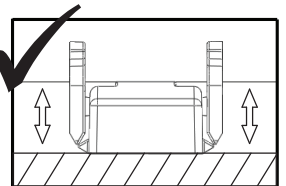
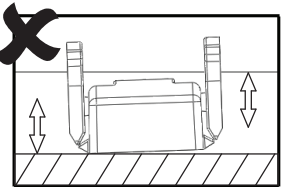
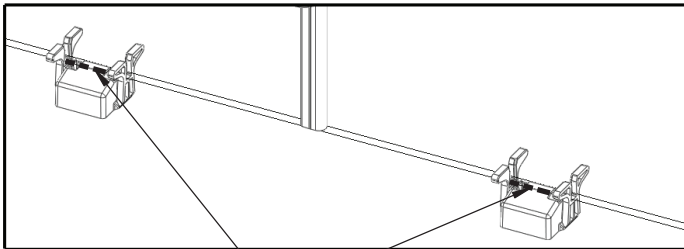
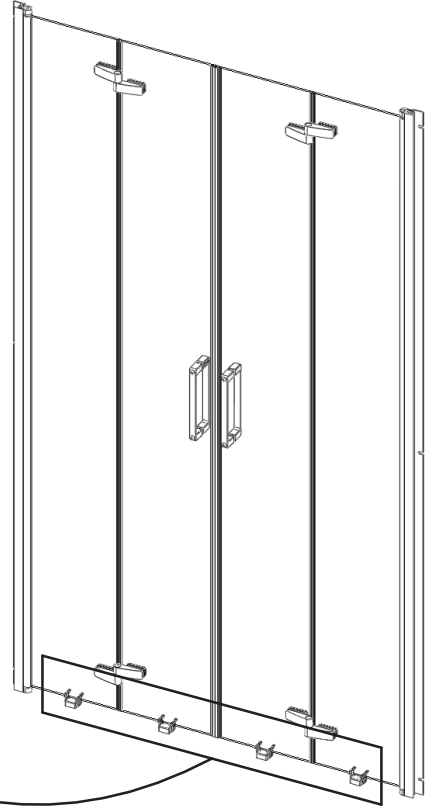
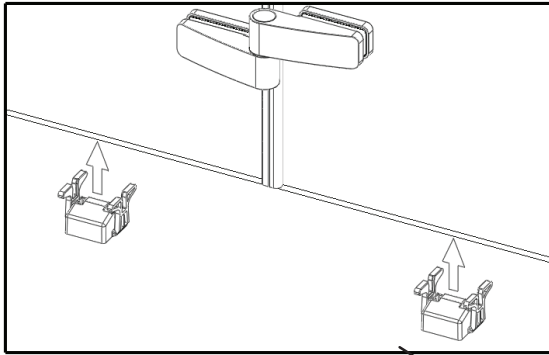
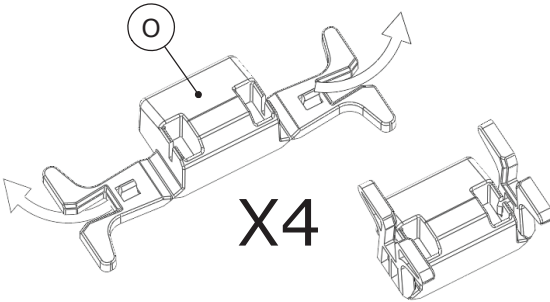

- Mettre en contact
- Put in contact
- Mettere in contatto
- Mensen in contact te brengen
- Kontakte knüpfen

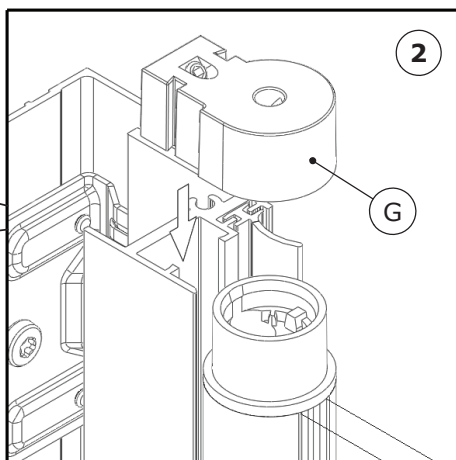
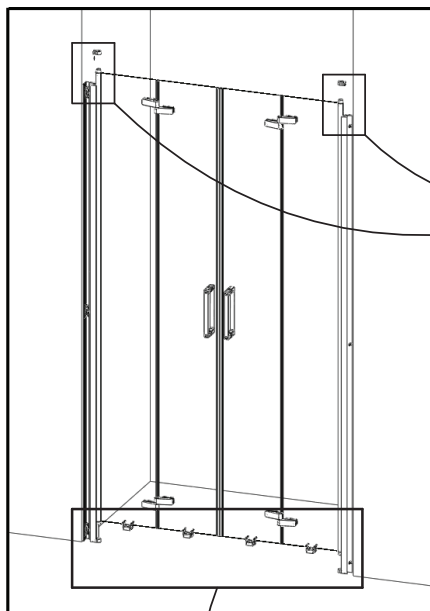

F Affleurant G Flush  
 E Afloramiento P Affioramento  
 NL Doorspoelen D Bündig

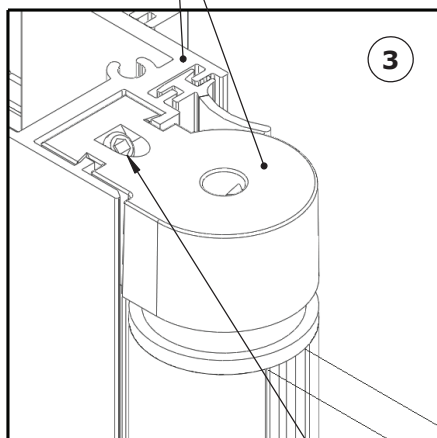
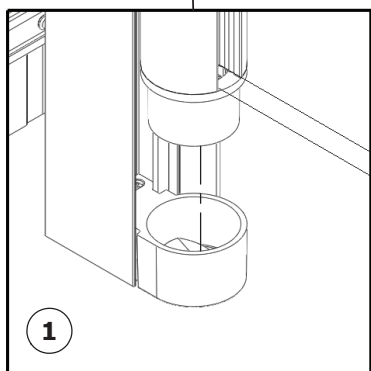

F Serrer G Tighten  
 E Apriete P Serrare  
 NL Vastdraaien D Festziehen



F Intérieur G Inside  
 E Interior P Interno  
 NL Binnenkant D Innen

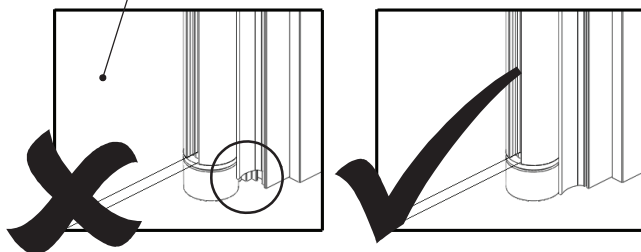

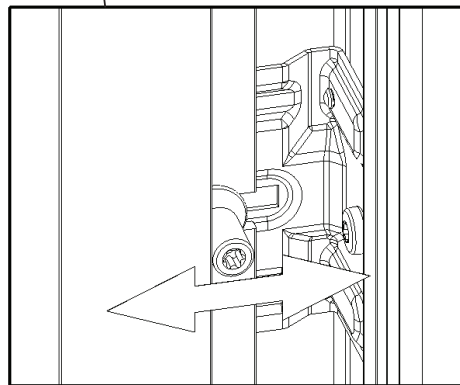
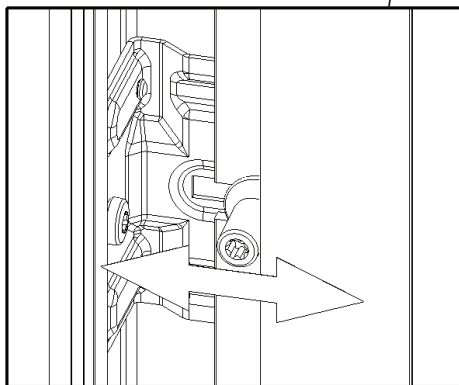
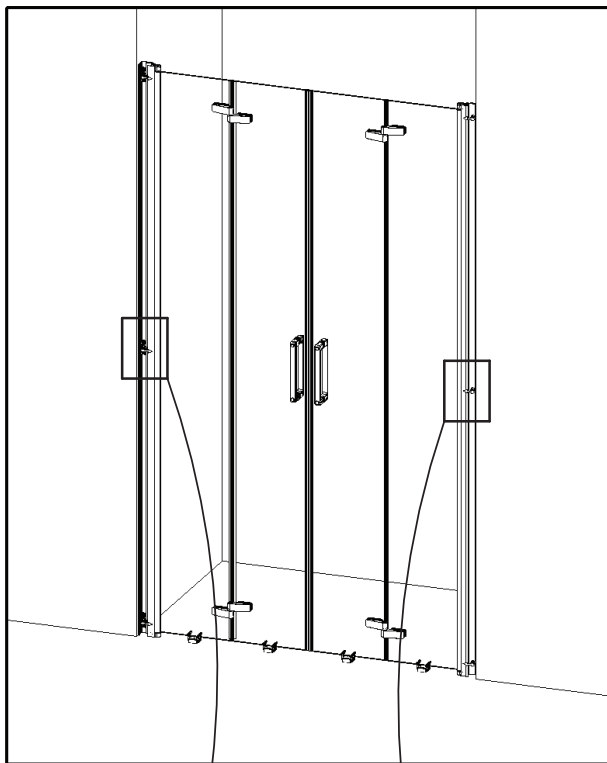

- Si nécessaire, desserrer, régler puis resserrer
- If necessary, loosen, adjust and retighten
- Si es necesario, afloje, ajuste y apriete
- Se necessario, allentare, regolare e stringere
- Draai los, indien nodig, stel af en draai vervolgens weer vast
- Falls erforderlich, lösen, einstellen und wieder festziehen

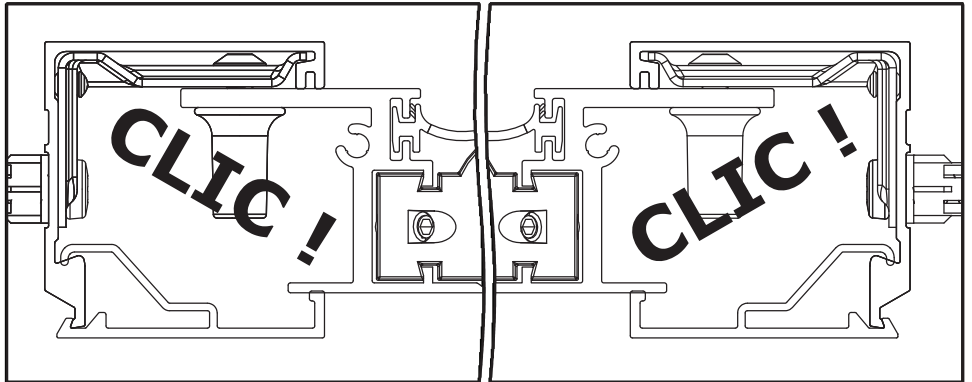
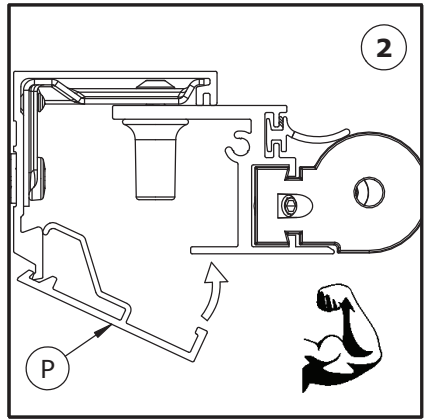
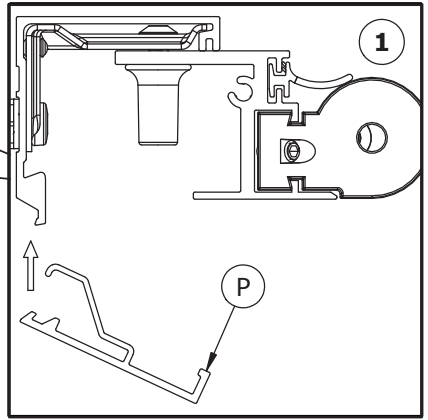
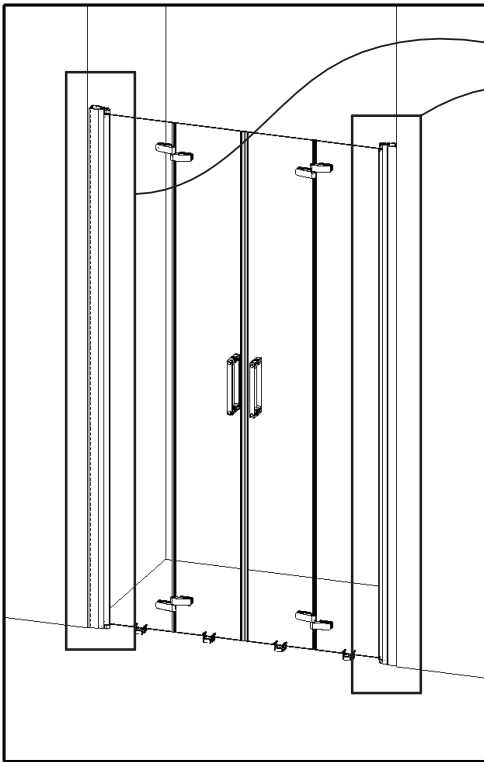



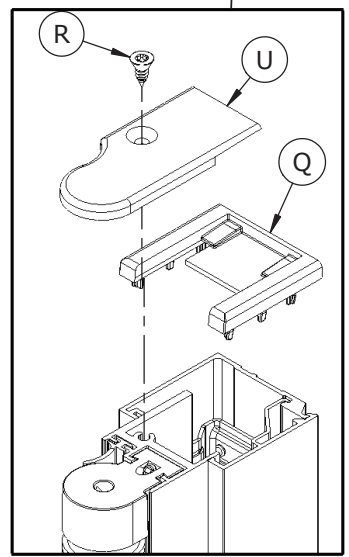
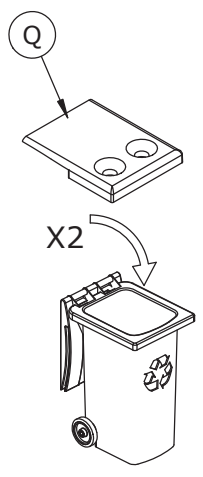
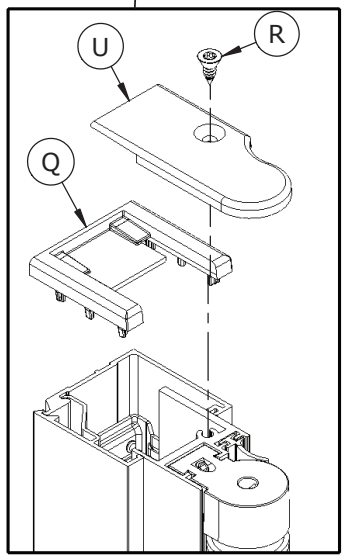
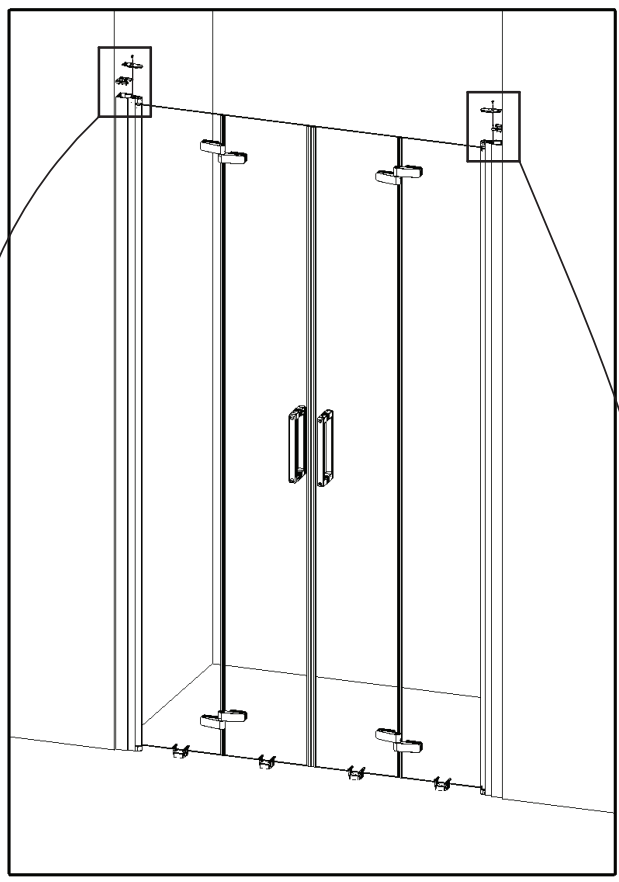

- Retirer (O) ● Remove (O) ● Togliere (O)
- Verwijderen (O) ● Entfernen (O)

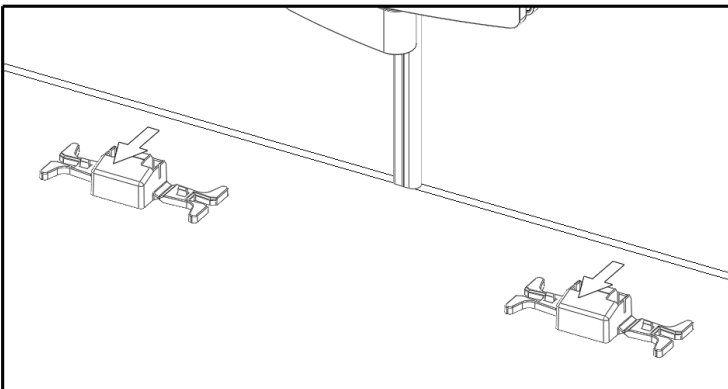
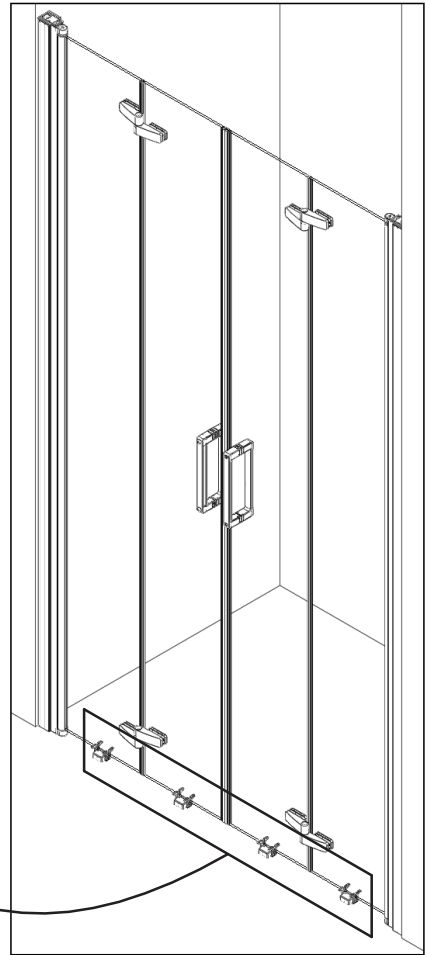
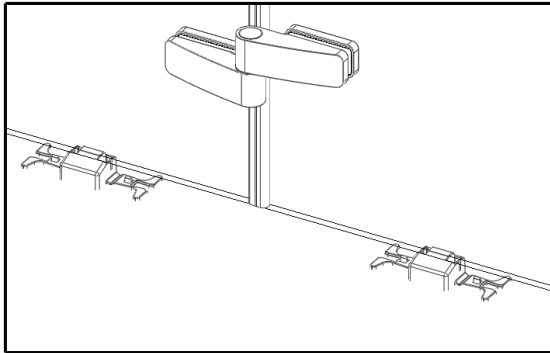
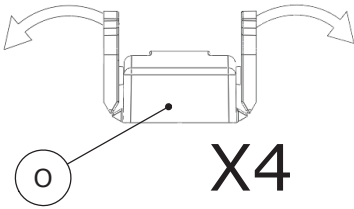

F Intérieur    GB Inside  
 S Interior    I Interno  
 N Binnenkant    D Innen



M

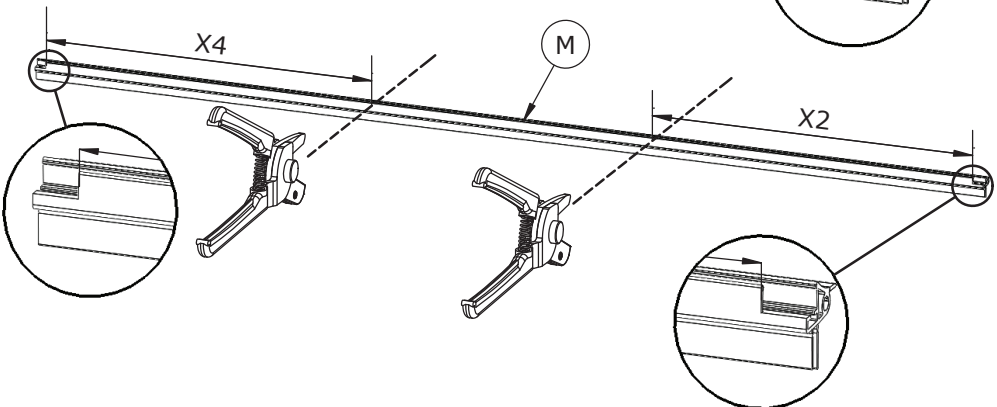
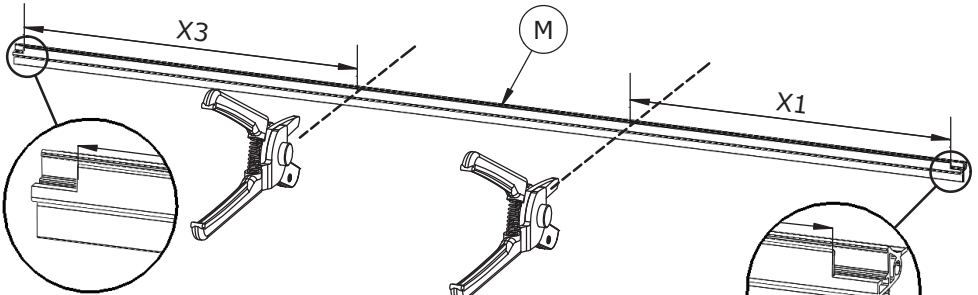
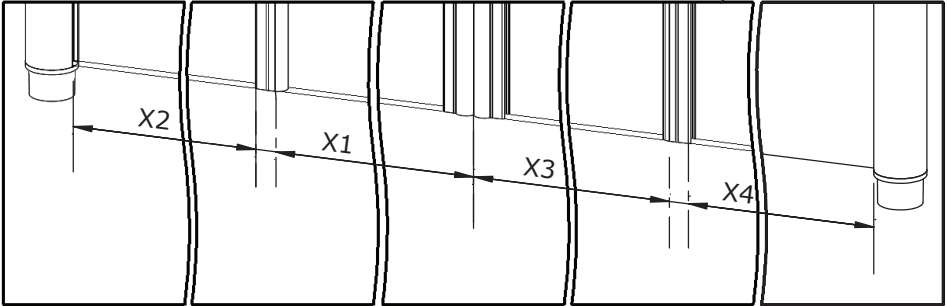
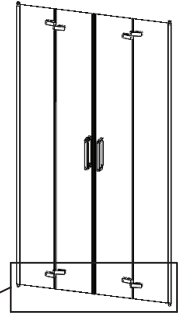
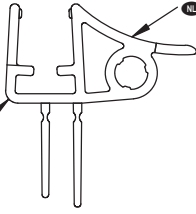



- Intérieur
- Ⓢ Inside
- Interior
- Interno
- Binnenkant
- Innen

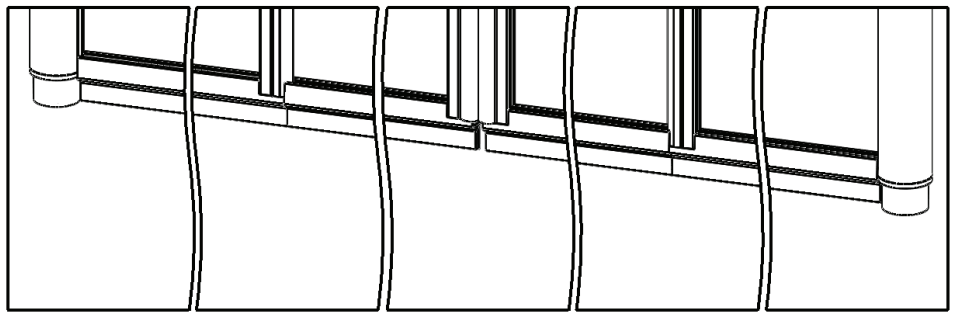
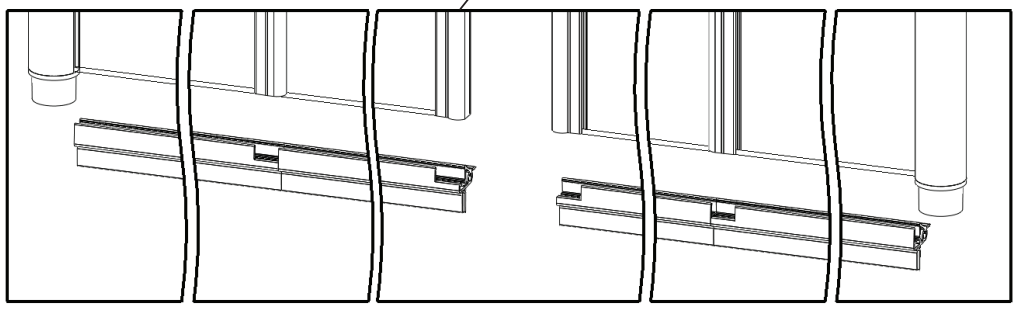
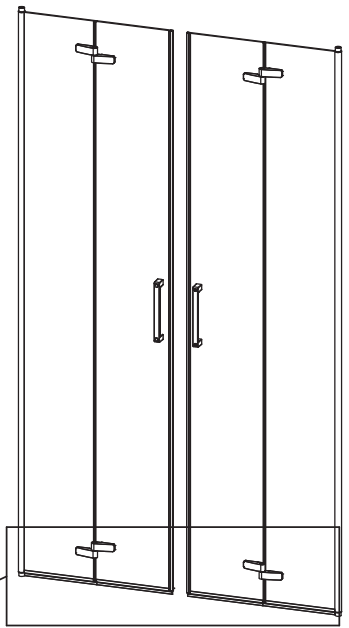
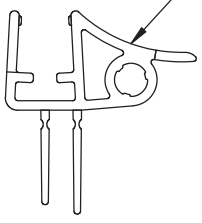

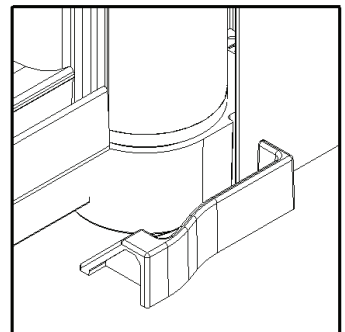
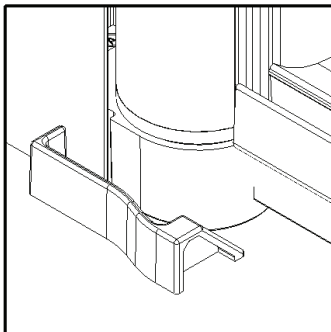
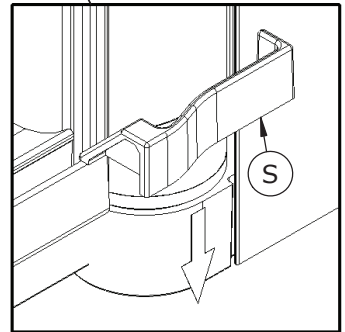
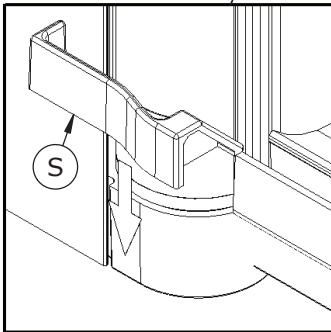
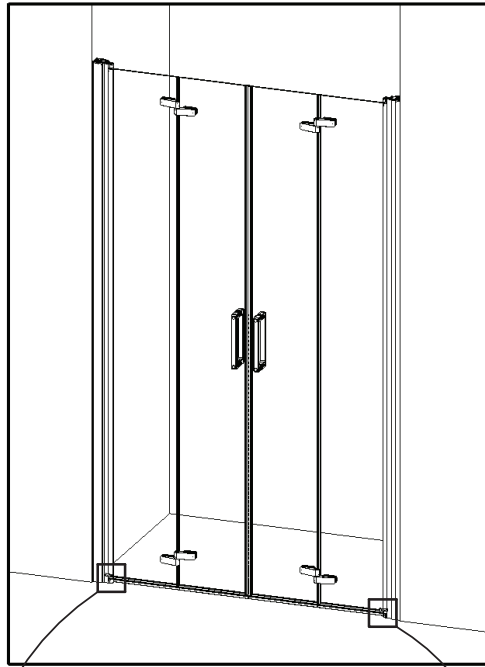

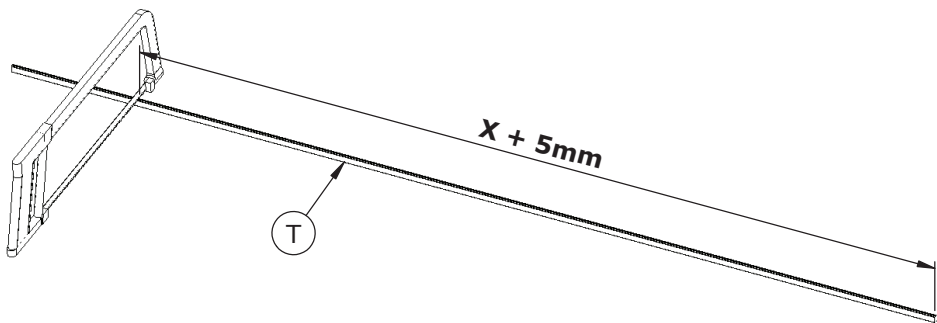
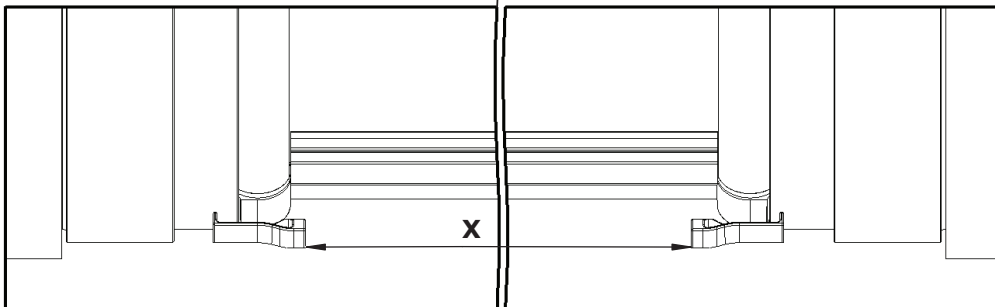
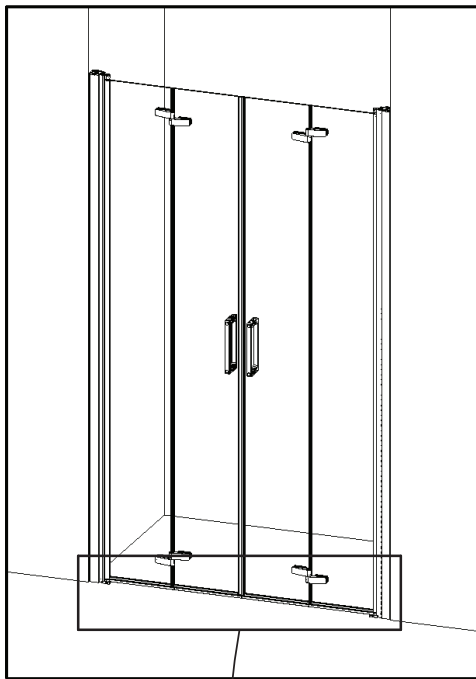

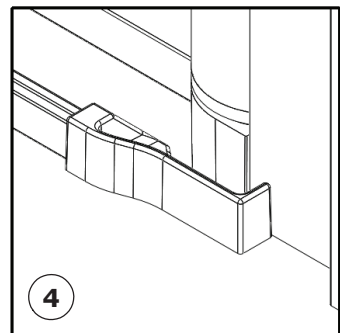
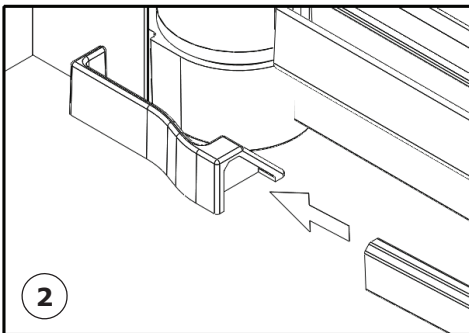
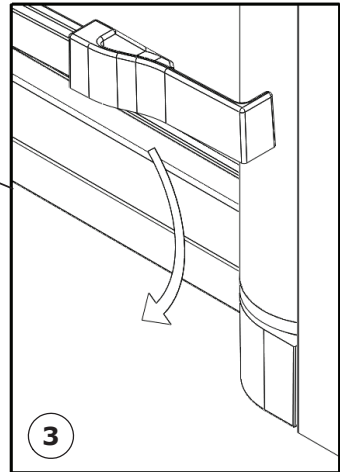
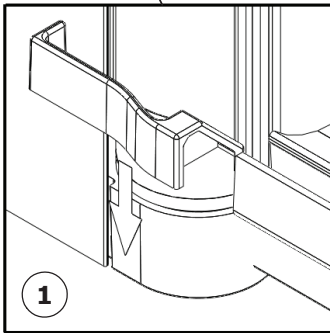
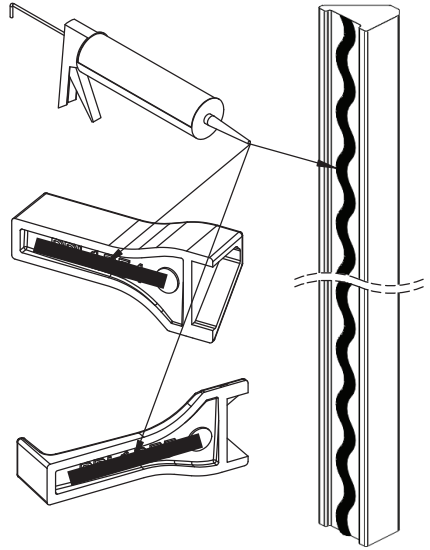
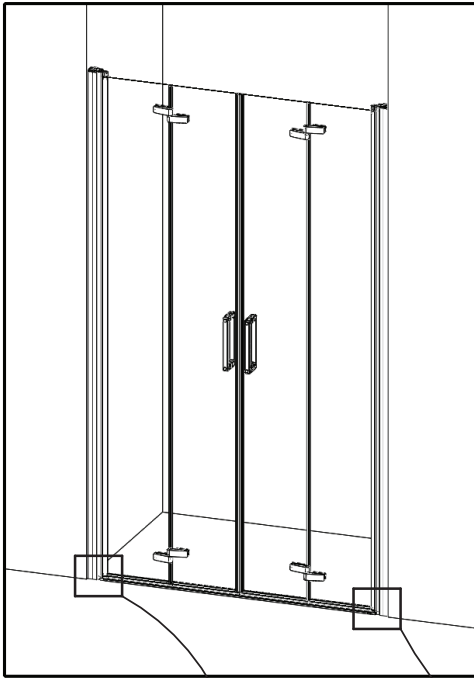

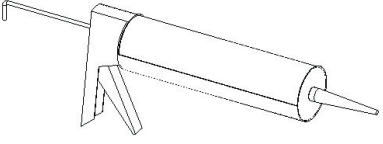

24H

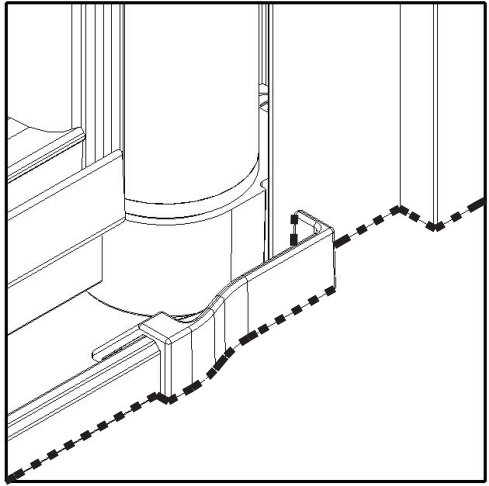
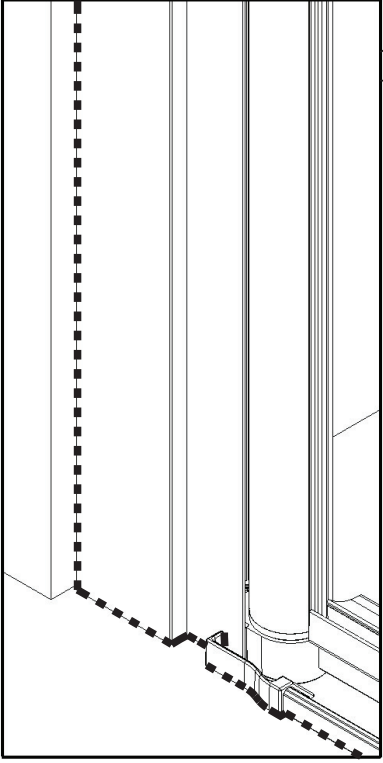
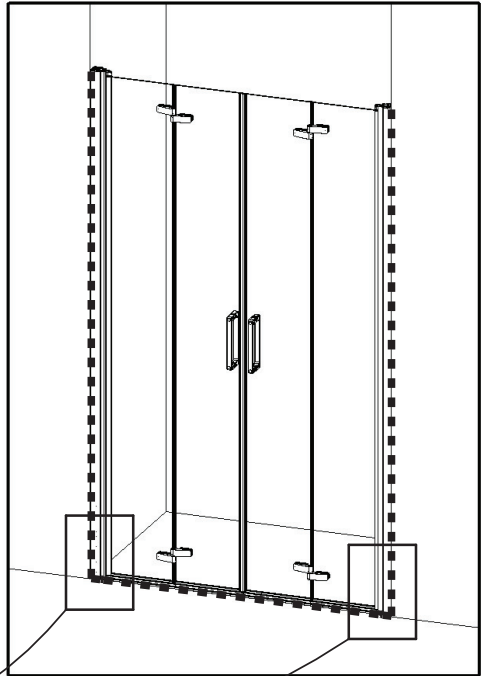









AQUAPRODUCTION, Site industriel,  
F - 44680 Chaumes-en-Retz

18

**EN 14428**

Paroi de douche, fabriquée en verre de silicate  
sodo-calcique de sécurité trempé thermiquement

Aptitude au nettoyage : réussite

Résistance à l'impact/propriétés de fragmentation : réussite

Durabilité : réussite



## SERVICE APRÈS-VENTE AFTER-SALES SERVICE

### FRANCE

+33 (0)2 40 21 29 45

### UK

+44 (0)20 8842 0033

### IRELAND

+353 04697 33102

### DEUTSCHLAND

+49 (0) 6074 / 30928 0

### ITALIA

+39 (0382) 6181

### ÖSTEREICH

+43 1 710 60 70

### SUISSE/SCHWEIZ

+41 (0)32 631 04 74

### ESPAÑA

+34 93 544 60 76

### NEDERLAND

+31 475 487 100

### BELGIQUE/BELGIË

+31 475 487 100

### РОССИЯ

+7 495 258-29-51

### PORTUGAL

+351 219 112 785